

CMOS Switched-Capacitor Voltage Converter

Features

- Simple conversion of V_{DD} to $-V_{DD}$
- Cascade connection (two devices are connected, $V_{OUT} = -2 V_{DD}$)
- Boost pin for higher switching frequency
- Easy to use
 - Requires only two external capacitors
- No external diode required
- Typically with no load voltage conversion, 99.9% efficiency
- Typical power efficiency is 98%
- Wide operating voltage range: 3V to 12V

Applications

- RS-232 power supply
- On board negative supply for dynamic RAMS
- Supply voltage splitter, $V_O = \pm V_{DD}/2$
- Operation amplifier supply
- Data acquisition systems
- Positive voltage doubler

General Description

HT7660 is a monolithic CMOS switched-capacitor voltage converter. HT7660 is designed to complete a voltage conversion from positive to negative. The only required external components are two low cost electrolytic capacitors.

HT7660 includes a voltage regulator, an RC oscillator and four output power MOS switches.

The frequency of an RC oscillator can be lowered by adding an external capacitor between V_{DD} and the OSC pin, or an external clock can be connected to the OSC pin to replace the original oscillator. The LV terminal may be tied to VSS to disable the voltage regulator. By doing this, low voltage operation can be improved.

Block Diagram

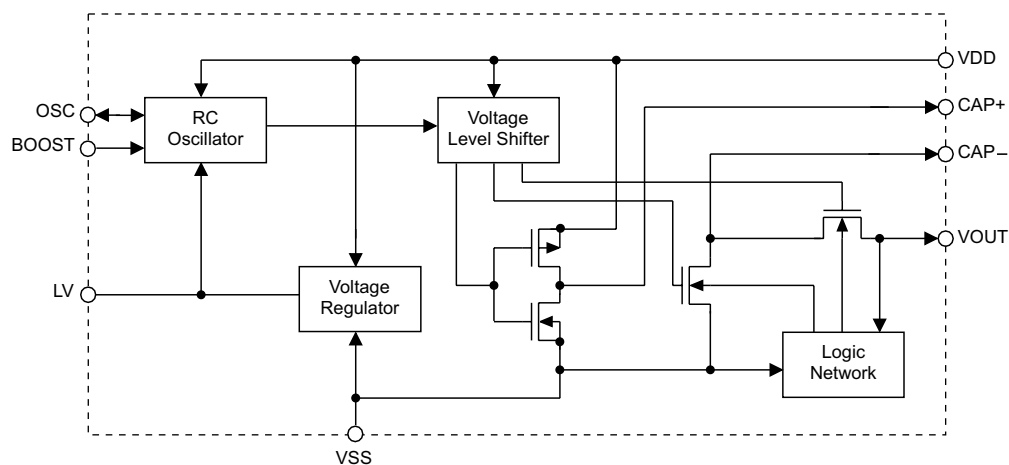

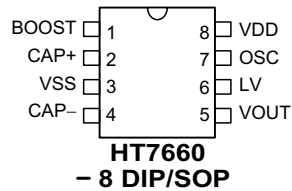
Pin Assignment

Pin Description

Pin No.	Pin Name	I/O	Internal Connection	Description
1	BOOST	I	CMOS Pull-low	Higher switching frequency selection input
2	CAP+	O	CMOS	This pin is connected to the positive terminal of Capacitor C1 for a charge pump
3	VSS	—	—	Negative power supply, ground
4	CAP-	O	NMOS	This pin is connected to the negative terminal of Capacitor C1 for a charge pump
5	VOUT	O	NMOS	This pin is connected to the negative terminal of Capacitor C2 for charge reservoir. Output voltage pass through this pin
6	LV	I	—	Floating this pin enables the voltage regulator. Connect this pin to VSS (Ground) to bypass voltage regulator and improve low voltage operation
7	OSC	I/O	Transmission Gate	External clock input pin. This pin can be connected with an external capacitor to reduce switching frequency
8	VDD	—	—	Positive power supply

Absolute Maximum Ratings

Supply Voltage-0.3V to 13V Operating Temperature-40°C to 85°C
 Storage Temperature.....-50°C to 125°C

Note: These are stress ratings only. Stresses exceeding the range specified under "Absolute Maximum Ratings" may cause substantial damage to the device. Functional operation of this device at other conditions beyond those listed in the specification is not implied and prolonged exposure to extreme conditions may affect device reliability.

Electrical Characteristics

Ta=25°C

Symbol	Parameter	Test Conditions		Min.	Typ.	Max.	Unit
		V _{DD}	Conditions				
V _{DD}	Operating Voltage	—	—	3	—	12	V
I _{STB}	Standby Current	3V	No load	—	26	100	μA
		5V		—	80	160	
f _{OSC}	System Frequency	3V	—	2.5	4	—	kHz
		5V		5	10	—	
R _{OUT}	Output Source Resistance	3V	I _{OUT} =10mA	—	97	150	Ω
		5V	I _{OUT} =20mA	—	60	100	
V _{CON-EFF}	Voltage Conversion Efficiency	3V	No load	99	—	—	%
		5V		99	99.9	—	
P _{EFF}	Power Efficiency	3V	R _L =5kΩ	96	—	—	%
		5V		96	98	—	

Functional Description

HT7660 needs only two external polarized electrolytic capacitors to complete a negative voltage converter.

HT7660 has four MOS power switches: S1, S2, S3 and S4. For the first half cycle, when S2 and S4 are open, Capacitor C1 is charged to a voltage V_{DD} through S1 and S3. During the second half cycle, when S1 and S3 are open, the charge on Capacitor C1 is shifted to Capacitor C2 through S2 and S4. Thereby, the voltage across Capacitor C2 is V_{DD} . Because the positive terminal of C2 is connected to V_{SS} , we get a $-V_{DD}$ voltage at V_{OUT} pin.

For high voltage operation, the LV pin is left floating to enable the voltage regulator. This can reduce the current consumption of the RC oscillator, and thus get a fixed switching frequency F_{osc} with high voltage range. For low voltage operation, the LV pin is connected to V_{SS} to bypass the voltage regulator of which inherent voltage drop can degrade the operation at low voltages.

A capacitor may be connected between V_{DD} and pin OSC to lower the switching F_{osc} , and an external clock may be added to replace the built-in RC oscillator.

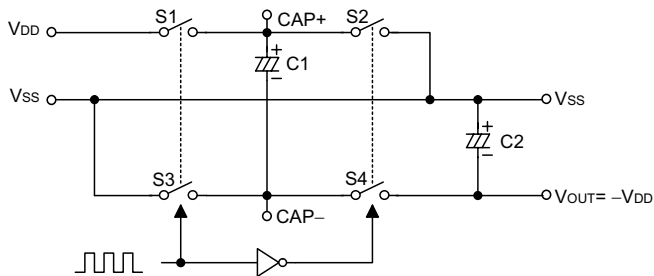

The operating mode of HT7660

Application Circuits

Simple negative voltage converter

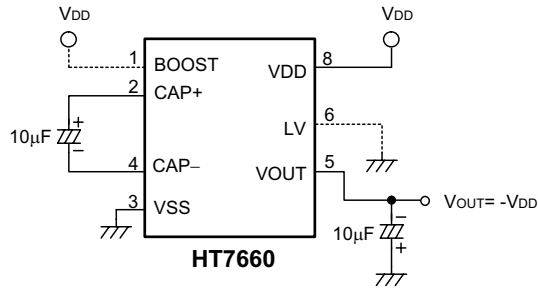

Simple voltage multiplier

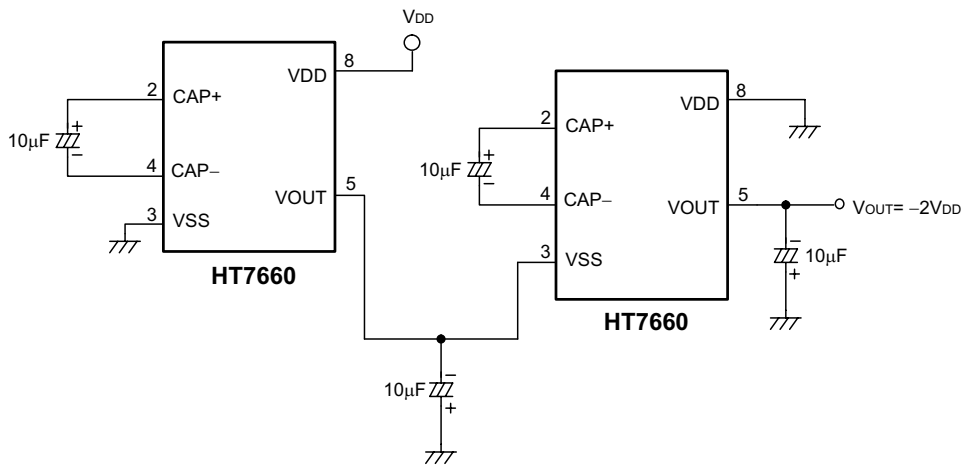

External switching frequency

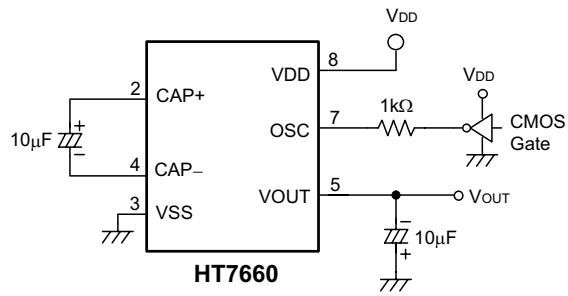

Lower switching frequency

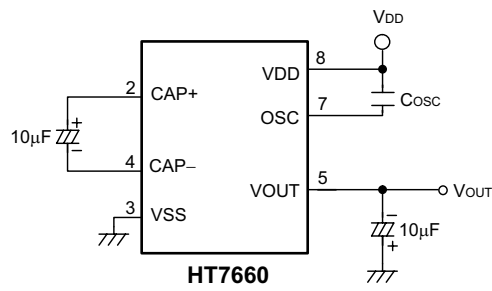

Note: C_{osc} is tens of pico farad

Positive voltage doubler

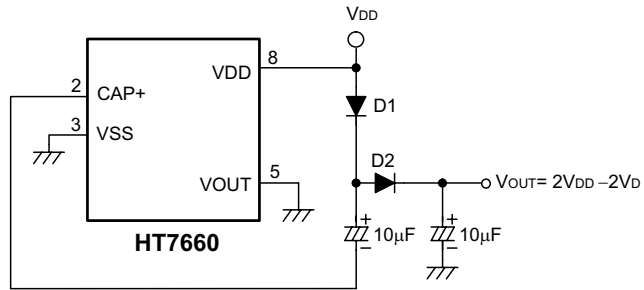

Note: V_d is forward voltage drop of diode D1 and D2

Voltage splitter

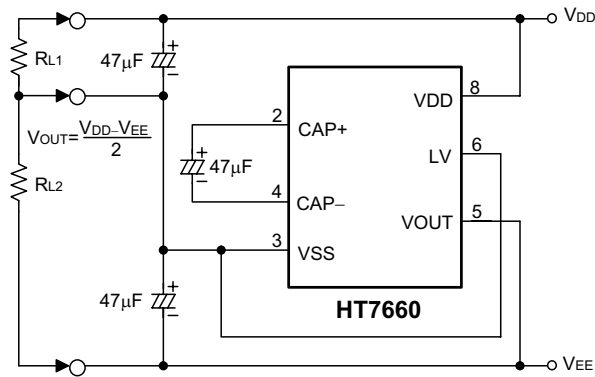

Combined negative voltage converter and positive voltage doubler

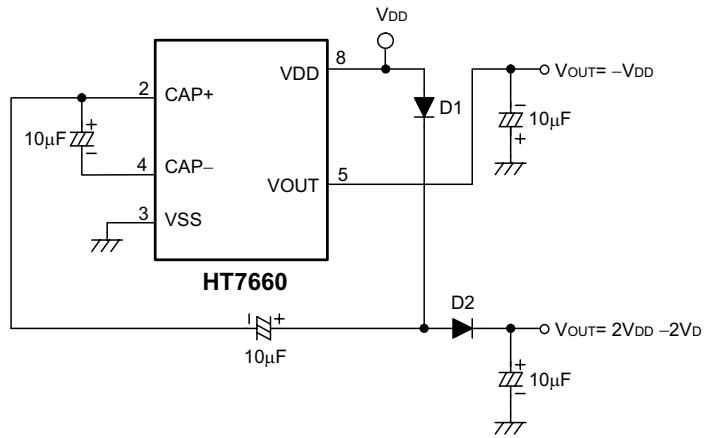

Note: V_D is forward voltage drop of diode D1 and D2

Holtek Semiconductor Inc. (Headquarters)

No.3 Creation Rd. II, Science-based Industrial Park, Hsinchu, Taiwan, R.O.C.
Tel: 886-3-563-1999
Fax: 886-3-563-1189

Holtek Semiconductor Inc. (Taipei Office)

5F, No.576, Sec.7 Chung Hsiao E. Rd., Taipei, Taiwan, R.O.C.
Tel: 886-2-2782-9635
Fax: 886-2-2782-9636
Fax: 886-2-2782-7128 (International sales hotline)

Holtek Semiconductor (Hong Kong) Ltd.

RM.711, Tower 2, Cheung Sha Wan Plaza, 833 Cheung Sha Wan Rd., Kowloon, Hong Kong
Tel: 852-2-745-8288
Fax: 852-2-742-8657

Copyright © 1999 by HOLTEK SEMICONDUCTOR INC.

The information appearing in this Data Sheet is believed to be accurate at the time of publication. However, Holtek assumes no responsibility arising from the use of the specifications described. The applications mentioned herein are used solely for the purpose of illustration and Holtek makes no warranty or representation that such applications will be suitable without further modification, nor recommends the use of its products for application that may present a risk to human life due to malfunction or otherwise. Holtek reserves the right to alter its products without prior notification. For the most up-to-date information, please visit our web site at <http://www.holtek.com.tw>.