

## GaAs MMIC LOW NOISE AMPLIFIER 15 - 24 GHz

FEBRUARY 2001

v01.05.00

### Features

EXCELLENT NOISE FIGURE : 2 dB

STABLE GAIN VS TEMPERATURE: 25 dB  $\pm$ 1.5 dB

SINGLE SUPPLY : +3V @ 36mA

SMALL SIZE: 1.32 mm x 2.08 mm

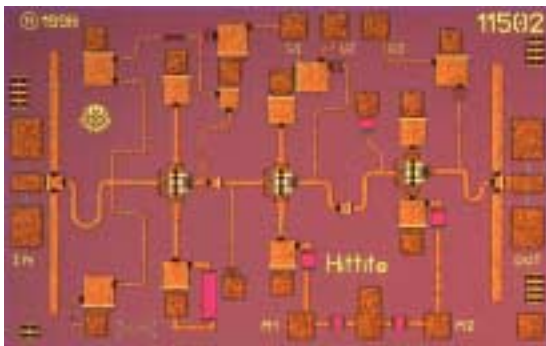

### General Description

The HMC262 chip is a GaAs MMIC Low Noise Amplifier (LNA) which covers the frequency range of 15 to 24 GHz. The chip can easily be integrated into Multi-Chip Modules (MCMs) due to its small (2.75 mm<sup>2</sup>) size. The chip utilizes a GaAs PHEMT process offering 25 dB gain from a single bias supply of + 3V @ 36 mA with a noise figure of 2 dB. This LNA can be used in microwave & millimeter wave point-to-point radios, VSAT, and other SATCOM applications. All data is with the chip in a 50 ohm test fixture connected via 0.025 mm (1 mil) diameter wire bonds of minimal length 0.31 mm (<12 mils). The HMC262 may be used in conjunction with HMC203, HMC258, HMC264, or HMC265 mixers to realize a microwave or millimeterwave system receiver.

### Guaranteed Performance, Vdd = +3V, -55 to +85 deg C

Parameter	Min.	Typ.	Max.	Min.	Typ.	Max.	Min.	Typ.	Max.	Units
Frequency Range	15 - 17			17 - 20			20 - 24			GHz
Gain	19	24		19	25		15	20		dB
Noise Figure		2.8	5.0		2.0	3.7		2.2	3.9	dB
Input Return Loss		5		4	10		6	12		dB
Output Return Loss	7	16		5	12			6		dB
Reverse Isolation	39	45		37	42		35	40		dB
Output Power for 1dB Compression (P1dB)	-1	3		1	4.5		0	4		dBm
Saturated Output Power (Psat)	3	8		4	8		2	6		dBm
Output Third Order Intercept (IP3)	8	13		9	13		6	10		dBm
Supply Voltage (Vdd)	2.75	3.0	3.25	2.75	3.0	3.25	2.75	3.0	3.25	Vdc
Supply Current (Idd) (Vdd= +3V)		36	48		36	48		36	48	mA



## HMC262 LOW NOISE AMPLIFIER 15 - 24 GHz

v01.05.00

FEBRUARY 2001

**Broadband Gain and Return Loss**

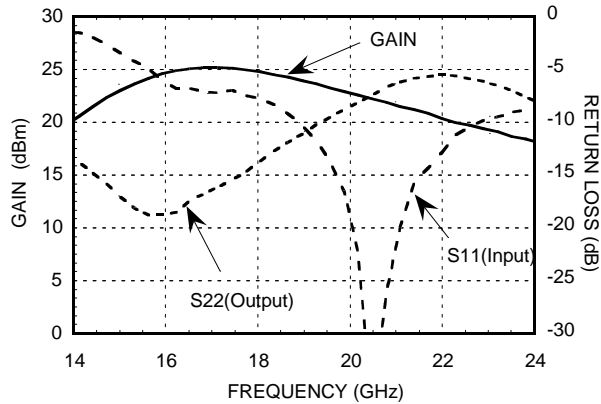

**Gain vs. Temperature**

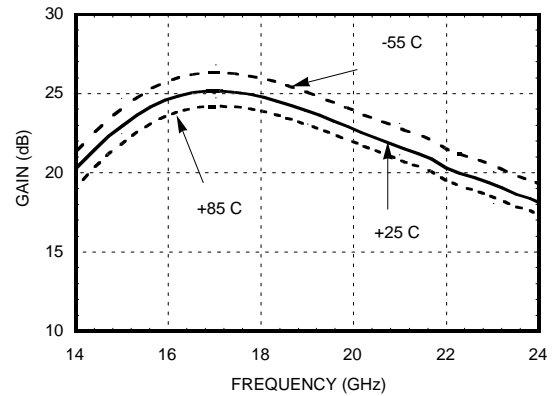

**Noise Figure**

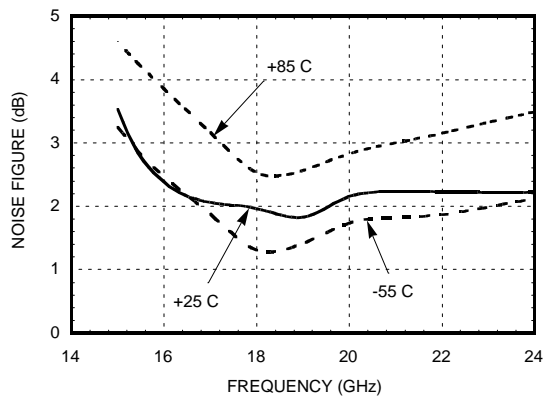

**Input Return Loss**

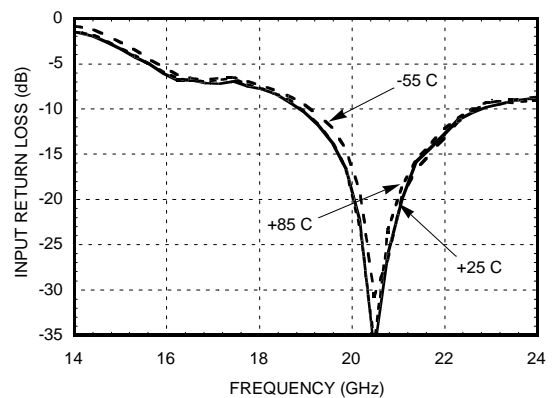

**Output Return Loss**

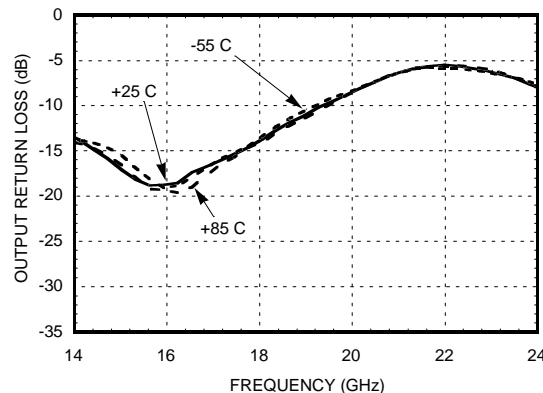

All data is with the chip in a 50 ohm test fixture connected via 0.025 mm (1 mil) diameter wire bonds of minimal length 0.31 mm (<12 mils).

## HMC262 LOW NOISE AMPLIFIER 15 - 24 GHz

FEBRUARY 2001

v01.05.00

1  
AMPLIFIERS  
DIE

### Isolation

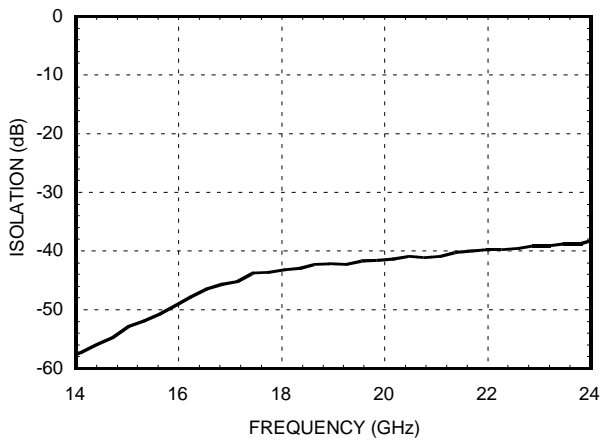

### IP3 Output @ Vdd = +3V

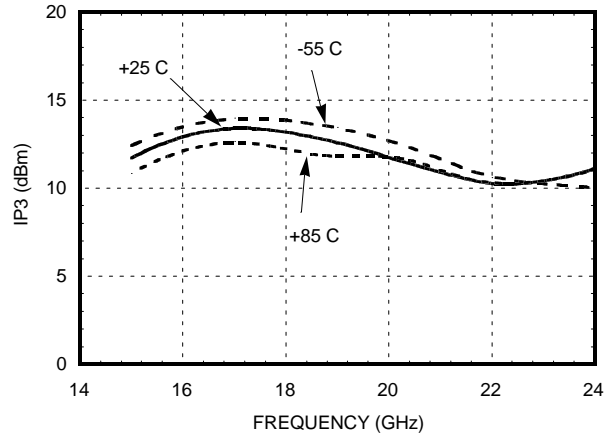

### P1dB Output @ Vdd = +3V

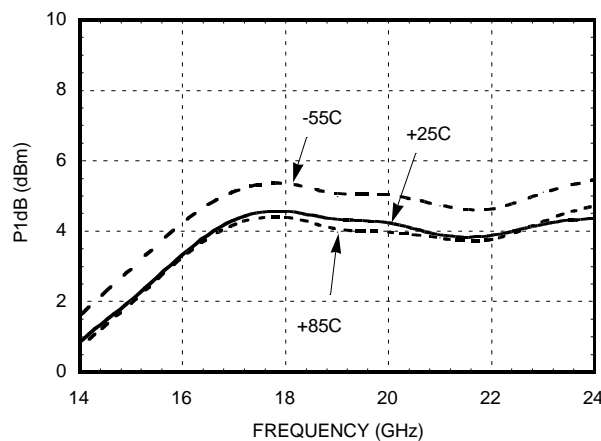

All data is with the chip in a 50 ohm test fixture connected via 0.025 mm (1 mil) diameter wire bonds of minimal length 0.31 mm (<12 mils).

## HMC262 LOW NOISE AMPLIFIER 15 - 24 GHz

v01.05.00

FEBRUARY 2001

### Schematic

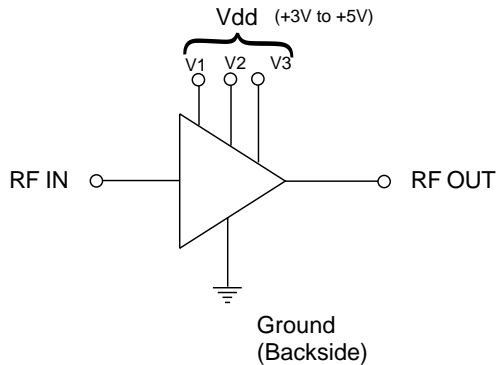

### Absolute Maximum Ratings

Supply Voltage (Vdd) (Vdd = V1 = V2 = V3)	+5.5 Vdc
Input Power (RFin) (Vdd = +3V)	-5 dBm
Channel Temperature (Tc)	175 °C
Thermal Resistance (Θjc) (Channel Backside)	90 °C/W
Storage Temperature	-65 to +150 °C
Operating Temperature	-55 to +85 °C

**NOTE:** Connect V1, V2, & V3 to Vdd via a 100pF single layer chip bypass capacitor. Place the capacitor no further than 0.762 mm (30mils) from the HMC262. M1 & M2 are to remain open circuit (no connection).

**Outline** ( See Die Handling, Mounting, Bonding Note Page 1 - 13 )

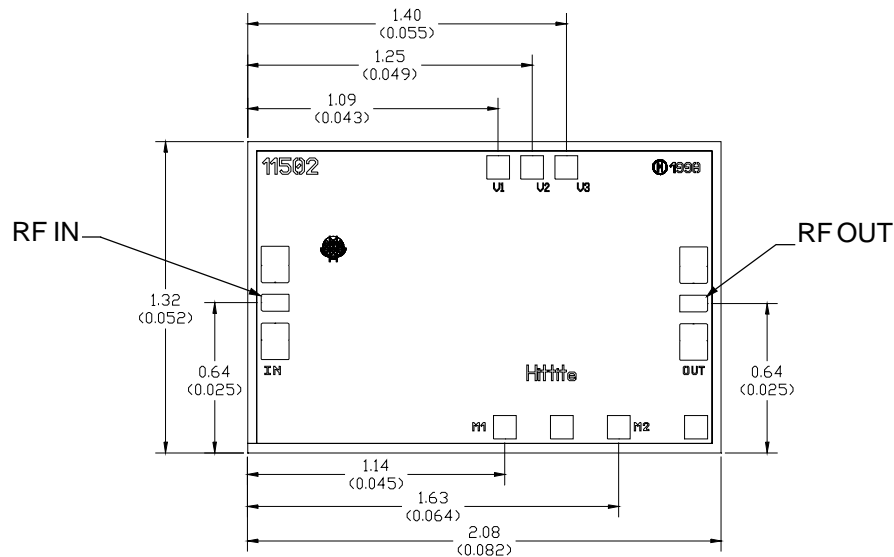

ALL DIMENSION IN MILLIMETERS (INCHES)  
 ALL TOLERANCES ARE ±0.025 (0.001)  
 DIE THICKNESS IS 0.100 (0.004) BACKSIDE IS GROUND  
 BOND PADS ARE 0.100 (0.004) SQUARE  
 BOND PAD SPACING, CTR-CTR: 0.150 (0.006)  
 BACKSIDE METALLIZATION: GOLD  
 BOND PAD METALLIZATION: GOLD

1  
AMPLIFIERS  
DIE

## HMC262 LOW NOISE AMPLIFIER 15 - 24 GHz

FEBRUARY 2001

v01.05.00

### MIC Assembly Techniques for HMC262

1

AMPLIFIERS

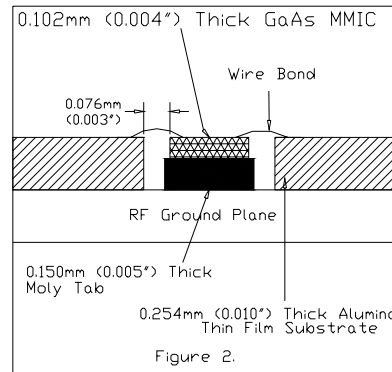
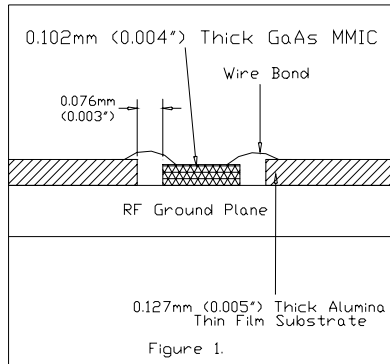

#### Mounting & Bonding Techniques for Millimeterwave GaAs MMICs

The die should be attached directly to the ground plane eutectically or with conductive epoxy (see HMC general Handling, Mounting, Bonding Note).

50 Ohm Microstrip transmission lines on 0.127mm (5 mil) thick alumina thin film substrates are recommended for bringing RF to and from the chip (Figure 1). If 0.254mm (10 mil) thick alumina thin film substrates must be used, the die should be raised 0.150mm (6 mils) so that the surface of the die is coplanar with the surface of the substrate. One way to accomplish this is to attach the 0.102mm (4 mil) thick die to a 0.150mm (6 mil) thick molybdenum heat spreader (moly-tab) which is then attached to the ground plane (Figure 2).

Microstrip substrates should be brought as close to the die as possible in order to minimize bond wire length. Typical die-to-substrate spacing is 0.076mm (3 mils).

An RF bypass capacitor should be used on the V<sub>dd</sub> input. A 100 pF single layer capacitor (mounted eutectically or by conductive epoxy) placed no further than 0.762mm (30 Mils) from the chip is recommended. The photo in figure 3 shows a typical assembly for the HMC262 MMIC chip.

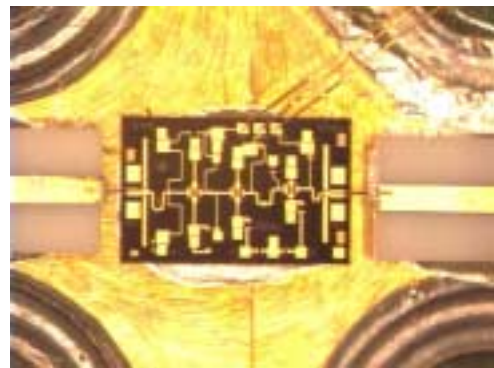

**Figure 3:** Typical HMC262 Assembly

## HMC262 LOW NOISE AMPLIFIER 15 - 24 GHz

v01.05.00

FEBRUARY 2001

### ***Handling Precautions***

Follow these precautions to avoid permanent damage.

**Cleanliness:** Handle the chips in a clean environment. DO NOT attempt to clean the chip using liquid cleaning systems.

**Static Sensitivity:** Follow ESD precautions to protect against ESD strikes ( see page 8 - 2 ).

**Transients:** Suppress instrument and bias supply transients while bias is applied. Use shielded signal and bias cables to minimize inductive pick-up.

**General Handling:** Handle the chip along the edges with a vacuum collet or with a sharp pair of bent tweezers. The surface of the chip has fragile air bridges and should not be touched with vacuum collet, tweezers, or fingers.

### ***Mounting***

The chip is back-metallized and can be die mounted with AuSn eutectic preforms or with electrically conductive epoxy. The mounting surface should be clean and flat.

#### **Eutectic Die Attach:**

A 80/20 gold tin preform is recommended with a work surface temperature of 255 deg. C and a tool temperature of 265 deg. C. When hot 90/10 nitrogen/hydrogen gas is applied, tool tip temperature should be 290 deg. C.

DO NOT expose the chip to a temperature greater than 320 deg. C for more than 20 seconds. No more than 3 seconds of scrubbing should be required for attachment.

#### **Epoxy Die Attach:**

Apply a minimum amount of epoxy to the mounting surface so that a thin epoxy fillet is observed around the perimeter of the chip once it is placed into position.

Cure epoxy per the manufacturer's schedule.

### ***Wire Bonding***

Ball or wedge bond with 0.025 mm (1 mil) diameter pure gold wire. Thermosonic wirebonding with a nominal stage temperature of 150 deg. C and a ball bonding force of 40 to 50 grams or wedge bonding force of 18 to 22 grams is recommended. Use the minimum level of ultrasonic energy to achieve reliable wirebonds.

Wirebonds should be started on the chip and terminated on the package or substrate. All bonds should be as short as possible <0.31 mm (12 mils).

1

AMPLIFIERS

DIE

