

HER301 - HER308

PRV : 50 - 1000 Volts
Io : 3.0 Amperes

FEATURES :

- * High current capability
- * High surge current capability
- * High reliability
- * Low reverse current
- * Low forward voltage drop
- * Fast switching for high efficiency
- * Pb / RoHS Free

MECHANICAL DATA :

- * Case : DO-201AD Molded plastic
- * Epoxy : UL94V-O rate flame retardant
- * Lead : Axial lead solderable per MIL-STD-202, Method 208 guaranteed
- * Polarity : Color band denotes cathode end
- * Mounting position : Any
- * Weight : 1.16 grams

HIGH EFFICIENT RECTIFIER DIODES

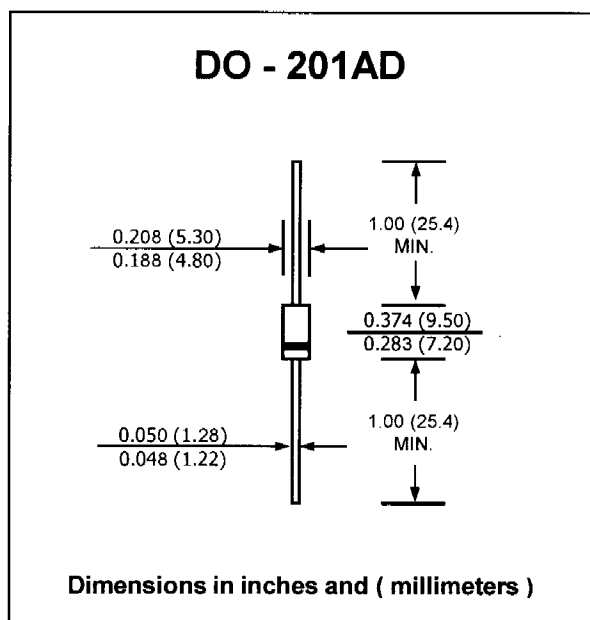

MAXIMUM RATINGS AND ELECTRICAL CHARACTERISTICS

Rating at 25 °C ambient temperature unless otherwise specified.
 Single phase, half wave, 60 Hz, resistive or inductive load.
 For capacitive load, derate current by 20%.

RATING	SYMBOL	HER 301	HER 302	HER 303	HER 304	HER 305	HER 306	HER 307	HER 308	UNIT
Maximum Recurrent Peak Reverse Voltage	V _{RRM}	50	100	200	300	400	600	800	1000	V
Maximum RMS Voltage	V _{RMS}	35	70	140	210	280	420	560	700	V
Maximum DC Blocking Voltage	V _{DC}	50	100	200	300	400	600	800	1000	V
Maximum Average Forward Current 0.375"(9.5mm) Lead Length Ta = 55 °C	I _{F(AV)}	3.0								A
Maximum Peak Forward Surge Current, 8.3ms Single half sine wave superimposed on rated load (JEDEC Method)	I _{FSM}	150								A
Maximum Forward Voltage at I _F = 3.0 A	V _F	1.1				1.7				V
Maximum DC Reverse Current Ta = 25 °C at Rated DC Blocking Voltage Ta = 100 °C	I _R	10								μA
	I _{R(H)}	50								μA
Maximum Reverse Recovery Time (Note 1)	T _{rr}	50				75				ns
Typical Junction Capacitance (Note 2)	C _J	50								pf
Junction Temperature Range	T _J	- 65 to + 150								°C
Storage Temperature Range	T _{STG}	- 65 to + 150								°C

Notes :

- (1) Reverse Recovery Test Conditions : I_F = 0.5 A, I_R = 1.0 A, I_{rr} = 0.25 A.
- (2) Measured at 1.0 MHz and applied reverse voltage of 4.0 V_{DC}

RATING AND CHARACTERISTIC CURVES (HER301 - HER308)

FIG.1 - REVERSE RECOVERY TIME CHARACTERISTIC AND TEST CIRCUIT DIAGRAM

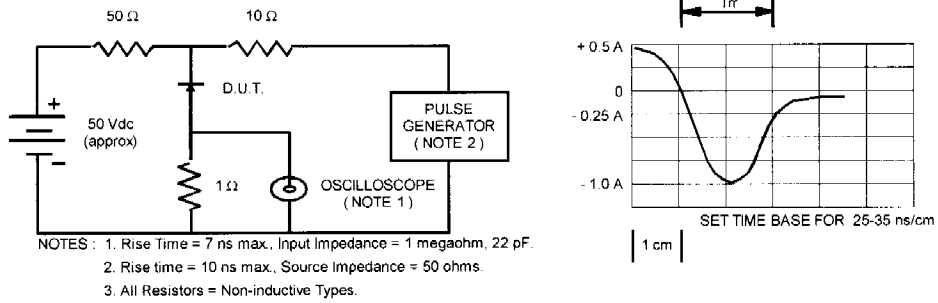

FIG.2 - DERATING CURVE FOR OUTPUT RECTIFIED CURRENT

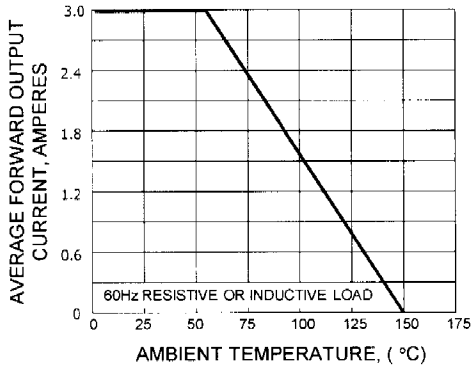

FIG.3 - MAXIMUM NON-REPETITIVE PEAK FORWARD SURGE CURRENT

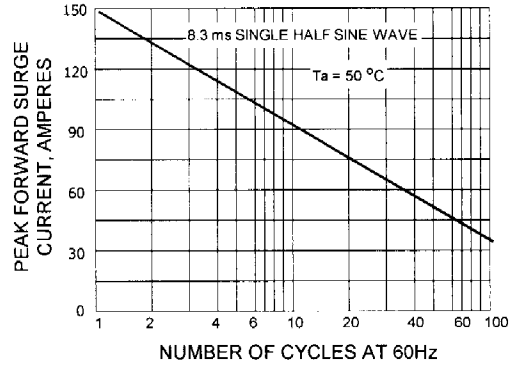

FIG.4 - TYPICAL FORWARD CHARACTERISTICS

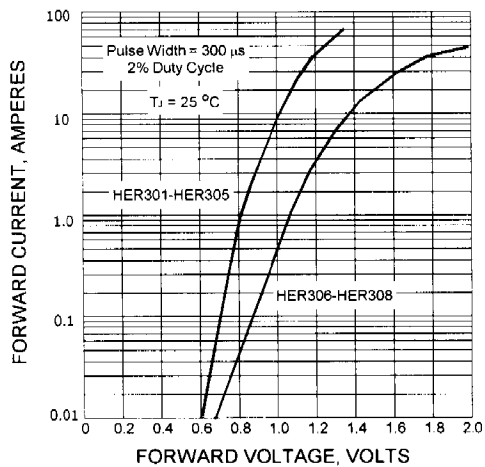

FIG.5 - TYPICAL REVERSE CHARACTERISTICS

