

---

# HD61830/HD61830B

LCDC (LCD Timing Controller)

# HITACHI

ADE-207-275(Z)  
'99.9  
Rev. 0.0

---

## Description

The HD61830/HD61830B is a dot matrix liquid crystal graphic display controller LSI that stores the display data sent from an 8-bit microcontroller in the external RAM to generate dot matrix liquid crystal driving signals.

It has a graphic mode in which 1-bit data in the external RAM corresponds to the on/off state of 1 dot on liquid crystal display and a character mode in which characters are displayed by storing character codes in the external RAM and developing them into the dot patterns with the internal character generator ROM. Both modes can be provided for various applications.

The HD61830/HD61830B is produced by the CMOS process. Thus, combined with a CMOS microcontroller it can complete a liquid crystal display device with lower power dissipation.

## Features

- Dot matrix liquid crystal graphic display controller
- Display control capacity
  - Graphic mode: 512k dots ( $2^{16}$  bytes)
  - Character mode: 4096 characters ( $2^{12}$  characters)
- Internal character generator ROM: 7360 bits
  - 160 types of  $5 \times 7$  dot characters
  - 32 types of  $5 \times 11$  dot characters
  - Total 192 characters
  - Can be extended to 256 characters (4 kbytes max.) with external ROM

---

## HD61830/HD61830B

---

- Interfaces to 8-bit MPU
- Display duty cycle (can be selected by a program)  
Static to 1/128 duty cycle
- Various instruction functions
  - Scroll, cursor on/off/blink, character blink, bit manipulation
- Display method: Selectable A or B types
- Internal oscillator (with external resistor and capacitor) HD61830
- Operating frequency
  - 1.1 MHz HD61830
  - 2.4 MHz HD61830B
- Low power dissipation
- Power supply: Single +5 V  $\pm 10\%$
- CMOS process

**Differences between Products  
HD61830 and HD61830B**

	<b>HD61830</b>	<b>HD61830B</b>
Oscillator	Internal or external	External only
Operating frequency	1.1 MHz	2.4 MHz
Pin arrangement and signal name	Pin 6: C Pin 7: R Pin 9: CPO	Pin 6: $\overline{CE}$ Pin 7: $\overline{OE}$ Pin 9: NC
Package marking to see figure	(A)	(B)

Package Marking

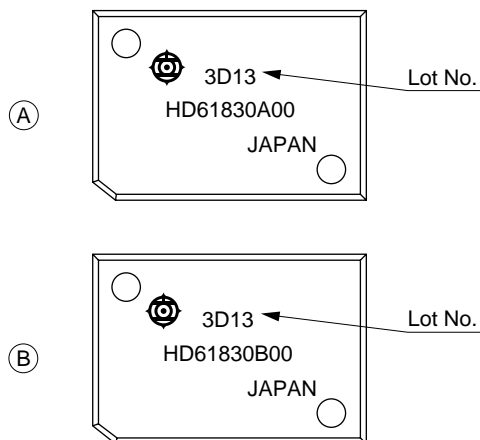

**Ordering Information**

Type No.	Package
HD61830A00H	60-pin plastic QFP (FP-60)
HD61830B00H	

Pin Arrangement

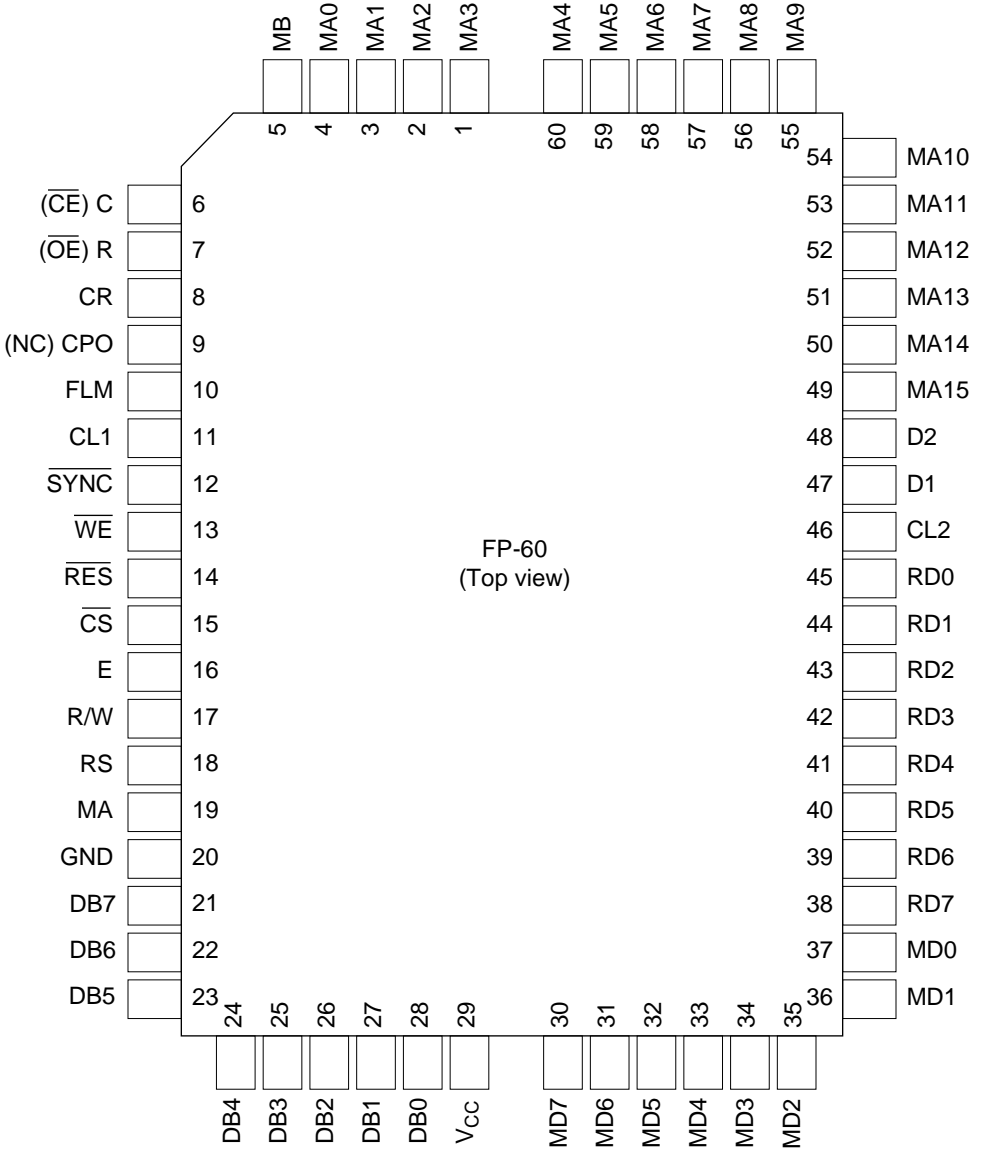

( ) is for HD61830B

**Terminal Functions**

<b>Symbol</b>	<b>Pin Number</b>	<b>I/O</b>	<b>Function</b>
DB0–DB7	28–21	I/O	Data bus: Three-state I/O common terminal Data is transferred to MPU through DB0 to DB7.
$\overline{CS}$	15	I	Chip select: Selected state with $\overline{CS} = 0$
R/W	17	I	Read/Write: R/W = 1: MPU ← HD61830 R/W = 0: MPU → HD61830
RS	18	I	Register select: RS = 1: Instruction register RS = 0: Data register
E	16	I	Enable: Data is written at the fall of E Data can be read while E is 1
CR	8	I	CR oscillator (HD61830), External clock input (HD61830B)
C	6	—	CR oscillator to capacitor (HD61830 only)
R	7	—	CR oscillator to resistor (HD61830 only)
CPO	9	O	Clock signal for HD61830 in slave mode (HD61830 only)
$\overline{CE}$	6	O	Chip enable (HD61830B only) $\overline{CE} = 0$ : Chip enables make external RAM in active
$\overline{OE}$	7	O	Output enable (HD61830B only) $\overline{OE} = 1$ : Output enable informs external RAM that HD61830B requires data bus
NC	9	Open	Unused terminal. Don't connect any wires to this terminal (HD61830B only)
MA0–MA15	4–1, 60–49	O	External RAM address output In character mode, the line code for external CG is output through MA12 to MA15 (0: Character 1st line, F: Character 16th line)
MD0–MD7	37–30	I/O	Display data bus: Three-state I/O common terminal
RD0–RD7	45–38	I	ROM data input: Dot data from external character generator is input
$\overline{WE}$	13	O	Write enable: Write signal for external RAM
CL2	46	O	Display data shift clock for LCD drivers
CL1	11	O	Display data latch signal for LCD drivers
FLM	10	O	Frame signal for display synchronization
MA	19	O	Signal for converting liquid crystal driving signal into AC, A type
MB	5	O	Signal for converting liquid crystal driving signal into AC, B type
D1	47	O	Display data serial output
D2	48		D1: For upper half of screen D2: For lower half of screen
$\overline{SYNC}$	12	I/O	Synchronous signal for parallel operation Three-state I/O common terminal (with pull-up MOS) Master: Synchronous signal is output Slave: Synchronous signal is input
$\overline{RES}$	14	I	Reset: Reset = 0 results in display off, slave mode and $H_p = 6$

Block Diagram

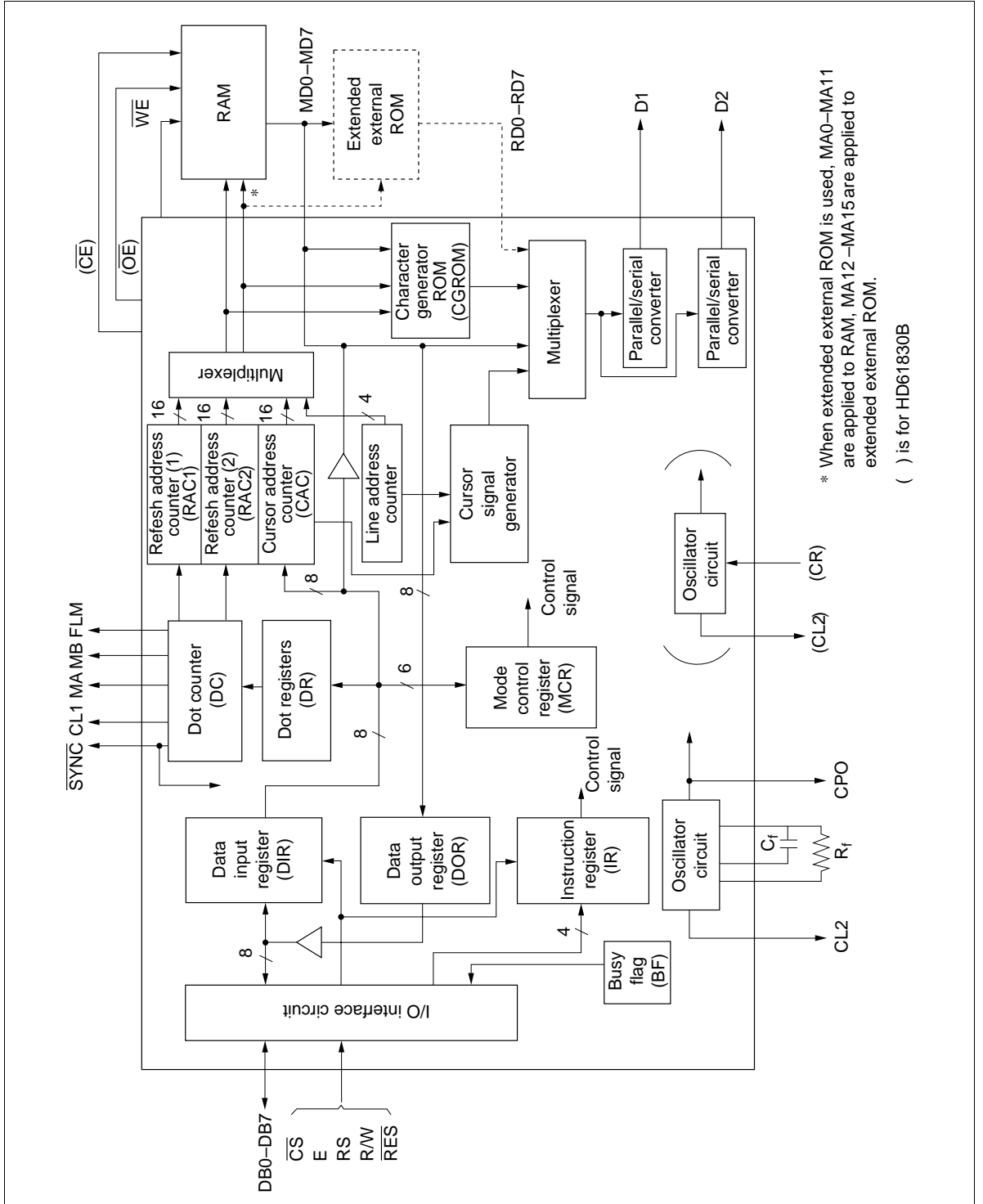

\* When extended external ROM is used, MA0-MA11 are applied to RAM, MA12-MA15 are applied to extended external ROM.

( ) is for HD61830B

## **Block Functions**

### **Registers**

The HD61830/HD61830B has the five types of registers: instruction register (IR), data input register (DIR), data output register (DOR), dot registers (DR), and mode control register (MCR).

The IR is a 4-bit register that stores the instruction codes for specifying MCR, DR, a start address register, a cursor address register, and so on. The lower order 4 bits DB0 to DB3 of data buses are written in it.

The DIR is an 8-bit register used to temporarily store the data written into the external RAM, DR, MCR, and so on.

The DOR is an 8-bit register used to temporarily store the data read from the external RAM. Cursor address information is written into the cursor address counter (CAC) through the DIR. When the memory read instruction is set in the IR (latched at the falling edge of E signal), the data of external RAM is read to DOR by an internal operation. The data is transferred to the MPU by reading the DOR with the next instruction (the contents of DOR are output to the data bus when E is at the high level).

The DR are registers used to store dot information such as character pitches and the number of vertical dots, and so on. The information sent from the MPU is written into the DR via the DIR.

The MCR is a 6-bit register used to store the data which specifies states of display such as display on/off and cursor on/off/blink. The information sent from the MPU is written in it via the DIR.

### **Busy Flag (BF)**

The busy flag = 1 indicates the HD61830 is performing an internal operation. Instructions cannot be accepted. As shown in Control Instruction, read busy flag, the busy flag is output on DB7 under the conditions of RS = 1, R/W = 1, and E = 1. Make sure the busy flag is 0 before writing the next instruction.

### **Dot Counters (DC)**

The dot counters are counters that generate liquid crystal display timing according to the contents of DR.

### **Refresh Address Counters (RAC1/RAC2)**

The refresh address counters, RAC1 and RAC2, control the addresses of external RAM, character generator ROM (CGROM), and extended external ROM. The RAC1 is used for the upper half of the screen and the RAC2 for the lower half. In the graphic mode, 16-bit data is output and used as the address signal of external RAM. In the character mode, the high order 4 bits (MA12–MA15) are ignored. The 4 bits of line address counter are output instead and used as the address of extended ROM.

### **Character Generator ROM**

The character generator ROM has 7360 bits in total and stores 192 types of character data. A character code (8 bits) from the external RAM and a line code (4 bits) from the line address counter are applied to its address signals, and it outputs 5-bit dot data.

The character font is  $5 \times 7$  (160 characters) or  $5 \times 11$  (32 characters). The use of extended ROM allows  $8 \times 16$  (256 characters max.) to be used.

### **Cursor Address Counter**

The cursor address counter is a 16-bit counter that can be preset by instruction. It holds an address when the data of external RAM is read or written (when display dot data or a character code is read or written). The value of the cursor address counter is automatically increased by 1 after the display data is read or written and after the set/clear bit instruction is executed.

### **Cursor Signal Generator**

The cursor can be displayed by instruction in character mode. The cursor is automatically generated on the display specified by the cursor address and cursor position.

### **Parallel/Serial Conversion**

The parallel data sent from the external RAM, character generator ROM, or extended ROM is converted into serial data by two parallel/serial conversion circuits and transferred to the liquid crystal driver circuits for upper screen and lower screen simultaneously.



**Display Control Instructions**

Display is controlled by writing data into the instruction register and 13 data registers. The RS signal distinguishes the instruction register from the data registers. 8-bit data is written into the instruction register with RS = 1, and the data register code is specified. After that, the 8-bit data is written in the data register and the specified instruction is executed with RS = 0.

During the execution of the instruction, no new instruction can be accepted. Since the busy flag is set during this, read the busy flag and make sure it is 0 before writing the next instruction.

**1. Mode Control:** (Execution time: 4  $\mu$ s) Code H'00 (hexadecimal) written into the instruction register specifies the mode control register.

Register	R/W	RS	DB7	DB6	DB5	DB4	DB3	DB2	DB1	DB0
Instruction reg.	0	1	0	0	0	0	0	0	0	0
Mode control reg.	0	0	0	0	Mode data					

DB5	DB4	DB3	DB2	DB1	DB0	Cursor/blink	CG	Graphic/character display
1/0	1/0	0	0	0	0	Cursor off	Internal CG	Character display (Character mode)
		0	1			Cursor on		
		1	0			Cursor off, character blink		
		1	1			Cursor blink		
		0	0	1	1	Cursor off	External CG	
		0	1			Cursor on		
		1	0			Cursor off, character blink		
		1	1			Cursor blink		
		0	0			1		
Display ON/OFF	Master/slave	Blink	Cursor	Graphic/character mode	Ext./Int. CG			

→ 1: Master mode  
0: Slave mode

→ 1: Display ON  
0: Display OFF

**2. Set Character Pitch:** (Execution time: 4  $\mu$ s)  $V_p$  indicates the number of vertical dots per character. The space between the vertically-displayed characters is included in the determination. This value is meaningful only during character display (in the character mode) and becomes invalid in the graphic mode.

$H_p$  indicates the number of horizontal dots per character in display, including the space between horizontally-displayed characters. In the graphic mode, the  $H_p$  indicates the number of bits of 1-byte display data to be displayed.

There are three  $H_p$  values (Table 1).

Register	R/W	RS	DB7	DB6	DB5	DB4	DB3	DB2	DB1	DB0
Instruction reg.	0	1	0	0	0	0	0	0	0	1
Character pitch reg.	0	0	$(V_p - 1)$ binary				0	$(H_p - 1)$ binary		

**Table 1**  $H_p$  Values

$H_p$	DB2	DB1	DB0	Horizontal Character Pitch
6	1	0	1	6
7	1	1	0	7
8	1	1	1	8

**3. Set Number of Characters:** (Execution time: 4  $\mu$ s)  $H_N$  indicates the number of horizontal characters in the character mode or the number of horizontal bytes in the graphic mode. If the total sum of horizontal dots on the screen is taken as n,

$$n = H_p \times H_N$$

$H_N$  can be set to an even number from 2 to 128 (decimal).

Register	R/W	RS	DB7	DB6	DB5	DB4	DB3	DB2	DB1	DB0
Instruction reg.	0	1	0	0	0	0	0	0	1	0
Number-of-characters reg.	0	0	0	(H <sub>N</sub> - 1) binary						

**4. Set Number of Time Divisions (Inverse of Display Duty Ratio):** (Execution time: 4  $\mu$ s)  $N_x$  indicates the number of time divisions in multiplex display.

$1/N_x$  is the display duty ratio.

A value of 1 to 128 (decimal) can be set to  $N_x$ .

Register	R/W	RS	DB7	DB6	DB5	DB4	DB3	DB2	DB1	DB0
Instruction reg.	0	1	0	0	0	0	0	0	1	1
Number-of-time-divisions reg.	0	0	0	(N <sub>x</sub> - 1) binary						

**5. Set Cursor Position:** (Execution time: 4  $\mu$ s)  $C_p$  indicates the position in a character where the cursor is displayed in the character mode. For example, in 5  $\times$  7 dot font, the cursor is displayed under a character by specifying  $C_p = 8$  (decimal). The cursor horizontal length is equal to the horizontal character pitch  $H_p$ . A value of 1 to 16 (decimal) can be set to  $C_p$ . If a smaller value than the vertical character pitch  $V_p$  is set ( $C_p \leq V_p$ ), and a character overlaps with the cursor, the cursor has higher priority of display (at cursor display on). If  $C_p$  is greater than  $V_p$ , no cursor is displayed. The cursor horizontal length is equal to  $H_p$ .

Register	R/W	RS	DB7	DB6	DB5	DB4	DB3	DB2	DB1	DB0
Instruction reg.	0	1	0	0	0	0	0	1	0	0
Cursor position reg.	0	0	0	0	0	0	(C <sub>p</sub> - 1) binary			

**6. Set Display Start Low Order Address:** (Execution time: 4  $\mu$ s) Cause display start addresses to be written in the display start address registers. The display start address indicates a RAM address at which the data displayed at the top left end on the screen is stored. In the graphic mode, the start address is composed of high/low order 16 bits. In the character display, it is composed of the lower 4 bits of high order address (DB3–DB0) and 8 bits of low order address. The upper 4 bits of high order address are ignored.

Register	R/W	RS	DB7	DB6	DB5	DB4	DB3	DB2	DB1	DB0
Instruction reg.	0	1	0	0	0	0	1	0	0	0
Display start address reg. (low order byte)	0	0	(Start low order address) binary							

### Set Display Start High Order Address

Register	R/W	RS	DB7	DB6	DB5	DB4	DB3	DB2	DB1	DB0
Instruction reg.	0	1	0	0	0	0	1	0	0	1
Display start address reg. (high order byte)	0	0	(Start high order address) binary							

**7. Set Cursor Address (Low Order) (RAM Write Low Order Address):** (Execution time: 4  $\mu$ s) Cause cursor addresses to be written in the cursor address counters. The cursor address indicates an address for sending or receiving display data and character codes to or from the RAM.

That is, data at the address specified by the cursor address are read/written. In the character mode, the cursor is displayed at the character specified by the cursor address.

A cursor address consists of the low-order address (8 bits) and the high-order address (8 bits). Satisfy the following requirements setting the cursor address (Table 2).

The cursor address counter is a 16-bit up-counter with set and reset functions. When bit N changes from 1 to 0, bit N + 1 is incremented by 1. When setting the low order address, the LSB (bit 1) of the high order address is incremented by 1 if the MSB (bit 8) of the low order address changes from 1 to 0. Therefore, set both the low order address and the high order address as shown in the Table 2.

Register	R/W	RS	DB7	DB6	DB5	DB4	DB3	DB2	DB1	DB0
Instruction reg.	0	1	0	0	0	0	1	0	1	0
Cursor address counter (low order byte)	0	0	(Cursor low order address) binary							

**Set Cursor Address (High Order) (RAM Write High Order Address)**

Register	R/W	RS	DB7	DB6	DB5	DB4	DB3	DB2	DB1	DB0
Instruction reg.	0	1	0	0	0	0	1	0	1	1
Cursor address counter (high order byte)	0	0	(Cursor high order address) binary							

**Table 2 Cursor Address Setting**

Condition	Requirement
When you want to rewrite (set ) both the low order address and the high order address.	Set the low order address and then set the high order address.
When you want to rewrite only the low order address.	Do not fail to set the high order address again after setting the low order address.
When you want to rewrite only the high order address.	Set the high order address. You do not have to set the low order address again.

**8. Write Display Data:** (Execution time: 6  $\mu$ s) After the code "\$0C" is written into the instruction register with RS = 1, 8-bit data with RS = 0 should be written into the data register. This data is transferred to the RAM specified by the cursor address as display data or character code. The cursor address is increased by 1 after this operation.

Register	R/W	RS	DB7	DB6	DB5	DB4	DB3	DB2	DB1	DB0
Instruction reg.	0	1	0	0	0	0	1	1	0	0
RAM	0	0	MSB (pattern data, character code) LSB							

**9. Read Display Data:** (Execution time: 6  $\mu$ s) Data can be read from the RAM with RS = 0 after writing code "\$0D" into the instruction register. Figure 1 shows the read procedure.

This instruction outputs the contents of data output register on the data bus (DB0 to DB7) and then transfers RAM data specified by the cursor address to the data output register, also increasing the cursor address by 1. After setting the cursor address, correct data is not output at the first read but at the second one. Thus, make one dummy read when reading data after setting the cursor address.

Register	R/W	RS	DB7	DB6	DB5	DB4	DB3	DB2	DB1	DB0
Instruction reg.	0	1	0	0	0	0	1	1	0	1
RAM	1	0	MSB (pattern data, character code) LSB							

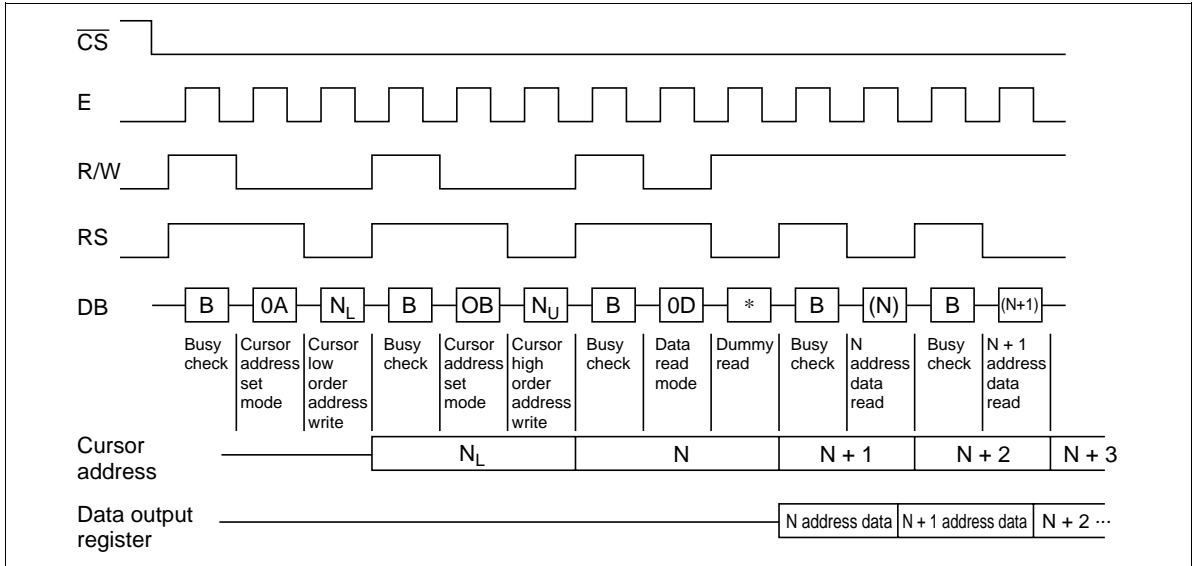

**Figure 1 Read Procedure**

**10. Clear Bit:** (Execution time: 36  $\mu$ s) The clear/set bit instruction sets 1 bit in a byte of display data RAM to 0 or 1, respectively. The position of the bit in a byte is specified by  $N_B$  and RAM address is specified by cursor address. After the execution of the instruction, the cursor address is automatically increased by 1.  $N_B$  is a value from 1 to 8.  $N_B = 1$  and  $N_B = 8$  indicates LSB and MSB, respectively.

Register	R/W	RS	DB7	DB6	DB5	DB4	DB3	DB2	DB1	DB0
Instruction reg.	0	1	0	0	0	0	1	1	1	0
Bit clear reg.	0	0	0	0	0	0	0	$(N_B - 1)$ binary		

**Set Bit**

Register	R/W	RS	DB7	DB6	DB5	DB4	DB3	DB2	DB1	DB0
Instruction reg.	0	1	0	0	0	0	1	1	1	1
Bit set reg.	0	0	0	0	0	0	0	$(N_B - 1)$ binary		

**11. Read Busy Flag:** (Execution time: 0  $\mu$ s) When the read mode is set with  $RS = 1$ , the busy flag is output to DB7. The busy flag is set to 1 during the execution of any of the other instructions. After the execution, it is set to 0. The next instruction can be accepted. No instruction can be accepted when busy flag = 1. Before executing an instruction or writing data, perform a busy flag check to make sure the busy flag is 0. When data is written in the register ( $RS = 1$ ), no busy flag changes. Thus, no busy flag check is required just after the write operation into the instruction register with  $RS = 1$ .

The busy flag can be read without specifying any instruction register.

Register	R/W	RS	DB7	DB6	DB5	DB4	DB3	DB2	DB1	DB0
Busy flag	1	1	1/0	*						

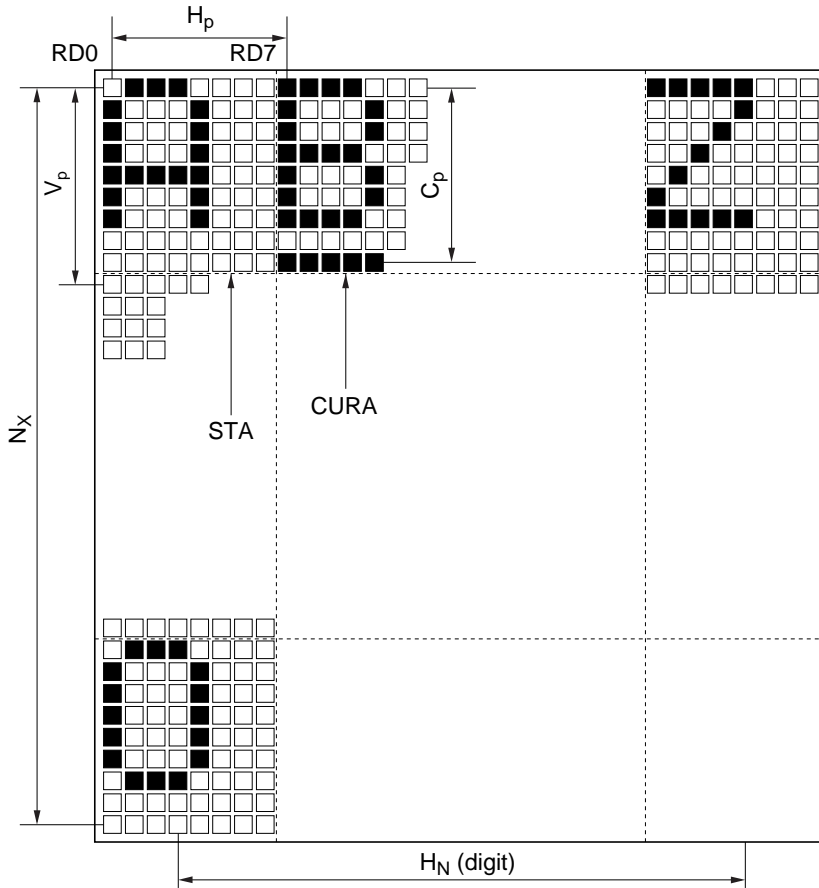

Symbol	Name	Meaning	Value
$H_p$	Horizontal character pitch	Horizontal character pitch	6 to 8 dots
$H_N$	Number of horizontal characters	Number of horizontal characters per line (number of digits) in the character mode or number of bytes per line in the graphic mode	2 to 128 digits (an even number)
$V_p$	Vertical character pitch	Vertical character pitch	1 to 16 dots
$C_p$	Cursor position	Line number on which the cursor can be displayed	1 to 16 lines
$N_x$	Number of time divisions	Inverse of display duty ratio	1 to 128 lines

Note: If the number of vertical dots on the screen is  $m$ , and the number of horizontal dots is  $n$ ,

$1/m = 1/N_x = \text{display duty ratio}$   
 $n = H_p \times H_N$   
 $m/V_p = \text{Number of display lines}$   
 $C_p \leq V_p$

Figure 2 Display Variables



Display Mode

Display Mode	Display Data from MPU	RAM	Liquid Crystal Display Panel
Character display	Character code (8 bits)	<p>RAM diagram for character display showing a 2x8 bit grid. The first row contains 01000001 and the second row contains 01000010. An arrow points to the start of the first row as the 'Start address'.</p>	<p>LCD panel diagram for character display showing a rectangular panel with three columns labeled A, B, and C. A horizontal arrow labeled <math>H_p</math> indicates the panel height.</p> <p><math>H_p</math>: 6, 7, or 8 dots</p>
Graphic	Display pattern (8 bits)	<p>RAM diagram for graphic display showing a 2x8 bit grid. The first row contains 01011111 and the second row contains 11111111. An arrow points to the start of the first row as the 'Start address'.</p>	<p>LCD panel diagram for graphic display showing a rectangular panel with a vertical bar of 8 dots. A horizontal arrow labeled <math>H_p</math> indicates the panel height. Two arrows labeled "8 dots" point to the vertical bar.</p> <p><math>H_p</math>: 8 dots</p>

Internal Character Generator Patterns and Character Codes

Higher 4 bits Lower 4 bits	0010	0011	0100	0101	0110	0111	1010	1011	1100	1101	1110	1111
xxxx0000		0	A	P	`	P		-	9	E	o	p
xxxx0001	!	1	A	Q	a	9	u	7	7	4	ä	q
xxxx0010	"	2	B	R	b	r	r	イ	ツ	×	ß	ø
xxxx0011	#	3	C	S	c	s	u	ウ	フ	エ	ε	ø
xxxx0100	\$	4	D	T	d	t	、	エ	ト	ト	μ	ø
xxxx0101	%	5	E	U	e	u	•	オ	ナ	ユ	ö	ü
xxxx0110	&	6	F	V	f	v	ヲ	カ	ニ	ヨ	ρ	Σ
xxxx0111	'	7	G	W	g	w	7	†	ヌ	ウ	g	π
xxxx1000	(	8	H	X	h	x	イ	ウ	ホ	リ	フ	×
xxxx1001	)	9	I	Y	i	y	ウ	ツ	ル	ル	‘	υ
xxxx1010	*	:	J	Z	j	z	エ	コ	ン	ク	j	†
xxxx1011	+	;	K	L	k	l	(	オ	サ	ヒ	×	π
xxxx1100	,	<	L	≠	l	l	ト	シ	フ	フ	φ	π
xxxx1101	-	=	M	I	m	n	)	ユ	ズ	、	ト	÷
xxxx1110	.	>	N	^	n	†	ヨ	ヒ	ホ	°	ñ	
xxxx1111	/	?	O	_	o	←	ツ	ユ	マ	°	ö	

Example of Correspondence between External CGROM Address Data and Character Pattern

8 × 8 Dot Font

		A10		0							0							0							1										
		A 9		0							0							1							0										
		A 8		0							0							1							1										
		A 7		0							1							0							1										
		A6	A5	A4	A3	A2	A1	A0	00	01	02	03	04	05	06	07	00	01	02	03	04	05	06	07											
0	0	0	0	0	0	0	0	1	1	1	1	0	0	0	0	0	0	1	1	1	1	0	0	0	0										
					0	0	1	1	0	0	0	1	0	0	0	1	0	0	0	1	0	0	0	1	0	0	0	0							
					0	1	0	1	0	0	0	1	0	0	0	1	0	0	0	1	0	0	0	1	0	0	0	0							
					0	1	1	1	1	1	1	0	0	0	0	0	0	0	0	1	0	0	0	1	0	0	0	0							
					1	0	0	1	0	1	0	0	0	0	0	0	0	0	0	1	0	1	0	1	0	0	0	0							
					1	0	1	1	0	0	1	0	0	0	0	0	0	0	0	1	0	0	1	0	0	0	0	0							
					1	1	0	1	0	0	0	1	0	0	0	0	0	0	0	1	1	0	1	0	0	0	0	0							
					1	1	1	0	0	0	0	0	0	0	0	0	0	0	0	0	0	0	0	0	0	0	0	0	0						
0	0	0	1	0	0	0	0	1	1	1	0	0	0	0	1	0	0	0	0	0	0	0	0	0	0										
					0	0	1	1	0	1	0	0	0	1	0	0	0	0	0	0	0	0	0	0	0	0	0								
					0	1	0	1	1	1	0	0	1	0	0	0	1	0	0	0	1	0	0	0	0	0	0	1							
					0	1	1	0	0	0	0	1	0	0	0	0	0	0	0	0	1	0	0	0	0	1	0								
					1	0	0	0	0	0	1	0	0	0	0	0	0	0	0	0	0	0	1	0	1	0	0								
					1	0	1	0	0	1	0	0	1	1	1	0	0	0	0	0	0	0	1	0	0	0	0								
					1	1	0	0	1	0	0	0	1	0	1	0	0	0	0	1	0	0	1	0	0	0	0								
					1	1	1	1	0	0	0	0	1	1	1	1	1	1	1	1	1	0	0	0	0	0	0								
0	0	1	0	0	0	0																													
				0	0	0																													

8 × 16 Dot Font

		A11		0							0							0																	
		A10		0							0							0																	
		A 9		0							0							1																	
		A 8		0							1							0																	
		A7	A6	A5	A4	A3	A2	A1	A0	00	01	02	03	04	05	06	07	00	01	02	03	04	05	06	07										
0	0	0	0	0	0	0	0	0	0	0	0	0	0	0	0	0	0	0	0	0	0	0	0	0	0										
				0	0	0	1	0	0	0	0	0	0	0	0	0	0	0	0	0	0	0	0	0	0	0	0	0							
				0	0	1	0	0	0	0	0	0	0	0	0	0	0	0	0	0	0	0	0	0	0	0	0	0							
				0	0	1	1	0	0	0	0	0	0	0	0	0	0	0	0	0	0	0	0	0	0	0	0	0							
				0	1	0	0	0	0	0	0	0	0	0	0	0	0	0	0	0	0	0	0	0	0	0	0	0							
				0	1	0	1	0	0	0	0	0	0	0	0	0	0	0	0	0	0	0	0	0	0	0	0	0							
				0	1	1	0	0	0	0	0	0	0	0	0	0	0	0	0	0	0	0	0	0	0	0	0	0							
				0	1	1	1	0	0	0	0	0	0	0	0	0	0	0	0	0	0	0	0	0	0	0	0	0							
				1	0	0	0	0	0	0	0	0	0	0	0	0	0	0	0	0	0	0	0	0	0	0	0	0							
				1	0	0	1	0	0	0	0	0	0	0	0	0	0	0	0	0	0	0	0	0	0	0	0	0							
				1	0	1	0	0	0	0	0	0	0	0	0	0	0	0	0	0	0	0	0	0	0	0	0	0							
				1	0	1	1	0	0	0	0	0	0	0	0	0	0	0	0	0	0	0	0	0	0	0	0	0							
				1	1	0	0	0	0	0	0	0	0	0	0	0	0	0	0	0	0	0	0	0	0	0	0	0							
				1	1	0	1	0	0	0	0	0	0	0	0	0	0	0	0	0	0	0	0	0	0	0	0	0							
				1	1	1	0	0	0	0	0	0	0	0	0	0	0	0	0	0	0	0	0	0	0	0	0	0							
				1	1	1	1	0	0	0	0	0	0	0	0	0	0	0	0	0	0	0	0	0	0	0	0	0							
0	0	0	0	0	0	0	0	0	0	0	0	0	0	0	0	0	0	0	0	0	0	0	0	0											

## Example of Configuration

### Graphic Mode or Character Mode (1) (Internal Character Generator)

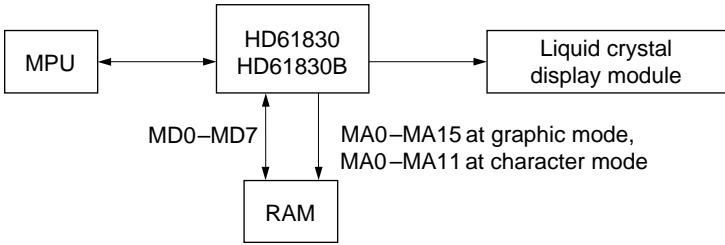

### Character Mode (2) (External Character Generator)

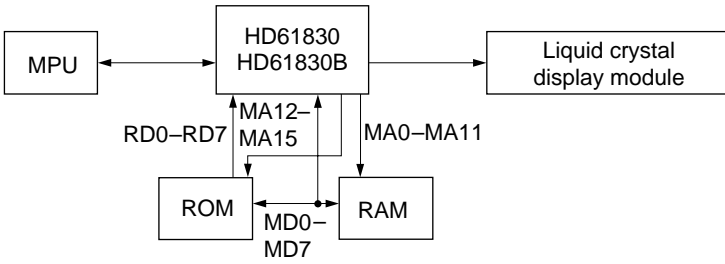

**Parallel Operation (HD61830)**

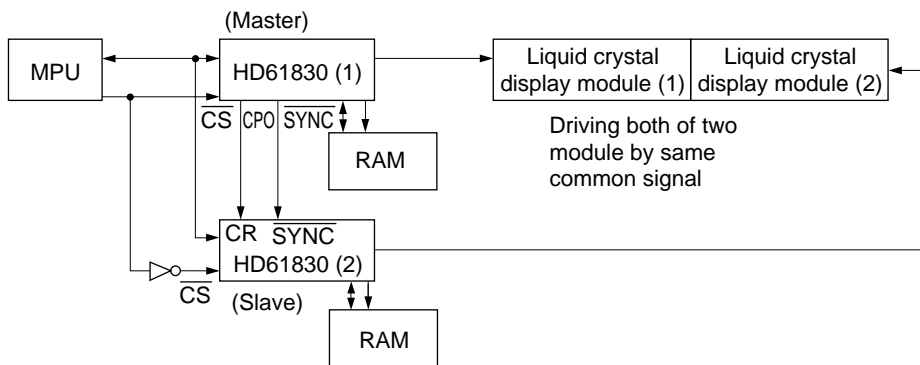

**Parallel Operation (HD61830B)**

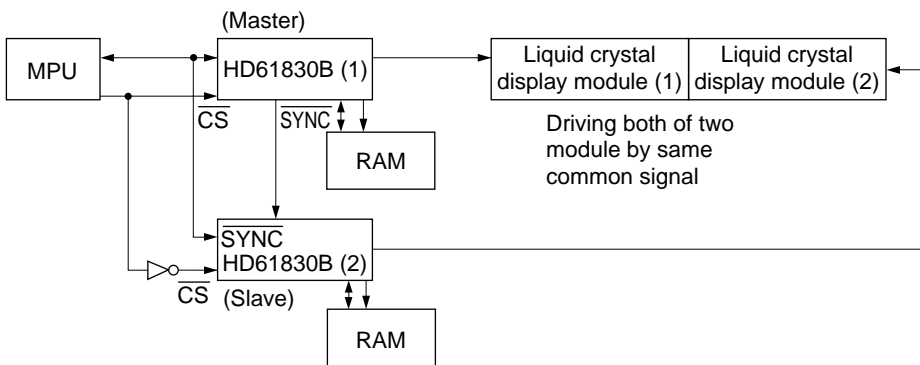

## HD61830 Application (Character Mode, External CG, Character Font 8 × 8)

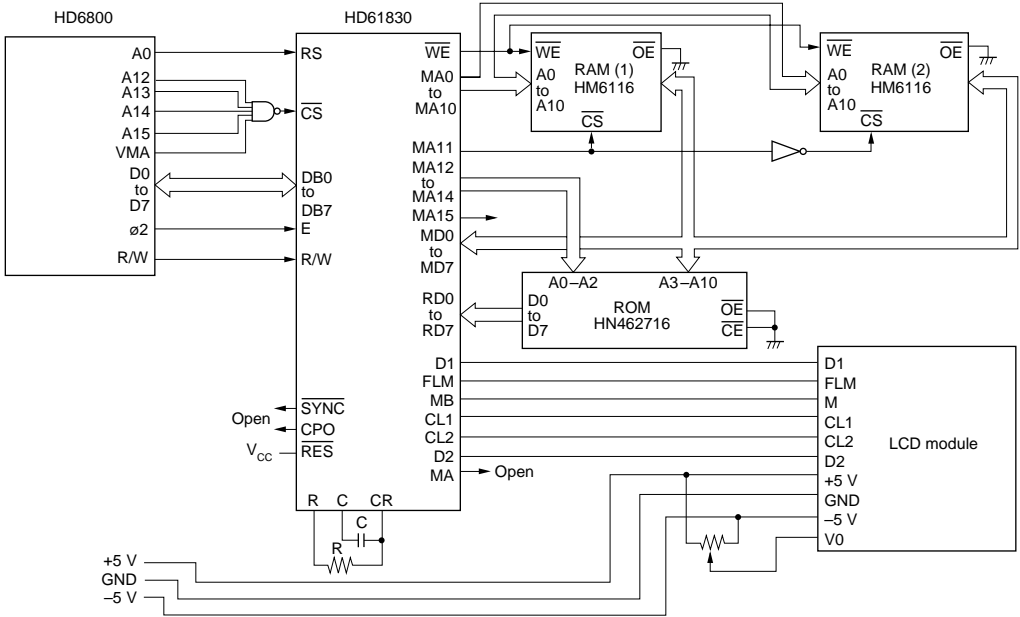

## HD61830 Application (Graphic Mode)

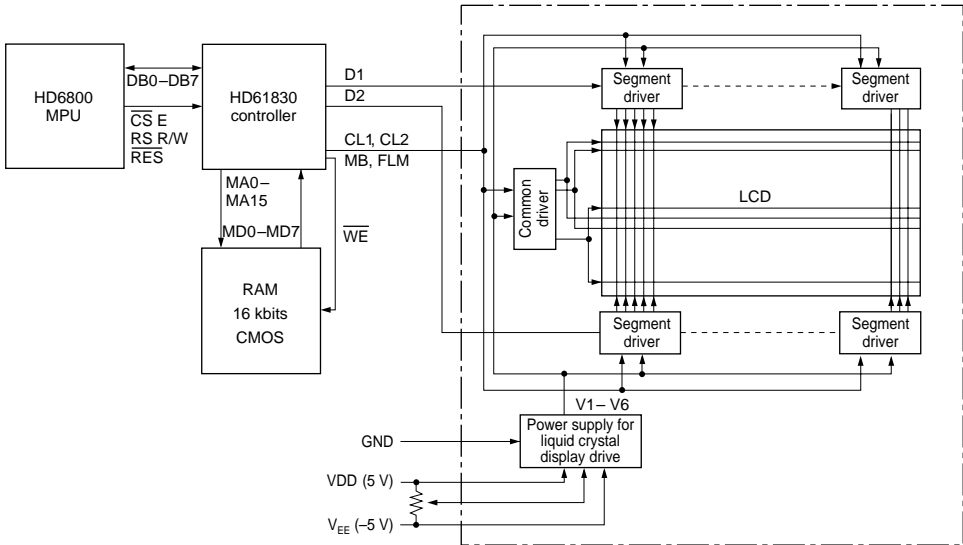

HD61830B Application (Character Mode, External CG, Character Font 8 × 8)

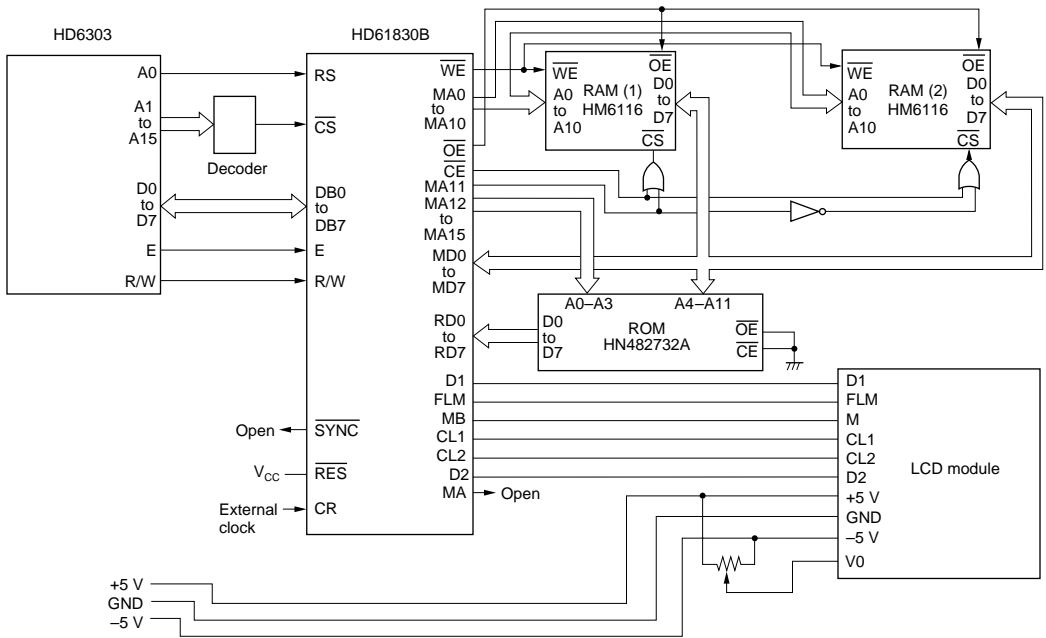

HD61830B Application (Graphic Mode)

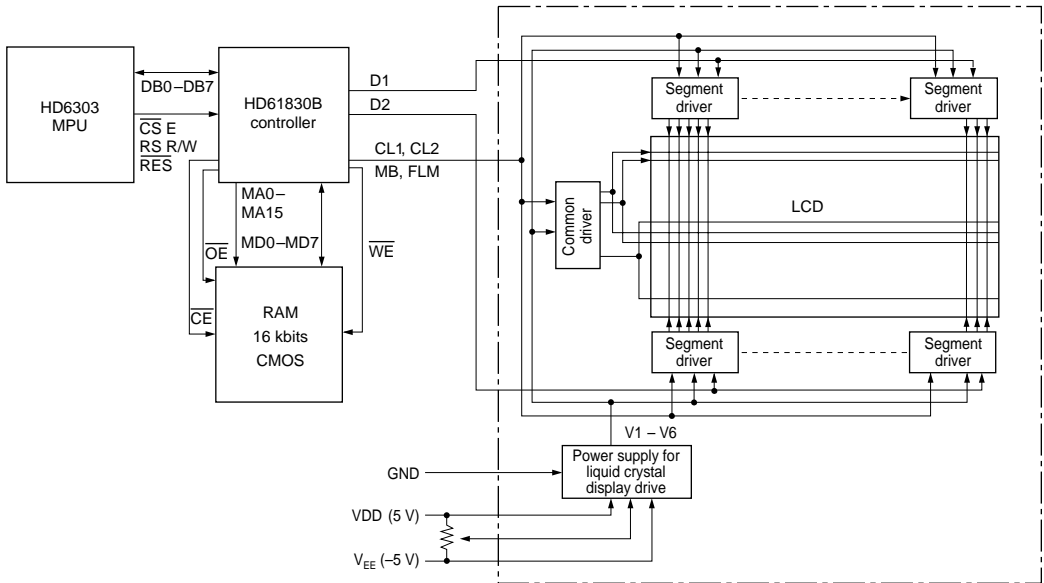

**HD61830 Absolute Maximum Ratings**

<b>Item</b>	<b>Symbol</b>	<b>Value</b>	<b>Unit</b>	<b>Notes</b>
Supply voltage	$V_{CC}$	-0.3 to +0.7	V	1, 2
Terminal voltage	VT	-0.3 to $V_{CC} + 0.3$	V	1, 2
Operating temperature	$T_{opr}$	-20 to +75	°C	
Storage temperature	$T_{stg}$	-55 to +125	°C	

Notes: 1. All voltages are referenced to GND = 0 V.

2. If LSIs are used beyond absolute maximum ratings, they may be permanently destroyed.

We strongly recommend that you use the LSIs within electrical characteristic limits for normal operation, because use beyond these conditions will cause malfunction and poor reliability.



**HD61830 Electrical Characteristics ( $V_{CC} = 5\text{ V} \pm 10\%$ ,  $GND = 0\text{ V}$ ,  $T_a = -20$  to  $+75^\circ\text{C}$ )**

Item	Symbol	Min	Typ	Max	Unit	Test Condition	Notes
Input high voltage (TTL)	$V_{IH}$	2.2	—	$V_{CC}$	V		1
Input low voltage (TTL)	$V_{IL}$	0	—	0.8	V		2
Input high voltage	$V_{IHR}$	3.0	—	$V_{CC}$	V		3
Input high voltage (CMOS)	$V_{IHC}$	$0.7 V_{CC}$	—	$V_{CC}$	V		4
Input low voltage (CMOS)	$V_{ILC}$	0	—	$0.3 V_{CC}$	V		4
Output high voltage (TTL)	$V_{OH}$	2.4	—	$V_{CC}$	V	$-I_{OH} = 0.6\text{ mA}$	5
Output low voltage (TTL)	$V_{OL}$	0	—	0.4	V	$I_{OL} = 1.6\text{ mA}$	5
Output high voltage (CMOS)	$V_{OHC}$	$V_{CC} - 0.4$	—	$V_{CC}$	V	$-I_{OH} = 0.6\text{ mA}$	6
Output low voltage (CMOS)	$V_{OLC}$	0	—	0.4	V	$I_{OL} = 0.6\text{ mA}$	6
Input leakage current	$I_{IN}$	-5	—	5	$\mu\text{A}$	$V_{IN} = 0 - V_{CC}$	7
Three-state leakage current	$I_{TSL}$	-10	—	10	$\mu\text{A}$	$V_{OUT} = 0 - V_{CC}$	8
Power dissipation (1)	$P_{W1}$	—	10	15	mW	CR oscillation $f_{osc} = 500\text{ kHz}$	9
Power dissipation (2)	$P_{W2}$	—	20	30	mW	External clock $f_{cp} = 1\text{ MHz}$	9
Internal clock operation (Clock oscillation frequency)	$f_{osc}$	400	500	600	kHz	$C_f = 15\text{ pF} \pm 5\%$ $R_f = 39\text{ k}\Omega \pm 2\%$	10
External clock operation (External clock operating frequency)	$f_{cp}$	100	500	1100	kHz		11
External clock duty	Duty	47.5	50	52.5	%		11
External clock rise time	$t_{rcp}$	—	—	0.05	$\mu\text{s}$		11
External clock fall time	$t_{fcp}$	—	—	0.05	$\mu\text{s}$		11
Pull-up current	$I_{PL}$	2	10	20	$\mu\text{A}$	$V_{IN} = GND$	12

Notes: The I/O terminals have the following configuration:

1. Applied to input terminals and I/O common terminals, except terminals  $\overline{\text{SYNC}}$ , CR, and  $\overline{\text{RES}}$ .
2. Applied to input terminals and I/O common terminals, except terminals  $\overline{\text{SYNC}}$  and CR.
3. Applied to terminal  $\overline{\text{RES}}$ .
4. Applied to terminals  $\overline{\text{SYNC}}$  and CR.
5. Applied to terminals DB0–DB7,  $\overline{\text{WE}}$ , MA0–MA15, and MD0–MD7.
6. Applied to terminals  $\overline{\text{SYNC}}$ , CP0, FLM, CL1, CL2, D1, D2, MA, and MB.
7. Applied to input terminals.
8. Applied to I/O common terminals. However, the current which flows into the output drive MOS is excluded.

9. The current which flows into the input and output circuits is excluded. When the input of CMOS is in the intermediate level, current flows through the input circuit, resulting in the increase of power supply current. To avoid this, input must be fixed at high or low.

The relationship between the operating frequency and the power dissipation is given below.

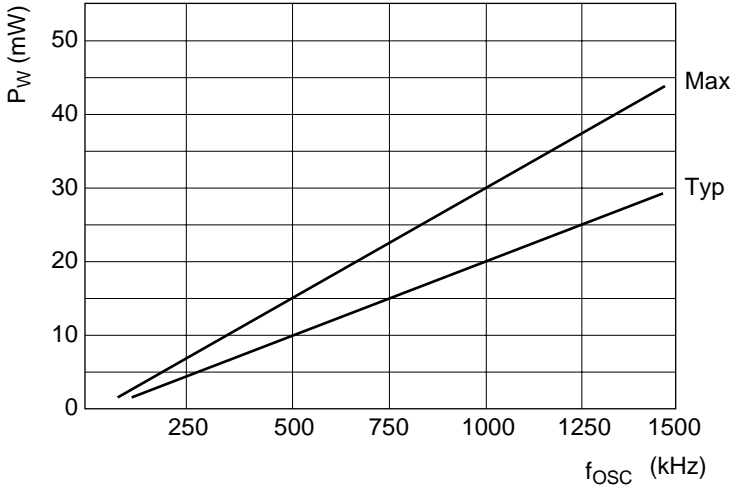

10. Applied to the operation of the internal oscillator when oscillation resistor  $R_f$  and oscillation capacity  $C_f$  are used.



The relationship among oscillation frequency,  $R_f$  and  $C_f$  is given below.

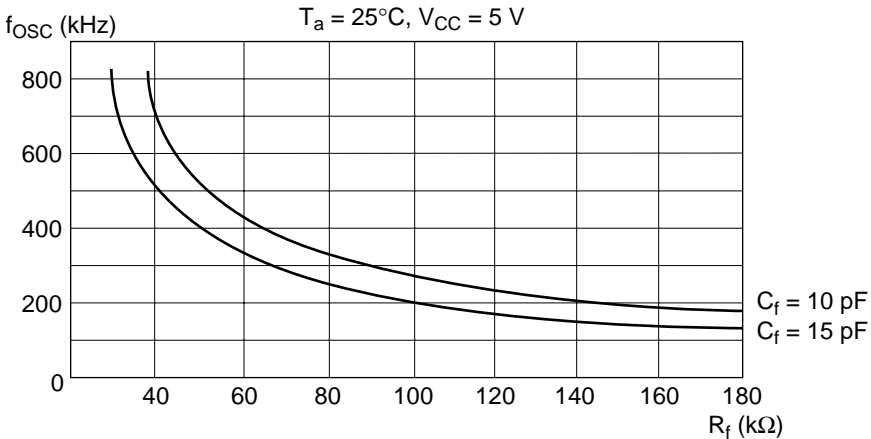

11. Applied to external clock operation.

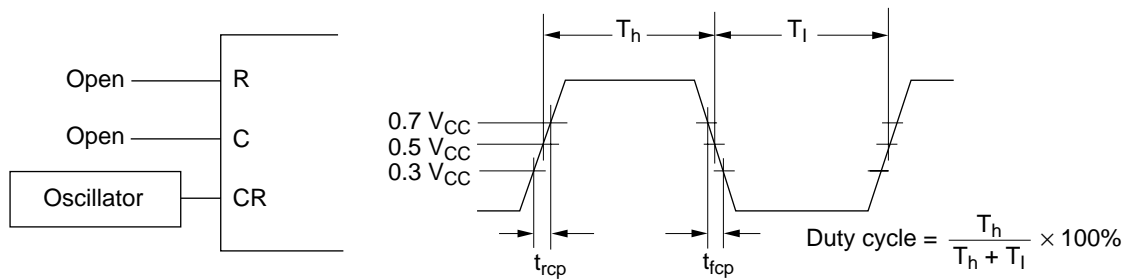

12. Applied to  $\overline{\text{SYNC}}$ , DB0–DB7, and RD0–RD7.

## Input Terminal

Applicable terminal:  $\overline{CS}$ , E, RS, R/W,  $\overline{RES}$ , CR (without pull-up MOS)

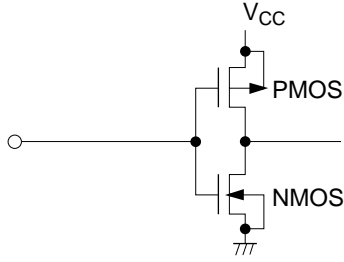

Applicable terminal: RD0–RD7 (with pull-up MOS)

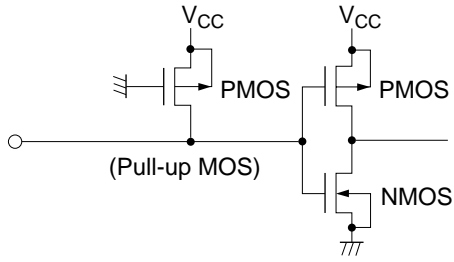

**Output Terminal**

Applicable terminal: CL1, CL2, MA, MB, FLM, D1, D2,  $\overline{WE}$ , CPO, MA0–MA15

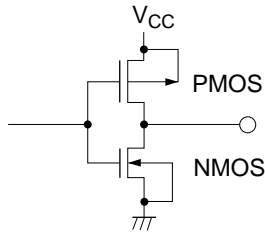

**I/O Common Terminal**

Applicable terminal: DB0–DB7,  $\overline{SYNC}$ , MD0–MD7 (MD0–MD7 have no pull-up MOS)

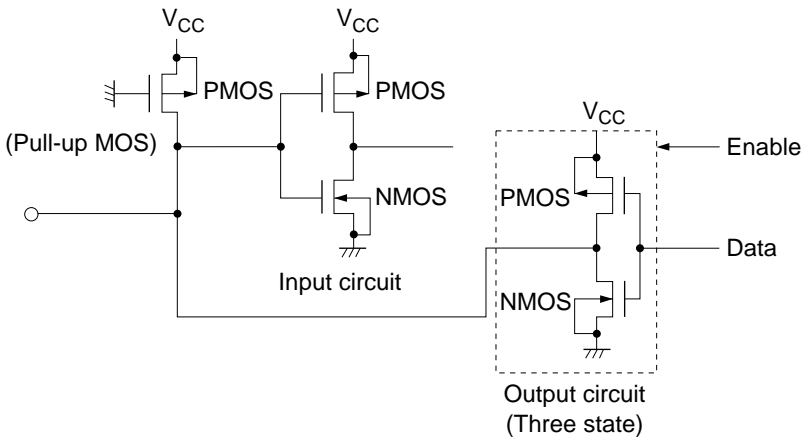

## Timing Characteristics

HD61830 MPU Interface ( $V_{CC} = 5\text{ V} \pm 10\%$ ,  $GND = 0\text{ V}$ ,  $T_a = -20\text{ to }+75^\circ\text{C}$ )

Item		Symbol	Min	Typ	Max	Unit
Enable cycle time		$t_{CYC}$	1.0	—	—	$\mu\text{s}$
Enable pulse width	High level	$t_{WEH}$	0.45	—	—	$\mu\text{s}$
	Low level	$t_{WEL}$	0.45	—	—	$\mu\text{s}$
Enable rise time		$t_{Er}$	—	—	25	ns
Enable fall time		$t_{Ef}$	—	—	25	ns
Setup time		$t_{AS}$	140	—	—	ns
Data setup time		$t_{DSW}$	225	—	—	ns
Data delay time		$t_{DDR}$	—	—	225	ns *
Data hold time		$t_{DHW}$	10	—	—	ns
Address hold time		$t_{AH}$	10	—	—	ns
Output data hold time		$t_{DH}$	20	—	—	ns

Note: \* The following load circuit is connected for specification:

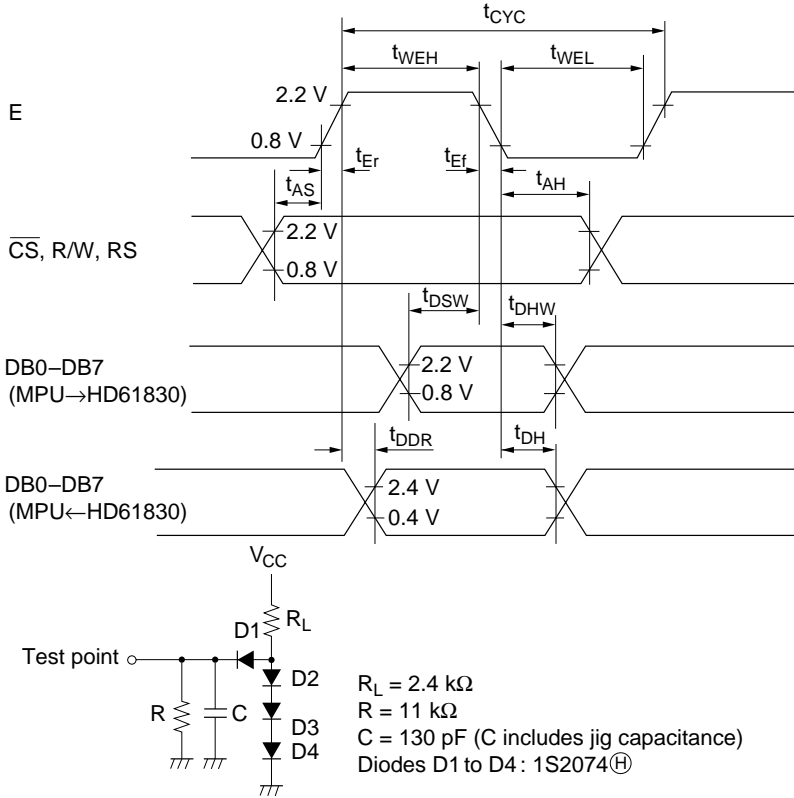

## HD61830 External RAM and ROM Interface ( $V_{CC} = 5\text{ V} \pm 10\%$ , $GND = 0\text{ V}$ , $T_a = -20\text{ to }+75^\circ\text{C}$ )

Item		Symbol	Min	Typ	Max	Unit
SYNC delay time		$t_{DSY}$	—	—	200	ns
SYNC pulse width	Low level	$t_{WSY}$	900	—	—	ns
CPO cycle time		$t_{CCPO}$	900	—	—	ns
CPO pulse width	High level	$t_{WCPOH}$	450	—	—	ns
	Low level	$t_{WCPOL}$	450	—	—	ns
MA0 to MA15 refresh delay time		$t_{DMAR}$	—	—	200	ns
MA0 to MA15 write address delay time		$t_{DMAW}$	—	—	200	ns
MD0 to MD7 write data delay time		$t_{DMDW}$	—	—	200	ns
MD0 to MD7, RD0 to RD7 setup time		$t_{SMD}$	900	—	—	ns
Memory address setup time		$t_{SMAW}$	250	—	—	ns
Memory data setup time		$t_{SMDW}$	250	—	—	ns
$\overline{WE}$ delay time		$t_{DWE}$	—	—	200	ns
$\overline{WE}$ pulse width (low level)		$t_{WWE}$	450	—	—	ns

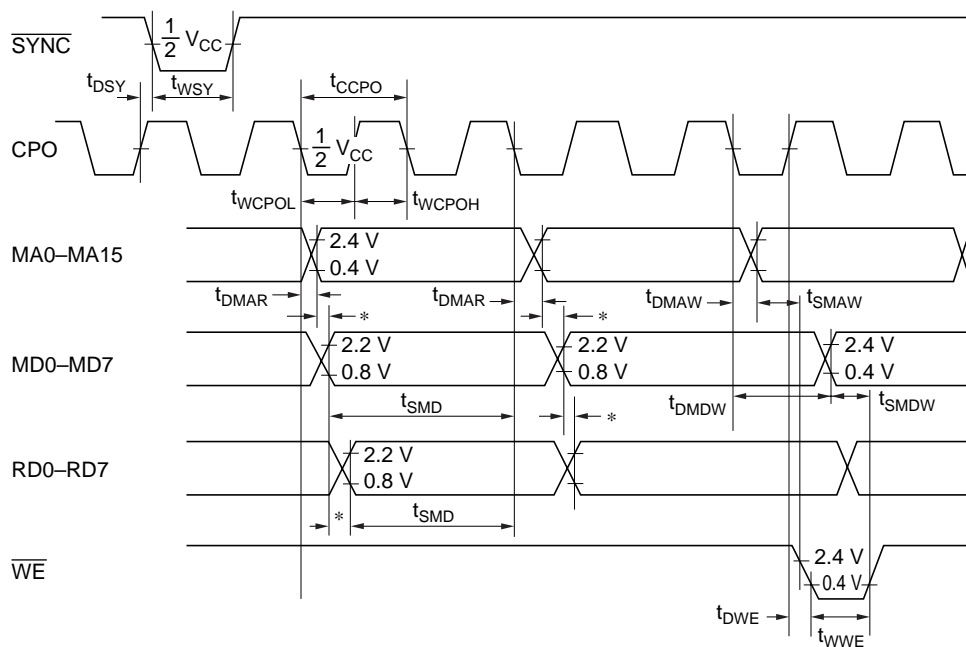

- Notes: 1. No load is applied to all the output terminals.  
 2. "\*" indicates the delay time of RAM and ROM.

# HD61830/HD61830B

HD61830 LCD Driver Interface ( $V_{CC} = 5\text{ V} \pm 10\%$ ,  $GND = 0\text{ V}$ ,  $T_a = -20\text{ to }+75^\circ\text{C}$ )

Item	Symbol	Min	Typ	Max	Unit
Clock pulse width (high level)	$t_{WCL1}$	450	—	—	ns
Clock delay time	$t_{DCL2}$	—	—	200	ns
Clock cycle time	$t_{WCL2}$	900	—	—	ns
Clock pulse width	High level	$t_{WCH}$	450	—	ns
	Low level	$t_{WCL}$	450	—	ns
MA, MB delay time	$t_{DM}$	—	—	300	ns
FLM delay time	$t_{DF}$	—	—	300	ns
Data delay time	$t_{DD}$	—	—	200	ns
Data setup time	$t_{SD}$	250	—	—	ns

Note: No load is applied to all the output terminals (MA, MB, FLM, D1, and D2).

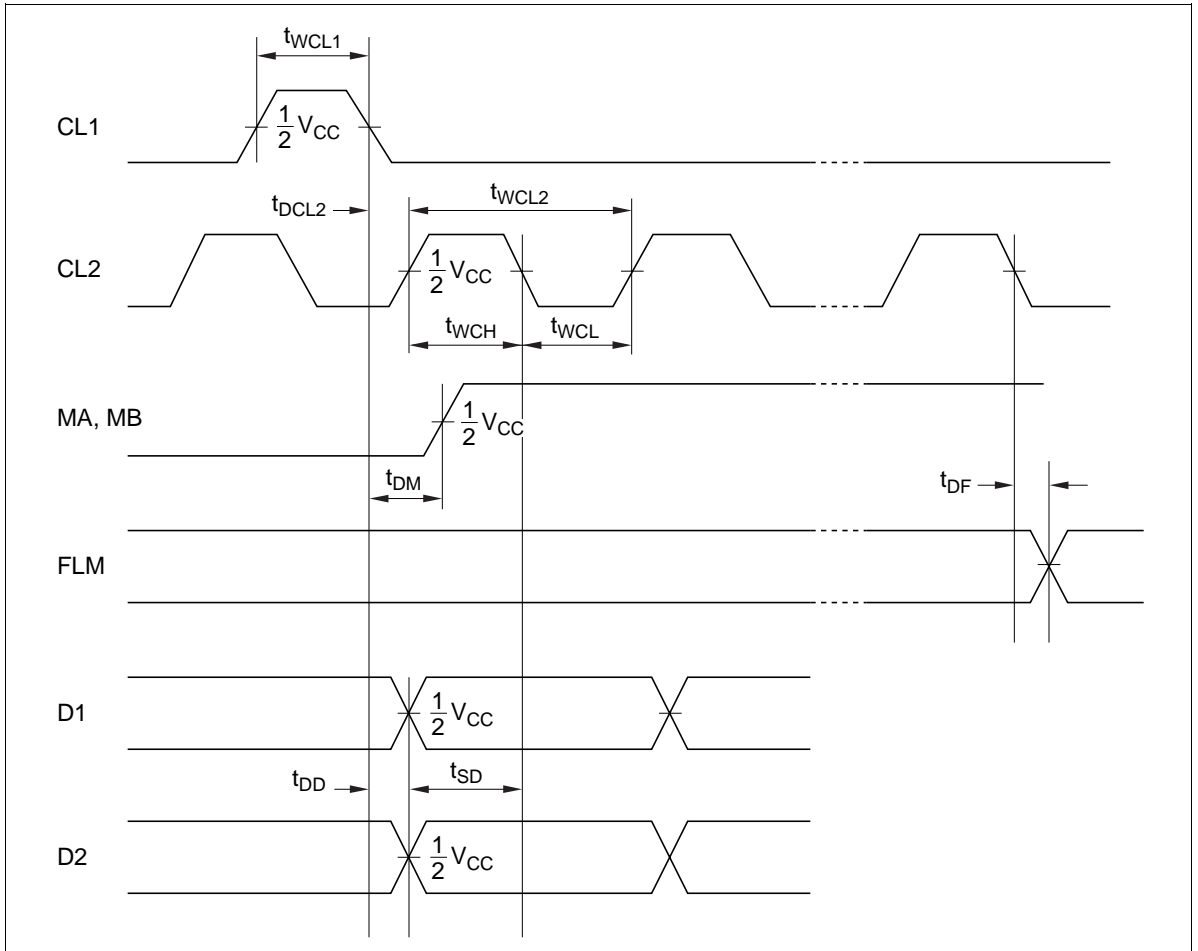



## HD61830B Absolute Maximum Ratings

Item	Symbol	Value	Unit	Notes
Supply voltage	$V_{CC}$	-0.3 to +0.7	V	1, 2
Terminal voltage	VT	-0.3 to $V_{CC} + 0.3$	V	1, 2
Operating temperature	$T_{opr}$	-20 to +75	°C	
Storage temperature	$T_{stg}$	-55 to +125	°C	

Notes: 1. All voltage is referred to GND = 0 V.

2. If LSIs are used beyond absolute maximum ratings, they may be permanently destroyed.

We strongly recommend that you use the LSIs within electrical characteristic limits for normal operation, because use beyond these conditions will cause malfunction and poor reliability.

## HD61830B Electrical Characteristics ( $V_{CC} = 5V \pm 10\%$ , $GND = 0V$ , $T_a = -20$ to $+75^\circ C$ )

Item	Symbol	Min	Typ	Max	Unit	Test Condition	Notes
Input high voltage (TTL)	$V_{IH}$	2.2	—	$V_{CC}$	V		1
Input low voltage (TTL)	$V_{IL}$	0	—	0.8	V		2
Input high voltage	$V_{IHR}$	3.0	—	$V_{CC}$	V		3
Input high voltage (CMOS)	$V_{IHC}$	$0.7 V_{CC}$	—	$V_{CC}$	V		4
Input low voltage (CMOS)	$V_{ILC}$	0	—	$0.3 V_{CC}$	V		4
Output high voltage (TTL)	$V_{OH}$	2.4	—	$V_{CC}$	V	$-I_{OH} = 0.6 \text{ mA}$	5
Output low voltage (TTL)	$V_{OL}$	0	—	0.4	V	$I_{OL} = 1.6 \text{ mA}$	5
Output high voltage (CMOS)	$V_{OHC}$	$V_{CC} - 0.4$	—	$V_{CC}$	V	$-I_{OH} = 0.6 \text{ mA}$	6
Output low voltage (CMOS)	$V_{OLC}$	0	—	0.4	V	$I_{OI} = 0.6 \text{ mA}$	6
Input leakage current	$I_{IN}$	-5	—	5	$\mu A$	$V_{IN} = 0 - V_{CC}$	7
Three-state leakage current	$I_{TSL}$	-10	—	10	$\mu A$	$V_{OUT} = 0 - V_{CC}$	8
Pull-up current	$I_{PL}$	2	10	20	$\mu A$	$V_{in} = GND$	9
Power dissipation	$P_W$	—	—	50	mW	External clock $f_{cp} = 2.4 \text{ MHz}$	10

- Notes:
1. Applied to input terminals and I/O common terminals, except terminals  $\overline{SYNC}$ , CR, and  $\overline{RES}$ .
  2. Applied to input terminals and I/O common terminals, except terminals  $\overline{SYNC}$  and CR.
  3. Applied to terminal  $\overline{RES}$ .
  4. Applied to terminals  $\overline{SYNC}$  and CR.
  5. Applied to terminals DB0–DB7,  $\overline{WE}$ , MA0–MA15,  $\overline{OE}$ ,  $\overline{CE}$ , and MD0–MD7.
  6. Applied to terminals  $\overline{SYNC}$ , FLM, CL1, CL2, D1, D2, MA, and MB.
  7. Applied to input terminals.
  8. Applied to I/O common terminals. However, the current which flows into the output drive MOS is excluded.
  9. Applied to  $\overline{SYNC}$ , DB0–DB7, and RD0–RD7.
  10. The current which flows into the input and output circuits is excluded. When the input of CMOS is in the intermediate level, current flows through the input circuit, resulting in the increase of power supply current. To avoid this, input must be fixed at high or low.

**Input Terminal**

Applicable terminal:  $\overline{CS}$ , E, RS, R/W,  $\overline{RES}$ , CR (without pull-up MOS)

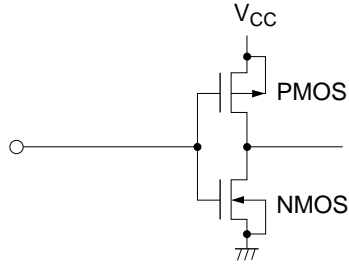

Applicable terminal: RD0–RD7 (with pull-up MOS)

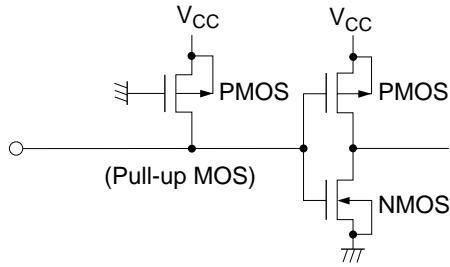

## Output Terminal

Applicable terminal: CL1, CL2, MA, MB, FLM, D1, D2,  $\overline{WE}$ ,  $\overline{OE}$ ,  $\overline{CE}$ , MA0-MA15

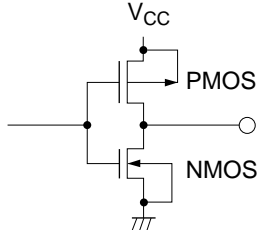

## I/O Common Terminal

Applicable terminal: DB0-DB7,  $\overline{SYNC}$ , MD0-MD7 (MD0-MD7 have no pull-up MOS)

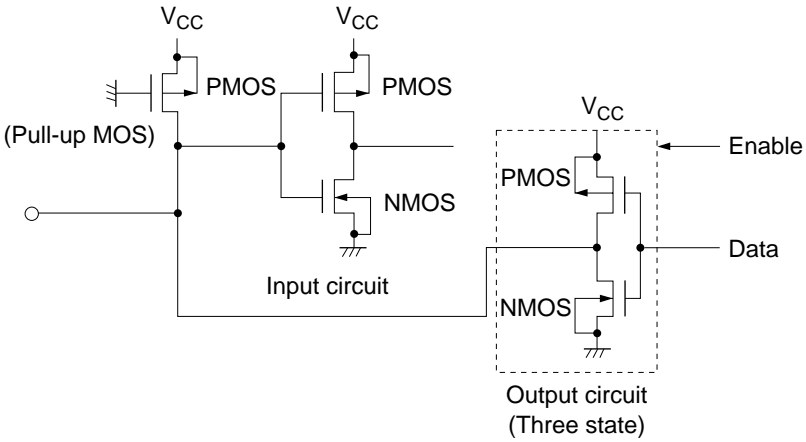

## Timing Characteristics

HD61830B Clock Operation ( $V_{CC} = 5\text{ V} \pm 10\%$ ,  $GND = 0\text{V}$ ,  $T_a = -20\text{ to } +75^\circ\text{C}$ )

Item	Symbol	Min	Typ	Max	Unit	Notes
External clock operating frequency	$f_{cp}$	100	—	2400	kHz	1
External clock duty	Duty	47.5	50	52.5	%	1
External clock rise time	$t_{rcp}$	—	—	25.0	ns	1
External clock fall time	$t_{fcp}$	—	—	25.0	ns	1
$\overline{\text{SYNC}}$ output hold time	$t_{HSYO}$	30	—	—	ns	2, 3
$\overline{\text{SYNC}}$ output delay time	$t_{DSY}$	—	—	210	ns	2, 3
$\overline{\text{SYNC}}$ input hold time	$t_{HSYI}$	10	—	—	ns	2
$\overline{\text{SYNC}}$ input set-up time	$t_{SSY}$	—	—	180	ns	2

Notes: 1. Applied to external clock input terminal.

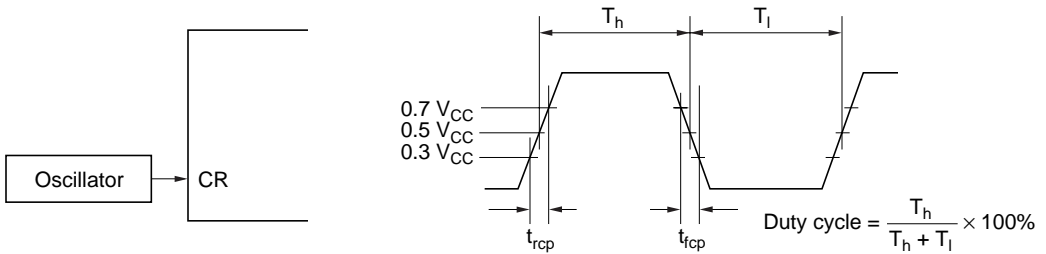

2. Applied to  $\overline{\text{SYNC}}$  terminal.

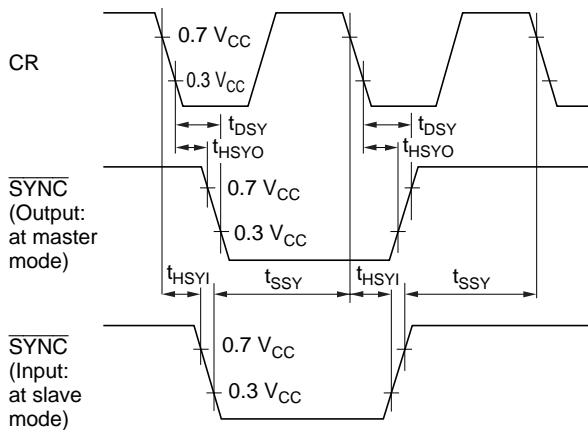

3. Testing load circuit.

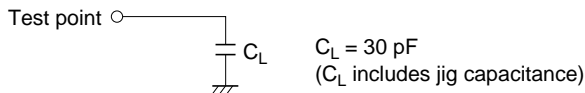

# HD61830/HD61830B

HD61830B MPU Interface ( $V_{CC} = 5V \pm 10\%$ ,  $GND = 0V$ ,  $T_a = -20$  to  $+75^\circ C$ )

Item	Symbol	Min	Typ	Max	Unit
Enable cycle time	$t_{CYC}$	1.0	—	—	$\mu s$
Enable pulse width	High level	$t_{WEH}$	0.45	—	$\mu s$
	Low level	$t_{WEL}$	0.45	—	$\mu s$
Enable rise time	$t_{Er}$	—	—	25	ns
Enable fall time	$t_{Ef}$	—	—	25	ns
Setup time	$t_{AS}$	140	—	—	ns
Data setup time	$t_{DSW}$	225	—	—	ns
Data delay time	$t_{DDR}$	—	—	225	ns *
Data hold time	$t_{DHW}$	10	—	—	ns
Address hold time	$t_{AH}$	10	—	—	ns
Output data hold time	$t_{DH}$	20	—	—	ns

Note: \* The following load circuit is connected for specification:

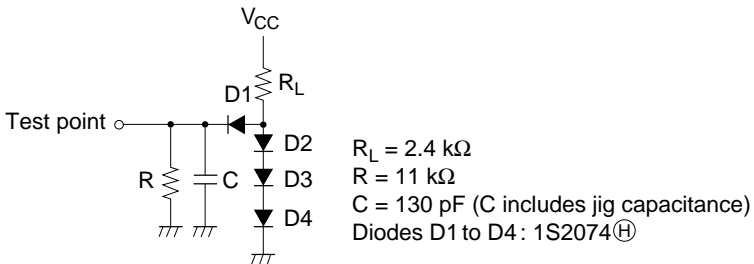
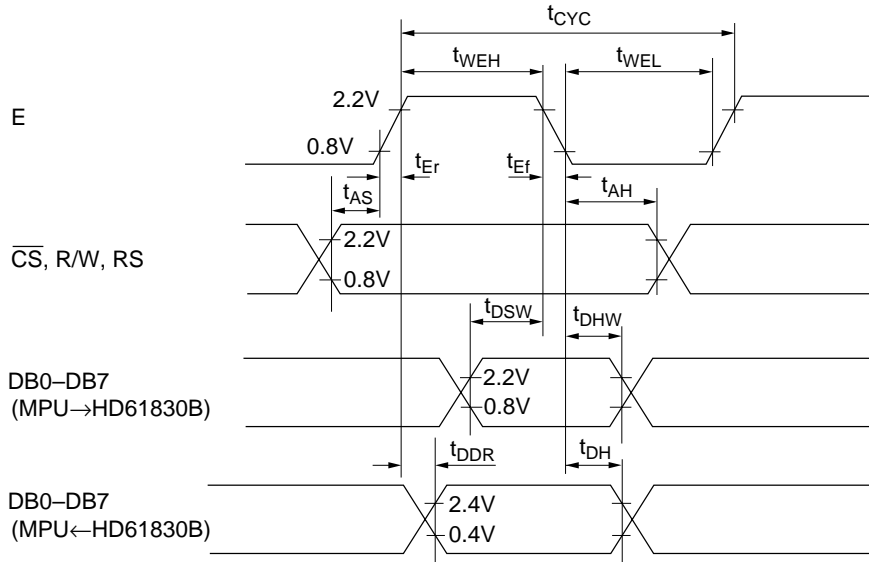

## HD61830B External RAM and ROM Interface ( $V_{CC} = 5V \pm 10\%$ , $GND = 0V$ , $T_a = -20$ to $+75^\circ C$ )

Item	Symbol	Min	Typ	Max	Unit	Notes
MA0–MA15 delay time	$t_{DMA}$	—	—	300	ns	1, 2, 3
MA0–MA15 hold time	$t_{HMA}$	40	—	—	ns	1, 2, 3
$\overline{CE}$ delay time	$t_{DCE}$	—	—	300	ns	1, 2, 3
$\overline{CE}$ hold time	$t_{HCE}$	40	—	—	ns	1, 2, 3
$\overline{OE}$ delay time	$t_{DOE}$	—	—	300	ns	1, 3
$\overline{OE}$ hold time	$t_{HOE}$	40	—	—	ns	1, 3
MD output delay time	$t_{DMD}$	—	—	150	ns	1, 3
MD output hold time	$t_{HMDW}$	10	—	—	ns	1, 3
$\overline{WE}$ delay time	$t_{DWE}$	—	—	150	ns	1, 3
$\overline{WE}$ clock pulse width	$t_{WWE}$	150	—	—	ns	1, 3
MD output high impedance time (1)	$t_{ZMDF}$	10	—	—	ns	1, 3
MD output high impedance time (2)	$t_{ZMDR}$	50	—	—	ns	1, 3
RD data set-up time	$t_{SRD}$	50	—	—	ns	2
RD data hold time	$t_{HRD}$	40	—	—	ns	2
MD data set-up time	$t_{SMD}$	50	—	—	ns	2
MD data hold time	$t_{HMD}$	40	—	—	ns	2

Notes: 1. RAM write timing

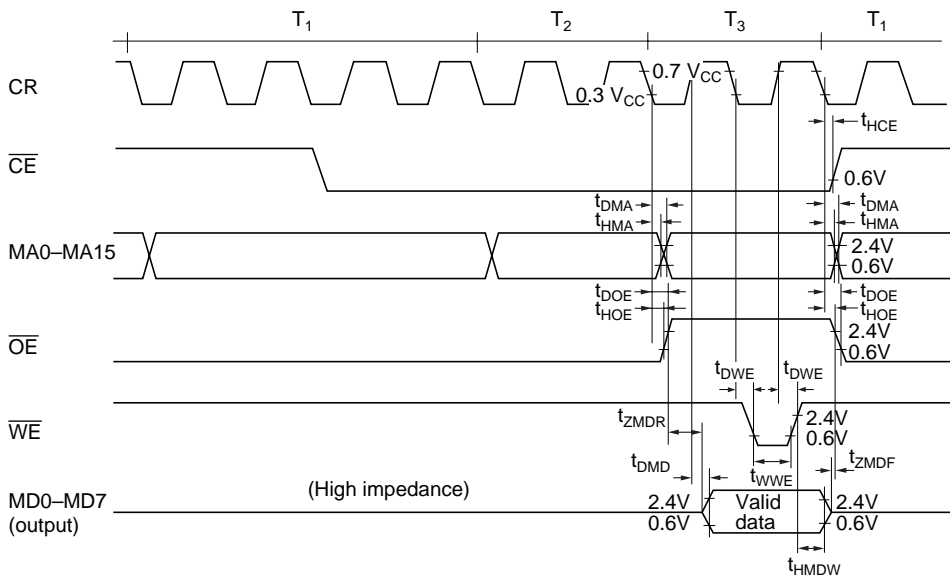

T1: Memory data refresh timing for upper screen

T2: Memory data refresh timing for lower screen

T3: Memory read/write timing

## 2. ROM/RAM read timing

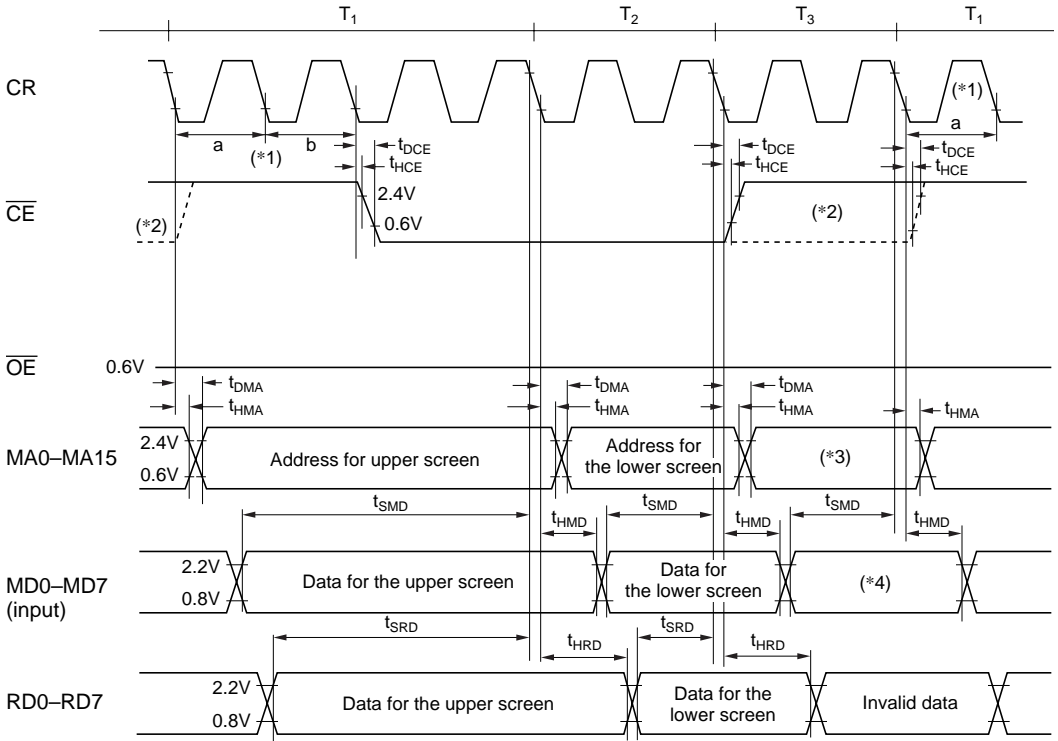

\*1 This figures shows the timing for  $H_p = 8$ .

For  $H_p = 7$ , time shown by "b" becomes zero. For  $H_p = 6$ , time shown by "a" and "b" become zero.

Therefore, the number of clock pulses during T1 become 4, 3, or 2 in the case of  $H_p = 8$ ,  $H_p = 7$ , or  $H_p = 6$  respectively.

\*2 The waveform for instructions with memory read is shown with a dash line. In other cases, the waveform shown with a solid line is generated.

\*3 When an instruction with RAM read/write is executed, the value of cursor address is output. In other cases, invalid data is output.

\*4 When an instruction with RAM read is executed, HD61830B latches the data at this timing. In other cases, this data is invalid.

## 3. Test load circuit

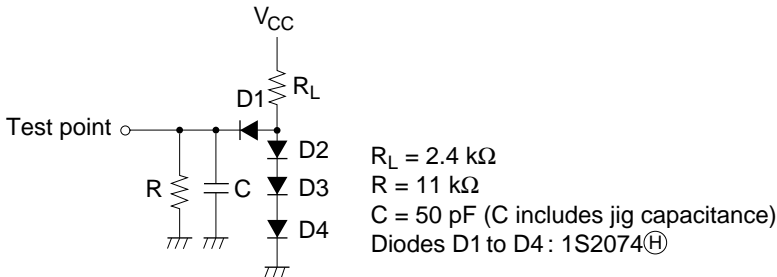



**HD61830B LCD Driver Interface ( $V_{CC} = 5V \pm 10\%$ ,  $GND = 0V$ ,  $T_a = -20$  to  $+75^\circ C$ )**

<b>Item</b>	<b>Symbol</b>	<b>Min</b>	<b>Typ</b>	<b>Max</b>	<b>Unit</b>	<b>Notes</b>
Clock cycle time	$t_{WCL2}$	416	—	—	ns	1, 3
Clock pulse width(high level)	$t_{WCH}$	150	—	—	ns	1, 3
Clock pulse width(low level)	$t_{WCL}$	150	—	—	ns	1, 3
Data delay time	$t_{DD}$	—	—	50	ns	1, 3
Data hold time	$t_{DH}$	100	—	—	ns	1, 3
Clock phase difference (1)	$t_{CL1}$	100	—	—	ns	1, 3
Clock phase difference (2)	$t_{CL2}$	100	—	—	ns	1, 3
Clock phase difference (3)	$t_{CL3}$	100	—	—	ns	1, 3
MA, MB delay time	$t_{DM}$	-200	—	200	ns	1, 3
FLM set-up time	$t_{SF}$	400	—	—	ns	2, 3
FLM hold time	$t_{HF}$	1000	—	—	ns	2, 3
MA set-up time	$t_{SMA}$	400	—	—	ns	2, 3
MA hold time	$t_{HMA}$	1000	—	—	ns	2, 3

Notes: 1.

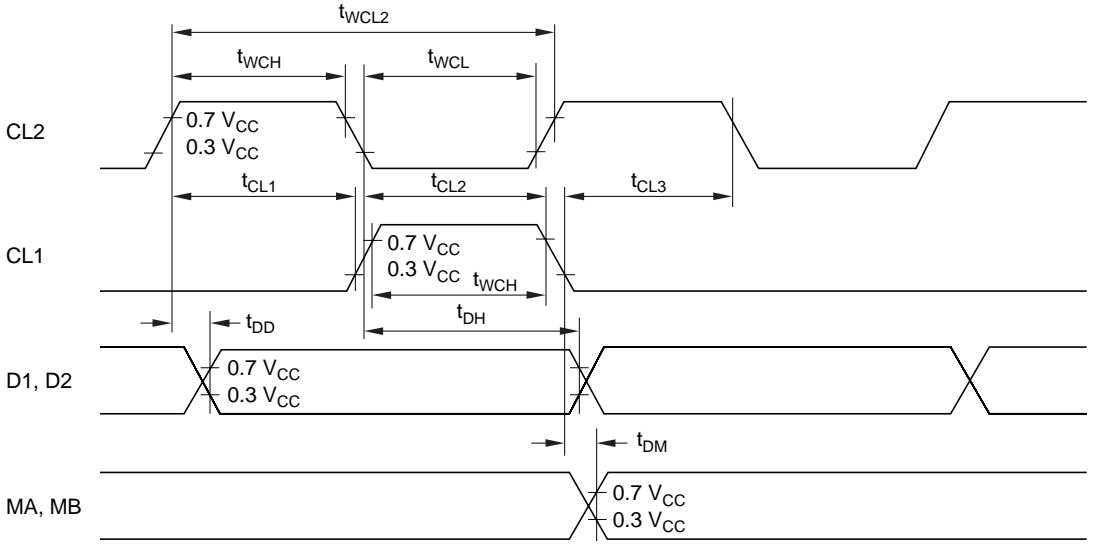

2.

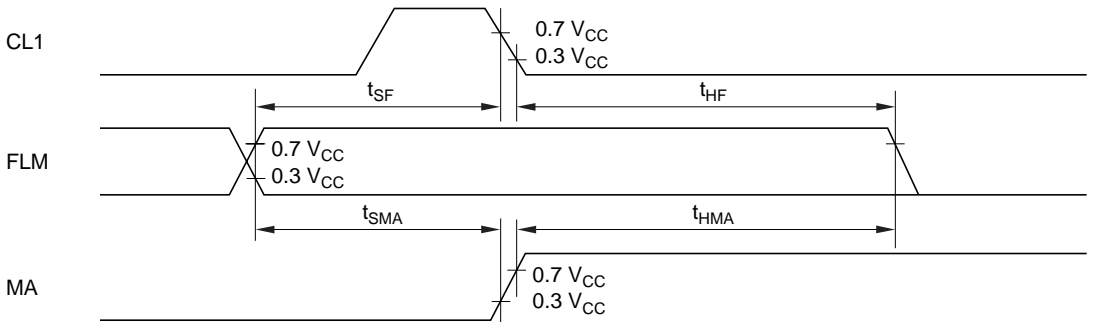

3. Test load circuit

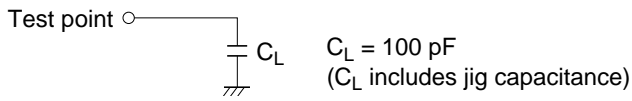

## Cautions

1. Hitachi neither warrants nor grants licenses of any rights of Hitachi's or any third party's patent, copyright, trademark, or other intellectual property rights for information contained in this document. Hitachi bears no responsibility for problems that may arise with third party's rights, including intellectual property rights, in connection with use of the information contained in this document.
2. Products and product specifications may be subject to change without notice. Confirm that you have received the latest product standards or specifications before final design, purchase or use.
3. Hitachi makes every attempt to ensure that its products are of high quality and reliability. However, contact Hitachi's sales office before using the product in an application that demands especially high quality and reliability or where its failure or malfunction may directly threaten human life or cause risk of bodily injury, such as aerospace, aeronautics, nuclear power, combustion control, transportation, traffic, safety equipment or medical equipment for life support.
4. Design your application so that the product is used within the ranges guaranteed by Hitachi particularly for maximum rating, operating supply voltage range, heat radiation characteristics, installation conditions and other characteristics. Hitachi bears no responsibility for failure or damage when used beyond the guaranteed ranges. Even within the guaranteed ranges, consider normally foreseeable failure rates or failure modes in semiconductor devices and employ systemic measures such as fail-safes, so that the equipment incorporating Hitachi product does not cause bodily injury, fire or other consequential damage due to operation of the Hitachi product.
5. This product is not designed to be radiation resistant.
6. No one is permitted to reproduce or duplicate, in any form, the whole or part of this document without written approval from Hitachi.
7. Contact Hitachi's sales office for any questions regarding this document or Hitachi semiconductor products.

# HITACHI

## Hitachi, Ltd.

Semiconductor & Integrated Circuits.  
Nippon Bldg., 2-6-2, Ohte-machi, Chiyoda-ku, Tokyo 100-0004, Japan  
Tel: Tokyo (03) 3270-2111 Fax: (03) 3270-5109

URL	North America	: <a href="http://semiconductor.hitachi.com/">http://semiconductor.hitachi.com/</a>
	Europe	: <a href="http://www.hitachi-eu.com/hel/ecg">http://www.hitachi-eu.com/hel/ecg</a>
	Asia (Singapore)	: <a href="http://www.has.hitachi.com.sg/grp3/sicd/index.htm">http://www.has.hitachi.com.sg/grp3/sicd/index.htm</a>
	Asia (Taiwan)	: <a href="http://www.hitachi.com.tw/E/Product/SICD_Frame.htm">http://www.hitachi.com.tw/E/Product/SICD_Frame.htm</a>
	Asia (HongKong)	: <a href="http://www.hitachi.com.hk/eng/bo/grp3/index.htm">http://www.hitachi.com.hk/eng/bo/grp3/index.htm</a>
	Japan	: <a href="http://www.hitachi.co.jp/Sicd/indx.htm">http://www.hitachi.co.jp/Sicd/indx.htm</a>

## For further information write to:

Hitachi Semiconductor  
(America) Inc.  
179 East Tasman Drive,  
San Jose, CA 95134  
Tel: <1> (408) 433-1990  
Fax: <1> (408) 433-0223

Hitachi Europe GmbH  
Electronic components Group  
Dornacher Straße 3  
D-85622 Feldkirchen, Munich  
Germany  
Tel: <49> (89) 9 9180-0  
Fax: <49> (89) 9 29 30 00

Hitachi Europe Ltd.  
Electronic Components Group.  
Whitebrook Park  
Lower Cookham Road  
Maidenhead  
Berkshire SL6 8YA, United Kingdom  
Tel: <44> (1628) 585000  
Fax: <44> (1628) 778322

Hitachi Asia Pte. Ltd.  
16 Collyer Quay #20-00  
Hitachi Tower  
Singapore 049318  
Tel: 535-2100  
Fax: 535-1533

Hitachi Asia Ltd.  
Taipei Branch Office  
3F, Hung Kuo Building, No.167,  
Tun-Hwa North Road, Taipei (105)  
Tel: <886> (2) 2718-3666  
Fax: <886> (2) 2718-8180

Hitachi Asia (Hong Kong) Ltd.  
Group III (Electronic Components)  
7/F., North Tower, World Finance Centre,  
Harbour City, Canton Road, Tsim Sha Tsui,  
Kowloon, Hong Kong  
Tel: <852> (2) 735 9218  
Fax: <852> (2) 730 0281  
Telex: 40815 HITEC HX

Copyright © Hitachi, Ltd., 1998. All rights reserved. Printed in Japan.