

To our customers,

Old Company Name in Catalogs and Other Documents

On April 1st, 2010, NEC Electronics Corporation merged with Renesas Technology Corporation, and Renesas Electronics Corporation took over all the business of both companies. Therefore, although the old company name remains in this document, it is a valid Renesas Electronics document. We appreciate your understanding.

Renesas Electronics website: <http://www.renesas.com>

April 1st, 2010
Renesas Electronics Corporation

Issued by: Renesas Electronics Corporation (<http://www.renesas.com>)

Send any inquiries to <http://www.renesas.com/inquiry>.

Notice

1. All information included in this document is current as of the date this document is issued. Such information, however, is subject to change without any prior notice. Before purchasing or using any Renesas Electronics products listed herein, please confirm the latest product information with a Renesas Electronics sales office. Also, please pay regular and careful attention to additional and different information to be disclosed by Renesas Electronics such as that disclosed through our website.
2. Renesas Electronics does not assume any liability for infringement of patents, copyrights, or other intellectual property rights of third parties by or arising from the use of Renesas Electronics products or technical information described in this document. No license, express, implied or otherwise, is granted hereby under any patents, copyrights or other intellectual property rights of Renesas Electronics or others.
3. You should not alter, modify, copy, or otherwise misappropriate any Renesas Electronics product, whether in whole or in part.
4. Descriptions of circuits, software and other related information in this document are provided only to illustrate the operation of semiconductor products and application examples. You are fully responsible for the incorporation of these circuits, software, and information in the design of your equipment. Renesas Electronics assumes no responsibility for any losses incurred by you or third parties arising from the use of these circuits, software, or information.
5. When exporting the products or technology described in this document, you should comply with the applicable export control laws and regulations and follow the procedures required by such laws and regulations. You should not use Renesas Electronics products or the technology described in this document for any purpose relating to military applications or use by the military, including but not limited to the development of weapons of mass destruction. Renesas Electronics products and technology may not be used for or incorporated into any products or systems whose manufacture, use, or sale is prohibited under any applicable domestic or foreign laws or regulations.
6. Renesas Electronics has used reasonable care in preparing the information included in this document, but Renesas Electronics does not warrant that such information is error free. Renesas Electronics assumes no liability whatsoever for any damages incurred by you resulting from errors in or omissions from the information included herein.
7. Renesas Electronics products are classified according to the following three quality grades: "Standard", "High Quality", and "Specific". The recommended applications for each Renesas Electronics product depends on the product's quality grade, as indicated below. You must check the quality grade of each Renesas Electronics product before using it in a particular application. You may not use any Renesas Electronics product for any application categorized as "Specific" without the prior written consent of Renesas Electronics. Further, you may not use any Renesas Electronics product for any application for which it is not intended without the prior written consent of Renesas Electronics. Renesas Electronics shall not be in any way liable for any damages or losses incurred by you or third parties arising from the use of any Renesas Electronics product for an application categorized as "Specific" or for which the product is not intended where you have failed to obtain the prior written consent of Renesas Electronics. The quality grade of each Renesas Electronics product is "Standard" unless otherwise expressly specified in a Renesas Electronics data sheets or data books, etc.

"Standard": Computers; office equipment; communications equipment; test and measurement equipment; audio and visual equipment; home electronic appliances; machine tools; personal electronic equipment; and industrial robots.

"High Quality": Transportation equipment (automobiles, trains, ships, etc.); traffic control systems; anti-disaster systems; anti-crime systems; safety equipment; and medical equipment not specifically designed for life support.

"Specific": Aircraft; aerospace equipment; submersible repeaters; nuclear reactor control systems; medical equipment or systems for life support (e.g. artificial life support devices or systems), surgical implantations, or healthcare intervention (e.g. excision, etc.), and any other applications or purposes that pose a direct threat to human life.

8. You should use the Renesas Electronics products described in this document within the range specified by Renesas Electronics, especially with respect to the maximum rating, operating supply voltage range, movement power voltage range, heat radiation characteristics, installation and other product characteristics. Renesas Electronics shall have no liability for malfunctions or damages arising out of the use of Renesas Electronics products beyond such specified ranges.
9. Although Renesas Electronics endeavors to improve the quality and reliability of its products, semiconductor products have specific characteristics such as the occurrence of failure at a certain rate and malfunctions under certain use conditions. Further, Renesas Electronics products are not subject to radiation resistance design. Please be sure to implement safety measures to guard them against the possibility of physical injury, and injury or damage caused by fire in the event of the failure of a Renesas Electronics product, such as safety design for hardware and software including but not limited to redundancy, fire control and malfunction prevention, appropriate treatment for aging degradation or any other appropriate measures. Because the evaluation of microcomputer software alone is very difficult, please evaluate the safety of the final products or system manufactured by you.
10. Please contact a Renesas Electronics sales office for details as to environmental matters such as the environmental compatibility of each Renesas Electronics product. Please use Renesas Electronics products in compliance with all applicable laws and regulations that regulate the inclusion or use of controlled substances, including without limitation, the EU RoHS Directive. Renesas Electronics assumes no liability for damages or losses occurring as a result of your noncompliance with applicable laws and regulations.
11. This document may not be reproduced or duplicated, in any form, in whole or in part, without prior written consent of Renesas Electronics.
12. Please contact a Renesas Electronics sales office if you have any questions regarding the information contained in this document or Renesas Electronics products, or if you have any other inquiries.

(Note 1) "Renesas Electronics" as used in this document means Renesas Electronics Corporation and also includes its majority-owned subsidiaries.

(Note 2) "Renesas Electronics product(s)" means any product developed or manufactured by or for Renesas Electronics.

H8/3694 Group

Hardware Manual

Renesas 16-Bit Single-Chip
Microcomputer

H8 Family/H8/300H Tiny Series

| | |
|----------|-------------------------|
| H8/3694N | HD64N3694G, HD6483694G, |
| H8/3694F | HD64F3694, HD64F3694G, |
| H8/3694 | HD6433694, HD6433694G, |
| H8/3693 | HD6433693, HD6433693G, |
| H8/3692 | HD6433692, HD6433692G, |
| H8/3691 | HD6433691, HD6433691G, |
| H8/3690 | HD6433690, HD6433690G |

Keep safety first in your circuit designs!

1. Renesas Technology Corp. puts the maximum effort into making semiconductor products better and more reliable, but there is always the possibility that trouble may occur with them. Trouble with semiconductors may lead to personal injury, fire or property damage.
Remember to give due consideration to safety when making your circuit designs, with appropriate measures such as (i) placement of substitutive, auxiliary circuits, (ii) use of nonflammable material or (iii) prevention against any malfunction or mishap.

Notes regarding these materials

1. These materials are intended as a reference to assist our customers in the selection of the Renesas Technology Corp. product best suited to the customer's application; they do not convey any license under any intellectual property rights, or any other rights, belonging to Renesas Technology Corp. or a third party.
2. Renesas Technology Corp. assumes no responsibility for any damage, or infringement of any third-party's rights, originating in the use of any product data, diagrams, charts, programs, algorithms, or circuit application examples contained in these materials.
3. All information contained in these materials, including product data, diagrams, charts, programs and algorithms represents information on products at the time of publication of these materials, and are subject to change by Renesas Technology Corp. without notice due to product improvements or other reasons. It is therefore recommended that customers contact Renesas Technology Corp. or an authorized Renesas Technology Corp. product distributor for the latest product information before purchasing a product listed herein.
The information described here may contain technical inaccuracies or typographical errors.
Renesas Technology Corp. assumes no responsibility for any damage, liability, or other loss rising from these inaccuracies or errors.
Please also pay attention to information published by Renesas Technology Corp. by various means, including the Renesas Technology Corp. Semiconductor home page (<http://www.renesas.com>).
4. When using any or all of the information contained in these materials, including product data, diagrams, charts, programs, and algorithms, please be sure to evaluate all information as a total system before making a final decision on the applicability of the information and products. Renesas Technology Corp. assumes no responsibility for any damage, liability or other loss resulting from the information contained herein.
5. Renesas Technology Corp. semiconductors are not designed or manufactured for use in a device or system that is used under circumstances in which human life is potentially at stake. Please contact Renesas Technology Corp. or an authorized Renesas Technology Corp. product distributor when considering the use of a product contained herein for any specific purposes, such as apparatus or systems for transportation, vehicular, medical, aerospace, nuclear, or undersea repeater use.
6. The prior written approval of Renesas Technology Corp. is necessary to reprint or reproduce in whole or in part these materials.
7. If these products or technologies are subject to the Japanese export control restrictions, they must be exported under a license from the Japanese government and cannot be imported into a country other than the approved destination.
Any diversion or reexport contrary to the export control laws and regulations of Japan and/or the country of destination is prohibited.
8. Please contact Renesas Technology Corp. for further details on these materials or the products contained therein.

General Precautions on Handling of Product

1. Treatment of NC Pins

Note: Do not connect anything to the NC pins.

The NC (not connected) pins are either not connected to any of the internal circuitry or are used as test pins or to reduce noise. If something is connected to the NC pins, the operation of the LSI is not guaranteed.

2. Treatment of Unused Input Pins

Note: Fix all unused input pins to high or low level.

Generally, the input pins of CMOS products are high-impedance input pins. If unused pins are in their open states, intermediate levels are induced by noise in the vicinity, a pass-through current flows internally, and a malfunction may occur.

3. Processing before Initialization

Note: When power is first supplied, the product's state is undefined.

The states of internal circuits are undefined until full power is supplied throughout the chip and a low level is input on the reset pin. During the period where the states are undefined, the register settings and the output state of each pin are also undefined. Design your system so that it does not malfunction because of processing while it is in this undefined state. For those products which have a reset function, reset the LSI immediately after the power supply has been turned on.

4. Prohibition of Access to Undefined or Reserved Addresses

Note: Access to undefined or reserved addresses is prohibited.

The undefined or reserved addresses may be used to expand functions, or test registers may have been allocated to these addresses. Do not access these registers; the system's operation is not guaranteed if they are accessed.

Configuration of This Manual

This manual comprises the following items:

1. General Precautions on Handling of Product
2. Configuration of This Manual
3. Preface
4. Contents
5. Overview
6. Description of Functional Modules
 - CPU and System-Control Modules
 - On-Chip Peripheral Modules

The configuration of the functional description of each module differs according to the module. However, the generic style includes the following items:

 - i) Feature
 - ii) Input/Output Pin
 - iii) Register Description
 - iv) Operation
 - v) Usage Note

When designing an application system that includes this LSI, take notes into account. Each section includes notes in relation to the descriptions given, and usage notes are given, as required, as the final part of each section.

7. List of Registers
8. Electrical Characteristics
9. Appendix
10. Main Revisions and Additions in this Edition (only for revised versions)

The list of revisions is a summary of points that have been revised or added to earlier versions. This does not include all of the revised contents. For details, see the actual locations in this manual.

11. Index

Preface

The H8/3694 Group are single-chip microcomputers made up of the high-speed H8/300H CPU employing Renesas Technology original architecture as their cores, and the peripheral functions required to configure a system. The H8/300H CPU has an instruction set that is compatible with the H8/300 CPU.

Target Users: This manual was written for users who will be using the H8/3694 Group in the design of application systems. Target users are expected to understand the fundamentals of electrical circuits, logical circuits, and microcomputers.

Objective: This manual was written to explain the hardware functions and electrical characteristics of the H8/3694 Group to the target users.
Refer to the H8/300H Series Software Manual for a detailed description of the instruction set.

Notes on reading this manual:

- In order to understand the overall functions of the chip
Read the manual according to the contents. This manual can be roughly categorized into parts on the CPU, system control functions, peripheral functions and electrical characteristics.
- In order to understand the details of the CPU's functions
Read the H8/300H Series Software Manual.
- In order to understand the details of a register when its name is known
Read the index that is the final part of the manual to find the page number of the entry on the register. The addresses, bits, and initial values of the registers are summarized in section 20, List of Registers.
Example: Bit order: The MSB is on the left and the LSB is on the right.

Notes:

When using the on-chip emulator (E7, E8) for H8/3694 program development and debugging, the following restrictions must be noted.

1. The $\overline{\text{NMI}}$ pin is reserved for the E7 or E8, and cannot be used.
2. Pins P85, P86, and P87 cannot be used. In order to use these pins, additional hardware must be provided on the user board.
3. Area H'7000 to H'7FFF is used by the E7 or E8, and is not available to the user.
4. Area H'F780 to H'FB7F must on no account be accessed.

5. When the E7 or E8 is used, address breaks can be set as either available to the user or for use by the E7 or E8. If address breaks are set as being used by the E7 or E8, the address break control registers must not be accessed.
6. When the E7 or E8 is used, NMI is an input/output pin (open-drain in output mode), P85 and P87 are input pins, and P86 is an output pin.

Related Manuals: The latest versions of all related manuals are available from our web site. Please ensure you have the latest versions of all documents you require.
<http://www.renesas.com/>

H8/3694 Group manuals:

| Document Title | Document No. |
|--------------------------------|---------------------|
| H8/3694 Group Hardware Manual | This manual |
| H8/300H Series Software Manual | REJ09B0213 |

User's manuals for development tools:

| Document Title | Document No. |
|--|---------------------|
| H8S, H8/300 Series C/C++ Compiler, Assembler, Optimizing Linkage Editor User's Manual | REJ10B0058 |
| Microcomputer Development Environment System H8S, H8/300 Series Simulator/Debugger User's Manual | ADE-702-282 |
| H8S, H8/300 Series High-Performance Embedded Workshop 3, Tutorial | REJ10B0024 |
| H8S, H8/300 Series High-Performance Embedded Workshop 3, User's Manual | REJ10B0026 |

Application notes:

| Document Title | Document No. |
|--|---------------------|
| H8S, H8/300 Series C/C++ Compiler Package Application Note | REJ05B0464 |
| Single Power Supply F-ZTAT™ On-Board Programming | ADE-502-055 |

Contents

| | |
|---|----|
| Section 1 Overview..... | 1 |
| 1.1 Features..... | 1 |
| 1.2 Internal Block Diagram..... | 4 |
| 1.3 Pin Arrangement..... | 6 |
| 1.4 Pin Functions..... | 9 |
| Section 2 CPU..... | 13 |
| 2.1 Address Space and Memory Map..... | 14 |
| 2.2 Register Configuration..... | 17 |
| 2.2.1 General Registers..... | 18 |
| 2.2.2 Program Counter (PC)..... | 19 |
| 2.2.3 Condition-Code Register (CCR)..... | 19 |
| 2.3 Data Formats..... | 21 |
| 2.3.1 General Register Data Formats..... | 21 |
| 2.3.2 Memory Data Formats..... | 23 |
| 2.4 Instruction Set..... | 24 |
| 2.4.1 Table of Instructions Classified by Function..... | 24 |
| 2.4.2 Basic Instruction Formats..... | 33 |
| 2.5 Addressing Modes and Effective Address Calculation..... | 34 |
| 2.5.1 Addressing Modes..... | 34 |
| 2.5.2 Effective Address Calculation..... | 38 |
| 2.6 Basic Bus Cycle..... | 40 |
| 2.6.1 Access to On-Chip Memory (RAM, ROM)..... | 40 |
| 2.6.2 On-Chip Peripheral Modules..... | 41 |
| 2.7 CPU States..... | 42 |
| 2.8 Usage Notes..... | 43 |
| 2.8.1 Notes on Data Access to Empty Areas..... | 43 |
| 2.8.2 EEPMOV Instruction..... | 43 |
| 2.8.3 Bit Manipulation Instruction..... | 43 |
| Section 3 Exception Handling..... | 49 |
| 3.1 Exception Sources and Vector Address..... | 49 |
| 3.2 Register Descriptions..... | 51 |
| 3.2.1 Interrupt Edge Select Register 1 (IEGR1)..... | 51 |
| 3.2.2 Interrupt Edge Select Register 2 (IEGR2)..... | 52 |
| 3.2.3 Interrupt Enable Register 1 (IENR1)..... | 53 |
| 3.2.4 Interrupt Flag Register 1 (IRR1)..... | 54 |

| | | |
|---|--|-----------|
| 3.2.5 | Wakeup Interrupt Flag Register (IWPR) | 55 |
| 3.3 | Reset Exception Handling..... | 56 |
| 3.4 | Interrupt Exception Handling | 57 |
| 3.4.1 | External Interrupts | 57 |
| 3.4.2 | Internal Interrupts | 58 |
| 3.4.3 | Interrupt Handling Sequence | 58 |
| 3.4.4 | Interrupt Response Time..... | 60 |
| 3.5 | Usage Notes..... | 62 |
| 3.5.1 | Interrupts after Reset..... | 62 |
| 3.5.2 | Notes on Stack Area Use | 62 |
| 3.5.3 | Notes on Rewriting Port Mode Registers | 62 |
| Section 4 Address Break | | 63 |
| 4.1 | Register Descriptions..... | 63 |
| 4.1.1 | Address Break Control Register (ABRKCR) | 64 |
| 4.1.2 | Address Break Status Register (ABRKSR) | 65 |
| 4.1.3 | Break Address Registers (BARH, BARL)..... | 66 |
| 4.1.4 | Break Data Registers (BDRH, BDRL) | 66 |
| 4.2 | Operation | 66 |
| Section 5 Clock Pulse Generators | | 69 |
| 5.1 | System Clock Generator | 70 |
| 5.1.1 | Connecting Crystal Resonator | 70 |
| 5.1.2 | Connecting Ceramic Resonator | 71 |
| 5.1.3 | External Clock Input Method | 71 |
| 5.2 | Subclock Generator..... | 72 |
| 5.2.1 | Connecting 32.768-kHz Crystal Resonator | 72 |
| 5.2.2 | Pin Connection when Not Using Subclock..... | 73 |
| 5.3 | Prescalers | 73 |
| 5.3.1 | Prescaler S | 73 |
| 5.3.2 | Prescaler W..... | 73 |
| 5.4 | Usage Notes..... | 74 |
| 5.4.1 | Note on Resonators..... | 74 |
| 5.4.2 | Notes on Board Design | 74 |
| Section 6 Power-Down Modes | | 75 |
| 6.1 | Register Descriptions..... | 75 |
| 6.1.1 | System Control Register 1 (SYSCR1)..... | 76 |
| 6.1.2 | System Control Register 2 (SYSCR2)..... | 78 |
| 6.1.3 | Module Standby Control Register 1 (MSTCR1) | 79 |

| | | |
|----------------------------------|---|------------|
| 6.2 | Mode Transitions and States of LSI..... | 80 |
| 6.2.1 | Sleep Mode | 83 |
| 6.2.2 | Standby Mode | 83 |
| 6.2.3 | Subsleep Mode..... | 83 |
| 6.2.4 | Subactive Mode | 84 |
| 6.3 | Operating Frequency in Active Mode..... | 84 |
| 6.4 | Direct Transition | 85 |
| 6.4.1 | Direct Transition from Active Mode to Subactive Mode | 85 |
| 6.4.2 | Direct Transition from Subactive Mode to Active Mode | 85 |
| 6.5 | Module Standby Function | 86 |
| Section 7 ROM | | 87 |
| 7.1 | Block Configuration..... | 87 |
| 7.2 | Register Descriptions | 88 |
| 7.2.1 | Flash Memory Control Register 1 (FLMCR1)..... | 89 |
| 7.2.2 | Flash Memory Control Register 2 (FLMCR2)..... | 90 |
| 7.2.3 | Erase Block Register 1 (EBR1) | 91 |
| 7.2.4 | Flash Memory Power Control Register (FLPWCR)..... | 92 |
| 7.2.5 | Flash Memory Enable Register (FENR)..... | 92 |
| 7.3 | On-Board Programming Modes | 93 |
| 7.3.1 | Boot Mode | 93 |
| 7.3.2 | Programming/Erasing in User Program Mode..... | 96 |
| 7.4 | Flash Memory Programming/Erasing | 98 |
| 7.4.1 | Program/Program-Verify | 98 |
| 7.4.2 | Erase/Erase-Verify | 100 |
| 7.4.3 | Interrupt Handling when Programming/Erasing Flash Memory..... | 101 |
| 7.5 | Program/Erase Protection | 103 |
| 7.5.1 | Hardware Protection | 103 |
| 7.5.2 | Software Protection..... | 103 |
| 7.5.3 | Error Protection..... | 103 |
| 7.6 | Programmer Mode | 104 |
| 7.7 | Power-Down States for Flash Memory | 104 |
| Section 8 RAM | | 107 |
| Section 9 I/O Ports | | 109 |
| 9.1 | Port 1..... | 109 |
| 9.1.1 | Port Mode Register 1 (PMR1) | 110 |
| 9.1.2 | Port Control Register 1 (PCR1)..... | 111 |
| 9.1.3 | Port Data Register 1 (PDR1)..... | 111 |

| | | |
|---------------------------------|--|------------|
| 9.1.4 | Port Pull-Up Control Register 1 (PUCR1)..... | 112 |
| 9.1.5 | Pin Functions | 112 |
| 9.2 | Port 2..... | 114 |
| 9.2.1 | Port Control Register 2 (PCR2)..... | 115 |
| 9.2.2 | Port Data Register 2 (PDR2) | 115 |
| 9.2.3 | Pin Functions | 116 |
| 9.3 | Port 5..... | 117 |
| 9.3.1 | Port Mode Register 5 (PMR5)..... | 118 |
| 9.3.2 | Port Control Register 5 (PCR5)..... | 119 |
| 9.3.3 | Port Data Register 5 (PDR5) | 119 |
| 9.3.4 | Port Pull-Up Control Register 5 (PUCR5)..... | 120 |
| 9.3.5 | Pin Functions | 120 |
| 9.4 | Port 7..... | 123 |
| 9.4.1 | Port Control Register 7 (PCR7)..... | 124 |
| 9.4.2 | Port Data Register 7 (PDR7) | 124 |
| 9.4.3 | Pin Functions | 125 |
| 9.5 | Port 8..... | 126 |
| 9.5.1 | Port Control Register 8 (PCR8)..... | 126 |
| 9.5.2 | Port Data Register 8 (PDR8) | 127 |
| 9.5.3 | Pin Functions | 127 |
| 9.6 | Port B..... | 130 |
| 9.6.1 | Port Data Register B (PDRB) | 130 |
| Section 10 Timer A | | 131 |
| 10.1 | Features..... | 131 |
| 10.2 | Input/Output Pins..... | 132 |
| 10.3 | Register Descriptions..... | 133 |
| 10.3.1 | Timer Mode Register A (TMA)..... | 133 |
| 10.3.2 | Timer Counter A (TCA) | 134 |
| 10.4 | Operation | 135 |
| 10.4.1 | Interval Timer Operation | 135 |
| 10.4.2 | Clock Time Base Operation..... | 135 |
| 10.4.3 | Clock Output..... | 135 |
| 10.5 | Usage Note..... | 135 |
| Section 11 Timer V | | 137 |
| 11.1 | Features..... | 137 |
| 11.2 | Input/Output Pins..... | 138 |
| 11.3 | Register Descriptions..... | 139 |
| 11.3.1 | Timer Counter V (TCNTV)..... | 139 |

| | | |
|----------------------------------|---|------------|
| 11.3.2 | Time Constant Registers A and B (TCORA, TCORB) | 139 |
| 11.3.3 | Timer Control Register V0 (TCRV0) | 140 |
| 11.3.4 | Timer Control/Status Register V (TCSRV) | 142 |
| 11.3.5 | Timer Control Register V1 (TCRV1) | 143 |
| 11.4 | Operation | 144 |
| 11.4.1 | Timer V Operation | 144 |
| 11.5 | Timer V Application Examples | 148 |
| 11.5.1 | Pulse Output with Arbitrary Duty Cycle | 148 |
| 11.5.2 | Pulse Output with Arbitrary Pulse Width and Delay from TRGV Input | 149 |
| 11.6 | Usage Notes | 150 |
| Section 12 Timer W | | 153 |
| 12.1 | Features | 153 |
| 12.2 | Input/Output Pins | 156 |
| 12.3 | Register Descriptions | 156 |
| 12.3.1 | Timer Mode Register W (TMRW) | 157 |
| 12.3.2 | Timer Control Register W (TCRW) | 158 |
| 12.3.3 | Timer Interrupt Enable Register W (TIERW) | 159 |
| 12.3.4 | Timer Status Register W (TSRW) | 160 |
| 12.3.5 | Timer I/O Control Register 0 (TIOR0) | 161 |
| 12.3.6 | Timer I/O Control Register 1 (TIOR1) | 163 |
| 12.3.7 | Timer Counter (TCNT) | 164 |
| 12.3.8 | General Registers A to D (GRA to GRD) | 164 |
| 12.4 | Operation | 165 |
| 12.4.1 | Normal Operation | 165 |
| 12.4.2 | PWM Operation | 169 |
| 12.5 | Operation Timing | 174 |
| 12.5.1 | TCNT Count Timing | 174 |
| 12.5.2 | Output Compare Output Timing | 174 |
| 12.5.3 | Input Capture Timing | 175 |
| 12.5.4 | Timing of Counter Clearing by Compare Match | 176 |
| 12.5.5 | Buffer Operation Timing | 176 |
| 12.5.6 | Timing of IMFA to IMFD Flag Setting at Compare Match | 177 |
| 12.5.7 | Timing of IMFA to IMFD Setting at Input Capture | 178 |
| 12.5.8 | Timing of Status Flag Clearing | 178 |
| 12.6 | Usage Notes | 179 |
| Section 13 Watchdog Timer | | 183 |
| 13.1 | Features | 183 |
| 13.2 | Register Descriptions | 184 |

| | | |
|--|--|------------|
| 13.2.1 | Timer Control/Status Register WD (TCSRWD) | 184 |
| 13.2.2 | Timer Counter WD (TCWD)..... | 185 |
| 13.2.3 | Timer Mode Register WD (TMWD) | 186 |
| 13.3 | Operation | 187 |
| Section 14 Serial Communication Interface 3 (SCI3)..... | | 189 |
| 14.1 | Features..... | 189 |
| 14.2 | Input/Output Pins..... | 191 |
| 14.3 | Register Descriptions..... | 191 |
| 14.3.1 | Receive Shift Register (RSR) | 192 |
| 14.3.2 | Receive Data Register (RDR)..... | 192 |
| 14.3.3 | Transmit Shift Register (TSR)..... | 192 |
| 14.3.4 | Transmit Data Register (TDR)..... | 192 |
| 14.3.5 | Serial Mode Register (SMR) | 193 |
| 14.3.6 | Serial Control Register 3 (SCR3) | 194 |
| 14.3.7 | Serial Status Register (SSR) | 196 |
| 14.3.8 | Bit Rate Register (BRR) | 198 |
| 14.4 | Operation in Asynchronous Mode | 205 |
| 14.4.1 | Clock..... | 205 |
| 14.4.2 | SCI3 Initialization..... | 206 |
| 14.4.3 | Data Transmission | 207 |
| 14.4.4 | Serial Data Reception | 209 |
| 14.5 | Operation in Clocked Synchronous Mode | 213 |
| 14.5.1 | Clock..... | 213 |
| 14.5.2 | SCI3 Initialization..... | 213 |
| 14.5.3 | Serial Data Transmission..... | 214 |
| 14.5.4 | Serial Data Reception (Clocked Synchronous Mode) | 217 |
| 14.5.5 | Simultaneous Serial Data Transmission and Reception..... | 219 |
| 14.6 | Multiprocessor Communication Function..... | 221 |
| 14.6.1 | Multiprocessor Serial Data Transmission | 222 |
| 14.6.2 | Multiprocessor Serial Data Reception | 224 |
| 14.7 | Interrupts..... | 228 |
| 14.8 | Usage Notes..... | 229 |
| 14.8.1 | Break Detection and Processing | 229 |
| 14.8.2 | Mark State and Break Sending | 229 |
| 14.8.3 | Receive Error Flags and Transmit Operations (Clocked Synchronous Mode Only) | 229 |
| 14.8.4 | Receive Data Sampling Timing and Reception Margin in Asynchronous Mode..... | 230 |

| | | |
|------------|---|-----|
| Section 15 | I ² C Bus Interface 2 (IIC2) | 231 |
| 15.1 | Features | 231 |
| 15.2 | Input/Output Pins | 233 |
| 15.3 | Register Descriptions | 233 |
| 15.3.1 | I ² C Bus Control Register 1 (ICCR1) | 234 |
| 15.3.2 | I ² C Bus Control Register 2 (ICCR2) | 236 |
| 15.3.3 | I ² C Bus Mode Register (ICMR) | 237 |
| 15.3.4 | I ² C Bus Interrupt Enable Register (ICIER) | 239 |
| 15.3.5 | I ² C Bus Status Register (ICSR) | 241 |
| 15.3.6 | Slave Address Register (SAR) | 244 |
| 15.3.7 | I ² C Bus Transmit Data Register (ICDRT) | 245 |
| 15.3.8 | I ² C Bus Receive Data Register (ICDRR) | 245 |
| 15.3.9 | I ² C Bus Shift Register (ICDRS) | 245 |
| 15.4 | Operation | 246 |
| 15.4.1 | I ² C Bus Format | 246 |
| 15.4.2 | Master Transmit Operation | 247 |
| 15.4.3 | Master Receive Operation | 249 |
| 15.4.4 | Slave Transmit Operation | 251 |
| 15.4.5 | Slave Receive Operation | 253 |
| 15.4.6 | Clocked Synchronous Serial Format | 255 |
| 15.4.7 | Noise Canceler | 257 |
| 15.4.8 | Example of Use | 258 |
| 15.5 | Interrupt Request | 262 |
| 15.6 | Bit Synchronous Circuit | 263 |
| 15.7 | Usage Notes | 264 |
| 15.7.1 | Issue (Retransmission) of Start/Stop Conditions | 264 |
| 15.7.2 | WAIT Setting in I ² C Bus Mode Register (ICMR) | 264 |
| Section 16 | A/D Converter | 265 |
| 16.1 | Features | 265 |
| 16.2 | Input/Output Pins | 267 |
| 16.3 | Register Descriptions | 268 |
| 16.3.1 | A/D Data Registers A to D (ADDRA to ADDR D) | 268 |
| 16.3.2 | A/D Control/Status Register (ADCSR) | 269 |
| 16.3.3 | A/D Control Register (ADCR) | 270 |
| 16.4 | Operation | 271 |
| 16.4.1 | Single Mode | 271 |
| 16.4.2 | Scan Mode | 271 |
| 16.4.3 | Input Sampling and A/D Conversion Time | 272 |
| 16.4.4 | External Trigger Input Timing | 273 |

| | | |
|-------------------|--|------------|
| 16.5 | A/D Conversion Accuracy Definitions | 274 |
| 16.6 | Usage Notes | 276 |
| 16.6.1 | Permissible Signal Source Impedance | 276 |
| 16.6.2 | Influences on Absolute Accuracy | 276 |
| Section 17 | EEPROM | 277 |
| 17.1 | Features | 277 |
| 17.2 | Input/Output Pins | 279 |
| 17.3 | Register Description | 279 |
| 17.3.1 | EEPROM Key Register (EKR) | 279 |
| 17.4 | Operation | 280 |
| 17.4.1 | EEPROM Interface | 280 |
| 17.4.2 | Bus Format and Timing | 280 |
| 17.4.3 | Start Condition | 280 |
| 17.4.4 | Stop Condition | 281 |
| 17.4.5 | Acknowledge | 281 |
| 17.4.6 | Slave Addressing | 281 |
| 17.4.7 | Write Operations | 283 |
| 17.4.8 | Acknowledge Polling | 284 |
| 17.4.9 | Read Operation | 285 |
| 17.5 | Usage Notes | 288 |
| 17.5.1 | Data Protection at V_{CC} On/Off | 288 |
| 17.5.2 | Write/Erase Endurance | 288 |
| 17.5.3 | Noise Suppression Time | 288 |
| Section 18 | Power-On Reset and Low-Voltage Detection Circuits (Optional) .. | 289 |
| 18.1 | Features | 289 |
| 18.2 | Register Descriptions | 290 |
| 18.2.1 | Low-Voltage-Detection Control Register (LVDCR) | 290 |
| 18.2.2 | Low-Voltage-Detection Status Register (LVDSR) | 292 |
| 18.3 | Operation | 293 |
| 18.3.1 | Power-On Reset Circuit | 293 |
| 18.3.2 | Low-Voltage Detection Circuit | 294 |
| Section 19 | Power Supply Circuit | 299 |
| 19.1 | When Using Internal Power Supply Step-Down Circuit | 299 |
| 19.2 | When Not Using Internal Power Supply Step-Down Circuit | 300 |
| Section 20 | List of Registers | 301 |
| 20.1 | Register Addresses (Address Order) | 302 |

| | | |
|--|--|------------|
| 20.2 | Register Bits..... | 307 |
| 20.3 | Registers States in Each Operating Mode..... | 311 |
| Section 21 Electrical Characteristics | | 315 |
| 21.1 | Absolute Maximum Ratings | 315 |
| 21.2 | Electrical Characteristics (F-ZTAT™ Version, EEPROM Stacked F-ZTAT™ Version)..... | 315 |
| 21.2.1 | Power Supply Voltage and Operating Ranges | 315 |
| 21.2.2 | DC Characteristics | 318 |
| 21.2.3 | AC Characteristics | 324 |
| 21.2.4 | A/D Converter Characteristics | 328 |
| 21.2.5 | Watchdog Timer Characteristics..... | 329 |
| 21.2.6 | Flash Memory Characteristics | 330 |
| 21.2.7 | EEPROM Characteristics..... | 332 |
| 21.2.8 | Power-Supply-Voltage Detection Circuit Characteristics (Optional) | 333 |
| 21.2.9 | Power-On Reset Circuit Characteristics (Optional)..... | 334 |
| 21.3 | Electrical Characteristics (Mask-ROM Version, EEPROM Stacked Mask-ROM Version)..... | 334 |
| 21.3.1 | Power Supply Voltage and Operating Ranges | 334 |
| 21.3.2 | DC Characteristics | 337 |
| 21.3.3 | AC Characteristics | 343 |
| 21.3.4 | A/D Converter Characteristics | 347 |
| 21.3.5 | Watchdog Timer Characteristics..... | 348 |
| 21.3.6 | EEPROM Characteristics..... | 349 |
| 21.3.7 | Power-Supply-Voltage Detection Circuit Characteristics (Optional) | 350 |
| 21.3.8 | Power-On Reset Circuit Characteristics (Optional)..... | 351 |
| 21.4 | Operation Timing..... | 351 |
| 21.5 | Output Load Condition | 354 |
| Appendix A Instruction Set | | 355 |
| A.1 | Instruction List..... | 355 |
| A.2 | Operation Code Map..... | 370 |
| A.3 | Number of Execution States | 373 |
| A.4 | Combinations of Instructions and Addressing Modes | 384 |
| Appendix B I/O Port Block Diagrams | | 385 |
| B.1 | I/O Port Block Diagrams..... | 385 |
| B.2 | Port States in Each Operating State | 401 |
| Appendix C Product Code Lineup..... | | 402 |

| | |
|--|-----|
| Appendix D Package Dimensions | 405 |
| Appendix E EEPROM Stacked-Structure Cross-Sectional View | 410 |
| Main Revisions and Additions in this Edition..... | 411 |
| Index | 415 |

Figures

Section 1 Overview

| | | |
|------------|--|---|
| Figure 1.1 | Internal Block Diagram of H8/3694 Group of F-ZTAT™ and Mask-ROM Versions | 4 |
| Figure 1.2 | Internal Block Diagram of H8/3694N (EEPROM Stacked Version) | 5 |
| Figure 1.3 | Pin Arrangement of H8/3694 Group of F-ZTAT™ and Mask-ROM Versions (FP-64E, FP-64A) | 6 |
| Figure 1.4 | Pin Arrangement of H8/3694 Group of F-ZTAT™ and Mask-ROM Versions (FP-48F, FP-48B, TNP-48) | 7 |
| Figure 1.5 | Pin Arrangement of H8/3694N (EEPROM Stacked Version) (FP-64E) | 8 |

Section 2 CPU

| | | |
|-------------|---|----|
| Figure 2.1 | Memory Map (1) | 14 |
| Figure 2.1 | Memory Map (2) | 15 |
| Figure 2.1 | Memory Map (3) | 16 |
| Figure 2.2 | CPU Registers | 17 |
| Figure 2.3 | Usage of General Registers | 18 |
| Figure 2.4 | Relationship between Stack Pointer and Stack Area | 19 |
| Figure 2.5 | General Register Data Formats (1) | 21 |
| Figure 2.5 | General Register Data Formats (2) | 22 |
| Figure 2.6 | Memory Data Formats | 23 |
| Figure 2.7 | Instruction Formats | 34 |
| Figure 2.8 | Branch Address Specification in Memory Indirect Mode | 37 |
| Figure 2.9 | On-Chip Memory Access Cycle | 40 |
| Figure 2.10 | On-Chip Peripheral Module Access Cycle (3-State Access) | 41 |
| Figure 2.11 | CPU Operation States | 42 |
| Figure 2.12 | State Transitions | 43 |
| Figure 2.13 | Example of Timer Configuration with Two Registers Allocated to Same Address | 44 |

Section 3 Exception Handling

| | | |
|------------|--|----|
| Figure 3.1 | Reset Sequence | 58 |
| Figure 3.2 | Stack Status after Exception Handling | 60 |
| Figure 3.3 | Interrupt Sequence | 61 |
| Figure 3.4 | Port Mode Register Setting and Interrupt Request Flag Clearing Procedure | 62 |

Section 4 Address Break

| | | |
|------------|---|----|
| Figure 4.1 | Block Diagram of Address Break | 63 |
| Figure 4.2 | Address Break Interrupt Operation Example (1) | 67 |
| Figure 4.2 | Address Break Interrupt Operation Example (2) | 67 |

Section 5 Clock Pulse Generators

| | | |
|-------------|---|----|
| Figure 5.1 | Block Diagram of Clock Pulse Generators..... | 69 |
| Figure 5.2 | Block Diagram of System Clock Generator..... | 70 |
| Figure 5.3 | Typical Connection to Crystal Resonator..... | 70 |
| Figure 5.4 | Equivalent Circuit of Crystal Resonator..... | 70 |
| Figure 5.5 | Typical Connection to Ceramic Resonator..... | 71 |
| Figure 5.6 | Example of External Clock Input..... | 71 |
| Figure 5.7 | Block Diagram of Subclock Generator..... | 72 |
| Figure 5.8 | Typical Connection to 32.768-kHz Crystal Resonator..... | 72 |
| Figure 5.9 | Equivalent Circuit of 32.768-kHz Crystal Resonator..... | 72 |
| Figure 5.10 | Pin Connection when not Using Subclock..... | 73 |
| Figure 5.11 | Example of Incorrect Board Design..... | 74 |

Section 6 Power-Down Modes

| | | |
|------------|------------------------------|----|
| Figure 6.1 | Mode Transition Diagram..... | 80 |
|------------|------------------------------|----|

Section 7 ROM

| | | |
|------------|---|-----|
| Figure 7.1 | Flash Memory Block Configuration..... | 88 |
| Figure 7.2 | Programming/Erasing Flowchart Example in User Program Mode..... | 97 |
| Figure 7.3 | Program/Program-Verify Flowchart..... | 99 |
| Figure 7.4 | Erase/Erase-Verify Flowchart..... | 102 |

Section 9 I/O Ports

| | | |
|------------|-------------------------------|-----|
| Figure 9.1 | Port 1 Pin Configuration..... | 109 |
| Figure 9.2 | Port 2 Pin Configuration..... | 114 |
| Figure 9.3 | Port 5 Pin Configuration..... | 117 |
| Figure 9.4 | Port 7 Pin Configuration..... | 123 |
| Figure 9.5 | Port 8 Pin Configuration..... | 126 |
| Figure 9.6 | Port B Pin Configuration..... | 130 |

Section 10 Timer A

| | | |
|-------------|-------------------------------|-----|
| Figure 10.1 | Block Diagram of Timer A..... | 132 |
|-------------|-------------------------------|-----|

Section 11 Timer V

| | | |
|-------------|---|-----|
| Figure 11.1 | Block Diagram of Timer V..... | 138 |
| Figure 11.2 | Increment Timing with Internal Clock..... | 145 |
| Figure 11.3 | Increment Timing with External Clock..... | 145 |
| Figure 11.4 | OVF Set Timing..... | 145 |
| Figure 11.5 | CMFA and CMFB Set Timing..... | 146 |
| Figure 11.6 | TMOV Output Timing..... | 146 |
| Figure 11.7 | Clear Timing by Compare Match..... | 146 |
| Figure 11.8 | Clear Timing by TMRIV Input..... | 147 |

| | | |
|--------------|---|-----|
| Figure 11.9 | Pulse Output Example | 148 |
| Figure 11.10 | Example of Pulse Output Synchronized to TRGV Input..... | 149 |
| Figure 11.11 | Contention between TCNTV Write and Clear | 150 |
| Figure 11.12 | Contention between TCORA Write and Compare Match | 151 |
| Figure 11.13 | Internal Clock Switching and TCNTV Operation | 151 |

Section 12 Timer W

| | | |
|--------------|---|-----|
| Figure 12.1 | Timer W Block Diagram | 155 |
| Figure 12.2 | Free-Running Counter Operation | 166 |
| Figure 12.3 | Periodic Counter Operation | 166 |
| Figure 12.4 | 0 and 1 Output Example (TOA = 0, TOB = 1) | 167 |
| Figure 12.5 | Toggle Output Example (TOA = 0, TOB = 1) | 167 |
| Figure 12.6 | Toggle Output Example (TOA = 0, TOB = 1) | 167 |
| Figure 12.7 | Input Capture Operating Example | 168 |
| Figure 12.8 | Buffer Operation Example (Input Capture)..... | 169 |
| Figure 12.9 | PWM Mode Example (1) | 170 |
| Figure 12.10 | PWM Mode Example (2) | 170 |
| Figure 12.11 | Buffer Operation Example (Output Compare) | 171 |
| Figure 12.12 | PWM Mode Example (TOB, TOC, and TOD = 0: initial output values are set to 0) | 172 |
| Figure 12.13 | PWM Mode Example (TOB, TOC, and TOD = 1: initial output values are set to 1) | 173 |
| Figure 12.14 | Count Timing for Internal Clock Source | 174 |
| Figure 12.15 | Count Timing for External Clock Source..... | 174 |
| Figure 12.16 | Output Compare Output Timing | 175 |
| Figure 12.17 | Input Capture Input Signal Timing..... | 175 |
| Figure 12.18 | Timing of Counter Clearing by Compare Match..... | 176 |
| Figure 12.19 | Buffer Operation Timing (Compare Match)..... | 176 |
| Figure 12.20 | Buffer Operation Timing (Input Capture) | 177 |
| Figure 12.21 | Timing of IMFA to IMFD Flag Setting at Compare Match | 177 |
| Figure 12.22 | Timing of IMFA to IMFD Flag Setting at Input Capture..... | 178 |
| Figure 12.23 | Timing of Status Flag Clearing by CPU..... | 178 |
| Figure 12.24 | Contention between TCNT Write and Clear | 179 |
| Figure 12.25 | Internal Clock Switching and TCNT Operation | 180 |
| Figure 12.26 | When Compare Match and Bit Manipulation Instruction to TCRW Occur at the Same Timing | 181 |

Section 13 Watchdog Timer

| | | |
|-------------|--|-----|
| Figure 13.1 | Block Diagram of Watchdog Timer | 183 |
| Figure 13.2 | Watchdog Timer Operation Example | 187 |

Section 14 Serial Communication Interface 3 (SCI3)

| | | |
|--------------|---|-----|
| Figure 14.1 | Block Diagram of SCI3 | 190 |
| Figure 14.2 | Data Format in Asynchronous Communication | 205 |
| Figure 14.3 | Relationship between Output Clock and Transfer Data Phase (Asynchronous Mode) (Example with 8-Bit Data, Parity, Two Stop Bits) | 205 |
| Figure 14.4 | Sample SCI3 Initialization Flowchart | 206 |
| Figure 14.5 | Example SCI3 Operation in Transmission in Asynchronous Mode (8-Bit Data, Parity, One Stop Bit) | 207 |
| Figure 14.6 | Sample Serial Transmission Flowchart (Asynchronous Mode) | 208 |
| Figure 14.7 | Example SCI3 Operation in Reception in Asynchronous Mode (8-Bit Data, Parity, One Stop Bit) | 209 |
| Figure 14.8 | Sample Serial Data Reception Flowchart (Asynchronous mode) (1)..... | 211 |
| Figure 14.8 | Sample Serial Reception Data Flowchart (2) | 212 |
| Figure 14.9 | Data Format in Clocked Synchronous Communication | 213 |
| Figure 14.10 | Example of SCI3 Operation in Transmission in Clocked Synchronous Mode..... | 215 |
| Figure 14.11 | Sample Serial Transmission Flowchart (Clocked Synchronous Mode) | 216 |
| Figure 14.12 | Example of SCI3 Reception Operation in Clocked Synchronous Mode..... | 217 |
| Figure 14.13 | Sample Serial Reception Flowchart (Clocked Synchronous Mode)..... | 218 |
| Figure 14.14 | Sample Flowchart of Simultaneous Serial Transmit and Receive Operations (Clocked Synchronous Mode) | 220 |
| Figure 14.15 | Example of Communication Using Multiprocessor Format (Transmission of Data H'AA to Receiving Station A) | 222 |
| Figure 14.16 | Sample Multiprocessor Serial Transmission Flowchart | 223 |
| Figure 14.17 | Sample Multiprocessor Serial Reception Flowchart (1)..... | 225 |
| Figure 14.17 | Sample Multiprocessor Serial Reception Flowchart (2)..... | 226 |
| Figure 14.18 | Example of SCI3 Operation in Reception Using Multiprocessor Format (Example with 8-Bit Data, Multiprocessor Bit, One Stop Bit) | 227 |
| Figure 14.19 | Receive Data Sampling Timing in Asynchronous Mode | 230 |

Section 15 I²C Bus Interface 2 (IIC2)

| | | |
|--------------|--|-----|
| Figure 15.1 | Block Diagram of I ² C Bus Interface 2..... | 232 |
| Figure 15.2 | External Circuit Connections of I/O Pins | 233 |
| Figure 15.3 | I ² C Bus Formats | 246 |
| Figure 15.4 | I ² C Bus Timing..... | 246 |
| Figure 15.5 | Master Transmit Mode Operation Timing (1)..... | 248 |
| Figure 15.6 | Master Transmit Mode Operation Timing (2)..... | 248 |
| Figure 15.7 | Master Receive Mode Operation Timing (1) | 250 |
| Figure 15.8 | Master Receive Mode Operation Timing (2) | 251 |
| Figure 15.9 | Slave Transmit Mode Operation Timing (1)..... | 252 |
| Figure 15.10 | Slave Transmit Mode Operation Timing (2)..... | 253 |

| | | |
|--|---|-----|
| Figure 15.11 | Slave Receive Mode Operation Timing (1)..... | 254 |
| Figure 15.12 | Slave Receive Mode Operation Timing (2)..... | 254 |
| Figure 15.13 | Clocked Synchronous Serial Transfer Format..... | 255 |
| Figure 15.14 | Transmit Mode Operation Timing..... | 256 |
| Figure 15.15 | Receive Mode Operation Timing..... | 257 |
| Figure 15.16 | Block Diagram of Noise Canceler..... | 257 |
| Figure 15.17 | Sample Flowchart for Master Transmit Mode..... | 258 |
| Figure 15.18 | Sample Flowchart for Master Receive Mode..... | 259 |
| Figure 15.19 | Sample Flowchart for Slave Transmit Mode..... | 260 |
| Figure 15.20 | Sample Flowchart for Slave Receive Mode..... | 261 |
| Figure 15.21 | The Timing of the Bit Synchronous Circuit..... | 263 |
| Section 16 A/D Converter | | |
| Figure 16.1 | Block Diagram of A/D Converter..... | 266 |
| Figure 16.2 | A/D Conversion Timing..... | 272 |
| Figure 16.3 | External Trigger Input Timing..... | 273 |
| Figure 16.4 | A/D Conversion Accuracy Definitions (1)..... | 275 |
| Figure 16.5 | A/D Conversion Accuracy Definitions (2)..... | 275 |
| Figure 16.6 | Analog Input Circuit Example..... | 276 |
| Section 17 EEPROM | | |
| Figure 17.1 | Block Diagram of EEPROM..... | 278 |
| Figure 17.2 | EEPROM Bus Format and Bus Timing..... | 280 |
| Figure 17.3 | Byte Write Operation..... | 283 |
| Figure 17.4 | Page Write Operation..... | 284 |
| Figure 17.5 | Current Address Read Operation..... | 285 |
| Figure 17.6 | Random Address Read Operation..... | 286 |
| Figure 17.7 | Sequential Read Operation (when current address read is used)..... | 287 |
| Section 18 Power-On Reset and Low-Voltage Detection Circuits (Optional) | | |
| Figure 18.1 | Block Diagram of Power-On Reset Circuit and Low-Voltage Detection Circuit.... | 290 |
| Figure 18.2 | Operational Timing of Power-On Reset Circuit..... | 294 |
| Figure 18.3 | Operational Timing of LVDR Circuit..... | 295 |
| Figure 18.4 | Operational Timing of LVDI Circuit..... | 296 |
| Figure 18.5 | Timing for Operation/Release of Low-Voltage Detection Circuit..... | 297 |
| Section 19 Power Supply Circuit | | |
| Figure 19.1 | Power Supply Connection when Internal Step-Down Circuit is Used..... | 299 |
| Figure 19.2 | Power Supply Connection when Internal Step-Down Circuit is Not Used..... | 300 |
| Section 21 Electrical Characteristics | | |
| Figure 21.1 | System Clock Input Timing..... | 351 |
| Figure 21.2 | $\overline{\text{RES}}$ Low Width Timing..... | 352 |

| | | |
|-------------|--|-----|
| Figure 21.3 | Input Timing..... | 352 |
| Figure 21.4 | I ² C Bus Interface Input/Output Timing..... | 352 |
| Figure 21.5 | SCK3 Input Clock Timing..... | 353 |
| Figure 21.6 | SCI Input/Output Timing in Clocked Synchronous Mode..... | 353 |
| Figure 21.7 | EEPROM Bus Timing..... | 354 |
| Figure 21.8 | Output Load Circuit..... | 354 |

Appendix B I/O Port Block Diagrams

| | | |
|-------------|--|-----|
| Figure B.1 | Port 1 Block Diagram (P17)..... | 385 |
| Figure B.2 | Port 1 Block Diagram (P16 to P14)..... | 386 |
| Figure B.3 | Port 1 Block Diagram (P12, P11)..... | 387 |
| Figure B.4 | Port 1 Block Diagram (P10)..... | 388 |
| Figure B.5 | Port 2 Block Diagram (P22)..... | 389 |
| Figure B.6 | Port 2 Block Diagram (P21)..... | 390 |
| Figure B.7 | Port 2 Block Diagram (P20)..... | 391 |
| Figure B.8 | Port 5 Block Diagram (P57, P56)..... | 392 |
| Figure B.9 | Port 5 Block Diagram (P55)..... | 393 |
| Figure B.10 | Port 5 Block Diagram (P54 to P50)..... | 394 |
| Figure B.11 | Port 7 Block Diagram (P76)..... | 395 |
| Figure B.12 | Port 7 Block Diagram (P75)..... | 396 |
| Figure B.13 | Port 7 Block Diagram (P74)..... | 397 |
| Figure B.14 | Port 8 Block Diagram (P87 to P85)..... | 398 |
| Figure B.15 | Port 8 Block Diagram (P84 to P81)..... | 399 |
| Figure B.16 | Port 8 Block Diagram (P80)..... | 400 |
| Figure B.17 | Port B Block Diagram (PB7 to PB0)..... | 401 |

Appendix D Package Dimensions

| | | |
|------------|--------------------------------|-----|
| Figure D.1 | FP-64E Package Dimensions..... | 405 |
| Figure D.2 | FP-64A Package Dimensions..... | 406 |
| Figure D.3 | FP-48F Package Dimensions..... | 407 |
| Figure D.4 | FP-48B Package Dimensions..... | 408 |
| Figure D.5 | TNP-48 Package Dimensions..... | 409 |

Appendix E EEPROM Stacked-Structure Cross-Sectional View

| | | |
|------------|--|-----|
| Figure E.1 | EEPROM Stacked-Structure Cross-Sectional View..... | 410 |
|------------|--|-----|

Tables

Section 1 Overview

| | | |
|-----------|---------------------|---|
| Table 1.1 | Pin Functions | 9 |
|-----------|---------------------|---|

Section 2 CPU

| | | |
|------------|--|----|
| Table 2.1 | Operation Notation | 24 |
| Table 2.2 | Data Transfer Instructions..... | 25 |
| Table 2.3 | Arithmetic Operations Instructions (1) | 26 |
| Table 2.3 | Arithmetic Operations Instructions (2) | 27 |
| Table 2.4 | Logic Operations Instructions..... | 28 |
| Table 2.5 | Shift Instructions..... | 28 |
| Table 2.6 | Bit Manipulation Instructions (1)..... | 29 |
| Table 2.6 | Bit Manipulation Instructions (2)..... | 30 |
| Table 2.7 | Branch Instructions | 31 |
| Table 2.8 | System Control Instructions..... | 32 |
| Table 2.9 | Block Data Transfer Instructions | 33 |
| Table 2.10 | Addressing Modes | 35 |
| Table 2.11 | Absolute Address Access Ranges..... | 36 |
| Table 2.12 | Effective Address Calculation (1)..... | 38 |
| Table 2.12 | Effective Address Calculation (2)..... | 39 |

Section 3 Exception Handling

| | | |
|-----------|---|----|
| Table 3.1 | Exception Sources and Vector Address..... | 49 |
| Table 3.2 | Interrupt Wait States | 60 |

Section 4 Address Break

| | | |
|-----------|--------------------------------|----|
| Table 4.1 | Access and Data Bus Used | 65 |
|-----------|--------------------------------|----|

Section 5 Clock Pulse Generators

| | | |
|-----------|------------------------------------|----|
| Table 5.1 | Crystal Resonator Parameters | 71 |
|-----------|------------------------------------|----|

Section 6 Power-Down Modes

| | | |
|-----------|--|----|
| Table 6.1 | Operating Frequency and Waiting Time..... | 77 |
| Table 6.2 | Transition Mode after SLEEP Instruction Execution and Interrupt Handling | 81 |
| Table 6.3 | Internal State in Each Operating Mode..... | 82 |

Section 7 ROM

| | | |
|-----------|--|-----|
| Table 7.1 | Setting Programming Modes | 93 |
| Table 7.2 | Boot Mode Operation | 95 |
| Table 7.3 | System Clock Frequencies for which Automatic Adjustment of LSI Bit Rate is Possible | 96 |
| Table 7.4 | Reprogram Data Computation Table..... | 100 |

| | | |
|---|---|-----|
| Table 7.5 | Additional-Program Data Computation Table | 100 |
| Table 7.6 | Programming Time | 100 |
| Table 7.7 | Flash Memory Operating States..... | 105 |
| Section 10 Timer A | | |
| Table 10.1 | Pin Configuration..... | 132 |
| Section 11 Timer V | | |
| Table 11.1 | Pin Configuration..... | 138 |
| Table 11.2 | Clock Signals to Input to TCNTV and Counting Conditions | 141 |
| Section 12 Timer W | | |
| Table 12.1 | Timer W Functions | 154 |
| Table 12.2 | Pin Configuration..... | 156 |
| Section 14 Serial Communication Interface 3 (SCI3) | | |
| Table 14.1 | Pin Configuration..... | 191 |
| Table 14.2 | Examples of BRR Settings for Various Bit Rates (Asynchronous Mode) (1) | 199 |
| Table 14.2 | Examples of BRR Settings for Various Bit Rates (Asynchronous Mode) (2) | 200 |
| Table 14.2 | Examples of BRR Settings for Various Bit Rates (Asynchronous Mode) (3) | 201 |
| Table 14.3 | Maximum Bit Rate for Each Frequency (Asynchronous Mode) | 202 |
| Table 14.4 | Examples of BBR Setting for Various Bit Rates (Clocked Synchronous Mode) (1)..... | 203 |
| Table 14.4 | Examples of BRR Settings for Various Bit Rates (Clocked Synchronous Mode) (2)..... | 204 |
| Table 14.5 | SSR Status Flags and Receive Data Handling | 210 |
| Table 14.6 | SCI3 Interrupt Requests..... | 228 |
| Section 15 I²C Bus Interface 2 (IIC2) | | |
| Table 15.1 | I ² C Bus Interface Pins..... | 233 |
| Table 15.2 | Transfer Rate | 235 |
| Table 15.3 | Interrupt Requests | 262 |
| Table 15.4 | Time for Monitoring SCL..... | 263 |
| Section 16 A/D Converter | | |
| Table 16.1 | Pin Configuration..... | 267 |
| Table 16.2 | Analog Input Channels and Corresponding ADDR Registers | 268 |
| Table 16.3 | A/D Conversion Time (Single Mode)..... | 273 |
| Section 17 EEPROM | | |
| Table 17.1 | Pin Configuration..... | 279 |
| Table 17.2 | Slave Addresses | 282 |

| | | |
|-------------------|---|-----|
| Section 18 | Power-On Reset and Low-Voltage Detection Circuits (Optional) | |
| Table 18.1 | LVDCR Settings and Select Functions | 292 |
| Section 21 | Electrical Characteristics | |
| Table 21.1 | Absolute Maximum Ratings | 315 |
| Table 21.2 | DC Characteristics (1)..... | 318 |
| Table 21.2 | DC Characteristics (2)..... | 322 |
| Table 21.2 | DC Characteristics (3)..... | 323 |
| Table 21.3 | AC Characteristics | 324 |
| Table 21.4 | I ² C Bus Interface Timing | 326 |
| Table 21.5 | Serial Communication Interface (SCI) Timing..... | 327 |
| Table 21.6 | A/D Converter Characteristics | 328 |
| Table 21.7 | Watchdog Timer Characteristics..... | 329 |
| Table 21.8 | Flash Memory Characteristics | 330 |
| Table 21.9 | EEPROM Characteristics..... | 332 |
| Table 21.10 | Power-Supply-Voltage Detection Circuit Characteristics..... | 333 |
| Table 21.11 | Power-On Reset Circuit Characteristics..... | 334 |
| Table 21.12 | DC Characteristics (1)..... | 337 |
| Table 21.12 | DC Characteristics (2)..... | 341 |
| Table 21.12 | DC Characteristics (3)..... | 342 |
| Table 21.13 | AC Characteristics | 343 |
| Table 21.14 | I ² C Bus Interface Timing | 345 |
| Table 21.15 | Serial Communication Interface (SCI) Timing..... | 346 |
| Table 21.16 | A/D Converter Characteristics | 347 |
| Table 21.17 | Watchdog Timer Characteristics..... | 348 |
| Table 21.18 | EEPROM Characteristics..... | 349 |
| Table 21.19 | Power-Supply-Voltage Detection Circuit Characteristics..... | 350 |
| Table 21.20 | Power-On Reset Circuit Characteristics..... | 351 |
| Appendix A | Instruction Set | |
| Table A.1 | Instruction Set..... | 357 |
| Table A.2 | Operation Code Map (1)..... | 370 |
| Table A.2 | Operation Code Map (2)..... | 371 |
| Table A.2 | Operation Code Map (3)..... | 372 |
| Table A.3 | Number of Cycles in Each Instruction..... | 374 |
| Table A.4 | Number of Cycles in Each Instruction..... | 375 |
| Table A.5 | Combinations of Instructions and Addressing Modes | 384 |

Section 1 Overview

1.1 Features

- High-speed H8/300H central processing unit with an internal 16-bit architecture
 - Upward-compatible with H8/300 CPU on an object level
 - Sixteen 16-bit general registers
 - 62 basic instructions
- Various peripheral functions
 - Timer A (can be used as a time base for a clock)
 - Timer V (8-bit timer)
 - Timer W (16-bit timer)
 - Watchdog timer
 - SCI (Asynchronous or clocked synchronous serial communication interface)
 - I²C Bus Interface (conforms to the I²C bus interface format that is advocated by Philips Electronics)
 - 10-bit A/D converter

- On-chip memory

| Product Classification | | Model | | ROM | RAM | Remarks |
|---|----------------------|------------------|--|------------|-------------|-------------|
| | | Standard Version | On-Chip Power-On Reset and Low-Voltage Detecting Circuit Version | | | |
| Flash memory version (F-ZTAT™ version) | H8/3694F | HD64F3694 | HD64F3694G | 32 kbytes | 2,048 bytes | |
| Mask ROM version | H8/3694 | HD6433694 | HD6433694G | 32 kbytes | 1,024 bytes | |
| | H8/3693 | HD6433693 | HD6433693G | 24 kbytes | 1,024 bytes | |
| | H8/3692 | HD6433692 | HD6433692G | 16 kbytes | 512 bytes | |
| | H8/3691 | HD6433691 | HD6433691G | 12 kbytes | 512 bytes | |
| | H8/3690 | HD6433690 | HD6433690G | 8 kbytes | 512 bytes | |
| EEPROM stacked memory version (512 bytes) | Flash memory version | H8/3694N | — | HD64N3694G | 32 kbytes | 2,048 bytes |
| | Mask-ROM version | — | — | HD6483694G | 32 kbytes | 1,024 bytes |

- General I/O ports
 - I/O pins: 29 I/O pins (27 I/O pins for H8/3694N), including 8 large current ports ($I_{OL} = 20$ mA, @ $V_{OL} = 1.5$ V)
 - Input-only pins: 8 input pins (also used for analog input)
- EEPROM interface (only for H8/3694N)
 - I²C bus interface (conforms to the I²C bus interface format that is advocated by Philips Electronics)
- Supports various power-down modes

Note: F-ZTAT™ is a trademark of Renesas Technology Corp.

- Compact package

| Package | Code | Body Size | Pin Pitch |
|----------------|-------------|------------------|------------------|
| LQFP-64 | FP-64E | 10.0 × 10.0 mm | 0.5 mm |
| QFP-64 | FP-64A | 14.0 × 14.0 mm | 0.8 mm |
| LQFP-48 | FP-48F | 10.0 × 10.0 mm | 0.65 mm |
| LQFP-48 | FP-48B | 7.0 × 7.0 mm | 0.5 mm |
| QFN-48 | TNP-48 | 7.0 × 7.0 mm | 0.5 mm |

Only LQFP-64 (FP-64E) for H8/3694N package

1.2 Internal Block Diagram

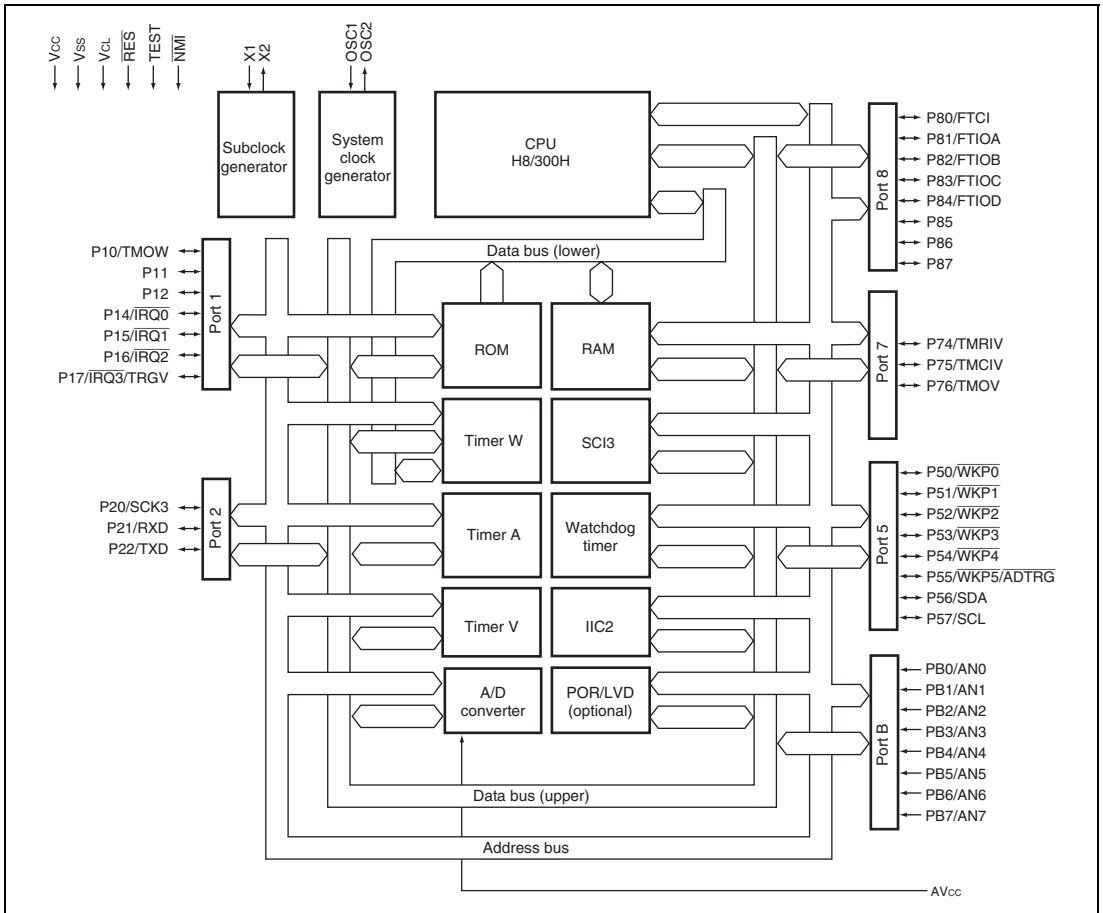

Figure 1.1 Internal Block Diagram of H8/3694 Group of F-ZTAT™ and Mask-ROM Versions

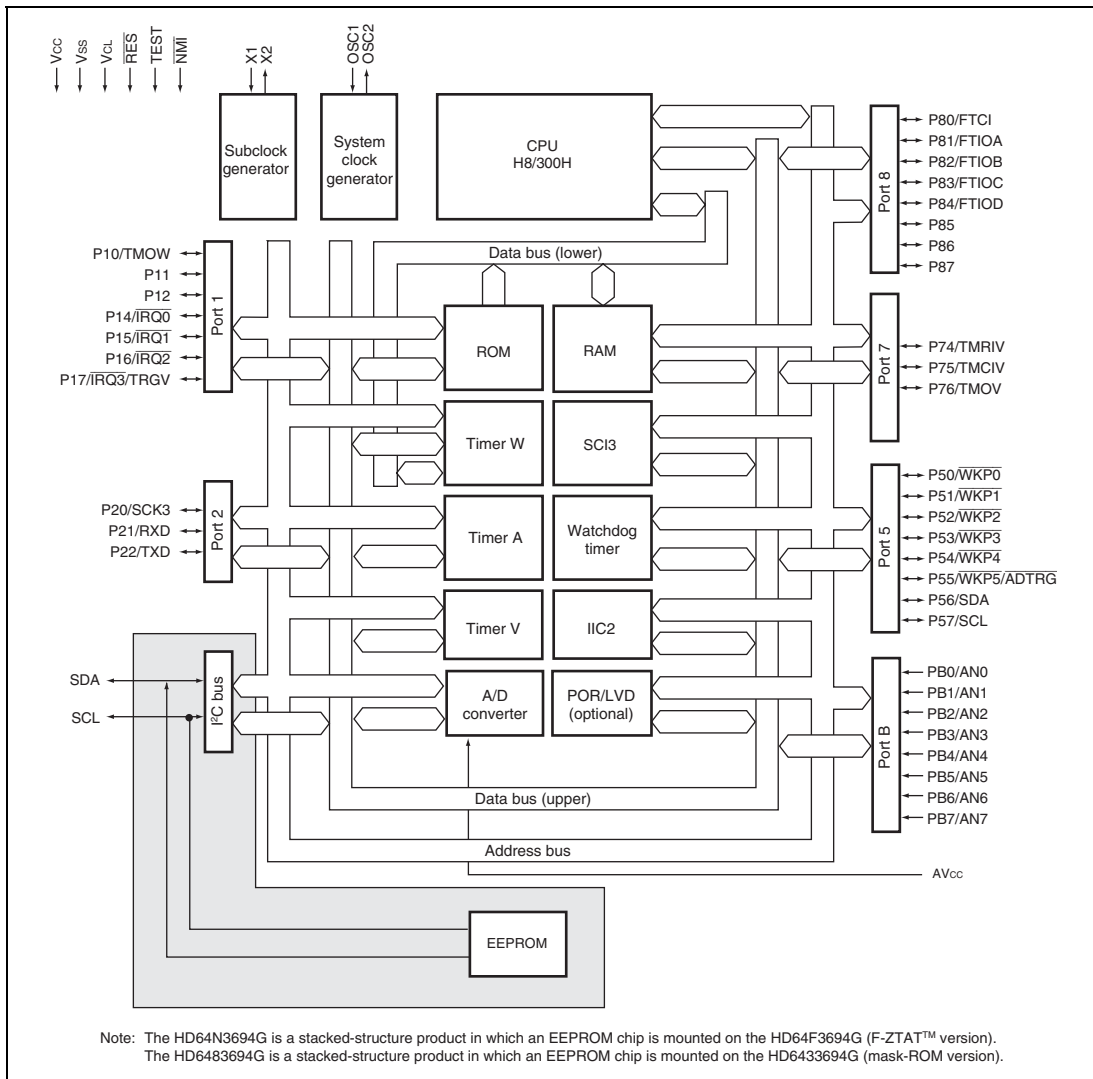

Figure 1.2 Internal Block Diagram of H8/3694N (EEPROM Stacked Version)

1.3 Pin Arrangement

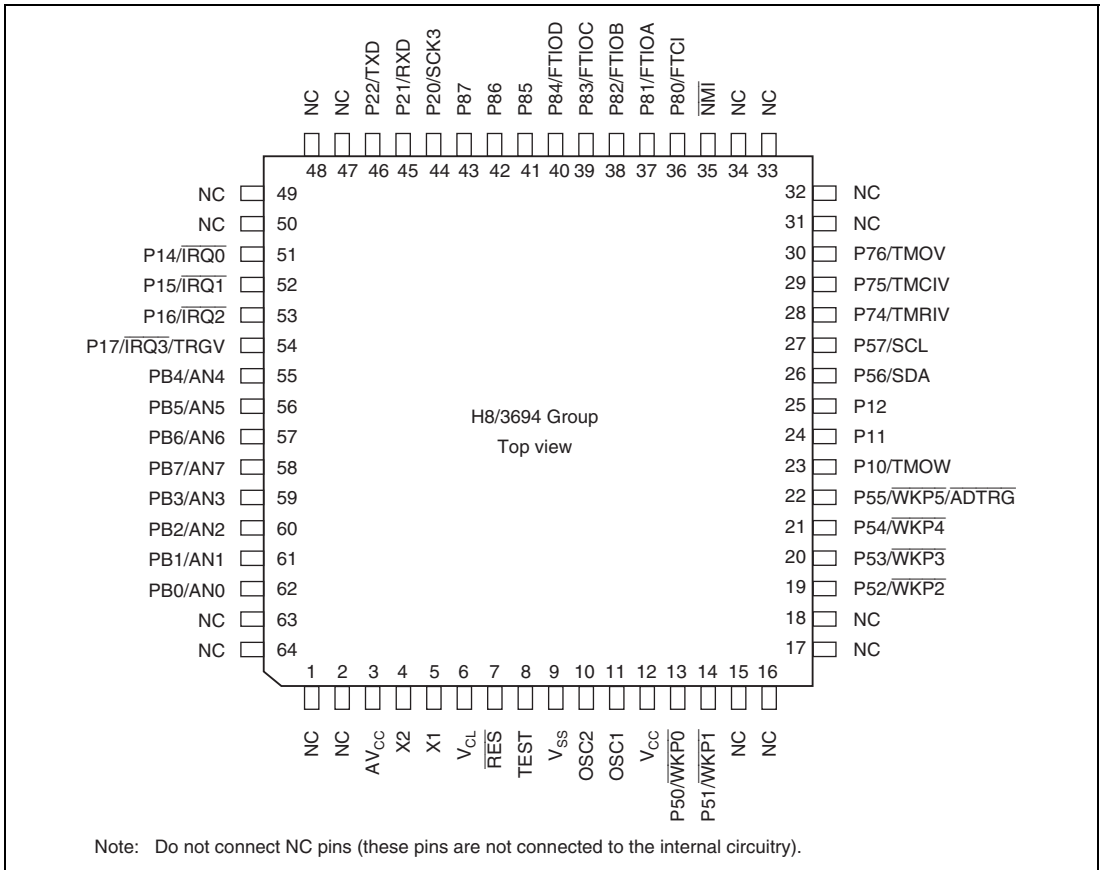

Figure 1.3 Pin Arrangement of H8/3694 Group of F-ZTAT™ and Mask-ROM Versions (FP-64E, FP-64A)

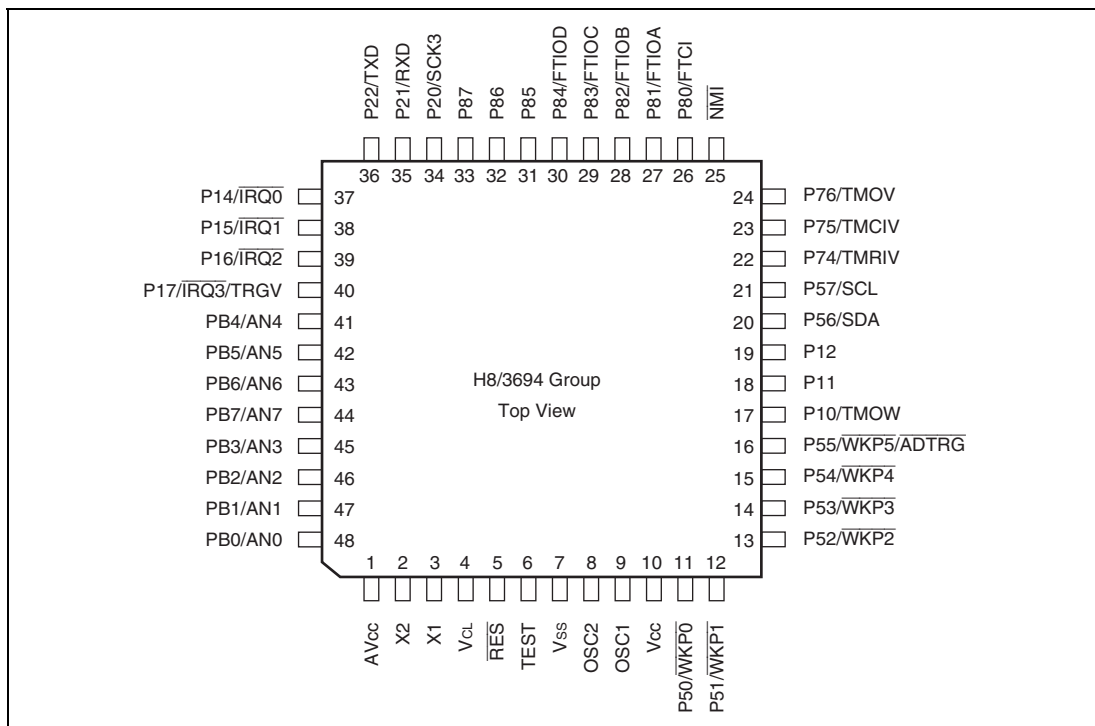

Figure 1.4 Pin Arrangement of H8/3694 Group of F-ZTAT™ and Mask-ROM Versions (FP-48F, FP-48B, TNP-48)

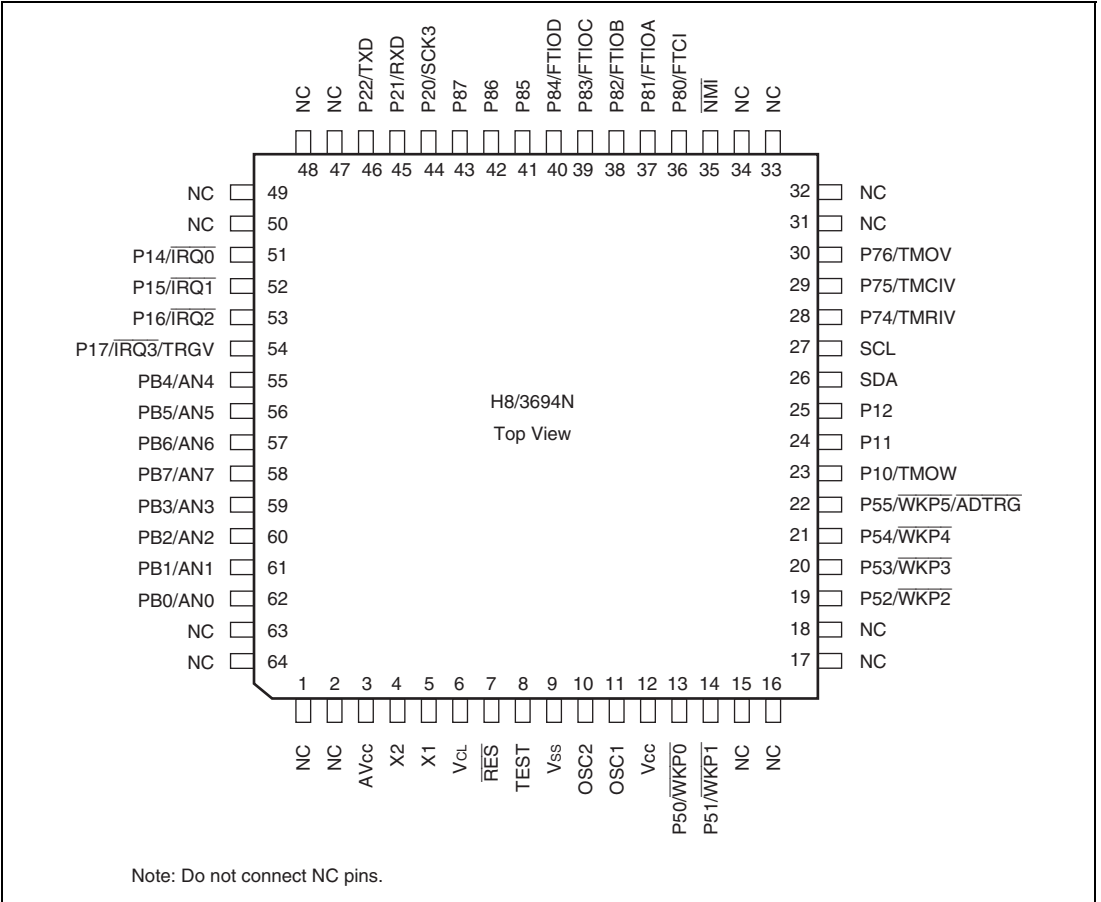

Figure 1.5 Pin Arrangement of H8/3694N (EEPROM Stacked Version) (FP-64E)

1.4 Pin Functions

Table 1.1 Pin Functions

| Type | Symbol | Pin No. | | I/O | Functions |
|-------------------|--|------------------|----------------------------|--------|---|
| | | FP-64E FP-64A | FP-48F FP-48B TNP-48 | | |
| Power source pins | V_{cc} | 12 | 10 | Input | Power supply pin. Connect this pin to the system power supply. |
| | V_{ss} | 9 | 7 | Input | Ground pin. Connect this pin to the system power supply (0V). |
| | AV_{cc} | 3 | 1 | Input | Analog power supply pin for the A/D converter. When the A/D converter is not used, connect this pin to the system power supply. |
| | V_{cl} | 6 | 4 | Input | Internal step-down power supply pin. Connect a capacitor of around 0.1 μ F between this pin and the Vss pin for stabilization. |
| Clock pins | OSC1 | 11 | 9 | Input | These pins connect with crystal or ceramic resonator for the system clock, or can be used to input an external clock. See section 5, Clock Pulse Generators, for a typical connection. |
| | OSC2 | 10 | 8 | Output | |
| | X1 | 5 | 3 | Input | These pins connect with a 32.768 kHz crystal resonator for the subclock. See section 5, Clock Pulse Generators, for a typical connection. |
| | X2 | 4 | 2 | Output | |
| System control | \overline{RES} | 7 | 5 | Input | Reset pin. The pull-up resistor (typ. 150 k Ω) is incorporated. When driven low, the chip is reset. |
| | TEST | 8 | 6 | Input | Test pin. Connect this pin to Vss. |
| Interrupt pins | \overline{NMI} | 35 | 25 | Input | Non-maskable interrupt request input pin. Be sure to pull-up by a pull-up resistor. |
| | $\overline{IRQ0}$ to $\overline{IRQ3}$ | 51 to 54 | 37 to 40 | Input | External interrupt request input pins. Can select the rising or falling edge. |
| | $\overline{WKP0}$ to $\overline{WKP5}$ | 13, 14, 19 to 22 | 11 to 16 | Input | External interrupt request input pins. Can select the rising or falling edge. |

| Type | Symbol | Pin No. | | I/O | Functions |
|--------------------------------------|---------------------------|---|----------------------------|---------------------|---|
| | | FP-64E FP-64A | FP-48F FP-48B TNP-48 | | |
| Timer A | TMOW | 23 | 17 | Output | This is an output pin for divided clocks. |
| Timer V | TMOV | 30 | 24 | Output | This is an output pin for waveforms generated by the output compare function. |
| | TMCIV | 29 | 23 | Input | External event input pin. |
| | TMRIV | 28 | 22 | Input | Counter reset input pin. |
| | TRGV | 54 | 40 | Input | Counter start trigger input pin. |
| Timer W | FTCI | 36 | 26 | Input | External event input pin. |
| | FTIOA to FTIOD | 37 to 40 | 27 to 30 | I/O | Output compare output/input capture input/PWM output pin |
| I ² C bus interface (IIC) | SDA | 26* ¹ | 20 | I/O | IIC data I/O pin. Can directly drive a bus by NMOS open-drain output. |
| | SCL | 27* ¹ | 21 | I/O (EEPROM: Input) | IIC clock I/O pin. Can directly drive a bus by NMOS open-drain output. |
| Serial communication interface (SCI) | TXD | 46 | 36 | Output | Transmit data output pin |
| | RXD | 45 | 35 | Input | Receive data input pin |
| | SCK3 | 44 | 34 | I/O | Clock I/O pin |
| A/D converter | AN7 to AN0 | 55 to 62 | 41 to 48 | Input | Analog input pin |
| | $\overline{\text{ADTRG}}$ | 22 | 16 | Input | A/D converter trigger input pin. |
| I/O ports | PB7 to PB0 | 55 to 62 | 41 to 48 | Input | 8-bit input port. |
| | P17 to P14, P12 to P10 | 51 to 54, 23 to 25 | 37 to 40, 17 to 19 | I/O | 7-bit I/O port. |
| | P22 to P20 | 44 to 46 | 34 to 36 | I/O | 3-bit I/O port. |
| | P57 to P50 | 13, 14, 19 to 22, 26* ² , 27* ² | 20, 21, 13 to 16, 11, 12 | I/O | 8-bit I/O port |

| Type | Symbol | Pin No. | | | I/O | Functions |
|-----------|---------------|------------------|----------------------------|-----|-----------------|-----------|
| | | FP-64E FP-64A | FP-48F FP-48B TNP-48 | | | |
| I/O ports | P76 to P74 | 28 to 30 | 22 to 24 | I/O | 3-bit I/O port | |
| | P87 to P80 | 36 to 43 | 26 to 33 | I/O | 8-bit I/O port. | |

- Notes:
1. These pins are only available for the I²C bus interface in the H8/3694N. Since the I²C bus is disabled after canceling a reset, the ICE bit in ICCR1 must be set to 1 by using the program.
 2. The P57 and P56 pins are not available in the H8/3694N.

Section 2 CPU

This LSI has an H8/300H CPU with an internal 32-bit architecture that is upward-compatible with the H8/300CPU, and supports only normal mode, which has a 64-kbyte address space.

- Upward-compatible with H8/300 CPUs
 - Can execute H8/300 CPUs object programs
 - Additional eight 16-bit extended registers
 - 32-bit transfer and arithmetic and logic instructions are added
 - Signed multiply and divide instructions are added.
- General-register architecture
 - Sixteen 16-bit general registers also usable as sixteen 8-bit registers and eight 16-bit registers, or eight 32-bit registers
- Sixty-two basic instructions
 - 8/16/32-bit data transfer and arithmetic and logic instructions
 - Multiply and divide instructions
 - Powerful bit-manipulation instructions
- Eight addressing modes
 - Register direct [Rn]
 - Register indirect [@ERn]
 - Register indirect with displacement [@(d:16,ERn) or @(d:24,ERn)]
 - Register indirect with post-increment or pre-decrement [@ERn+ or @-ERn]
 - Absolute address [@aa:8, @aa:16, @aa:24]
 - Immediate [#xx:8, #xx:16, or #xx:32]
 - Program-counter relative [@(d:8,PC) or @(d:16,PC)]
 - Memory indirect [@@aa:8]
- 64-kbyte address space
- High-speed operation
 - All frequently-used instructions execute in one or two states
 - 8/16/32-bit register-register add/subtract : 2 state
 - 8×8 -bit register-register multiply : 14 states
 - $16 \div 8$ -bit register-register divide : 14 states
 - 16×16 -bit register-register multiply : 22 states
 - $32 \div 16$ -bit register-register divide : 22 states
- Power-down state
 - Transition to power-down state by SLEEP instruction

2.1 Address Space and Memory Map

The address space of this LSI is 64 kbytes, which includes the program area and the data area. Figures 2.1 show the memory map.

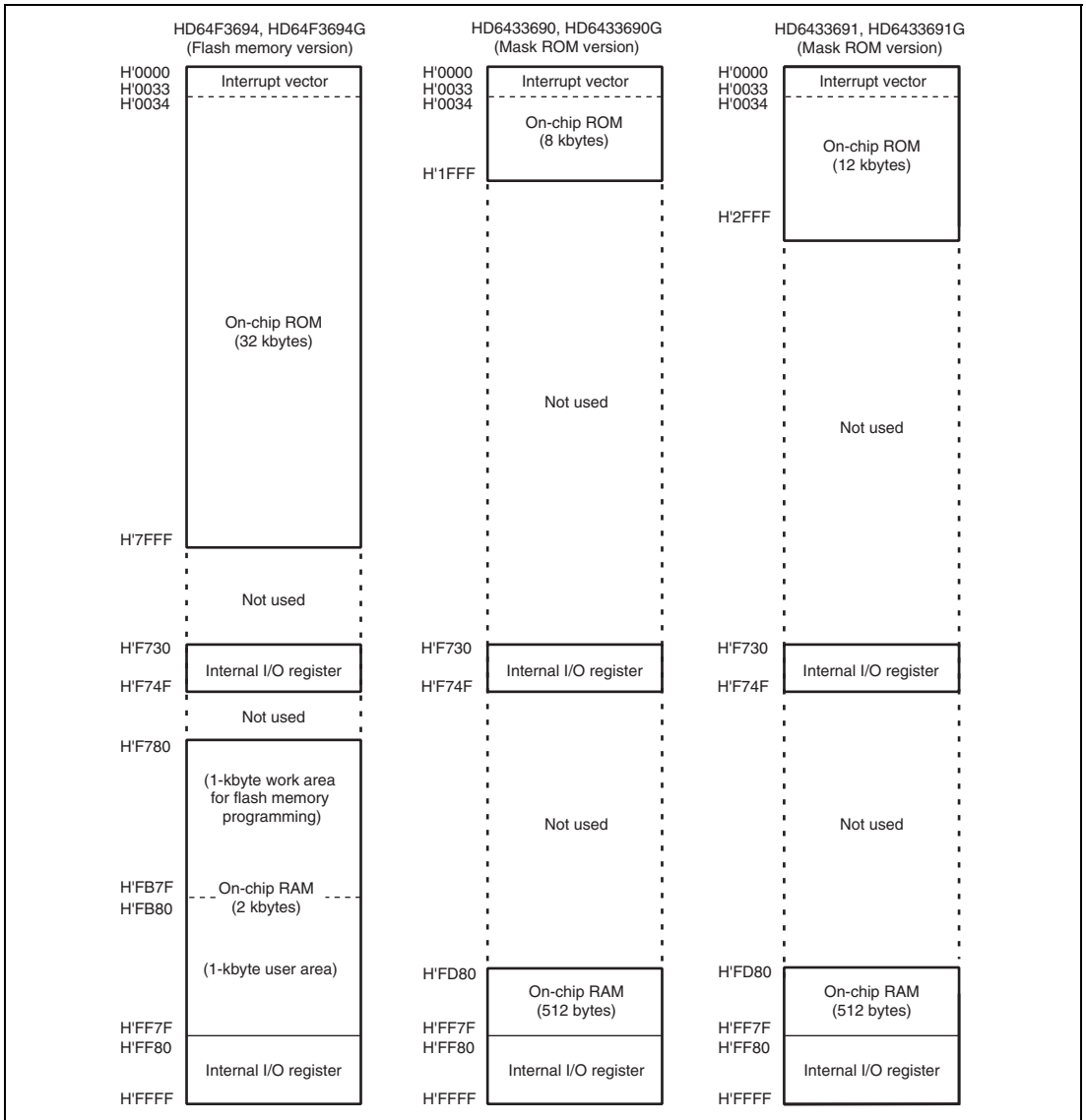

Figure 2.1 Memory Map (1)

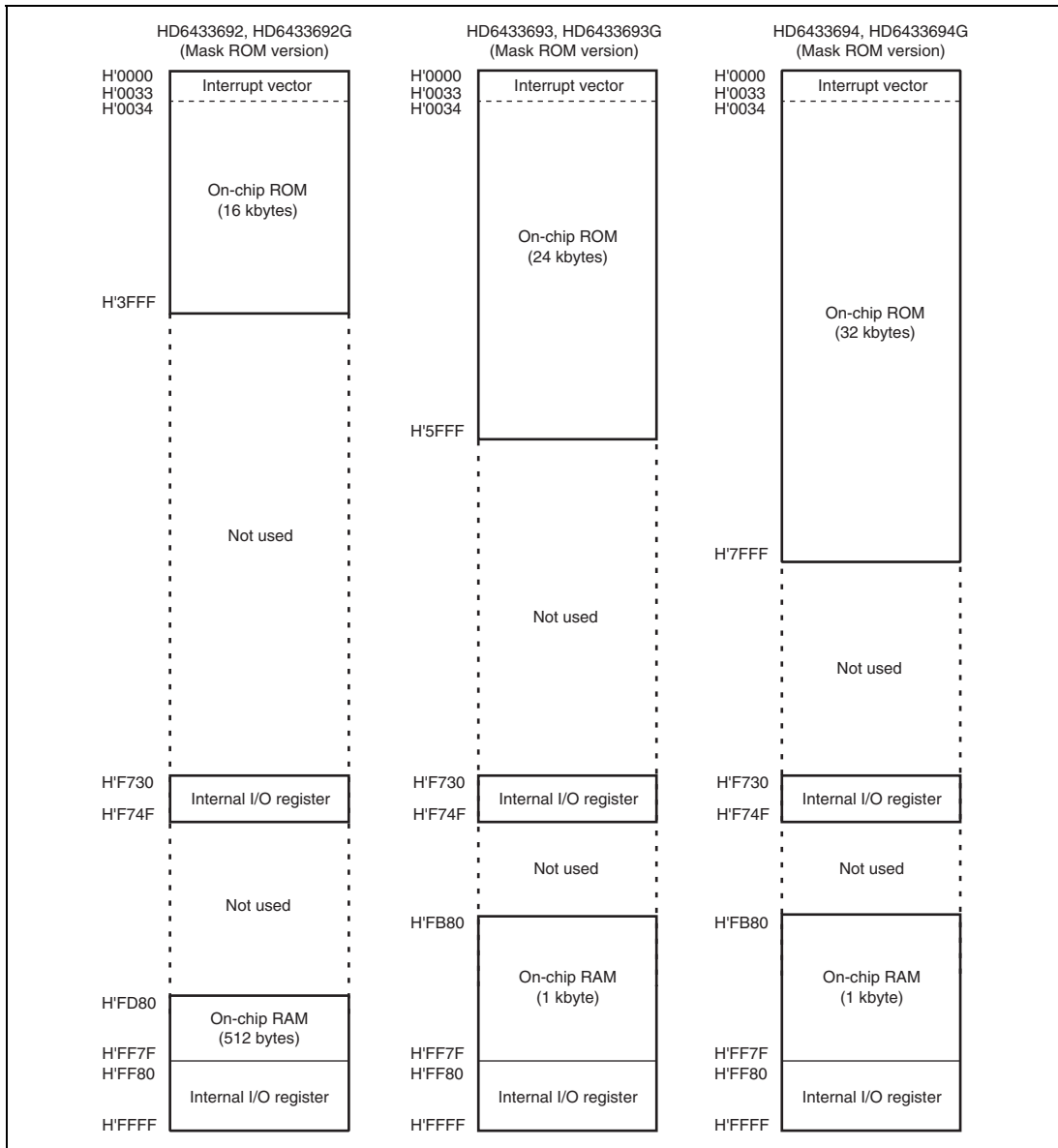

Figure 2.1 Memory Map (2)

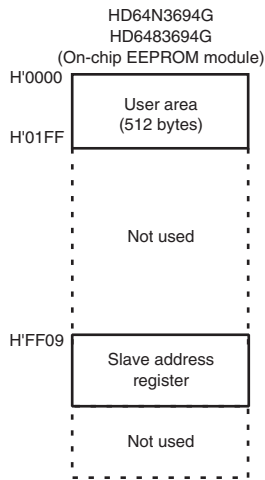

Figure 2.1 Memory Map (3)

2.2 Register Configuration

The H8/300H CPU has the internal registers shown in figure 2.2. There are two types of registers; general registers and control registers. The control registers are a 24-bit program counter (PC), and an 8-bit condition code register (CCR).

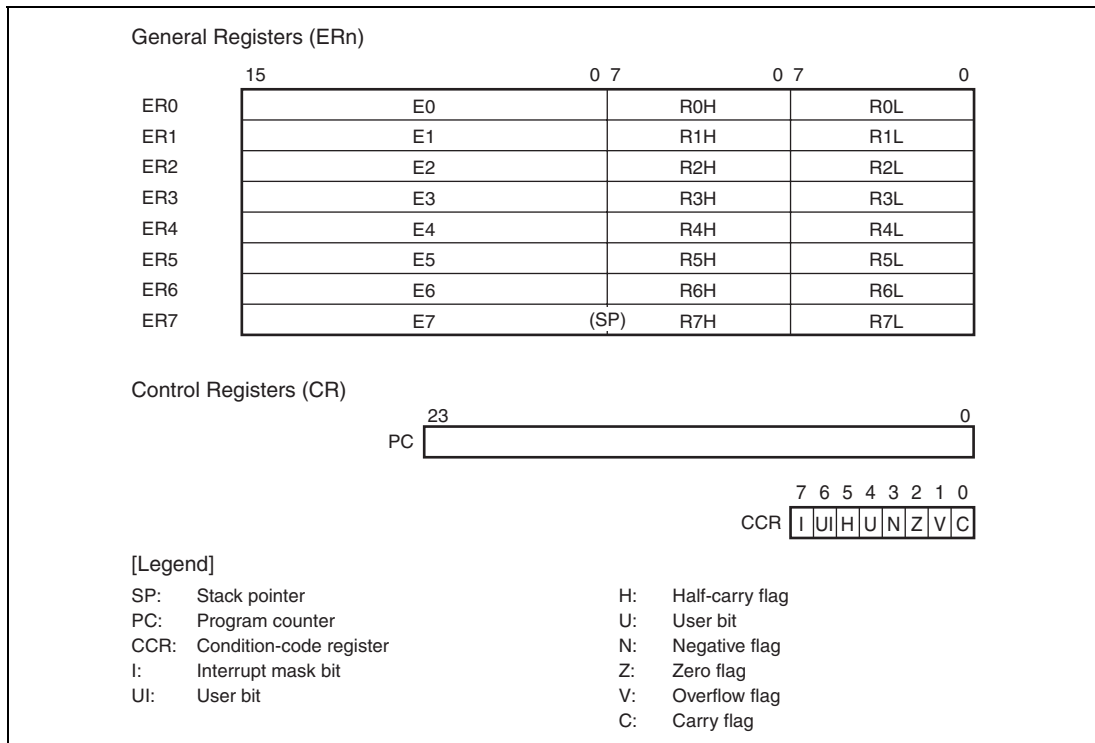

Figure 2.2 CPU Registers

2.2.1 General Registers

The H8/300H CPU has eight 32-bit general registers. These general registers are all functionally identical and can be used as both address registers and data registers. When a general register is used as a data register, it can be accessed as a 32-bit, 16-bit, or 8-bit register. Figure 2.3 illustrates the usage of the general registers. When the general registers are used as 32-bit registers or address registers, they are designated by the letters ER (ER0 to ER7).

The ER registers divide into 16-bit general registers designated by the letters E (E0 to E7) and R (R0 to R7). These registers are functionally equivalent, providing a maximum of sixteen 16-bit registers. The E registers (E0 to E7) are also referred to as extended registers.

The R registers divide into 8-bit registers designated by the letters RH (R0H to R7H) and RL (R0L to R7L). These registers are functionally equivalent, providing a maximum of sixteen 8-bit registers.

The usage of each register can be selected independently.

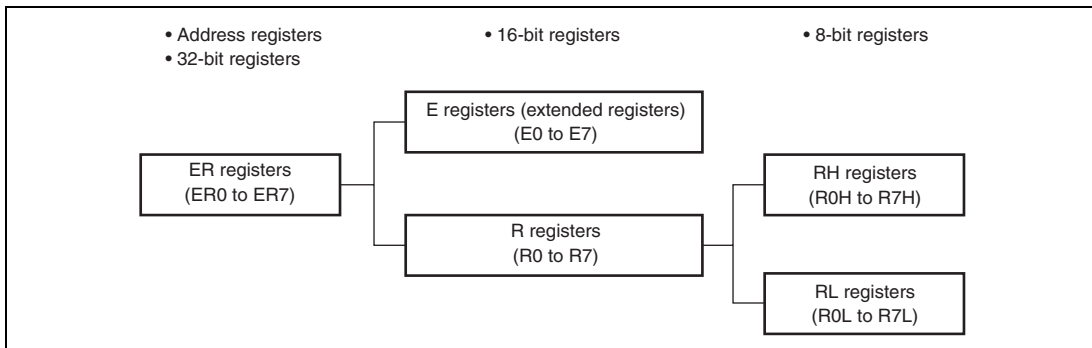

Figure 2.3 Usage of General Registers

General register ER7 has the function of stack pointer (SP) in addition to its general-register function, and is used implicitly in exception handling and subroutine calls. Figure 2.4 shows the relationship between stack pointer and the stack area.

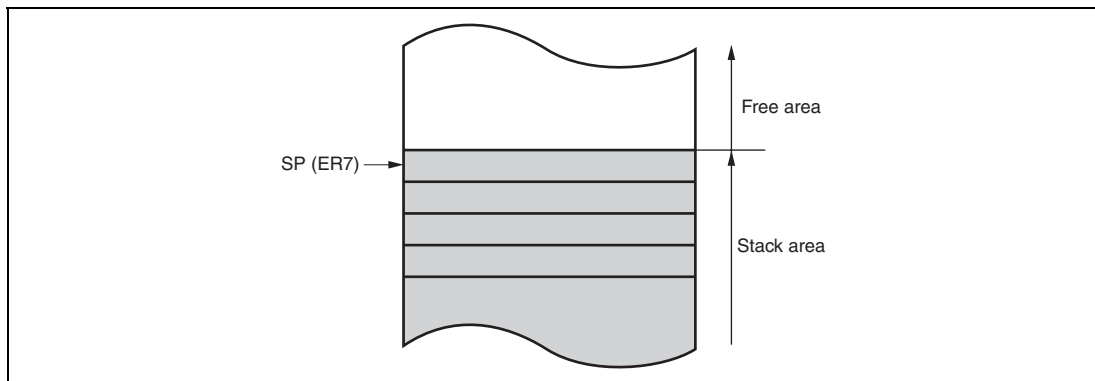

Figure 2.4 Relationship between Stack Pointer and Stack Area

2.2.2 Program Counter (PC)

This 24-bit counter indicates the address of the next instruction the CPU will execute. The length of all CPU instructions is 2 bytes (one word), so the least significant PC bit is ignored. (When an instruction is fetched, the least significant PC bit is regarded as 0). The PC is initialized when the start address is loaded by the vector address generated during reset exception-handling sequence.

2.2.3 Condition-Code Register (CCR)

This 8-bit register contains internal CPU status information, including an interrupt mask bit (I) and half-carry (H), negative (N), zero (Z), overflow (V), and carry (C) flags. The I bit is initialized to 1 by reset exception-handling sequence, but other bits are not initialized.

Some instructions leave flag bits unchanged. Operations can be performed on the CCR bits by the LDC, STC, ANDC, ORC, and XORC instructions. The N, Z, V, and C flags are used as branching conditions for conditional branch (Bcc) instructions.

For the action of each instruction on the flag bits, see appendix A.1, Instruction List.

| Bit | Bit Name | Initial Value | R/W | Description |
|-----|----------|---------------|-----|---|
| 7 | I | 1 | R/W | <p>Interrupt Mask Bit</p> <p>Masks interrupts other than NMI when set to 1. NMI is accepted regardless of the I bit setting. The I bit is set to 1 at the start of an exception-handling sequence.</p> |
| 6 | UI | Undefined | R/W | <p>User Bit</p> <p>Can be written and read by software using the LDC, STC, ANDC, ORC, and XORC instructions.</p> |
| 5 | H | Undefined | R/W | <p>Half-Carry Flag</p> <p>When the ADD.B, ADDX.B, SUB.B, SUBX.B, CMP.B, or NEG.B instruction is executed, this flag is set to 1 if there is a carry or borrow at bit 3, and cleared to 0 otherwise. When the ADD.W, SUB.W, CMP.W, or NEG.W instruction is executed, the H flag is set to 1 if there is a carry or borrow at bit 11, and cleared to 0 otherwise. When the ADD.L, SUB.L, CMP.L, or NEG.L instruction is executed, the H flag is set to 1 if there is a carry or borrow at bit 27, and cleared to 0 otherwise.</p> |
| 4 | U | Undefined | R/W | <p>User Bit</p> <p>Can be written and read by software using the LDC, STC, ANDC, ORC, and XORC instructions.</p> |
| 3 | N | Undefined | R/W | <p>Negative Flag</p> <p>Stores the value of the most significant bit of data as a sign bit.</p> |
| 2 | Z | Undefined | R/W | <p>Zero Flag</p> <p>Set to 1 to indicate zero data, and cleared to 0 to indicate non-zero data.</p> |
| 1 | V | Undefined | R/W | <p>Overflow Flag</p> <p>Set to 1 when an arithmetic overflow occurs, and cleared to 0 at other times.</p> |
| 0 | C | Undefined | R/W | <p>Carry Flag</p> <p>Set to 1 when a carry occurs, and cleared to 0 otherwise. Used by:</p> <ul style="list-style-type: none"> • Add instructions, to indicate a carry • Subtract instructions, to indicate a borrow • Shift and rotate instructions, to indicate a carry <p>The carry flag is also used as a bit accumulator by bit manipulation instructions.</p> |

2.3 Data Formats

The H8/300H CPU can process 1-bit, 4-bit (BCD), 8-bit (byte), 16-bit (word), and 32-bit (longword) data. Bit-manipulation instructions operate on 1-bit data by accessing bit n ($n = 0, 1, 2, \dots, 7$) of byte operand data. The DAA and DAS decimal-adjust instructions treat byte data as two digits of 4-bit BCD data.

2.3.1 General Register Data Formats

Figure 2.5 shows the data formats in general registers.

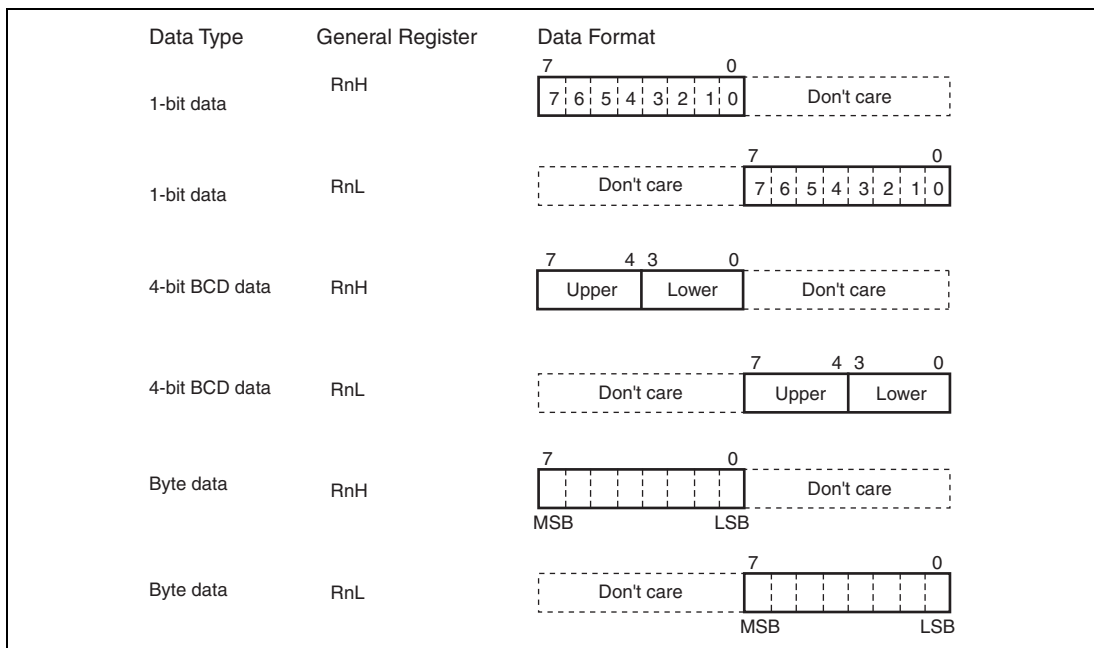

Figure 2.5 General Register Data Formats (1)

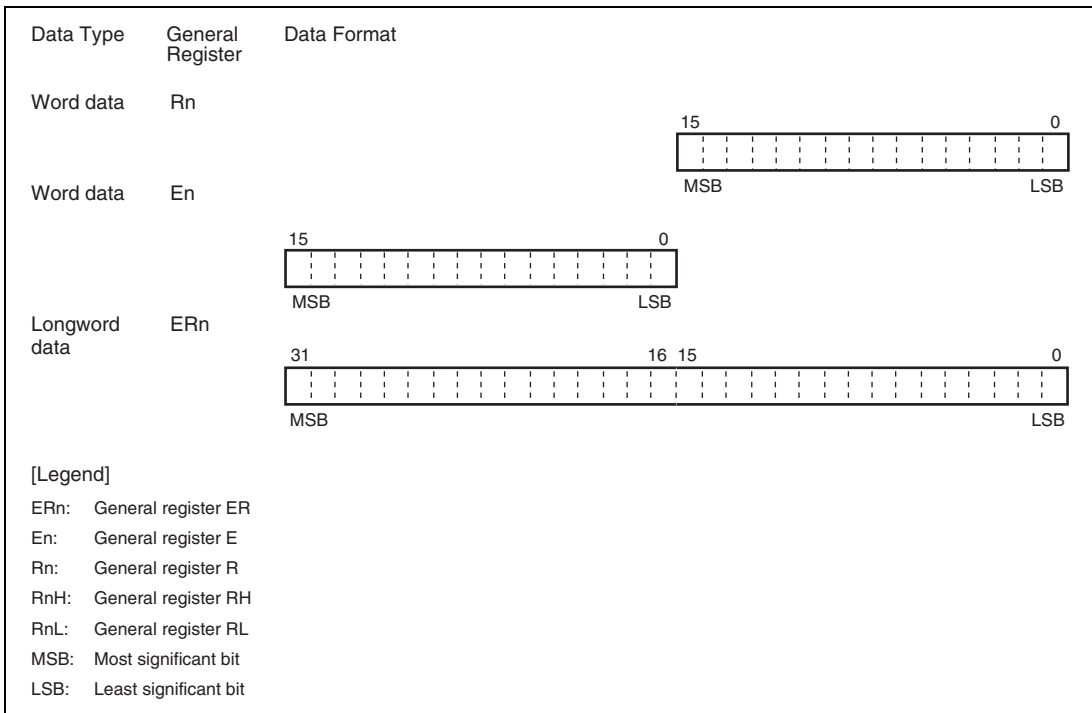

Figure 2.5 General Register Data Formats (2)

2.3.2 Memory Data Formats

Figure 2.6 shows the data formats in memory. The H8/300H CPU can access word data and longword data in memory, however word or longword data must begin at an even address. If an attempt is made to access word or longword data at an odd address, an address error does not occur, however the least significant bit of the address is regarded as 0, so access begins the preceding address. This also applies to instruction fetches.

When ER7 (SP) is used as an address register to access the stack area, the operand size should be word or longword.

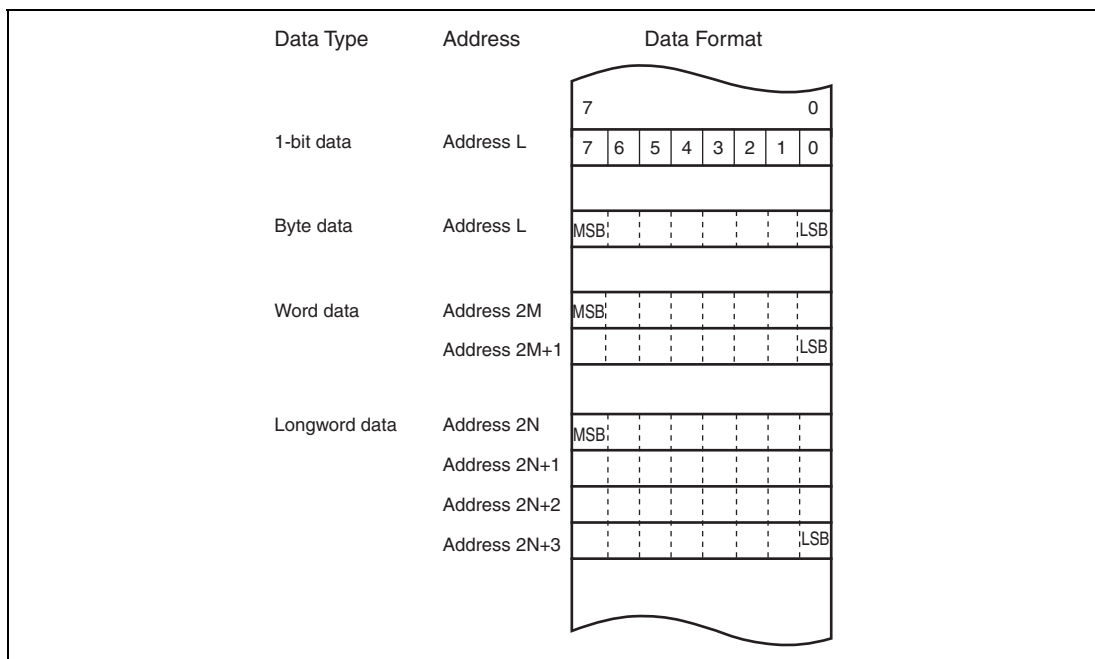

Figure 2.6 Memory Data Formats

2.4 Instruction Set

2.4.1 Table of Instructions Classified by Function

The H8/300H CPU has 62 instructions. Tables 2.2 to 2.9 summarize the instructions in each functional category. The notation used in tables 2.2 to 2.9 is defined below.

Table 2.1 Operation Notation

| Symbol | Description |
|---------------|--|
| Rd | General register (destination)* |
| Rs | General register (source)* |
| Rn | General register* |
| ERn | General register (32-bit register or address register) |
| (EAd) | Destination operand |
| (EAs) | Source operand |
| CCR | Condition-code register |
| N | N (negative) flag in CCR |
| Z | Z (zero) flag in CCR |
| V | V (overflow) flag in CCR |
| C | C (carry) flag in CCR |
| PC | Program counter |
| SP | Stack pointer |
| #IMM | Immediate data |
| disp | Displacement |
| + | Addition |
| − | Subtraction |
| × | Multiplication |
| ÷ | Division |
| ^ | Logical AND |
| ∨ | Logical OR |
| ⊕ | Logical XOR |
| → | Move |
| ¬ | NOT (logical complement) |
| :3/:8/:16/:24 | 3-, 8-, 16-, or 24-bit length |

Note: * General registers include 8-bit registers (R0H to R7H, R0L to R7L), 16-bit registers (R0 to R7, E0 to E7), and 32-bit registers/address register (ER0 to ER7).

Table 2.2 Data Transfer Instructions

| Instruction | Size* | Function |
|--------------------|--------------|---|
| MOV | B/W/L | (EAs) → Rd, Rs → (EAd) Moves data between two general registers or between a general register and memory, or moves immediate data to a general register. |
| MOVFPE | B | (EAs) → Rd, Cannot be used in this LSI. |
| MOVTPE | B | Rs → (EAs) Cannot be used in this LSI. |
| POP | W/L | @SP+ → Rn Pops a general register from the stack. POP.W Rn is identical to MOV.W @SP+, Rn. POP.L ERn is identical to MOV.L @SP+, ERn. |
| PUSH | W/L | Rn → @-SP Pushes a general register onto the stack. PUSH.W Rn is identical to MOV.W Rn, @-SP. PUSH.L ERn is identical to MOV.L ERn, @-SP. |

Note: * Refers to the operand size.

B: Byte

W: Word

L: Longword

Table 2.3 Arithmetic Operations Instructions (1)

| Instruction | Size* | Function |
|--------------------|--------------|--|
| ADD SUB | B/W/L | $Rd \pm Rs \rightarrow Rd$, $Rd \pm \#IMM \rightarrow Rd$ Performs addition or subtraction on data in two general registers, or on immediate data and data in a general register (immediate byte data cannot be subtracted from byte data in a general register. Use the SUBX or ADD instruction.) |
| ADDX SUBX | B | $Rd \pm Rs \pm C \rightarrow Rd$, $Rd \pm \#IMM \pm C \rightarrow Rd$ Performs addition or subtraction with carry on byte data in two general registers, or on immediate data and data in a general register. |
| INC DEC | B/W/L | $Rd \pm 1 \rightarrow Rd$, $Rd \pm 2 \rightarrow Rd$ Increments or decrements a general register by 1 or 2. (Byte operands can be incremented or decremented by 1 only.) |
| ADDS SUBS | L | $Rd \pm 1 \rightarrow Rd$, $Rd \pm 2 \rightarrow Rd$, $Rd \pm 4 \rightarrow Rd$ Adds or subtracts the value 1, 2, or 4 to or from data in a 32-bit register. |
| DAA DAS | B | Rd decimal adjust $\rightarrow Rd$ Decimal-adjusts an addition or subtraction result in a general register by referring to the CCR to produce 4-bit BCD data. |
| MULXU | B/W | $Rd \times Rs \rightarrow Rd$ Performs unsigned multiplication on data in two general registers: either 8 bits \times 8 bits \rightarrow 16 bits or 16 bits \times 16 bits \rightarrow 32 bits. |
| MULXS | B/W | $Rd \times Rs \rightarrow Rd$ Performs signed multiplication on data in two general registers: either 8 bits \times 8 bits \rightarrow 16 bits or 16 bits \times 16 bits \rightarrow 32 bits. |
| DIVXU | B/W | $Rd \div Rs \rightarrow Rd$ Performs unsigned division on data in two general registers: either 16 bits \div 8 bits \rightarrow 8-bit quotient and 8-bit remainder or 32 bits \div 16 bits \rightarrow 16-bit quotient and 16-bit remainder. |

Note: * Refers to the operand size.

B: Byte

W: Word

L: Longword

Table 2.3 Arithmetic Operations Instructions (2)

| Instruction | Size* | Function |
|--------------------|--------------|---|
| DIVXS | B/W | $Rd \div Rs \rightarrow Rd$ Performs signed division on data in two general registers: either 16 bits \div 8 bits \rightarrow 8-bit quotient and 8-bit remainder or 32 bits \div 16 bits \rightarrow 16-bit quotient and 16-bit remainder. |
| CMP | B/W/L | $Rd - Rs, Rd - \#IMM$ Compares data in a general register with data in another general register or with immediate data, and sets CCR bits according to the result. |
| NEG | B/W/L | $0 - Rd \rightarrow Rd$ Takes the two's complement (arithmetic complement) of data in a general register. |
| EXTU | W/L | Rd (zero extension) $\rightarrow Rd$ Extends the lower 8 bits of a 16-bit register to word size, or the lower 16 bits of a 32-bit register to longword size, by padding with zeros on the left. |
| EXTS | W/L | Rd (sign extension) $\rightarrow Rd$ Extends the lower 8 bits of a 16-bit register to word size, or the lower 16 bits of a 32-bit register to longword size, by extending the sign bit. |

Note: * Refers to the operand size.

B: Byte

W: Word

L: Longword

Table 2.4 Logic Operations Instructions

| Instruction | Size* | Function |
|--------------------|--------------|---|
| AND | B/W/L | $Rd \wedge Rs \rightarrow Rd$, $Rd \wedge \#IMM \rightarrow Rd$ Performs a logical AND operation on a general register and another general register or immediate data. |
| OR | B/W/L | $Rd \vee Rs \rightarrow Rd$, $Rd \vee \#IMM \rightarrow Rd$ Performs a logical OR operation on a general register and another general register or immediate data. |
| XOR | B/W/L | $Rd \oplus Rs \rightarrow Rd$, $Rd \oplus \#IMM \rightarrow Rd$ Performs a logical exclusive OR operation on a general register and another general register or immediate data. |
| NOT | B/W/L | $\neg (Rd) \rightarrow (Rd)$ Takes the one's complement (logical complement) of general register contents. |

Note: * Refers to the operand size.

B: Byte

W: Word

L: Longword

Table 2.5 Shift Instructions

| Instruction | Size* | Function |
|--------------------|--------------|---|
| SHAL SHAR | B/W/L | $Rd \text{ (shift)} \rightarrow Rd$ Performs an arithmetic shift on general register contents. |
| SHLL SHLR | B/W/L | $Rd \text{ (shift)} \rightarrow Rd$ Performs a logical shift on general register contents. |
| ROTL ROTR | B/W/L | $Rd \text{ (rotate)} \rightarrow Rd$ Rotates general register contents. |
| ROTXL ROTXR | B/W/L | $Rd \text{ (rotate)} \rightarrow Rd$ Rotates general register contents through the carry flag. |

Note: * Refers to the operand size.

B: Byte

W: Word

L: Longword

Table 2.6 Bit Manipulation Instructions (1)

| Instruction | Size* | Function |
|-------------|-------|---|
| BSET | B | $1 \rightarrow \langle \text{bit-No.} \rangle \text{ of } \langle \text{EAd} \rangle$ Sets a specified bit in a general register or memory operand to 1. The bit number is specified by 3-bit immediate data or the lower three bits of a general register. |
| BCLR | B | $0 \rightarrow \langle \text{bit-No.} \rangle \text{ of } \langle \text{EAd} \rangle$ Clears a specified bit in a general register or memory operand to 0. The bit number is specified by 3-bit immediate data or the lower three bits of a general register. |
| BNOT | B | $\neg \langle \text{bit-No.} \rangle \text{ of } \langle \text{EAd} \rangle \rightarrow \langle \text{bit-No.} \rangle \text{ of } \langle \text{EAd} \rangle$ Inverts a specified bit in a general register or memory operand. The bit number is specified by 3-bit immediate data or the lower three bits of a general register. |
| BTST | B | $\neg \langle \text{bit-No.} \rangle \text{ of } \langle \text{EAd} \rangle \rightarrow Z$ Tests a specified bit in a general register or memory operand and sets or clears the Z flag accordingly. The bit number is specified by 3-bit immediate data or the lower three bits of a general register. |
| BAND | B | $C \wedge \langle \text{bit-No.} \rangle \text{ of } \langle \text{EAd} \rangle \rightarrow C$ ANDs the carry flag with a specified bit in a general register or memory operand and stores the result in the carry flag. |
| BIAND | B | $C \wedge \neg \langle \text{bit-No.} \rangle \text{ of } \langle \text{EAd} \rangle \rightarrow C$ ANDs the carry flag with the inverse of a specified bit in a general register or memory operand and stores the result in the carry flag. The bit number is specified by 3-bit immediate data. |
| BOR | B | $C \vee \langle \text{bit-No.} \rangle \text{ of } \langle \text{EAd} \rangle \rightarrow C$ ORs the carry flag with a specified bit in a general register or memory operand and stores the result in the carry flag. |
| BIOR | B | $C \vee \neg \langle \text{bit-No.} \rangle \text{ of } \langle \text{EAd} \rangle \rightarrow C$ ORs the carry flag with the inverse of a specified bit in a general register or memory operand and stores the result in the carry flag. The bit number is specified by 3-bit immediate data. |

Note: * Refers to the operand size.

B: Byte

Table 2.6 Bit Manipulation Instructions (2)

| Instruction | Size* | Function |
|--------------------|--------------|---|
| BXOR | B | $C \oplus (\text{<bit-No.> of <EAd>}) \rightarrow C$ XORs the carry flag with a specified bit in a general register or memory operand and stores the result in the carry flag. |
| BIXOR | B | $C \oplus \neg (\text{<bit-No.> of <EAd>}) \rightarrow C$ XORs the carry flag with the inverse of a specified bit in a general register or memory operand and stores the result in the carry flag. The bit number is specified by 3-bit immediate data. |
| BLD | B | $(\text{<bit-No.> of <EAd>}) \rightarrow C$ Transfers a specified bit in a general register or memory operand to the carry flag. |
| BILD | B | $\neg (\text{<bit-No.> of <EAd>}) \rightarrow C$ Transfers the inverse of a specified bit in a general register or memory operand to the carry flag. The bit number is specified by 3-bit immediate data. |
| BST | B | $C \rightarrow (\text{<bit-No.> of <EAd>})$ Transfers the carry flag value to a specified bit in a general register or memory operand. |
| BIST | B | $\neg C \rightarrow (\text{<bit-No.> of <EAd>})$ Transfers the inverse of the carry flag value to a specified bit in a general register or memory operand. The bit number is specified by 3-bit immediate data. |

Note: * Refers to the operand size.

B: Byte

Table 2.7 Branch Instructions

| Instruction | Size | Function | | | | | | | | | | | | | | | | | | | | | | | | | | | | | | | | | | | | | | | | | | | | | | | | | | | |
|--------------------|-------------------------------|---|-----------------|--------------------|------------------|---------|---------------|--------|---------|---------------|-------|-----|------|----------------|-----|-------------|----------------|----------|-------------------------------|---------|----------|-----------------|---------|-----|-----------|---------|-----|-------|---------|-----|----------------|---------|-----|--------------|---------|-----|------|---------|-----|-------|---------|-----|------------------|------------------|-----|-----------|------------------|-----|--------------|---------------------------|-----|---------------|---------------------------|
| Bcc* | — | Branches to a specified address if a specified condition is true. The branching conditions are listed below. | | | | | | | | | | | | | | | | | | | | | | | | | | | | | | | | | | | | | | | | | | | | | | | | | | | |
| | | <table border="1"> <thead> <tr> <th>Mnemonic</th> <th>Description</th> <th>Condition</th> </tr> </thead> <tbody> <tr> <td>BRA(BT)</td> <td>Always (true)</td> <td>Always</td> </tr> <tr> <td>BRN(BF)</td> <td>Never (false)</td> <td>Never</td> </tr> <tr> <td>BHI</td> <td>High</td> <td>$C \vee Z = 0$</td> </tr> <tr> <td>BLS</td> <td>Low or same</td> <td>$C \vee Z = 1$</td> </tr> <tr> <td>BCC(BHS)</td> <td>Carry clear (high or same)</td> <td>$C = 0$</td> </tr> <tr> <td>BCS(BLO)</td> <td>Carry set (low)</td> <td>$C = 1$</td> </tr> <tr> <td>BNE</td> <td>Not equal</td> <td>$Z = 0$</td> </tr> <tr> <td>BEQ</td> <td>Equal</td> <td>$Z = 1$</td> </tr> <tr> <td>BVC</td> <td>Overflow clear</td> <td>$V = 0$</td> </tr> <tr> <td>BVS</td> <td>Overflow set</td> <td>$V = 1$</td> </tr> <tr> <td>BPL</td> <td>Plus</td> <td>$N = 0$</td> </tr> <tr> <td>BMI</td> <td>Minus</td> <td>$N = 1$</td> </tr> <tr> <td>BGE</td> <td>Greater or equal</td> <td>$N \oplus V = 0$</td> </tr> <tr> <td>BLT</td> <td>Less than</td> <td>$N \oplus V = 1$</td> </tr> <tr> <td>BGT</td> <td>Greater than</td> <td>$Z \vee (N \oplus V) = 0$</td> </tr> <tr> <td>BLE</td> <td>Less or equal</td> <td>$Z \vee (N \oplus V) = 1$</td> </tr> </tbody> </table> | Mnemonic | Description | Condition | BRA(BT) | Always (true) | Always | BRN(BF) | Never (false) | Never | BHI | High | $C \vee Z = 0$ | BLS | Low or same | $C \vee Z = 1$ | BCC(BHS) | Carry clear (high or same) | $C = 0$ | BCS(BLO) | Carry set (low) | $C = 1$ | BNE | Not equal | $Z = 0$ | BEQ | Equal | $Z = 1$ | BVC | Overflow clear | $V = 0$ | BVS | Overflow set | $V = 1$ | BPL | Plus | $N = 0$ | BMI | Minus | $N = 1$ | BGE | Greater or equal | $N \oplus V = 0$ | BLT | Less than | $N \oplus V = 1$ | BGT | Greater than | $Z \vee (N \oplus V) = 0$ | BLE | Less or equal | $Z \vee (N \oplus V) = 1$ |
| Mnemonic | Description | Condition | | | | | | | | | | | | | | | | | | | | | | | | | | | | | | | | | | | | | | | | | | | | | | | | | | | |
| BRA(BT) | Always (true) | Always | | | | | | | | | | | | | | | | | | | | | | | | | | | | | | | | | | | | | | | | | | | | | | | | | | | |
| BRN(BF) | Never (false) | Never | | | | | | | | | | | | | | | | | | | | | | | | | | | | | | | | | | | | | | | | | | | | | | | | | | | |
| BHI | High | $C \vee Z = 0$ | | | | | | | | | | | | | | | | | | | | | | | | | | | | | | | | | | | | | | | | | | | | | | | | | | | |
| BLS | Low or same | $C \vee Z = 1$ | | | | | | | | | | | | | | | | | | | | | | | | | | | | | | | | | | | | | | | | | | | | | | | | | | | |
| BCC(BHS) | Carry clear (high or same) | $C = 0$ | | | | | | | | | | | | | | | | | | | | | | | | | | | | | | | | | | | | | | | | | | | | | | | | | | | |
| BCS(BLO) | Carry set (low) | $C = 1$ | | | | | | | | | | | | | | | | | | | | | | | | | | | | | | | | | | | | | | | | | | | | | | | | | | | |
| BNE | Not equal | $Z = 0$ | | | | | | | | | | | | | | | | | | | | | | | | | | | | | | | | | | | | | | | | | | | | | | | | | | | |
| BEQ | Equal | $Z = 1$ | | | | | | | | | | | | | | | | | | | | | | | | | | | | | | | | | | | | | | | | | | | | | | | | | | | |
| BVC | Overflow clear | $V = 0$ | | | | | | | | | | | | | | | | | | | | | | | | | | | | | | | | | | | | | | | | | | | | | | | | | | | |
| BVS | Overflow set | $V = 1$ | | | | | | | | | | | | | | | | | | | | | | | | | | | | | | | | | | | | | | | | | | | | | | | | | | | |
| BPL | Plus | $N = 0$ | | | | | | | | | | | | | | | | | | | | | | | | | | | | | | | | | | | | | | | | | | | | | | | | | | | |
| BMI | Minus | $N = 1$ | | | | | | | | | | | | | | | | | | | | | | | | | | | | | | | | | | | | | | | | | | | | | | | | | | | |
| BGE | Greater or equal | $N \oplus V = 0$ | | | | | | | | | | | | | | | | | | | | | | | | | | | | | | | | | | | | | | | | | | | | | | | | | | | |
| BLT | Less than | $N \oplus V = 1$ | | | | | | | | | | | | | | | | | | | | | | | | | | | | | | | | | | | | | | | | | | | | | | | | | | | |
| BGT | Greater than | $Z \vee (N \oplus V) = 0$ | | | | | | | | | | | | | | | | | | | | | | | | | | | | | | | | | | | | | | | | | | | | | | | | | | | |
| BLE | Less or equal | $Z \vee (N \oplus V) = 1$ | | | | | | | | | | | | | | | | | | | | | | | | | | | | | | | | | | | | | | | | | | | | | | | | | | | |
| JMP | — | Branches unconditionally to a specified address. | | | | | | | | | | | | | | | | | | | | | | | | | | | | | | | | | | | | | | | | | | | | | | | | | | | |
| BSR | — | Branches to a subroutine at a specified address. | | | | | | | | | | | | | | | | | | | | | | | | | | | | | | | | | | | | | | | | | | | | | | | | | | | |
| JSR | — | Branches to a subroutine at a specified address. | | | | | | | | | | | | | | | | | | | | | | | | | | | | | | | | | | | | | | | | | | | | | | | | | | | |
| RTS | — | Returns from a subroutine | | | | | | | | | | | | | | | | | | | | | | | | | | | | | | | | | | | | | | | | | | | | | | | | | | | |

Note : * Bcc is the general name for conditional branch instructions.

Table 2.8 System Control Instructions

| Instruction | Size* | Function |
|--------------------|--------------|---|
| TRAPA | — | Starts trap-instruction exception handling. |
| RTE | — | Returns from an exception-handling routine. |
| SLEEP | — | Causes a transition to a power-down state. |
| LDC | B/W | (EAs) → CCR Moves the source operand contents to the CCR. The CCR size is one byte, but in transfer from memory, data is read by word access. |
| STC | B/W | CCR → (EAd) Transfers the CCR contents to a destination location. The condition code register size is one byte, but in transfer to memory, data is written by word access. |
| ANDC | B | CCR ∧ #IMM → CCR Logically ANDs the CCR with immediate data. |
| ORC | B | CCR ∨ #IMM → CCR Logically ORs the CCR with immediate data. |
| XORC | B | CCR ⊕ #IMM → CCR Logically XORs the CCR with immediate data. |
| NOP | — | PC + 2 → PC Only increments the program counter. |

Note: * Refers to the operand size.

B: Byte

W: Word

Table 2.9 Block Data Transfer Instructions

| Instruction | Size | Function |
|-------------|------|--|
| EEPMOV.B | — | if R4L \neq 0 then Repeat @ER5+ \rightarrow @ER6+, R4L-1 \rightarrow R4L Until R4L = 0 else next; |
| EEPMOV.W | — | if R4 \neq 0 then Repeat @ER5+ \rightarrow @ER6+, R4-1 \rightarrow R4 Until R4 = 0 else next; Transfers a data block. Starting from the address set in ER5, transfers data for the number of bytes set in R4L or R4 to the address location set in ER6. Execution of the next instruction begins as soon as the transfer is completed. |

2.4.2 Basic Instruction Formats

H8/300H CPU instructions consist of 2-byte (1-word) units. An instruction consists of an operation field (op), a register field (r), an effective address extension (EA), and a condition field (cc).

Figure 2.7 shows examples of instruction formats.

- **Operation Field**
Indicates the function of the instruction, the addressing mode, and the operation to be carried out on the operand. The operation field always includes the first four bits of the instruction. Some instructions have two operation fields.
- **Register Field**
Specifies a general register. Address registers are specified by 3 bits, and data registers by 3 bits or 4 bits. Some instructions have two register fields. Some have no register field.
- **Effective Address Extension**
8, 16, or 32 bits specifying immediate data, an absolute address, or a displacement. A24-bit address or displacement is treated as a 32-bit data in which the first 8 bits are 0 (H'00).
- **Condition Field**
Specifies the branching condition of Bcc instructions.

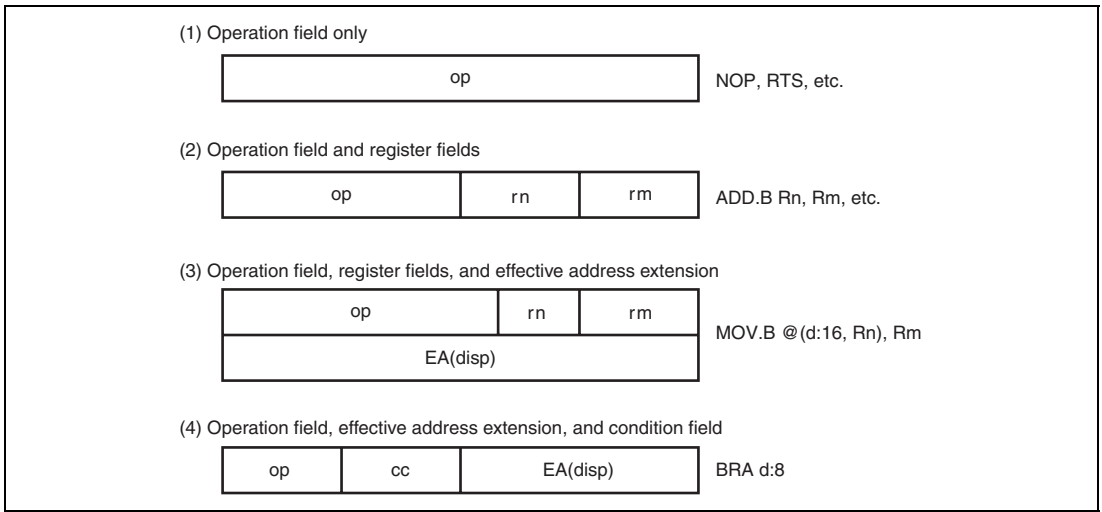

Figure 2.7 Instruction Formats

2.5 Addressing Modes and Effective Address Calculation

The following describes the H8/300H CPU. In this LSI, the upper eight bits are ignored in the generated 24-bit address, so the effective address is 16 bits.

2.5.1 Addressing Modes

The H8/300H CPU supports the eight addressing modes listed in table 2.10. Each instruction uses a subset of these addressing modes. Addressing modes that can be used differ depending on the instruction. For details, refer to appendix A.4, Combinations of Instructions and Addressing Modes.

Arithmetic and logic instructions can use the register direct and immediate modes. Data transfer instructions can use all addressing modes except program-counter relative and memory indirect. Bit manipulation instructions use register direct, register indirect, or the absolute addressing mode (@aa:8) to specify an operand, and register direct (BSET, BCLR, BNOT, and BTST instructions) or immediate (3-bit) addressing mode to specify a bit number in the operand.

Table 2.10 Addressing Modes

| No. | Addressing Mode | Symbol |
|-----|---|-------------------------|
| 1 | Register direct | Rn |
| 2 | Register indirect | @ERn |
| 3 | Register indirect with displacement | @(d:16,ERn)/@(d:24,ERn) |
| 4 | Register indirect with post-increment Register indirect with pre-decrement | @ERn+ @-ERn |
| 5 | Absolute address | @aa:8/@aa:16/@aa:24 |
| 6 | Immediate | #xx:8/#xx:16/#xx:32 |
| 7 | Program-counter relative | @(d:8,PC)/@(d:16,PC) |
| 8 | Memory indirect | @@aa:8 |

Register Direct—Rn

The register field of the instruction specifies an 8-, 16-, or 32-bit general register containing the operand. R0H to R7H and R0L to R7L can be specified as 8-bit registers. R0 to R7 and E0 to E7 can be specified as 16-bit registers. ER0 to ER7 can be specified as 32-bit registers.

Register Indirect—@ERn

The register field of the instruction code specifies an address register (ERn), the lower 24 bits of which contain the address of the operand on memory.

Register Indirect with Displacement—@(d:16, ERn) or @(d:24, ERn)

A 16-bit or 24-bit displacement contained in the instruction is added to an address register (ERn) specified by the register field of the instruction, and the lower 24 bits of the sum the address of a memory operand. A 16-bit displacement is sign-extended when added.

Register Indirect with Post-Increment or Pre-Decrement—@ERn+ or @-ERn

- Register indirect with post-increment—@ERn+

The register field of the instruction code specifies an address register (ERn) the lower 24 bits of which contains the address of a memory operand. After the operand is accessed, 1, 2, or 4 is added to the address register contents (32 bits) and the sum is stored in the address register.

The value added is 1 for byte access, 2 for word access, or 4 for longword access. For the word or longword access, the register value should be even.

- **Register indirect with pre-decrement—@-ERn**
The value 1, 2, or 4 is subtracted from an address register (ERn) specified by the register field in the instruction code, and the lower 24 bits of the result is the address of a memory operand. The result is also stored in the address register. The value subtracted is 1 for byte access, 2 for word access, or 4 for longword access. For the word or longword access, the register value should be even.

Absolute Address—@aa:8, @aa:16, @aa:24

The instruction code contains the absolute address of a memory operand. The absolute address may be 8 bits long (@aa:8), 16 bits long (@aa:16), 24 bits long (@aa:24)

For an 8-bit absolute address, the upper 16 bits are all assumed to be 1 (H'FFFF). For a 16-bit absolute address the upper 8 bits are a sign extension. A 24-bit absolute address can access the entire address space.

The access ranges of absolute addresses for the group of this LSI are those shown in table 2.11, because the upper 8 bits are ignored.

Table 2.11 Absolute Address Access Ranges

| Absolute Address | Access Range |
|-------------------------|---------------------|
| 8 bits (@aa:8) | H'FF00 to H'FFFF |
| 16 bits (@aa:16) | H'0000 to H'FFFF |
| 24 bits (@aa:24) | H'0000 to H'FFFF |

Immediate—#xx:8, #xx:16, or #xx:32

The instruction contains 8-bit (#xx:8), 16-bit (#xx:16), or 32-bit (#xx:32) immediate data as an operand.

The ADDS, SUBS, INC, and DEC instructions contain immediate data implicitly. Some bit manipulation instructions contain 3-bit immediate data in the instruction code, specifying a bit number. The TRAPA instruction contains 2-bit immediate data in its instruction code, specifying a vector address.

Program-Counter Relative—@(d:8, PC) or @(d:16, PC)

This mode is used in the BSR instruction. An 8-bit or 16-bit displacement contained in the instruction is sign-extended and added to the 24-bit PC contents to generate a branch address. The PC value to which the displacement is added is the address of the first byte of the next instruction,

so the possible branching range is -126 to $+128$ bytes (-63 to $+64$ words) or -32766 to $+32768$ bytes (-16383 to $+16384$ words) from the branch instruction. The resulting value should be an even number.

Memory Indirect—@@aa:8

This mode can be used by the JMP and JSR instructions. The instruction code contains an 8-bit absolute address specifying a memory operand. This memory operand contains a branch address. The memory operand is accessed by longword access. The first byte of the memory operand is ignored, generating a 24-bit branch address. Figure 2.8 shows how to specify branch address for in memory indirect mode. The upper bits of the absolute address are all assumed to be 0, so the address range is 0 to 255 (H'0000 to H'00FF).

Note that the first part of the address range is also the exception vector area.

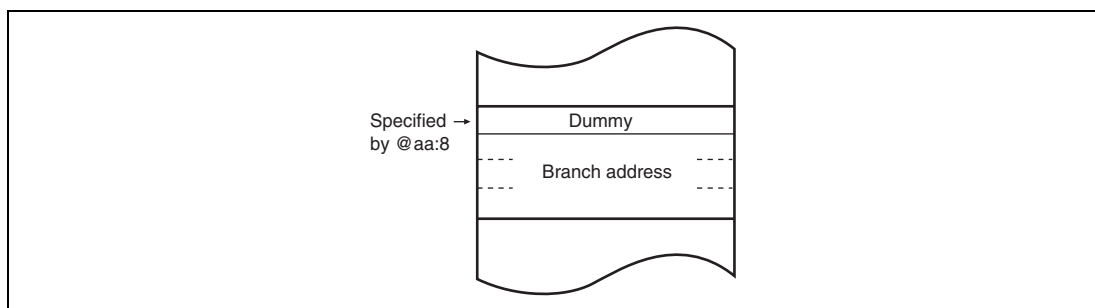

Figure 2.8 Branch Address Specification in Memory Indirect Mode

2.5.2 Effective Address Calculation

Table 2.12 indicates how effective addresses are calculated in each addressing mode. In this LSI the upper 8 bits of the effective address are ignored in order to generate a 16-bit effective address.

Table 2.12 Effective Address Calculation (1)







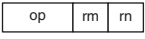
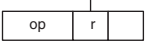
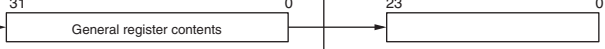
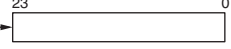

| No | Addressing Mode and Instruction Format | Effective Address Calculation | Effective Address (EA) |
|----|--|--|--|
| 1 | Register direct(Rn)  | | Operand is general register contents. |
| 2 | Register indirect(@ERn)  |  |  |
| 3 | Register indirect with displacement @d:(16,ERn) or @ (d:24,ERn)  |  |  |
| 4 | Register indirect with post-increment or pre-decrement •Register indirect with post-increment @ERn+  •Register indirect with pre-decrement @-ERn  |  <p>The value to be added or subtracted is 1 when the operand is byte size, 2 for word size, and 4 for longword size.</p> |   |

Table 2.12 Effective Address Calculation (2)

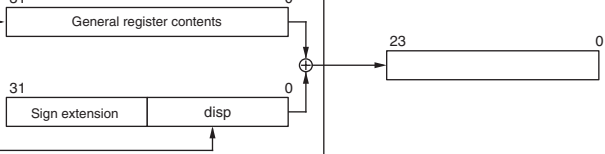
| No | Addressing Mode and Instruction Format | Effective Address Calculation | Effective Address (EA) |
|----|---|---|---|
| 5 | Absolute address @aa:8  | |  |
| | @aa:16  | |  |
| | @aa:24  | |  |
| 6 | Immediate #xx:8/#xx:16/#xx:32  | | Operand is immediate data. |
| 7 | Program-counter relative @(d:8,PC) @(d:16,PC)  |  |  |
| 8 | Memory indirect @aa:8  |  |  |

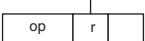
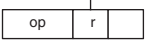
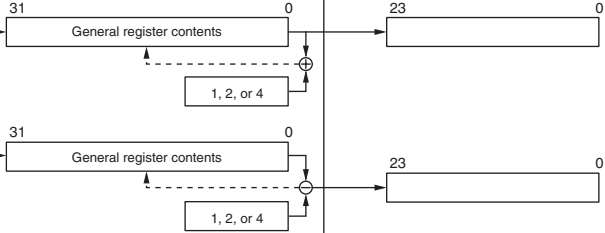
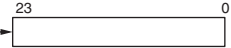
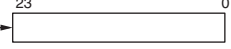
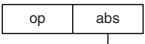
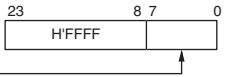
[Legend]

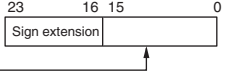
r, rm, rn: Register field
 op: Operation field
 disp: Displacement
 IMM: Immediate data
 abs: Absolute address

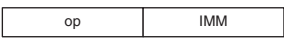
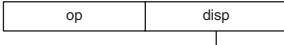
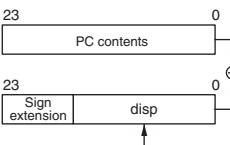
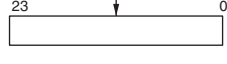
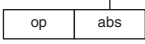
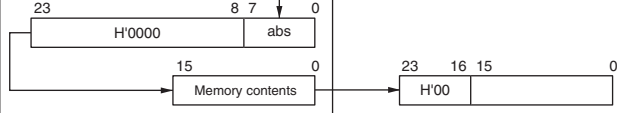
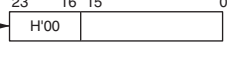
2.6 Basic Bus Cycle

CPU operation is synchronized by a system clock (ϕ) or a subclock (ϕ_{SUB}). The period from a rising edge of ϕ or ϕ_{SUB} to the next rising edge is called one state. A bus cycle consists of two states or three states. The cycle differs depending on whether access is to on-chip memory or to on-chip peripheral modules.

2.6.1 Access to On-Chip Memory (RAM, ROM)

Access to on-chip memory takes place in two states. The data bus width is 16 bits, allowing access in byte or word size. Figure 2.9 shows the on-chip memory access cycle.

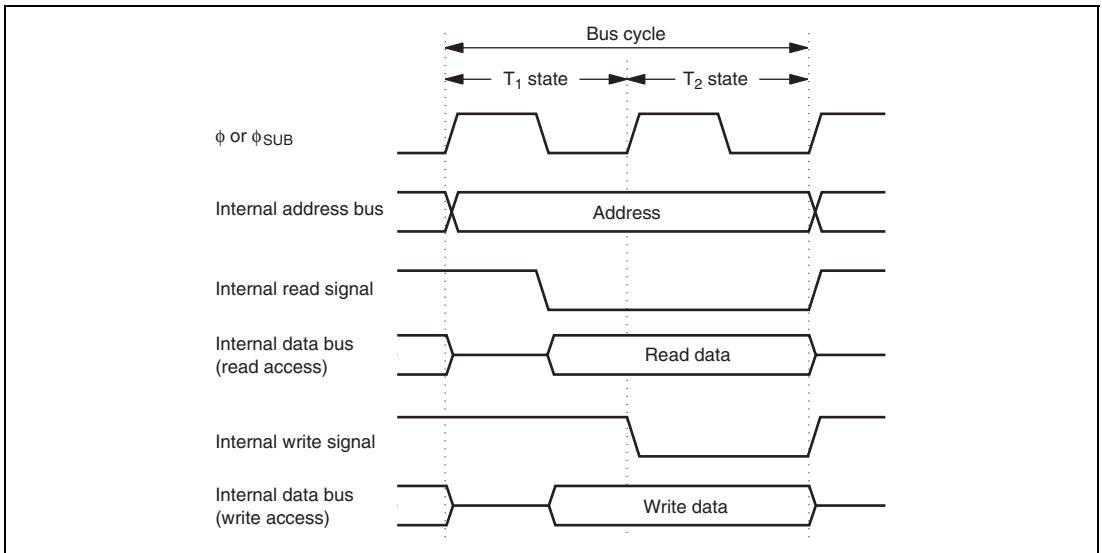

Figure 2.9 On-Chip Memory Access Cycle

2.6.2 On-Chip Peripheral Modules

On-chip peripheral modules are accessed in two states or three states. The data bus width is 8 bits or 16 bits depending on the register. For description on the data bus width and number of accessing states of each register, refer to section 20.1, Register Addresses (Address Order). Registers with 16-bit data bus width can be accessed by word size only. Registers with 8-bit data bus width can be accessed by byte or word size. When a register with 8-bit data bus width is accessed by word size, a bus cycle occurs twice. In two-state access, the operation timing is the same as that for on-chip memory.

Figure 2.10 shows the operation timing in the case of three-state access to an on-chip peripheral module.

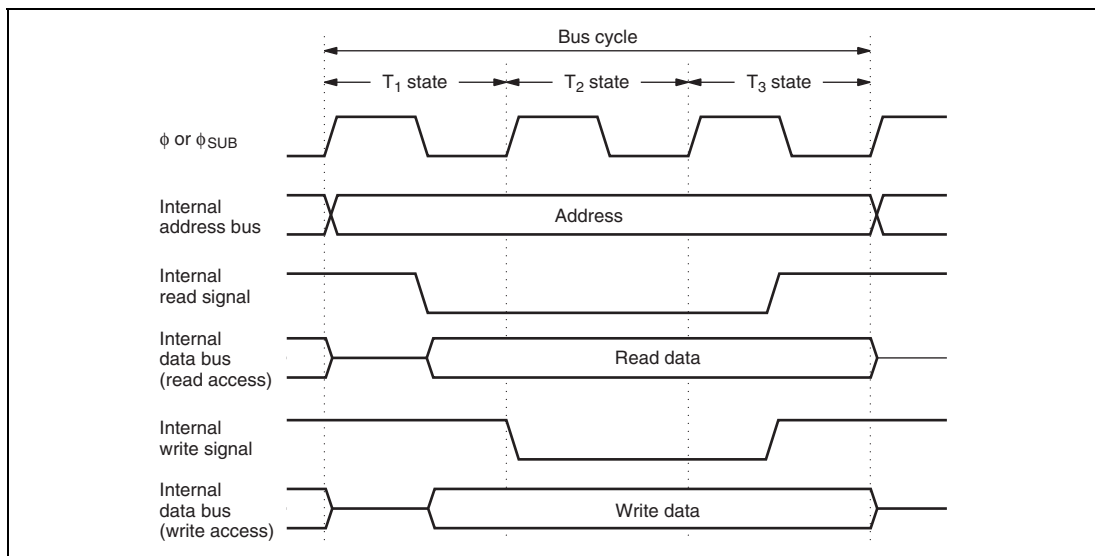

Figure 2.10 On-Chip Peripheral Module Access Cycle (3-State Access)

2.7 CPU States

There are four CPU states: the reset state, program execution state, program halt state, and exception-handling state. The program execution state includes active mode and subactive mode. For the program halt state there are a sleep mode, standby mode, and sub-sleep mode. These states are shown in figure 2.11. Figure 2.12 shows the state transitions. For details on program execution state and program halt state, refer to section 6, Power-Down Modes. For details on exception processing, refer to section 3, Exception Handling.

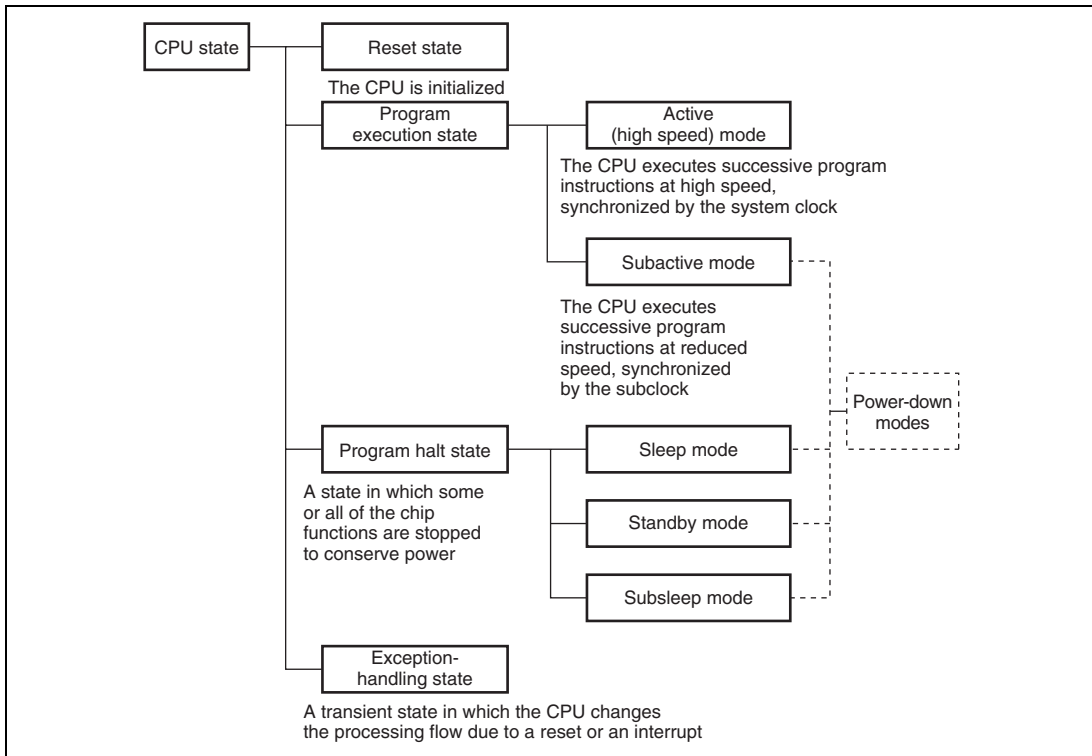

Figure 2.11 CPU Operation States

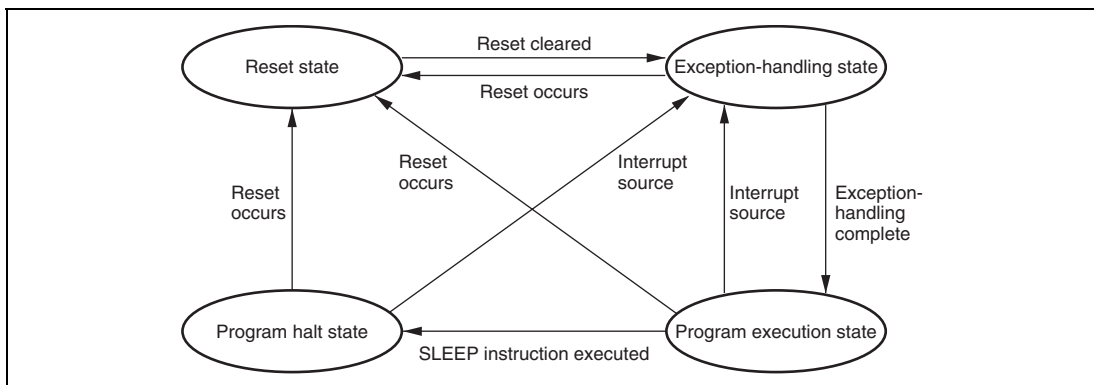

Figure 2.12 State Transitions

2.8 Usage Notes

2.8.1 Notes on Data Access to Empty Areas

The address space of this LSI includes empty areas in addition to the ROM, RAM, and on-chip I/O registers areas available to the user. When data is transferred from CPU to empty areas, the transferred data will be lost. This action may also cause the CPU to malfunction. When data is transferred from an empty area to CPU, the contents of the data cannot be guaranteed.

2.8.2 EEPMOV Instruction

EEPMOV is a block-transfer instruction and transfers the byte size of data indicated by R4L, which starts from the address indicated by R5, to the address indicated by R6. Set R4L and R6 so that the end address of the destination address (value of R6 + R4L) does not exceed H'FFFF (the value of R6 must not change from H'FFFF to H'0000 during execution).

2.8.3 Bit Manipulation Instruction

The BSET, BCLR, BNOT, BST, and BIST instructions read data from the specified address in byte units, manipulate the data of the target bit, and write data to the same address again in byte units. Special care is required when using these instructions in cases where two registers are assigned to the same address or when a bit is directly manipulated for a port or a register containing a write-only bit, because this may rewrite data of a bit other than the bit to be manipulated.

Bit manipulation for two registers assigned to the same address

Example 1: Bit manipulation for the timer load register and timer counter

(Applicable for timer B and timer C, not for the group of this LSI.)

Figure 2.13 shows an example of a timer in which two timer registers are assigned to the same address. When a bit manipulation instruction accesses the timer load register and timer counter of a reloadable timer, since these two registers share the same address, the following operations takes place.

1. Data is read in byte units.
2. The CPU sets or resets the bit to be manipulated with the bit manipulation instruction.
3. The written data is written again in byte units to the timer load register.

The timer is counting, so the value read is not necessarily the same as the value in the timer load register. As a result, bits other than the intended bit in the timer counter may be modified and the modified value may be written to the timer load register.

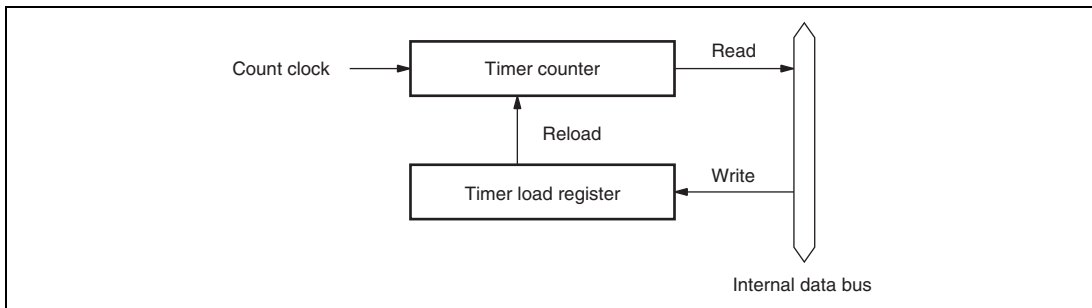

Figure 2.13 Example of Timer Configuration with Two Registers Allocated to Same Address

Example 2: The BSET instruction is executed for port 5.

P57 and P56 are input pins, with a low-level signal input at P57 and a high-level signal input at P56. P55 to P50 are output pins and output low-level signals. An example to output a high-level signal at P50 with a BSET instruction is shown below.

- Prior to executing BSET instruction

| | P57 | P56 | P55 | P54 | P53 | P52 | P51 | P50 |
|--------------|-----------|------------|-----------|-----------|-----------|-----------|-----------|-----------|
| Input/output | Input | Input | Output | Output | Output | Output | Output | Output |
| Pin state | Low level | High level | Low level | Low level | Low level | Low level | Low level | Low level |
| PCR5 | 0 | 0 | 1 | 1 | 1 | 1 | 1 | 1 |
| PDR5 | 1 | 0 | 0 | 0 | 0 | 0 | 0 | 0 |

- BSET instruction executed instruction

```
BSET #0, @PDR5
```

The BSET instruction is executed for port 5.

- After executing BSET instruction

| | P57 | P56 | P55 | P54 | P53 | P52 | P51 | P50 |
|--------------|-----------|------------|-----------|-----------|-----------|-----------|-----------|------------|
| Input/output | Input | Input | Output | Output | Output | Output | Output | Output |
| Pin state | Low level | High level | Low level | Low level | Low level | Low level | Low level | High level |
| PCR5 | 0 | 0 | 1 | 1 | 1 | 1 | 1 | 1 |
| PDR5 | 0 | 1 | 0 | 0 | 0 | 0 | 0 | 1 |

- Description on operation

1. When the BSET instruction is executed, first the CPU reads port 5.

Since P57 and P56 are input pins, the CPU reads the pin states (low-level and high-level input).

P55 to P50 are output pins, so the CPU reads the value in PDR5. In this example PDR5 has a value of H'80, but the value read by the CPU is H'40.

2. Next, the CPU sets bit 0 of the read data to 1, changing the PDR5 data to H'41.
3. Finally, the CPU writes H'41 to PDR5, completing execution of BSET instruction.

As a result of the BSET instruction, bit 0 in PDR5 becomes 1, and P50 outputs a high-level signal. However, bits 7 and 6 of PDR5 end up with different values. To prevent this problem, store a copy of the PDR5 data in a work area in memory. Perform the bit manipulation on the data in the work area, then write this data to PDR5.

- Prior to executing BSET instruction

```
MOV.B #80, R0L
MOV.B R0L, @RAM0
MOV.B R0L, @PDR5
```

The PDR5 value (H'80) is written to a work area in memory (RAM0) as well as to PDR5.

| | P57 | P56 | P55 | P54 | P53 | P52 | P51 | P50 |
|--------------|-----------|------------|-----------|-----------|-----------|-----------|-----------|-----------|
| Input/output | Input | Input | Output | Output | Output | Output | Output | Output |
| Pin state | Low level | High level | Low level | Low level | Low level | Low level | Low level | Low level |
| PCR5 | 0 | 0 | 1 | 1 | 1 | 1 | 1 | 1 |
| PDR5 | 1 | 0 | 0 | 0 | 0 | 0 | 0 | 0 |
| RAM0 | 1 | 0 | 0 | 0 | 0 | 0 | 0 | 0 |

- BSET instruction executed

```
BSET #0, @RAM0
```

The BSET instruction is executed designating the PDR5 work area (RAM0).

- After executing BSET instruction

```
MOV.B @RAM0, R0L
MOV.B R0L, @PDR5
```

The work area (RAM0) value is written to PDR5.

| | P57 | P56 | P55 | P54 | P53 | P52 | P51 | P50 |
|--------------|-----------|------------|-----------|-----------|-----------|-----------|-----------|------------|
| Input/output | Input | Input | Output | Output | Output | Output | Output | Output |
| Pin state | Low level | High level | Low level | Low level | Low level | Low level | Low level | High level |
| PCR5 | 0 | 0 | 1 | 1 | 1 | 1 | 1 | 1 |
| PDR5 | 1 | 0 | 0 | 0 | 0 | 0 | 0 | 1 |
| RAM0 | 1 | 0 | 0 | 0 | 0 | 0 | 0 | 1 |

Bit Manipulation in a Register Containing a Write-Only Bit

Example 3: BCLR instruction executed designating port 5 control register PCR5

P57 and P56 are input pins, with a low-level signal input at P57 and a high-level signal input at P56. P55 to P50 are output pins that output low-level signals. An example of setting the P50 pin as

an input pin by the BCLR instruction is shown below. It is assumed that a high-level signal will be input to this input pin.

- Prior to executing BCLR instruction

| | P57 | P56 | P55 | P54 | P53 | P52 | P51 | P50 |
|--------------|------------|------------|------------|------------|------------|------------|------------|------------|
| Input/output | Input | Input | Output | Output | Output | Output | Output | Output |
| Pin state | Low level | High level | Low level | Low level | Low level | Low level | Low level | Low level |
| PCR5 | 0 | 0 | 1 | 1 | 1 | 1 | 1 | 1 |
| PDR5 | 1 | 0 | 0 | 0 | 0 | 0 | 0 | 0 |

- BCLR instruction executed

```
BCLR #0, @PCR5
```

The BCLR instruction is executed for PCR5.

- After executing BCLR instruction

| | P57 | P56 | P55 | P54 | P53 | P52 | P51 | P50 |
|--------------|------------|------------|------------|------------|------------|------------|------------|------------|
| Input/output | Output | Output | Output | Output | Output | Output | Output | Input |
| Pin state | Low level | High level | Low level | Low level | Low level | Low level | Low level | High level |
| PCR5 | 1 | 1 | 1 | 1 | 1 | 1 | 1 | 0 |
| PDR5 | 1 | 0 | 0 | 0 | 0 | 0 | 0 | 0 |

- Description on operation

1. When the BCLR instruction is executed, first the CPU reads PCR5. Since PCR5 is a write-only register, the CPU reads a value of H'FF, even though the PCR5 value is actually H'3F.
2. Next, the CPU clears bit 0 in the read data to 0, changing the data to H'FE.
3. Finally, H'FE is written to PCR5 and BCLR instruction execution ends.

As a result of this operation, bit 0 in PCR5 becomes 0, making P50 an input port. However, bits 7 and 6 in PCR5 change to 1, so that P57 and P56 change from input pins to output pins. To prevent this problem, store a copy of the PDR5 data in a work area in memory and manipulate data of the bit in the work area, then write this data to PDR5.

- Prior to executing BCLR instruction

```
MOV.B #3F, R0L
MOV.B R0L, @RAM0
MOV.B R0L, @PCR5
```

The PCR5 value (H'3F) is written to a work area in memory (RAM0) as well as to PCR5.

| | P57 | P56 | P55 | P54 | P53 | P52 | P51 | P50 |
|--------------|-----------|------------|-----------|-----------|-----------|-----------|-----------|-----------|
| Input/output | Input | Input | Output | Output | Output | Output | Output | Output |
| Pin state | Low level | High level | Low level | Low level | Low level | Low level | Low level | Low level |
| PCR5 | 0 | 0 | 1 | 1 | 1 | 1 | 1 | 1 |
| PDR5 | 1 | 0 | 0 | 0 | 0 | 0 | 0 | 0 |
| RAM0 | 0 | 0 | 1 | 1 | 1 | 1 | 1 | 1 |

- BCLR instruction executed

```
BCLR #0, @RAM0
```

The BCLR instructions executed for the PCR5 work area (RAM0).

- After executing BCLR instruction

```
MOV.B @RAM0, R0L
MOV.B R0L, @PCR5
```

The work area (RAM0) value is written to PCR5.

| | P57 | P56 | P55 | P54 | P53 | P52 | P51 | P50 |
|--------------|-----------|------------|-----------|-----------|-----------|-----------|-----------|------------|
| Input/output | Input | Input | Output | Output | Output | Output | Output | Output |
| Pin state | Low level | High level | Low level | Low level | Low level | Low level | Low level | High level |
| PCR5 | 0 | 0 | 1 | 1 | 1 | 1 | 1 | 0 |
| PDR5 | 1 | 0 | 0 | 0 | 0 | 0 | 0 | 0 |
| RAM0 | 0 | 0 | 1 | 1 | 1 | 1 | 1 | 0 |

Section 3 Exception Handling

Exception handling may be caused by a reset, a trap instruction (TRAPA), or interrupts.

- Reset

A reset has the highest exception priority. Exception handling starts as soon as the reset is cleared by the $\overline{\text{RES}}$ pin. The chip is also reset when the watchdog timer overflows, and exception handling starts. Exception handling is the same as exception handling by the $\overline{\text{RES}}$ pin.

- Trap Instruction

Exception handling starts when a trap instruction (TRAPA) is executed. The TRAPA instruction generates a vector address corresponding to a vector number from 0 to 3, as specified in the instruction code. Exception handling can be executed at all times in the program execution state, regardless of the setting of the I bit in CCR.

- Interrupts

External interrupts other than NMI and internal interrupts other than address break are masked by the I bit in CCR, and kept masked while the I bit is set to 1. Exception handling starts when the current instruction or exception handling ends, if an interrupt request has been issued.

3.1 Exception Sources and Vector Address

Table 3.1 shows the vector addresses and priority of each exception handling. When more than one interrupt is requested, handling is performed from the interrupt with the highest priority.

Table 3.1 Exception Sources and Vector Address

| Relative Module | Exception Sources | Vector Number | Vector Address | Priority |
|---|----------------------------|---------------|------------------|---------------|
| $\overline{\text{RES}}$ pin Watchdog timer | Reset | 0 | H'0000 to H'0001 | High |
| — | Reserved for system use | 1 to 6 | H'0002 to H'000D | ↑ ↓ Low |
| External interrupt pin | NMI | 7 | H'000E to H'000F | |
| CPU | Trap instruction (#0) | 8 | H'0010 to H'0011 | |
| | (#1) | 9 | H'0012 to H'0013 | |
| | (#2) | 10 | H'0014 to H'0015 | |
| | (#3) | 11 | H'0016 to H'0017 | |
| Address break | Break conditions satisfied | 12 | H'0018 to H'0019 | Low |

3.2 Register Descriptions

Interrupts are controlled by the following registers.

- Interrupt edge select register 1 (IEGR1)
- Interrupt edge select register 2 (IEGR2)
- Interrupt enable register 1 (IENR1)
- Interrupt flag register 1 (IRR1)
- Wakeup interrupt flag register (IWPR)

3.2.1 Interrupt Edge Select Register 1 (IEGR1)

IEGR1 selects the direction of an edge that generates interrupt requests of pins $\overline{\text{NMI}}$ and $\overline{\text{IRQ3}}$ to $\overline{\text{IRQ0}}$.

| Bit | Bit Name | Initial Value | R/W | Description |
|--------|----------|---------------|-----|---|
| 7 | NMIEG | 0 | R/W | NMI Edge Select 0: Falling edge of $\overline{\text{NMI}}$ pin input is detected 1: Rising edge of $\overline{\text{NMI}}$ pin input is detected |
| 6 to 4 | — | All 1 | — | Reserved These bits are always read as 1. |
| 3 | IEG3 | 0 | R/W | IRQ3 Edge Select 0: Falling edge of $\overline{\text{IRQ3}}$ pin input is detected 1: Rising edge of $\overline{\text{IRQ3}}$ pin input is detected |
| 2 | IEG2 | 0 | R/W | IRQ2 Edge Select 0: Falling edge of $\overline{\text{IRQ2}}$ pin input is detected 1: Rising edge of $\overline{\text{IRQ2}}$ pin input is detected |
| 1 | IEG1 | 0 | R/W | IRQ1 Edge Select 0: Falling edge of $\overline{\text{IRQ1}}$ pin input is detected 1: Rising edge of $\overline{\text{IRQ1}}$ pin input is detected |
| 0 | IEG0 | 0 | R/W | IRQ0 Edge Select 0: Falling edge of $\overline{\text{IRQ0}}$ pin input is detected 1: Rising edge of $\overline{\text{IRQ0}}$ pin input is detected |

3.2.2 Interrupt Edge Select Register 2 (IEGR2)

IEGR2 selects the direction of an edge that generates interrupt requests of the pins $\overline{\text{ADTRG}}$ and $\overline{\text{WKP5}}$ to $\overline{\text{WKP0}}$.

| Bit | Bit Name | Initial Value | R/W | Description |
|------|----------|---------------|-----|---|
| 7, 6 | — | All 1 | — | Reserved These bits are always read as 1. |
| 5 | WPEG5 | 0 | R/W | WKP5 Edge Select 0: Falling edge of $\overline{\text{WKP5(ADTRG)}}$ pin input is detected 1: Rising edge of $\overline{\text{WKP5(ADTRG)}}$ pin input is detected |
| 4 | WPEG4 | 0 | R/W | WKP4 Edge Select 0: Falling edge of $\overline{\text{WKP4}}$ pin input is detected 1: Rising edge of $\overline{\text{WKP4}}$ pin input is detected |
| 3 | WPEG3 | 0 | R/W | WKP3 Edge Select 0: Falling edge of $\overline{\text{WKP3}}$ pin input is detected 1: Rising edge of $\overline{\text{WKP3}}$ pin input is detected |
| 2 | WPEG2 | 0 | R/W | WKP2 Edge Select 0: Falling edge of $\overline{\text{WKP2}}$ pin input is detected 1: Rising edge of $\overline{\text{WKP2}}$ pin input is detected |
| 1 | WPEG1 | 0 | R/W | WKP1 Edge Select 0: Falling edge of $\overline{\text{WKP1}}$ pin input is detected 1: Rising edge of $\overline{\text{WKP1}}$ pin input is detected |
| 0 | WPEG0 | 0 | R/W | WKP0 Edge Select 0: Falling edge of $\overline{\text{WKP0}}$ pin input is detected 1: Rising edge of $\overline{\text{WKP0}}$ pin input is detected |

3.2.3 Interrupt Enable Register 1 (IENR1)

IENR1 enables direct transition interrupts, timer A overflow interrupts, and external pin interrupts.

| Bit | Bit Name | Initial Value | R/W | Description |
|-----|----------|---------------|-----|--|
| 7 | IENDT | 0 | R/W | Direct Transfer Interrupt Enable When this bit is set to 1, direct transition interrupt requests are enabled. |
| 6 | IENTA | 0 | R/W | Timer A Interrupt Enable When this bit is set to 1, timer A overflow interrupt requests are enabled. |
| 5 | IENWP | 0 | R/W | Wakeup Interrupt Enable This bit is an enable bit, which is common to the pins $\overline{WKP5}$ to $\overline{WKP0}$. When the bit is set to 1, interrupt requests are enabled. |
| 4 | — | 1 | — | Reserved This bit is always read as 1. |
| 3 | IEN3 | 0 | R/W | IRQ3 Interrupt Enable When this bit is set to 1, interrupt requests of the $\overline{IRQ3}$ pin are enabled. |
| 2 | IEN2 | 0 | R/W | IRQ2 Interrupt Enable When this bit is set to 1, interrupt requests of the $\overline{IRQ2}$ pin are enabled. |
| 1 | IEN1 | 0 | R/W | IRQ1 Interrupt Enable When this bit is set to 1, interrupt requests of the $\overline{IRQ1}$ pin are enabled. |
| 0 | IEN0 | 0 | R/W | IRQ0 Interrupt Enable When this bit is set to 1, interrupt requests of the $\overline{IRQ0}$ pin are enabled. |

When disabling interrupts by clearing bits in an interrupt enable register, or when clearing bits in an interrupt flag register, always do so while interrupts are masked ($I = 1$). If the above clear operations are performed while $I = 0$, and as a result a conflict arises between the clear instruction and an interrupt request, exception handling for the interrupt will be executed after the clear instruction has been executed.

3.2.4 Interrupt Flag Register 1 (IRR1)

IRR1 is a status flag register for direct transition interrupts, timer A overflow interrupts, and $\overline{\text{IRQ3}}$ to $\overline{\text{IRQ0}}$ interrupt requests.

| Bit | Bit Name | Initial Value | R/W | Description |
|------|----------|---------------|-----|---|
| 7 | IRRDT | 0 | R/W | Direct Transfer Interrupt Request Flag [Setting condition] When a direct transfer is made by executing a SLEEP instruction while DTON in SYSCR2 is set to 1. [Clearing condition] When IRRDT is cleared by writing 0 |
| 6 | IRRATA | 0 | R/W | Timer A Interrupt Request Flag [Setting condition] When the timer A counter value overflows [Clearing condition] When IRRATA is cleared by writing 0 |
| 5, 4 | — | All 1 | — | Reserved These bits are always read as 1. |
| 3 | IRRI3 | 0 | R/W | IRQ3 Interrupt Request Flag [Setting condition] When $\overline{\text{IRQ3}}$ pin is designated for interrupt input and the designated signal edge is detected. [Clearing condition] When IRRI3 is cleared by writing 0 |
| 2 | IRRI2 | 0 | R/W | IRQ2 Interrupt Request Flag [Setting condition] When $\overline{\text{IRQ2}}$ pin is designated for interrupt input and the designated signal edge is detected. [Clearing condition] When IRRI2 is cleared by writing 0 |
| 1 | IRRI1 | 0 | R/W | IRQ1 Interrupt Request Flag [Setting condition] When $\overline{\text{IRQ1}}$ pin is designated for interrupt input and the designated signal edge is detected. [Clearing condition] When IRRI1 is cleared by writing 0 |

| Bit | Bit Name | Initial Value | R/W | Description |
|-----|----------|---------------|-----|---|
| 0 | IRRI0 | 0 | R/W | <p>IRQ0 Interrupt Request Flag</p> <p>[Setting condition]</p> <p>When $\overline{\text{IRQ0}}$ pin is designated for interrupt input and the designated signal edge is detected.</p> <p>[Clearing condition]</p> <p>When IRRI0 is cleared by writing 0</p> |

3.2.5 Wakeup Interrupt Flag Register (IWPR)

IWPR is a status flag register for $\overline{\text{WKP5}}$ to $\overline{\text{WKP0}}$ interrupt requests.

| Bit | Bit Name | Initial Value | R/W | Description |
|------|----------|---------------|-----|--|
| 7, 6 | — | All 1 | — | <p>Reserved</p> <p>These bits are always read as 1.</p> |
| 5 | IWPF5 | 0 | R/W | <p>WKP5 Interrupt Request Flag</p> <p>[Setting condition]</p> <p>When $\overline{\text{WKP5}}$ pin is designated for interrupt input and the designated signal edge is detected.</p> <p>[Clearing condition]</p> <p>When IWPF5 is cleared by writing 0.</p> |
| 4 | IWPF4 | 0 | R/W | <p>WKP4 Interrupt Request Flag</p> <p>[Setting condition]</p> <p>When $\overline{\text{WKP4}}$ pin is designated for interrupt input and the designated signal edge is detected.</p> <p>[Clearing condition]</p> <p>When IWPF4 is cleared by writing 0.</p> |
| 3 | IWPF3 | 0 | R/W | <p>WKP3 Interrupt Request Flag</p> <p>[Setting condition]</p> <p>When $\overline{\text{WKP3}}$ pin is designated for interrupt input and the designated signal edge is detected.</p> <p>[Clearing condition]</p> <p>When IWPF3 is cleared by writing 0.</p> |

| Bit | Bit Name | Initial Value | R/W | Description |
|-----|----------|---------------|-----|--|
| 2 | IWPF2 | 0 | R/W | <p>WKP2 Interrupt Request Flag</p> <p>[Setting condition]</p> <p>When $\overline{\text{WKP2}}$ pin is designated for interrupt input and the designated signal edge is detected.</p> <p>[Clearing condition]</p> <p>When IWPF2 is cleared by writing 0.</p> |
| 1 | IWPF1 | 0 | R/W | <p>WKP1 Interrupt Request Flag</p> <p>[Setting condition]</p> <p>When $\overline{\text{WKP1}}$ pin is designated for interrupt input and the designated signal edge is detected.</p> <p>[Clearing condition]</p> <p>When IWPF1 is cleared by writing 0.</p> |
| 0 | IWPF0 | 0 | R/W | <p>WKP0 Interrupt Request Flag</p> <p>[Setting condition]</p> <p>When $\overline{\text{WKP0}}$ pin is designated for interrupt input and the designated signal edge is detected.</p> <p>[Clearing condition]</p> <p>When IWPF0 is cleared by writing 0.</p> |

3.3 Reset Exception Handling

When the $\overline{\text{RES}}$ pin goes low, all processing halts and this LSI enters the reset. The internal state of the CPU and the registers of the on-chip peripheral modules are initialized by the reset. To ensure that this LSI is reset at power-up, hold the $\overline{\text{RES}}$ pin low until the clock pulse generator output stabilizes. To reset the chip during operation, hold the $\overline{\text{RES}}$ pin low for at least 10 system clock cycles. When the $\overline{\text{RES}}$ pin goes high after being held low for the necessary time, this LSI starts reset exception handling. The reset exception handling sequence is shown in figure 3.1.

The reset exception handling sequence is as follows. However, for the reset exception handling sequence of the product with on-chip power-on reset circuit, refer to section 18, Power-On Reset and Low-Voltage Detection Circuits (Optional).

1. Set the I bit in the condition code register (CCR) to 1.
2. The CPU generates a reset exception handling vector address (from H'0000 to H'0001), the data in that address is sent to the program counter (PC) as the start address, and program execution starts from that address.

3.4 Interrupt Exception Handling

3.4.1 External Interrupts

As the external interrupts, there are NMI, IRQ3 to IRQ0, and WKP5 to WKP0 interrupts.

NMI Interrupt

NMI interrupt is requested by input signal edge to pin $\overline{\text{NMI}}$. This interrupt is detected by either rising edge sensing or falling edge sensing, depending on the setting of bit NMIEG in IEGR1.

NMI is the highest-priority interrupt, and can always be accepted without depending on the I bit value in CCR.

IRQ3 to IRQ0 Interrupts

IRQ3 to IRQ0 interrupts are requested by input signals to pins $\overline{\text{IRQ3}}$ to $\overline{\text{IRQ0}}$. These four interrupts are given different vector addresses, and are detected individually by either rising edge sensing or falling edge sensing, depending on the settings of bits IEG3 to IEG0 in IEGR1.

When pins $\overline{\text{IRQ3}}$ to $\overline{\text{IRQ0}}$ are designated for interrupt input in PMR1 and the designated signal edge is input, the corresponding bit in IRR1 is set to 1, requesting the CPU of an interrupt.

These interrupts can be masked by setting bits IEN3 to IEN0 in IENR1.

WKP5 to WKP0 Interrupts

WKP5 to WKP0 interrupts are requested by input signals to pins $\overline{\text{WKP5}}$ to $\overline{\text{WKP0}}$. These six interrupts have the same vector addresses, and are detected individually by either rising edge sensing or falling edge sensing, depending on the settings of bits WPEG5 to WPEG0 in IEGR2.

When pins $\overline{\text{WKP5}}$ to $\overline{\text{WKP0}}$ are designated for interrupt input in PMR5 and the designated signal edge is input, the corresponding bit in IWPR is set to 1, requesting the CPU of an interrupt. These interrupts can be masked by setting bit IENWP in IENR1.

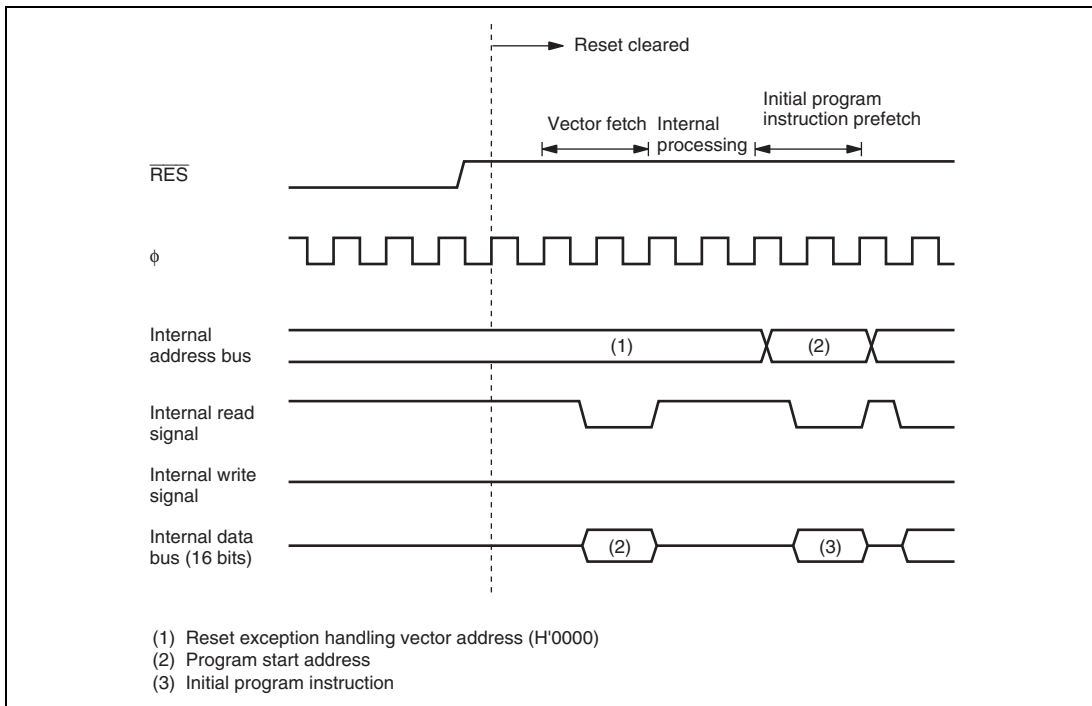

Figure 3.1 Reset Sequence

3.4.2 Internal Interrupts

Each on-chip peripheral module has a flag to show the interrupt request status and the enable bit to enable or disable the interrupt. For timer A interrupt requests and direct transfer interrupt requests generated by execution of a SLEEP instruction, this function is included in IRR1 and IENR1.

When an on-chip peripheral module requests an interrupt, the corresponding interrupt request status flag is set to 1, requesting the CPU of an interrupt. These interrupts can be masked by writing 0 to clear the corresponding enable bit.

3.4.3 Interrupt Handling Sequence

Interrupts are controlled by an interrupt controller.

Interrupt operation is described as follows.

1. If an interrupt occurs while the NMI or interrupt enable bit is set to 1, an interrupt request signal is sent to the interrupt controller.

2. When multiple interrupt requests are generated, the interrupt controller requests to the CPU for the interrupt handling with the highest priority at that time according to table 3.1. Other interrupt requests are held pending.
3. The CPU accepts the NMI and address break without depending on the I bit value. Other interrupt requests are accepted, if the I bit is cleared to 0 in CCR; if the I bit is set to 1, the interrupt request is held pending.
4. If the CPU accepts the interrupt after processing of the current instruction is completed, interrupt exception handling will begin. First, both PC and CCR are pushed onto the stack. The state of the stack at this time is shown in figure 3.2. The PC value pushed onto the stack is the address of the first instruction to be executed upon return from interrupt handling.
5. Then, the I bit of CCR is set to 1, masking further interrupts excluding the NMI and address break. Upon return from interrupt handling, the values of I bit and other bits in CCR will be restored and returned to the values prior to the start of interrupt exception handling.
6. Next, the CPU generates the vector address corresponding to the accepted interrupt, and transfers the address to PC as a start address of the interrupt handling-routine. Then a program starts executing from the address indicated in PC.

Figure 3.3 shows a typical interrupt sequence where the program area is in the on-chip ROM and the stack area is in the on-chip RAM.

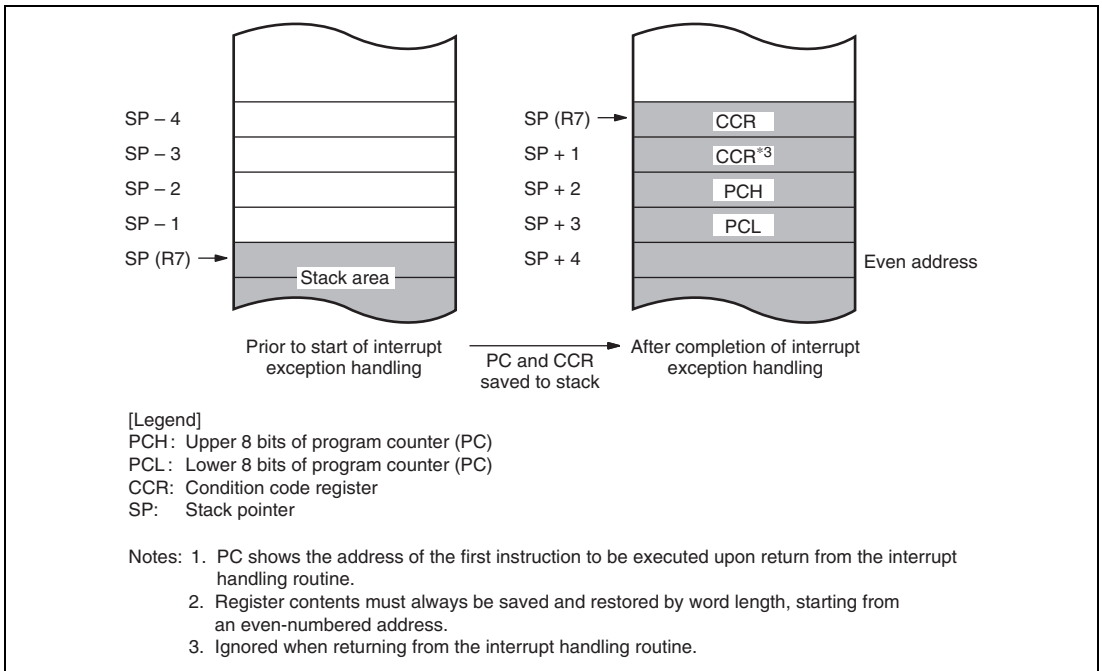

Figure 3.2 Stack Status after Exception Handling

3.4.4 Interrupt Response Time

Table 3.2 shows the number of wait states after an interrupt request flag is set until the first instruction of the interrupt handling-routine is executed.

Table 3.2 Interrupt Wait States

| Item | States | Total |
|---|---------|----------|
| Waiting time for completion of executing instruction* | 1 to 23 | 15 to 37 |
| Saving of PC and CCR to stack | 4 | |
| Vector fetch | 2 | |
| Instruction fetch | 4 | |
| Internal processing | 4 | |

Note: * Not including EEPMOV instruction.

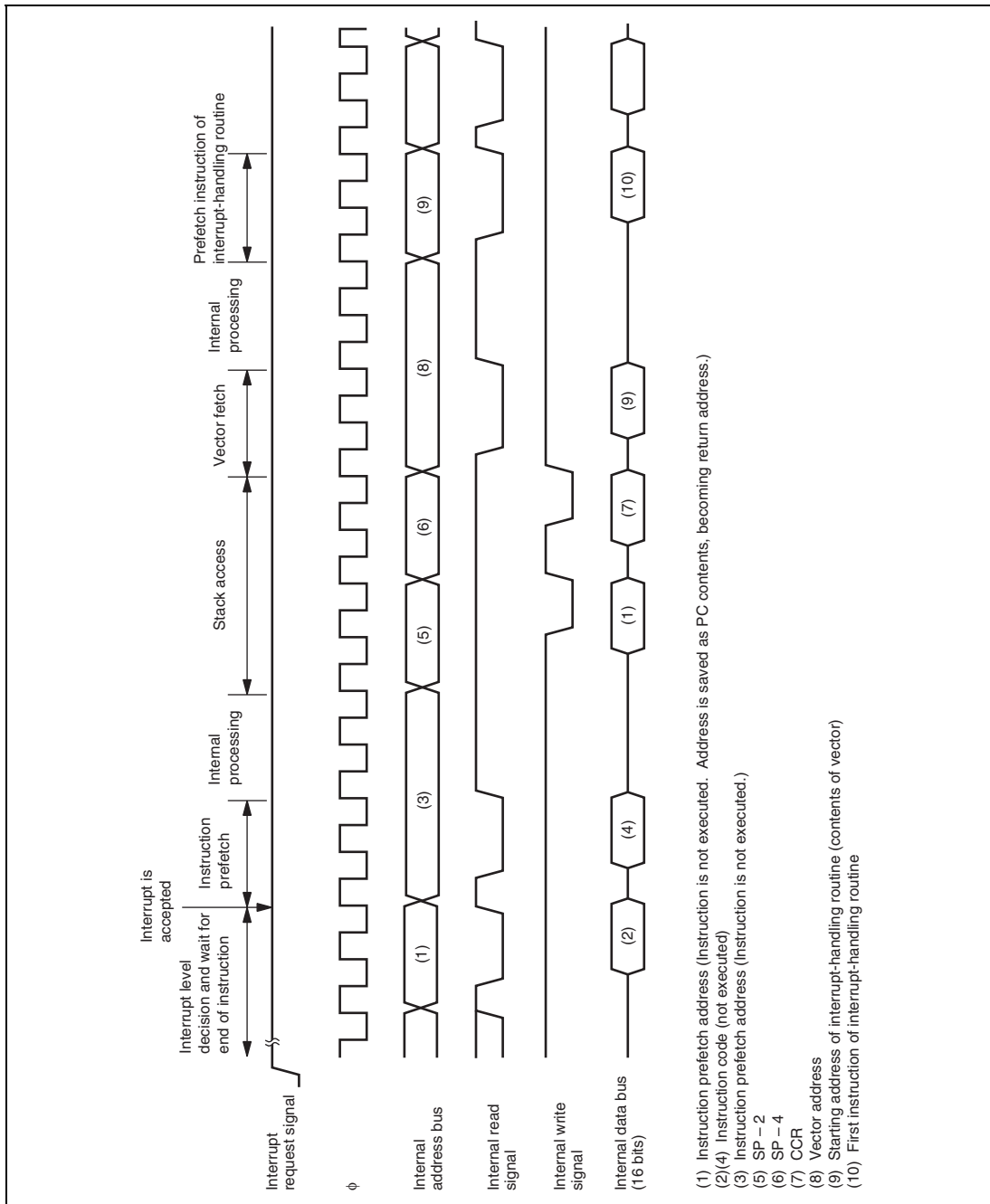

Figure 3.3 Interrupt Sequence

3.5 Usage Notes

3.5.1 Interrupts after Reset

If an interrupt is accepted after a reset and before the stack pointer (SP) is initialized, the PC and CCR will not be saved correctly, leading to a program crash. To prevent this, all interrupt requests, including NMI, are disabled immediately after a reset. Since the first instruction of a program is always executed immediately after the reset state ends, make sure that this instruction initializes the stack pointer (example: `MOV.W #xx: 16, SP`).

3.5.2 Notes on Stack Area Use

When word data is accessed, the least significant bit of the address is regarded as 0. Access to the stack always takes place in word size, so the stack pointer (SP: R7) should never indicate an odd address. Use `PUSH Rn (MOV.W Rn, @-SP)` or `POP Rn (MOV.W @SP+, Rn)` to save or restore register values.

3.5.3 Notes on Rewriting Port Mode Registers

When a port mode register is rewritten to switch the functions of external interrupt pins, $\overline{\text{IRQ3}}$ to $\overline{\text{IRQ0}}$, and $\overline{\text{WKP5}}$ to $\overline{\text{WKP0}}$, the interrupt request flag may be set to 1.

When switching a pin function, mask the interrupt before setting the bit in the port mode register. After accessing the port mode register, execute at least one instruction (e.g., `NOP`), then clear the interrupt request flag from 1 to 0.

Figure 3.4 shows a port mode register setting and interrupt request flag clearing procedure.

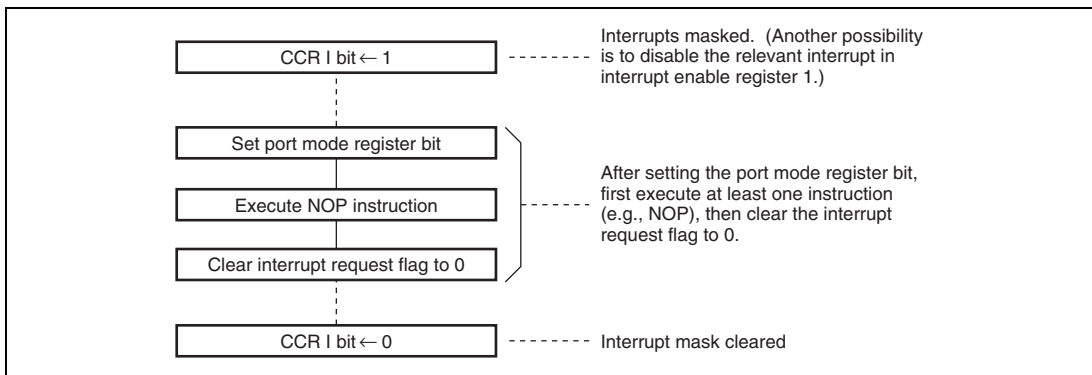

Figure 3.4 Port Mode Register Setting and Interrupt Request Flag Clearing Procedure

Section 4 Address Break

The address break simplifies on-board program debugging. It requests an address break interrupt when the set break condition is satisfied. The interrupt request is not affected by the I bit of CCR. Break conditions that can be set include instruction execution at a specific address and a combination of access and data at a specific address. With the address break function, the execution start point of a program containing a bug is detected and execution is branched to the correcting program. Figure 4.1 shows a block diagram of the address break.

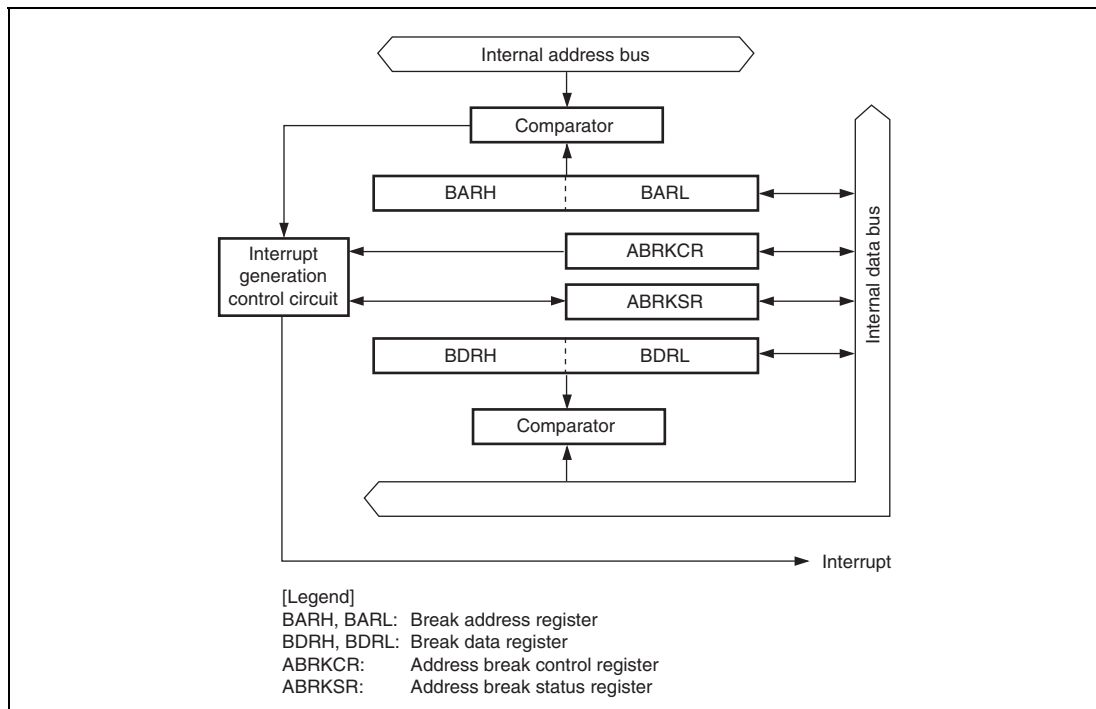

Figure 4.1 Block Diagram of Address Break

4.1 Register Descriptions

Address break has the following registers.

- Address break control register (ABRKCR)
- Address break status register (ABRKSR)
- Break address register (BARH, BARL)
- Break data register (BDRH, BDRL)

4.1.1 Address Break Control Register (ABRKCR)

ABRKCR sets address break conditions.

| Bit | Bit Name | Initial Value | R/W | Description |
|-----|----------|---------------|-----|---|
| 7 | RTINTE | 1 | R/W | RTE Interrupt Enable When this bit is 0, the interrupt immediately after executing RTE is masked and then one instruction must be executed. When this bit is 1, the interrupt is not masked. |
| 6 | CSEL1 | 0 | R/W | Condition Select 1 and 0 |
| 5 | CSEL0 | 0 | R/W | These bits set address break conditions. 00: Instruction execution cycle 01: CPU data read cycle 10: CPU data write cycle 11: CPU data read/write cycle |
| 4 | ACMP2 | 0 | R/W | Address Compare Condition Select 2 to 0 |
| 3 | ACMP1 | 0 | R/W | These bits set the comparison condition between the address set in BAR and the internal address bus. |
| 2 | ACMP0 | 0 | R/W | 000: Compares 16-bit addresses 001: Compares upper 12-bit addresses 010: Compares upper 8-bit addresses 011: Compares upper 4-bit addresses 1XX: Reserved (setting prohibited) |
| 1 | DCMP1 | 0 | R/W | Data Compare Condition Select 1 and 0 |
| 0 | DCMP0 | 0 | R/W | These bits set the comparison condition between the data set in BDR and the internal data bus. 00: No data comparison 01: Compares lower 8-bit data between BDRL and data bus 10: Compares upper 8-bit data between BDRH and data bus 11: Compares 16-bit data between BDR and data bus |

Legend: X: Don't care.

When an address break is set in the data read cycle or data write cycle, the data bus used will depend on the combination of the byte/word access and address. Table 4.1 shows the access and data bus used. When an I/O register space with an 8-bit data bus width is accessed in word size, a byte access is generated twice. For details on data widths of each register, see section 20.1, Register Addresses (Address Order).

Table 4.1 Access and Data Bus Used

| | Word Access | | Byte Access | |
|---|--------------|--------------|--------------|--------------|
| | Even Address | Odd Address | Even Address | Odd Address |
| ROM space | Upper 8 bits | Lower 8 bits | Upper 8 bits | Upper 8 bits |
| RAM space | Upper 8 bits | Lower 8 bits | Upper 8 bits | Upper 8 bits |
| I/O register with 8-bit data bus width | Upper 8 bits | Upper 8 bits | Upper 8 bits | Upper 8 bits |
| I/O register with 16-bit data bus width | Upper 8 bits | Lower 8 bits | — | — |

4.1.2 Address Break Status Register (ABRKSR)

ABRKSR consists of the address break interrupt flag and the address break interrupt enable bit.

| Bit | Bit Name | Initial Value | R/W | Description |
|--------|----------|---------------|-----|--|
| 7 | ABIF | 0 | R/W | Address Break Interrupt Flag [Setting condition] When the condition set in ABRKCR is satisfied [Clearing condition] When 0 is written after ABIF=1 is read |
| 6 | ABIE | 0 | R/W | Address Break Interrupt Enable When this bit is 1, an address break interrupt request is enabled. |
| 5 to 0 | — | All 1 | — | Reserved These bits are always read as 1. |

4.1.3 Break Address Registers (BARH, BARL)

BARH and BARL are 16-bit read/write registers that set the address for generating an address break interrupt. When setting the address break condition to the instruction execution cycle, set the first byte address of the instruction. The initial value of this register is H'FFFF.

4.1.4 Break Data Registers (BDRH, BDRL)

BDRH and BDRL are 16-bit read/write registers that set the data for generating an address break interrupt. BDRH is compared with the upper 8-bit data bus. BDRL is compared with the lower 8-bit data bus. When memory or registers are accessed by byte, the upper 8-bit data bus is used for even and odd addresses in the data transmission. Therefore, comparison data must be set in BDRH for byte access. For word access, the data bus used depends on the address. See section 4.1.1, Address Break Control Register (ABRKCR), for details. The initial value of this register is undefined.

4.2 Operation

When the ABIF and ABIE bits in ABRKSR are set to 1, the address break function generates an interrupt request to the CPU. The ABIF bit in ABRKSR is set to 1 by the combination of the address set in BAR, the data set in BDR, and the conditions set in ABRKCR. When the interrupt request is accepted, interrupt exception handling starts after the instruction being executed ends. The address break interrupt is not masked by the I bit in CCR of the CPU.

Figures 4.2 show the operation examples of the address break interrupt setting.

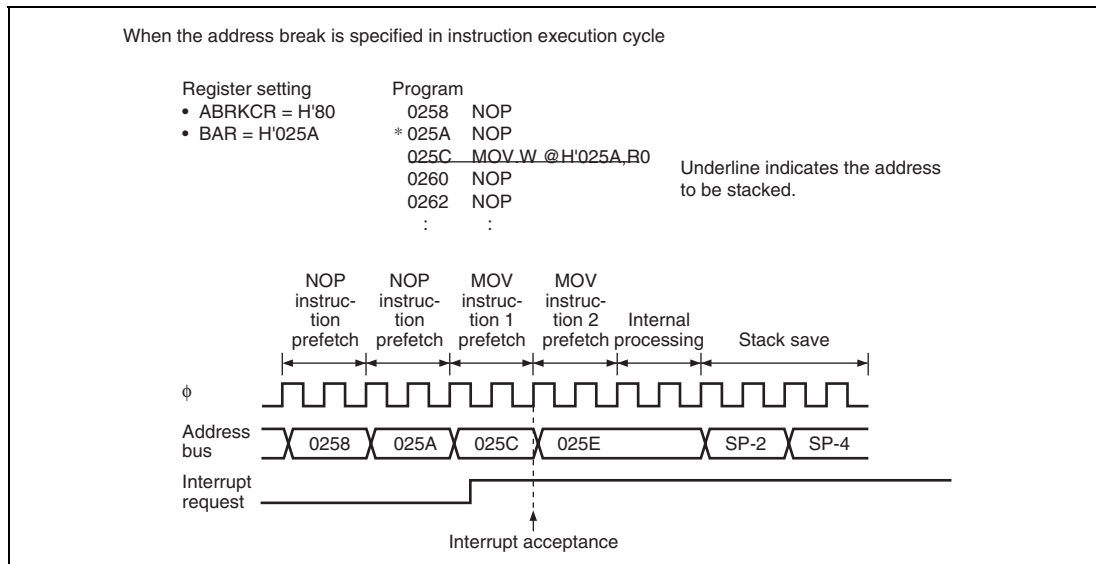

Figure 4.2 Address Break Interrupt Operation Example (1)

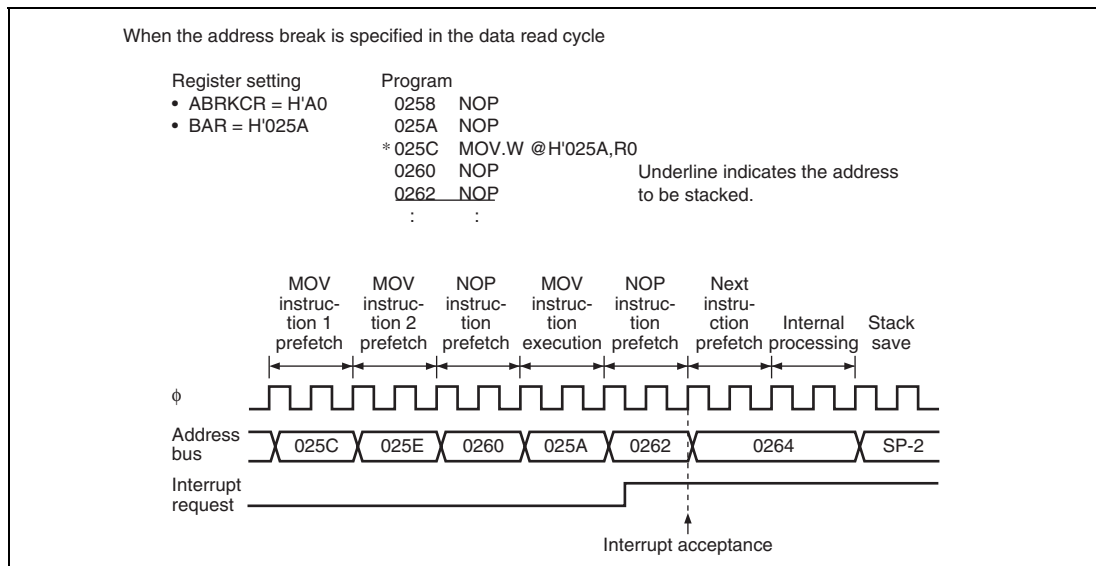

Figure 4.2 Address Break Interrupt Operation Example (2)

Section 5 Clock Pulse Generators

Clock oscillator circuitry (CPG: clock pulse generator) is provided on-chip, including both a system clock pulse generator and a subclock pulse generator. The system clock pulse generator consists of a system clock oscillator, a duty correction circuit, and system clock dividers. The subclock pulse generator consists of a subclock oscillator circuit and a subclock divider.

Figure 5.1 shows a block diagram of the clock pulse generators.

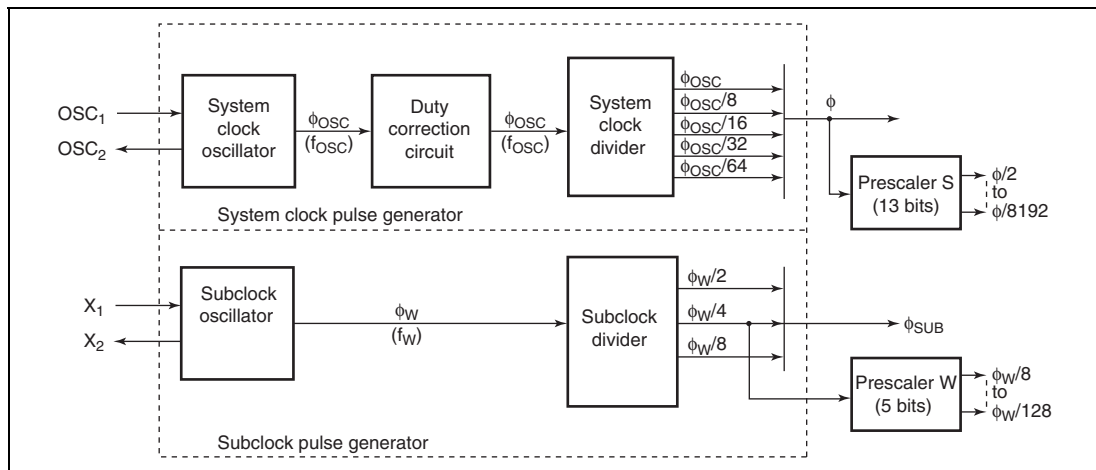

Figure 5.1 Block Diagram of Clock Pulse Generators

The basic clock signals that drive the CPU and on-chip peripheral modules are ϕ and ϕ_{SUB} . The system clock is divided by prescaler S to become a clock signal from $\phi/8192$ to $\phi/2$, and the subclock is divided by prescaler W to become a clock signal from $\phi_W/128$ to $\phi_W/8$. Both the system clock and subclock signals are provided to the on-chip peripheral modules.

5.1 System Clock Generator

Clock pulses can be supplied to the system clock divider either by connecting a crystal or ceramic resonator, or by providing external clock input. Figure 5.2 shows a block diagram of the system clock generator.

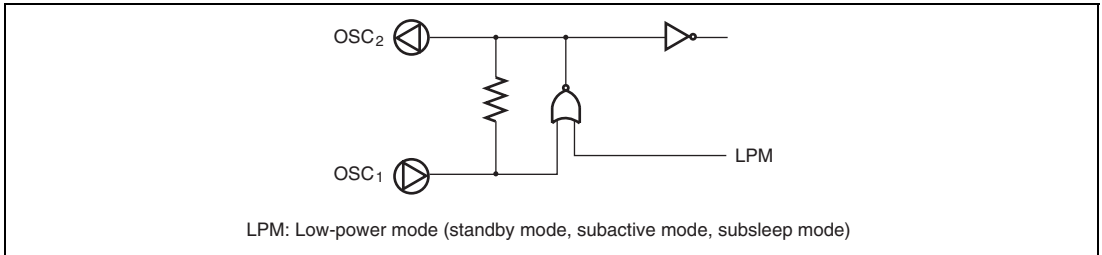

Figure 5.2 Block Diagram of System Clock Generator

5.1.1 Connecting Crystal Resonator

Figure 5.3 shows a typical method of connecting a crystal resonator. An AT-cut parallel-resonance crystal resonator should be used. Figure 5.4 shows the equivalent circuit of a crystal resonator. A resonator having the characteristics given in table 5.1 should be used.

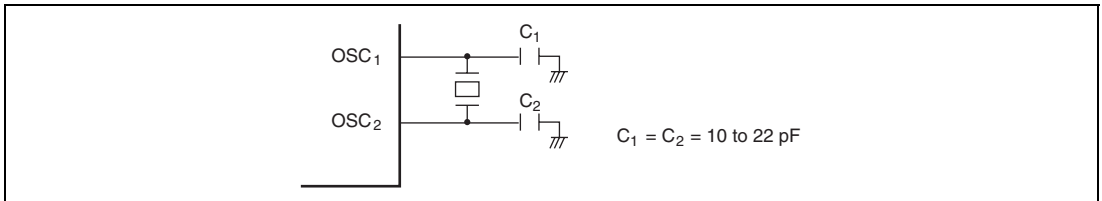

Figure 5.3 Typical Connection to Crystal Resonator

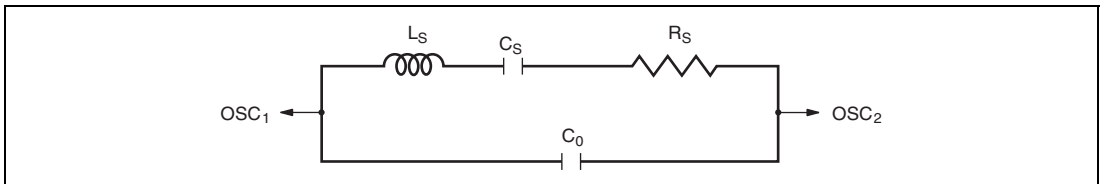

Figure 5.4 Equivalent Circuit of Crystal Resonator

Table 5.1 Crystal Resonator Parameters

| Frequency (MHz) | 2 | 4 | 8 | 10 | 16 | 20 |
|-----------------|--------------|--------------|-------------|-------------|-------------|-------------|
| R_s (max) | 500 Ω | 120 Ω | 80 Ω | 60 Ω | 50 Ω | 40 Ω |
| C_o (max) | 7 pF | 7 pF | 7 pF | 7 pF | 7 pF | 7 pF |

5.1.2 Connecting Ceramic Resonator

Figure 5.5 shows a typical method of connecting a ceramic resonator.

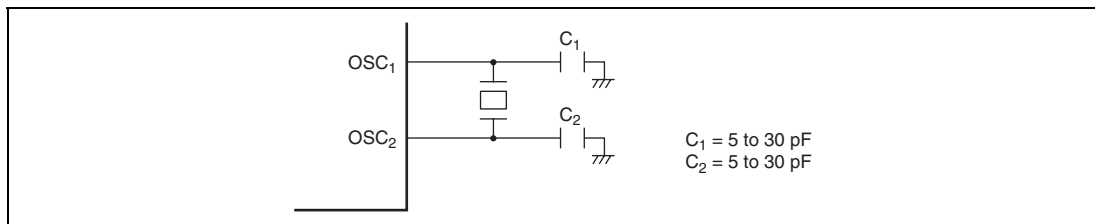
**Figure 5.5 Typical Connection to Ceramic Resonator**

5.1.3 External Clock Input Method

Connect an external clock signal to pin OSC₁, and leave pin OSC₂ open. Figure 5.6 shows a typical connection. The duty cycle of the external clock signal must be 45 to 55%.

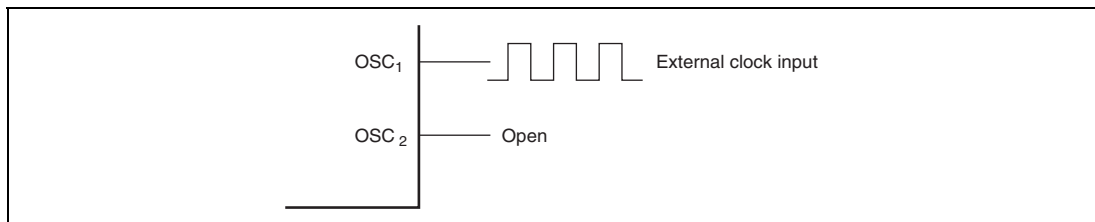
**Figure 5.6 Example of External Clock Input**

5.2 Subclock Generator

Figure 5.7 shows a block diagram of the subclock generator.

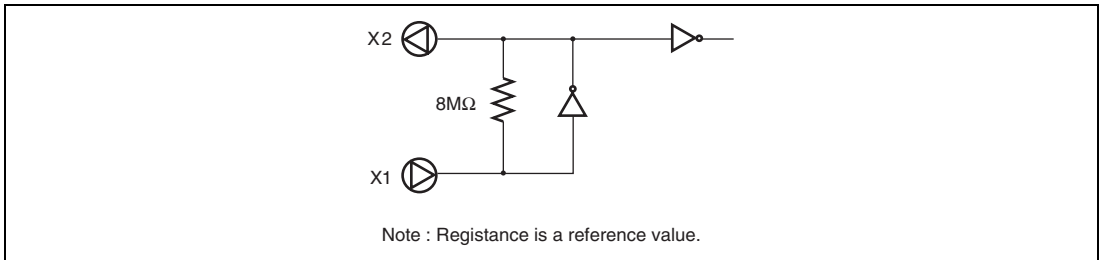

Figure 5.7 Block Diagram of Subclock Generator

5.2.1 Connecting 32.768-kHz Crystal Resonator

Clock pulses can be supplied to the subclock divider by connecting a 32.768-kHz crystal resonator, as shown in figure 5.8. Figure 5.9 shows the equivalent circuit of the 32.768-kHz crystal resonator.

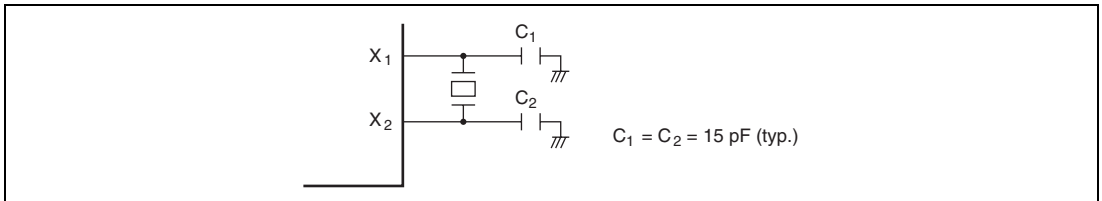

Figure 5.8 Typical Connection to 32.768-kHz Crystal Resonator

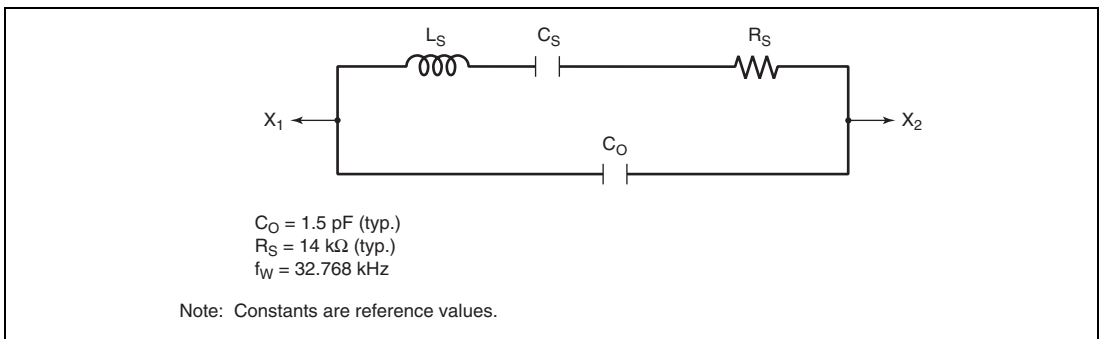

Figure 5.9 Equivalent Circuit of 32.768-kHz Crystal Resonator

5.2.2 Pin Connection when Not Using Subclock

When the subclock is not used, connect pin X_1 to V_{CL} or V_{SS} and leave pin X_2 open, as shown in figure 5.10.

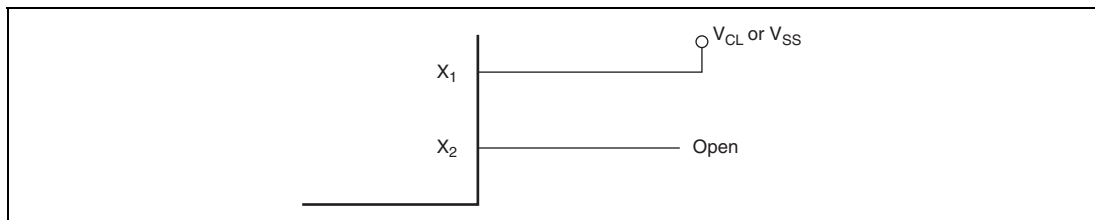

Figure 5.10 Pin Connection when not Using Subclock

5.3 Prescalers

5.3.1 Prescaler S

Prescaler S is a 13-bit counter using the system clock (ϕ) as its input clock. It is incremented once per clock period. Prescaler S is initialized to H'0000 by a reset, and starts counting on exit from the reset state. In standby mode, subactive mode, and subsleep mode, the system clock pulse generator stops. Prescaler S also stops and is initialized to H'0000. The CPU cannot read or write prescaler S. The output from prescaler S is shared by the on-chip peripheral modules. The divider ratio can be set separately for each on-chip peripheral function. In active mode and sleep mode, the clock input to prescaler S is determined by the division factor designated by MA2 to MA0 in SYSCR2.

5.3.2 Prescaler W

Prescaler W is a 5-bit counter using a 32.768 kHz signal divided by 4 ($\phi_w/4$) as its input clock. The divided output is used for clock time base operation of timer A. Prescaler W is initialized to H'00 by a reset, and starts counting on exit from the reset state. Even in standby mode, subactive mode, or subsleep mode, prescaler W continues functioning so long as clock signals are supplied to pins X_1 and X_2 . Prescaler W can be reset by setting 1s in bits TMA3 and TMA2 of timer mode register A (TMA).

5.4 Usage Notes

5.4.1 Note on Resonators

Resonator characteristics are closely related to board design and should be carefully evaluated by the user, referring to the examples shown in this section. Resonator circuit constants will differ depending on the resonator element, stray capacitance in its interconnecting circuit, and other factors. Suitable constants should be determined in consultation with the resonator element manufacturer. Design the circuit so that the resonator element never receives voltages exceeding its maximum rating.

5.4.2 Notes on Board Design

When using a crystal resonator (ceramic resonator), place the resonator and its load capacitors as close as possible to the OSC_1 and OSC_2 pins. Other signal lines should be routed away from the resonator circuit to prevent induction from interfering with correct oscillation (see figure 5.11).

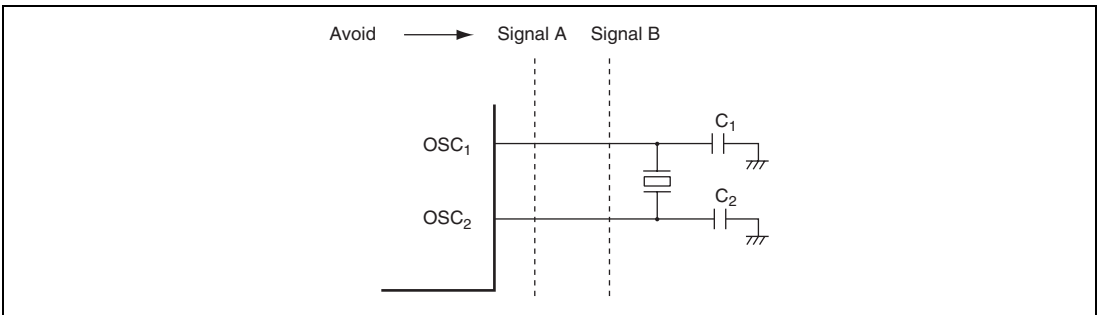

Figure 5.11 Example of Incorrect Board Design

Section 6 Power-Down Modes

This LSI has six modes of operation after a reset. These include a normal active mode and four power-down modes, in which power consumption is significantly reduced. Module standby mode reduces power consumption by selectively halting on-chip module functions.

- Active mode

The CPU and all on-chip peripheral modules are operable on the system clock. The system clock frequency can be selected from ϕ_{osc} , $\phi_{osc}/8$, $\phi_{osc}/16$, $\phi_{osc}/32$, and $\phi_{osc}/64$.

- Subactive mode

The CPU and all on-chip peripheral modules are operable on the subclock. The subclock frequency can be selected from $\phi_w/2$, $\phi_w/4$, and $\phi_w/8$.

- Sleep mode

The CPU halts. On-chip peripheral modules are operable on the system clock.

- Subsleep mode

The CPU halts. On-chip peripheral modules are operable on the subclock.

- Standby mode

The CPU and all on-chip peripheral modules halt. When the clock time-base function is selected, timer A is operable.

- Module standby mode

Independent of the above modes, power consumption can be reduced by halting on-chip peripheral modules that are not used in module units.

6.1 Register Descriptions

The registers related to power-down modes are listed below.

- System control register 1 (SYSCR1)
- System control register 2 (SYSCR2)
- Module standby control register 1 (MSTCR1)

6.1.1 System Control Register 1 (SYSCR1)

SYSCR1 controls the power-down modes, as well as SYSCR2.

| Bit | Bit Name | Initial Value | R/W | Description |
|--------|----------|---------------|-----|---|
| 7 | SSBY | 0 | R/W | <p>Software Standby</p> <p>This bit selects the mode to transit after the execution of the SLEEP instruction.</p> <p>0: a transition is made to sleep mode or subsleep mode.</p> <p>1: a transition is made to standby mode.</p> <p>For details, see table 6.2.</p> |
| 6 | STS2 | 0 | R/W | Standby Timer Select 2 to 0 |
| 5 | STS1 | 0 | R/W | <p>These bits designate the time the CPU and peripheral modules wait for stable clock operation after exiting from standby mode, subactive mode, or subsleep mode to active mode or sleep mode due to an interrupt. The designation should be made according to the clock frequency so that the waiting time is at least 6.5 ms. The relationship between the specified value and the number of wait states is shown in table 6.1. When an external clock is to be used, the minimum value (STS2 = STS1 = STS0 = 1) is recommended.</p> |
| 4 | STS0 | 0 | R/W | |
| 3 | NESEL | 0 | R/W | <p>Noise Elimination Sampling Frequency Select</p> <p>The subclock pulse generator generates the watch clock signal (ϕ_w) and the system clock pulse generator generates the oscillator clock (ϕ_{osc}). This bit selects the sampling frequency of the oscillator clock when the watch clock signal (ϕ_w) is sampled. When $\phi_{osc} = 4$ to 20 MHz, clear NESEL to 0.</p> <p>0: Sampling rate is $\phi_{osc}/16$</p> <p>1: Sampling rate is $\phi_{osc}/4$</p> |
| 2 to 0 | — | All 0 | — | <p>Reserved</p> <p>These bits are always read as 0.</p> |

Table 6.1 Operating Frequency and Waiting Time

| STS2 | STS1 | STS0 | Waiting Time | 20 MHz | 16 MHz | 10 MHz | 8 MHz | 4 MHz | 2 MHz | 1 MHz | 0.5 MHz |
|------|------|------|----------------|-----------|-----------|-----------|-------|-------|-------|-------|---------|
| 0 | 0 | 0 | 8,192 states | 0.4 | 0.5 | 0.8 | 1.0 | 2.0 | 4.1 | 8.1 | 16.4 |
| | | 1 | 16,384 states | 0.8 | 1.0 | 1.6 | 2.0 | 4.1 | 8.2 | 16.4 | 32.8 |
| | 1 | 0 | 32,768 states | 1.6 | 2.0 | 3.3 | 4.1 | 8.2 | 16.4 | 32.8 | 65.5 |
| | | 1 | 65,536 states | 3.3 | 4.1 | 6.6 | 8.2 | 16.4 | 32.8 | 65.5 | 131.1 |
| 1 | 0 | 0 | 131,072 states | 6.6 | 8.2 | 13.1 | 16.4 | 32.8 | 65.5 | 131.1 | 262.1 |
| | | 1 | 1,024 states | 0.05 | 0.06 | 0.10 | 0.13 | 0.26 | 0.51 | 1.02 | 2.05 |
| | 1 | 0 | 128 states | 0.00 | 0.00 | 0.01 | 0.02 | 0.03 | 0.06 | 0.13 | 0.26 |
| | | 1 | 16 states | 0.00 | 0.00 | 0.00 | 0.00 | 0.00 | 0.01 | 0.02 | 0.03 |

Note: Time unit is ms.

6.1.2 System Control Register 2 (SYSCR2)

SYSCR2 controls the power-down modes, as well as SYSCR1.

| Bit | Bit Name | Initial Value | R/W | Description | |
|---|----------|---------------|-----|--|--|
| 7 | SMSEL | 0 | R/W | Sleep Mode Selection | |
| 6 | LSON | 0 | R/W | Low Speed on Flag | |
| 5 | DTON | 0 | R/W | Direct Transfer on Flag | |
| <p>These bits select the mode to transit after the execution of a SLEEP instruction, as well as bit SSBY of SYSCR1. For details, see table 6.2.</p> | | | | | |
| 4 | MA2 | 0 | R/W | Active Mode Clock Select 2 to 0 | |
| 3 | MA1 | 0 | R/W | <p>These bits select the operating clock frequency in active and sleep modes. The operating clock frequency changes to the set frequency after the SLEEP instruction is executed.</p> <p>0XX: ϕ_{osc} 100: $\phi_{osc}/8$ 101: $\phi_{osc}/16$ 110: $\phi_{osc}/32$ 111: $\phi_{osc}/64$</p> | |
| 2 | MA0 | 0 | R/W | | |
| 1 | SA1 | 0 | R/W | | Subactive Mode Clock Select 1 and 0 |
| 0 | SA0 | 0 | R/W | | <p>These bits select the operating clock frequency in subactive and subsleep modes. The operating clock frequency changes to the set frequency after the SLEEP instruction is executed.</p> <p>00: $\phi_w/8$ 01: $\phi_w/4$ 1X: $\phi_w/2$</p> |
| | | | | | |

Legend: X : Don't care.

6.1.3 Module Standby Control Register 1 (MSTCR1)

MSTCR1 allows the on-chip peripheral modules to enter a standby state in module units.

| Bit | Bit Name | Initial Value | R/W | Description |
|-----|----------|---------------|-----|---|
| 7 | — | 0 | — | Reserved This bit is always read as 0. |
| 6 | MSTIIC | 0 | R/W | IIC Module Standby IIC enters standby mode when this bit is set to 1 |
| 5 | MSTS3 | 0 | R/W | SCI3 Module Standby SCI3 enters standby mode when this bit is set to 1 |
| 4 | MSTAD | 0 | R/W | A/D Converter Module Standby A/D converter enters standby mode when this bit is set to 1 |
| 3 | MSTWD | 0 | R/W | Watchdog Timer Module Standby Watchdog timer enters standby mode when this bit is set to 1. When the internal oscillator is selected for the watchdog timer clock, the watchdog timer operates regardless of the setting of this bit |
| 2 | MSTTW | 0 | R/W | Timer W Module Standby Timer W enters standby mode when this bit is set to 1 |
| 1 | MSTTV | 0 | R/W | Timer V Module Standby Timer V enters standby mode when this bit is set to 1 |
| 0 | MSTTA | 0 | R/W | Timer A Module Standby Timer A enters standby mode when this bit is set to 1 |

6.2 Mode Transitions and States of LSI

Figure 6.1 shows the possible transitions among these operating modes. A transition is made from the program execution state to the program halt state of the program by executing a SLEEP instruction. Interrupts allow for returning from the program halt state to the program execution state of the program. A direct transition between active mode and subactive mode, which are both program execution states, can be made without halting the program. The operating frequency can also be changed in the same modes by making a transition directly from active mode to active mode, and from subactive mode to subactive mode. $\overline{\text{RES}}$ input enables transitions from a mode to the reset state. Table 6.2 shows the transition conditions of each mode after the SLEEP instruction is executed and a mode to return by an interrupt. Table 6.3 shows the internal states of the LSI in each mode.

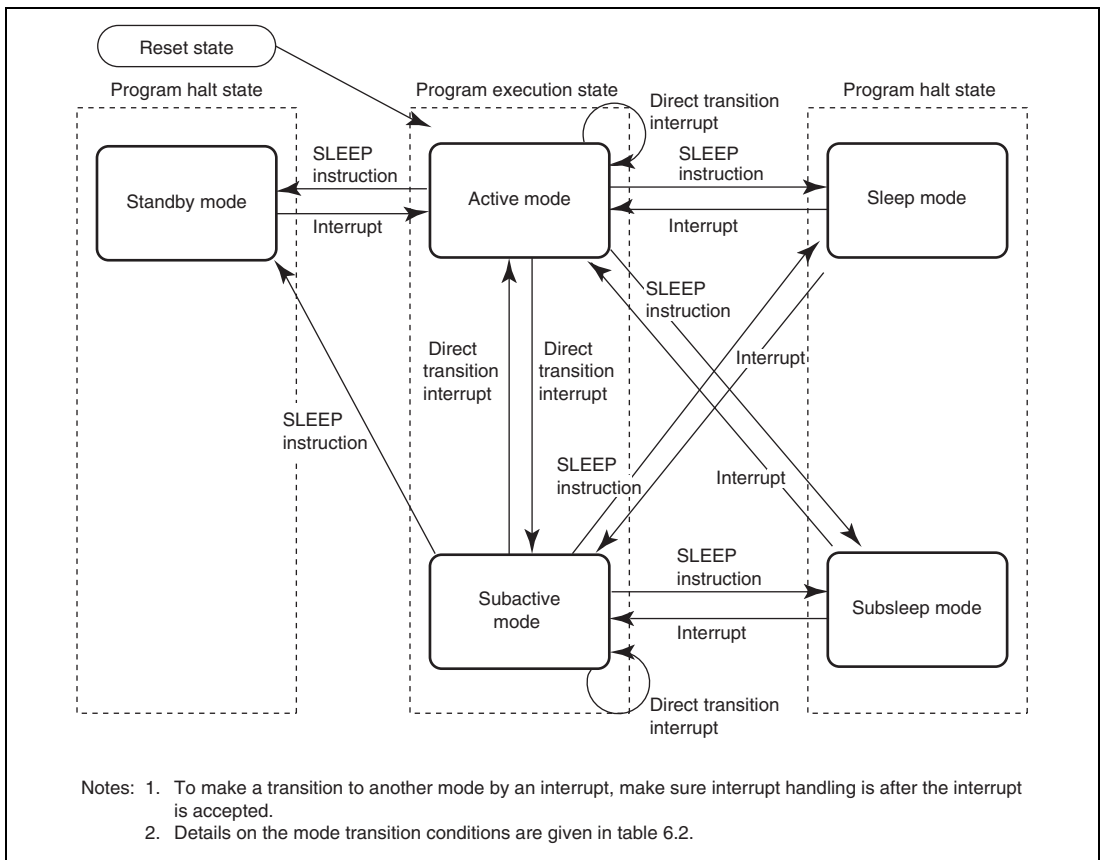

Figure 6.1 Mode Transition Diagram

Table 6.2 Transition Mode after SLEEP Instruction Execution and Interrupt Handling

| DTON | SSBY | SMSEL | LSON | Transition Mode after SLEEP Instruction Execution | Transition Mode due to Interrupt |
|-------------|-------------|--------------|-------------|--|---|
| 0 | 0 | 0 | 0 | Sleep mode | Active mode |
| | | | 1 | | Subactive mode |
| | 1 | X | 0 | Standby mode | Active mode |
| | | | 1 | | Subactive mode |
| 1 | X | 0* | 0 | Active mode (direct transition) | — |
| | X | X | 1 | Subactive mode (direct transition) | — |

Legend: X : Don't care.

- * When a state transition is performed while SMSEL is 1, timer V, SCI3, and the A/D converter are reset, and all registers are set to their initial values. To use these functions after entering active mode, reset the registers.

Table 6.3 Internal State in Each Operating Mode

| Function | | Active Mode | Sleep Mode | Subactive Mode | Subsleep Mode | Standby Mode |
|-------------------------|----------------|-------------|-------------|---|---------------|---|
| System clock oscillator | | Functioning | Functioning | Halted | Halted | Halted |
| Subclock oscillator | | Functioning | Functioning | Functioning | Functioning | Functioning |
| CPU operations | Instructions | Functioning | Halted | Functioning | Halted | Halted |
| | Registers | Functioning | Retained | Functioning | Retained | Retained |
| RAM | | Functioning | Retained | Functioning | Retained | Retained |
| IO ports | | Functioning | Retained | Functioning | Retained | Register contents are retained, but output is the high-impedance state. |
| External interrupts | IRQ3 to IRQ0 | Functioning | Functioning | Functioning | Functioning | Functioning |
| | WKP5 to WKP0 | Functioning | Functioning | Functioning | Functioning | Functioning |
| Peripheral functions | Timer A | Functioning | Functioning | Functioning if the timekeeping time-base function is selected, and retained if not selected | | |
| | Timer V | Functioning | Functioning | Reset | Reset | Reset |
| | Timer W | Functioning | Functioning | Retained (if internal clock ϕ is selected as a count clock, the counter is incremented by a subclock*) | | Retained |
| | Watchdog timer | Functioning | Functioning | Retained (functioning if the internal oscillator is selected as a count clock*) | | |
| | SCI3 | Functioning | Functioning | Reset | Reset | Reset |
| | IIC | Functioning | Functioning | Retained* | Retained | Retained |
| | A/D converter | Functioning | Functioning | Reset | Reset | Reset |

Note: * Registers can be read or written in subactive mode.

6.2.1 Sleep Mode

In sleep mode, CPU operation is halted but the on-chip peripheral modules function at the clock frequency set by the MA2, MA1, and MA0 bits in SYSCR2. CPU register contents are retained. When an interrupt is requested, sleep mode is cleared and interrupt exception handling starts. Sleep mode is not cleared if the I bit of the condition code register (CCR) is set to 1 or the requested interrupt is disabled in the interrupt enable register. After sleep mode is cleared, a transition is made to active mode when the LSON bit in SYSCR2 is 0, and a transition is made to subactive mode when the bit is 1.

When the $\overline{\text{RES}}$ pin goes low, the CPU goes into the reset state and sleep mode is cleared.

6.2.2 Standby Mode

In standby mode, the clock pulse generator stops, so the CPU and on-chip peripheral modules stop functioning. However, as long as the rated voltage is supplied, the contents of CPU registers, on-chip RAM, and some on-chip peripheral module registers are retained. On-chip RAM contents will be retained as long as the voltage set by the RAM data retention voltage is provided. The I/O ports go to the high-impedance state.

Standby mode is cleared by an interrupt. When an interrupt is requested, the system clock pulse generator starts. After the time set in bits STS2–STS0 in SYSCR1 has elapsed, and interrupt exception handling starts. Standby mode is not cleared if the I bit of CCR is set to 1 or the requested interrupt is disabled in the interrupt enable register.

When the $\overline{\text{RES}}$ pin goes low, the system clock pulse generator starts. Since system clock signals are supplied to the entire chip as soon as the system clock pulse generator starts functioning, the $\overline{\text{RES}}$ pin must be kept low until the pulse generator output stabilizes. After the pulse generator output has stabilized, the CPU starts reset exception handling if the $\overline{\text{RES}}$ pin is driven high.

6.2.3 Subsleep Mode

In subsleep mode, operation of the CPU and on-chip peripheral modules other than timer A is halted. As long as a required voltage is applied, the contents of CPU registers, the on-chip RAM, and some registers of the on-chip peripheral modules are retained. I/O ports keep the same states as before the transition.

Subsleep mode is cleared by an interrupt. When an interrupt is requested, subsleep mode is cleared and interrupt exception handling starts. Subsleep mode is not cleared if the I bit of CCR is set to 1 or the requested interrupt is disabled in the interrupt enable register. After subsleep mode is

cleared, a transition is made to active mode when the LSON bit in SYSCR2 is 0, and a transition is made to subactive mode when the bit is 1.

When the $\overline{\text{RES}}$ pin goes low, the system clock pulse generator starts. Since system clock signals are supplied to the entire chip as soon as the system clock pulse generator starts functioning, the $\overline{\text{RES}}$ pin must be kept low until the pulse generator output stabilizes. After the pulse generator output has stabilized, the CPU starts reset exception handling if the $\overline{\text{RES}}$ pin is driven high.

6.2.4 Subactive Mode

The operating frequency of subactive mode is selected from $\phi_w/2$, $\phi_w/4$, and $\phi_w/8$ by the SA1 and SA0 bits in SYSCR2. After the SLEEP instruction is executed, the operating frequency changes to the frequency which is set before the execution. When the SLEEP instruction is executed in subactive mode, a transition to sleep mode, subsleep mode, standby mode, active mode, or subactive mode is made, depending on the combination of SYSCR1 and SYSCR2. When the $\overline{\text{RES}}$ pin goes low, the system clock pulse generator starts. Since system clock signals are supplied to the entire chip as soon as the system clock pulse generator starts functioning, the $\overline{\text{RES}}$ pin must be kept low until the pulse generator output stabilizes. After the pulse generator output has stabilized, the CPU starts reset exception handling if the $\overline{\text{RES}}$ pin is driven high.

6.3 Operating Frequency in Active Mode

Operation in active mode is clocked at the frequency designated by the MA2, MA1, and MA0 bits in SYSCR2. The operating frequency changes to the set frequency after SLEEP instruction execution.

6.4 Direct Transition

The CPU can execute programs in two modes: active and subactive mode. A direct transition is a transition between these two modes without stopping program execution. A direct transition can be made by executing a SLEEP instruction while the DTON bit in SYSCR2 is set to 1. The direct transition also enables operating frequency modification in active or subactive mode. After the mode transition, direct transition interrupt exception handling starts.

If the direct transition interrupt is disabled in interrupt enable register 1, a transition is made instead to sleep or subsleep mode. Note that if a direct transition is attempted while the I bit in CCR is set to 1, sleep or subsleep mode will be entered, and the resulting mode cannot be cleared by means of an interrupt.

6.4.1 Direct Transition from Active Mode to Subactive Mode

The time from the start of SLEEP instruction execution to the end of interrupt exception handling (the direct transition time) is calculated by equation (1).

Direct transition time = {(number of SLEEP instruction execution states) + (number of internal processing states)} × (tcyc before transition) + (number of interrupt exception handling states) × (tsubcyc after transition) (1)

Example

Direct transition time = $(2 + 1) \times \text{tosc} + 14 \times 8\text{tw} = 3\text{tosc} + 112\text{tw}$
(when the CPU operating clock of $\phi_{\text{osc}} \rightarrow \phi_{\text{w}}/8$ is selected)

Legend

tosc: OSC clock cycle time

tw: watch clock cycle time

tcyc: system clock (ϕ) cycle time

tsubcyc: subclock (ϕ_{SUB}) cycle time

6.4.2 Direct Transition from Subactive Mode to Active Mode

The time from the start of SLEEP instruction execution to the end of interrupt exception handling (the direct transition time) is calculated by equation (2).

Direct transition time = {(number of SLEEP instruction execution states) + (number of internal processing states)} × (tsubcyc before transition) + {(waiting time set in bits STS2 to STS0) + (number of interrupt exception handling states)} × (tcyc after transition) (2)

Example

Direct transition time = $(2 + 1) \times 8tw + (8192 + 14) \times tosc = 24tw + 8206tosc$

(when the CPU operating clock of $\phi_w/8 \rightarrow \phi_{osc}$ and a waiting time of 8192 states are selected)

Legend

tosc: OSC clock cycle time

tw: watch clock cycle time

tcyc: system clock (ϕ) cycle time

tsubcyc: subclock (ϕ_{SUB}) cycle time

6.5 Module Standby Function

The module-standby function can be set to any peripheral module. In module standby mode, the clock supply to modules stops to enter the power-down mode. Module standby mode enables each on-chip peripheral module to enter the standby state by setting a bit that corresponds to each module to 1 and cancels the mode by clearing the bit to 0.

Section 7 ROM

The features of the 32-kbyte flash memory built into the flash memory version are summarized below.

- Programming/erase methods
 - The flash memory is programmed 128 bytes at a time. Erase is performed in single-block units. The flash memory is configured as follows: 1 kbyte \times 4 blocks and 28 kbytes \times 1 block. To erase the entire flash memory, each block must be erased in turn.
- Reprogramming capability
 - The flash memory can be reprogrammed up to 1,000 times.
- On-board programming
 - On-board programming/erasing can be done in boot mode, in which the boot program built into the chip is started to erase or program of the entire flash memory. In normal user program mode, individual blocks can be erased or programmed.
- Programmer mode
 - Flash memory can be programmed/erased in programmer mode using a PROM programmer, as well as in on-board programming mode.
- Automatic bit rate adjustment
 - For data transfer in boot mode, this LSI's bit rate can be automatically adjusted to match the transfer bit rate of the host.
- Programming/erasing protection
 - Sets software protection against flash memory programming/erasing.
- Power-down mode
 - Operation of the power supply circuit can be partly halted in subactive mode. As a result, flash memory can be read with low power consumption.

7.1 Block Configuration

Figure 7.1 shows the block configuration of 32-kbyte flash memory. The thick lines indicate erasing units, the narrow lines indicate programming units, and the values are addresses. The flash memory is divided into 1 kbyte \times 4 blocks and 28 kbytes \times 1 block. Erasing is performed in these units. Programming is performed in 128-byte units starting from an address with lower eight bits H'00 or H'80.

| | | | | | |
|-------------------------|--------|--------|--------|---------------------------------|--------|
| Erase unit 1kbyte | H'0000 | H'0001 | H'0002 | ← Programming unit: 128 bytes → | H'007F |
| | H'0080 | H'0081 | H'0082 | | H'00FF |
| Erase unit 1kbyte | H'0380 | H'0381 | H'0382 | | H'03FF |
| | H'0400 | H'0401 | H'0402 | ← Programming unit: 128 bytes → | H'047F |
| Erase unit 1kbyte | H'0480 | H'0481 | H'0481 | | H'04FF |
| | H'0780 | H'0781 | H'0782 | | H'07FF |
| Erase unit 1kbyte | H'0800 | H'0801 | H'0802 | ← Programming unit: 128 bytes → | H'087F |
| | H'0880 | H'0881 | H'0882 | | H'08FF |
| Erase unit 1kbyte | H'0B80 | H'0B81 | H'0B82 | | H'0BFF |
| | H'0C00 | H'0C01 | H'0C02 | ← Programming unit: 128 bytes → | H'0C7F |
| Erase unit 1kbyte | H'0C80 | H'0C81 | H'0C82 | | H'0CFF |
| | H'0F80 | H'0F81 | H'0F82 | | H'0FFF |
| Erase unit 28 kbytes | H'1000 | H'1001 | H'1002 | ← Programming unit: 128 bytes → | H'107F |
| | H'1080 | H'1081 | H'1082 | | H'10FF |
| | H'7F80 | H'7F81 | H'7F82 | | H'7FFF |

Figure 7.1 Flash Memory Block Configuration

7.2 Register Descriptions

The flash memory has the following registers.

- Flash memory control register 1 (FLMCR1)
- Flash memory control register 2 (FLMCR2)
- Erase block register 1 (EBR1)
- Flash memory power control register (FLPWCR)
- Flash memory enable register (FENR)

7.2.1 Flash Memory Control Register 1 (FLMCR1)

FLMCR1 is a register that makes the flash memory change to program mode, program-verify mode, erase mode, or erase-verify mode. For details on register setting, refer to section 7.4, Flash Memory Programming/Erasing.

| Bit | Bit Name | Initial Value | R/W | Description |
|-----|----------|---------------|-----|---|
| 7 | — | 0 | — | Reserved This bit is always read as 0. |
| 6 | SWE | 0 | R/W | Software Write Enable When this bit is set to 1, flash memory programming/erasing is enabled. When this bit is cleared to 0, other FLMCR1 register bits and all EBR1 bits cannot be set. |
| 5 | ESU | 0 | R/W | Erase Setup When this bit is set to 1, the flash memory changes to the erase setup state. When it is cleared to 0, the erase setup state is cancelled. Set this bit to 1 before setting the E bit to 1 in FLMCR1. |
| 4 | PSU | 0 | R/W | Program Setup When this bit is set to 1, the flash memory changes to the program setup state. When it is cleared to 0, the program setup state is cancelled. Set this bit to 1 before setting the P bit in FLMCR1. |
| 3 | EV | 0 | R/W | Erase-Verify When this bit is set to 1, the flash memory changes to erase-verify mode. When it is cleared to 0, erase-verify mode is cancelled. |
| 2 | PV | 0 | R/W | Program-Verify When this bit is set to 1, the flash memory changes to program-verify mode. When it is cleared to 0, program-verify mode is cancelled. |
| 1 | E | 0 | R/W | Erase When this bit is set to 1, and while the SWE=1 and ESU=1 bits are 1, the flash memory changes to erase mode. When it is cleared to 0, erase mode is cancelled. |

| Bit | Bit Name | Initial Value | R/W | Description |
|-----|----------|---------------|-----|---|
| 0 | P | 0 | R/W | Program When this bit is set to 1, and while the SWE=1 and PSU=1 bits are 1, the flash memory changes to program mode. When it is cleared to 0, program mode is cancelled. |

7.2.2 Flash Memory Control Register 2 (FLMCR2)

FLMCR2 is a register that displays the state of flash memory programming/erasing. FLMCR2 is a read-only register, and should not be written to.

| Bit | Bit Name | Initial Value | R/W | Description |
|--------|----------|---------------|-----|---|
| 7 | FLER | 0 | R | Flash Memory Error Indicates that an error has occurred during an operation on flash memory (programming or erasing). When FLER is set to 1, flash memory goes to the error-protection state. See 7.5.3, Error Protection, for details. |
| 6 to 0 | — | All 0 | — | Reserved These bits are always read as 0. |

7.2.3 Erase Block Register 1 (EBR1)

EBR1 specifies the flash memory erase area block. EBR1 is initialized to H'00 when the SWE bit in FLMCR1 is 0. Do not set more than one bit at a time, as this will cause all the bits in EBR1 to be automatically cleared to 0.

| Bit | Bit Name | Initial Value | R/W | Description |
|--------|----------|---------------|-----|--|
| 7 to 5 | — | All 0 | — | Reserved These bits are always read as 0. |
| 4 | EB4 | 0 | R/W | When this bit is set to 1, 28 kbytes of H'1000 to H'7FFF will be erased. |
| 3 | EB3 | 0 | R/W | When this bit is set to 1, 1 kbyte of H'0C00 to H'0FFF will be erased. |
| 2 | EB2 | 0 | R/W | When this bit is set to 1, 1 kbyte of H'0800 to H'0BFF will be erased. |
| 1 | EB1 | 0 | R/W | When this bit is set to 1, 1 kbyte of H'0400 to H'07FF will be erased. |
| 0 | EB0 | 0 | R/W | When this bit is set to 1, 1 kbyte of H'0000 to H'03FF will be erased. |

7.2.4 Flash Memory Power Control Register (FLPWCR)

FLPWCR enables or disables a transition to the flash memory power-down mode when the LSI switches to subactive mode. There are two modes: mode in which operation of the power supply circuit of flash memory is partly halted in power-down mode and flash memory can be read, and mode in which even if a transition is made to subactive mode, operation of the power supply circuit of flash memory is retained and flash memory can be read.

| Bit | Bit Name | Initial Value | R/W | Description |
|--------|----------|---------------|-----|--|
| 7 | PDWND | 0 | R/W | Power-Down Disable When this bit is 0 and a transition is made to subactive mode, the flash memory enters the power-down mode. When this bit is 1, the flash memory remains in the normal mode even after a transition is made to subactive mode. |
| 6 to 0 | — | All 0 | — | Reserved These bits are always read as 0. |

7.2.5 Flash Memory Enable Register (FENR)

Bit 7 (FLSHE) in FENR enables or disables the CPU access to the flash memory control registers, FLMCR1, FLMCR2, EBR1, and FLPWCR.

| Bit | Bit Name | Initial Value | R/W | Description |
|--------|----------|---------------|-----|--|
| 7 | FLSHE | 0 | R/W | Flash Memory Control Register Enable Flash memory control registers can be accessed when this bit is set to 1. Flash memory control registers cannot be accessed when this bit is set to 0. |
| 6 to 0 | — | All 0 | — | Reserved These bits are always read as 0. |

7.3 On-Board Programming Modes

There are two modes for programming/erasing of the flash memory; boot mode, which enables on-board programming/erasing, and programmer mode, in which programming/erasing is performed with a PROM programmer. On-board programming/erasing can also be performed in user program mode. At reset-start in reset mode, this LSI changes to a mode depending on the TEST pin settings, NMI pin settings, and input level of each port, as shown in table 7.1. The input level of each pin must be defined four states before the reset ends.

When changing to boot mode, the boot program built into this LSI is initiated. The boot program transfers the programming control program from the externally-connected host to on-chip RAM via SCI3. After erasing the entire flash memory, the programming control program is executed. This can be used for programming initial values in the on-board state or for a forcible return when programming/erasing can no longer be done in user program mode. In user program mode, individual blocks can be erased and programmed by branching to the user program/erase control program prepared by the user.

Table 7.1 Setting Programming Modes

| TEST | $\overline{\text{NMI}}$ | P85 | PB0 | PB1 | PB2 | LSI State after Reset End |
|------|-------------------------|-----|-----|-----|-----|---------------------------|
| 0 | 1 | X | X | X | X | User Mode |
| 0 | 0 | 1 | X | X | X | Boot Mode |
| 1 | X | X | 0 | 0 | 0 | Programmer Mode |

Legend: X : Don't care.

7.3.1 Boot Mode

Table 7.2 shows the boot mode operations between reset end and branching to the programming control program.

1. When boot mode is used, the flash memory programming control program must be prepared in the host beforehand. Prepare a programming control program in accordance with the description in section 7.4, Flash Memory Programming/Erasing.
2. SCI3 should be set to asynchronous mode, and the transfer format as follows: 8-bit data, 1 stop bit, and no parity.
3. When the boot program is initiated, the chip measures the low-level period of asynchronous SCI communication data (H'00) transmitted continuously from the host. The chip then calculates the bit rate of transmission from the host, and adjusts the SCI3 bit rate to match that of the host. The reset should end with the RxD pin high. The RxD and TxD pins should be

pulled up on the board if necessary. After the reset is complete, it takes approximately 100 states before the chip is ready to measure the low-level period.

4. After matching the bit rates, the chip transmits one H'00 byte to the host to indicate the completion of bit rate adjustment. The host should confirm that this adjustment end indication (H'00) has been received normally, and transmit one H'55 byte to the chip. If reception could not be performed normally, initiate boot mode again by a reset. Depending on the host's transfer bit rate and system clock frequency of this LSI, there will be a discrepancy between the bit rates of the host and the chip. To operate the SCI properly, set the host's transfer bit rate and system clock frequency of this LSI within the ranges listed in table 7.3.
5. In boot mode, a part of the on-chip RAM area is used by the boot program. The area H'F780 to H'FEFF is the area to which the programming control program is transferred from the host. The boot program area cannot be used until the execution state in boot mode switches to the programming control program.
6. Before branching to the programming control program, the chip terminates transfer operations by SCI3 (by clearing the RE and TE bits in SCR to 0), however the adjusted bit rate value remains set in BRR. Therefore, the programming control program can still use it for transfer of write data or verify data with the host. The TxD pin is high (PCR22 = 1, P22 = 1). The contents of the CPU general registers are undefined immediately after branching to the programming control program. These registers must be initialized at the beginning of the programming control program, as the stack pointer (SP), in particular, is used implicitly in subroutine calls, etc.
7. Boot mode can be cleared by a reset. End the reset after driving the reset pin low, waiting at least 20 states, and then setting the $\overline{\text{NMI}}$ pin. Boot mode is also cleared when a WDT overflow occurs.
8. Do not change the TEST pin and NMI pin input levels in boot mode.

Table 7.2 Boot Mode Operation

| Item | Host Operation | Communication Contents | LSI Operation |
|--|--|--|---|
| | Processing Contents | | Processing Contents |
| Boot mode initiation | | | Branches to boot program at reset-start.  |
| Bit rate adjustment | Continuously transmits data H'00 at specified bit rate. ↓ Transmits data H'55 when data H'00 is received error-free. | H'00, H'00 ... H'00 ← H'00 ← H'55 | <ul style="list-style-type: none"> Measures low-level period of receive data H'00. Calculates bit rate and sets BRR in SCI3. Transmits data H'00 to host as adjustment end indication. H'55 reception. |
| Flash memory erase | ↓ Boot program erase error ← H'AA reception ← | ← H'FF ← H'AA | Checks flash memory data, erases all flash memory blocks in case of written data existing, and transmits data H'AA to host. (If erase could not be done, transmits data H'FF to host and aborts operation.) |
| Transfer of number of bytes of programming control program | Transmits number of bytes (N) of programming control program to be transferred as 2-byte data (low-order byte following high-order byte) ↓ Transmits 1-byte of programming control program (repeated for N times) ↓ H'AA reception ← | ← Upper bytes, lower bytes ← Echoback ← H'XX ← Echoback ← H'AA | Echobacks the 2-byte data received to host. ↓ Echobacks received data to host and also transfers it to RAM. (repeated for N times) ↓ Transmits data H'AA to host. |
| | | | Branches to programming control program transferred to on-chip RAM and starts execution. |

Table 7.3 System Clock Frequencies for which Automatic Adjustment of LSI Bit Rate is Possible

| Host Bit Rate | System Clock Frequency Range of LSI |
|----------------------|--|
| 19,200 bps | 16 to 20 MHz |
| 9,600 bps | 8 to 16 MHz |
| 4,800 bps | 4 to 16 MHz |
| 2,400 bps | 2 to 16 MHz |

7.3.2 Programming/Erasing in User Program Mode

On-board programming/erasing of an individual flash memory block can also be performed in user program mode by branching to a user program/erase control program. The user must set branching conditions and provide on-board means of supplying programming data. The flash memory must contain the user program/erase control program or a program that provides the user program/erase control program from external memory. As the flash memory itself cannot be read during programming/erasing, transfer the user program/erase control program to on-chip RAM, as in boot mode. Figure 7.2 shows a sample procedure for programming/erasing in user program mode.

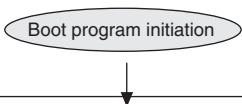
Prepare a user program/erase control program in accordance with the description in section 7.4, Flash Memory Programming/Erasing.

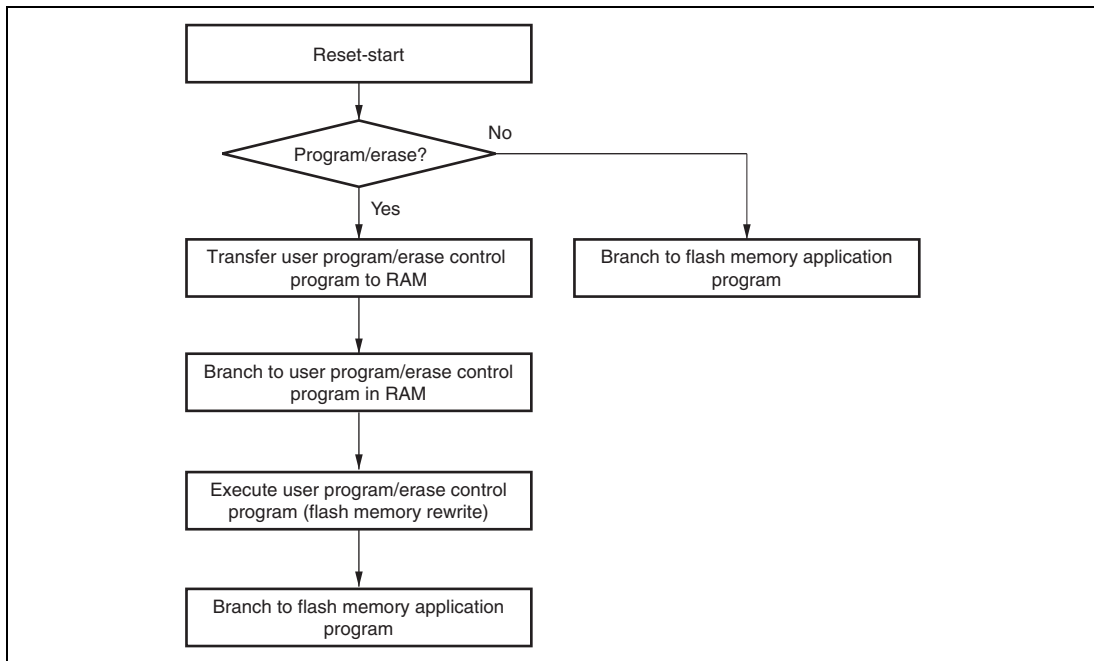

Figure 7.2 Programming/Erasing Flowchart Example in User Program Mode

7.4 Flash Memory Programming/Erasing

A software method using the CPU is employed to program and erase flash memory in the on-board programming modes. Depending on the FLMCR1 setting, the flash memory operates in one of the following four modes: Program mode, program-verify mode, erase mode, and erase-verify mode. The programming control program in boot mode and the user program/erase control program in user program mode use these operating modes in combination to perform programming/erasing. Flash memory programming and erasing should be performed in accordance with the descriptions in section 7.4.1, Program/Program-Verify and section 7.4.2, Erase/Erase-Verify, respectively.

7.4.1 Program/Program-Verify

When writing data or programs to the flash memory, the program/program-verify flowchart shown in figure 7.3 should be followed. Performing programming operations according to this flowchart will enable data or programs to be written to the flash memory without subjecting the chip to voltage stress or sacrificing program data reliability.

1. Programming must be done to an empty address. Do not reprogram an address to which programming has already been performed.
2. Programming should be carried out 128 bytes at a time. A 128-byte data transfer must be performed even if writing fewer than 128 bytes. In this case, H'FF data must be written to the extra addresses.
3. Prepare the following data storage areas in RAM: A 128-byte programming data area, a 128-byte reprogramming data area, and a 128-byte additional-programming data area. Perform reprogramming data computation according to table 7.4, and additional programming data computation according to table 7.5.
4. Consecutively transfer 128 bytes of data in byte units from the reprogramming data area or additional-programming data area to the flash memory. The program address and 128-byte data are latched in the flash memory. The lower 8 bits of the start address in the flash memory destination area must be H'00 or H'80.
5. The time during which the P bit is set to 1 is the programming time. Table 7.6 shows the allowable programming times.
6. The watchdog timer (WDT) is set to prevent overprogramming due to program runaway, etc. An overflow cycle of approximately 6.6 ms is allowed.
7. For a dummy write to a verify address, write 1-byte data H'FF to an address whose lower 2 bits are B'00. Verify data can be read in words or in longwords from the address to which a dummy write was performed.

8. The maximum number of repetitions of the program/program-verify sequence of the same bit is 1,000.

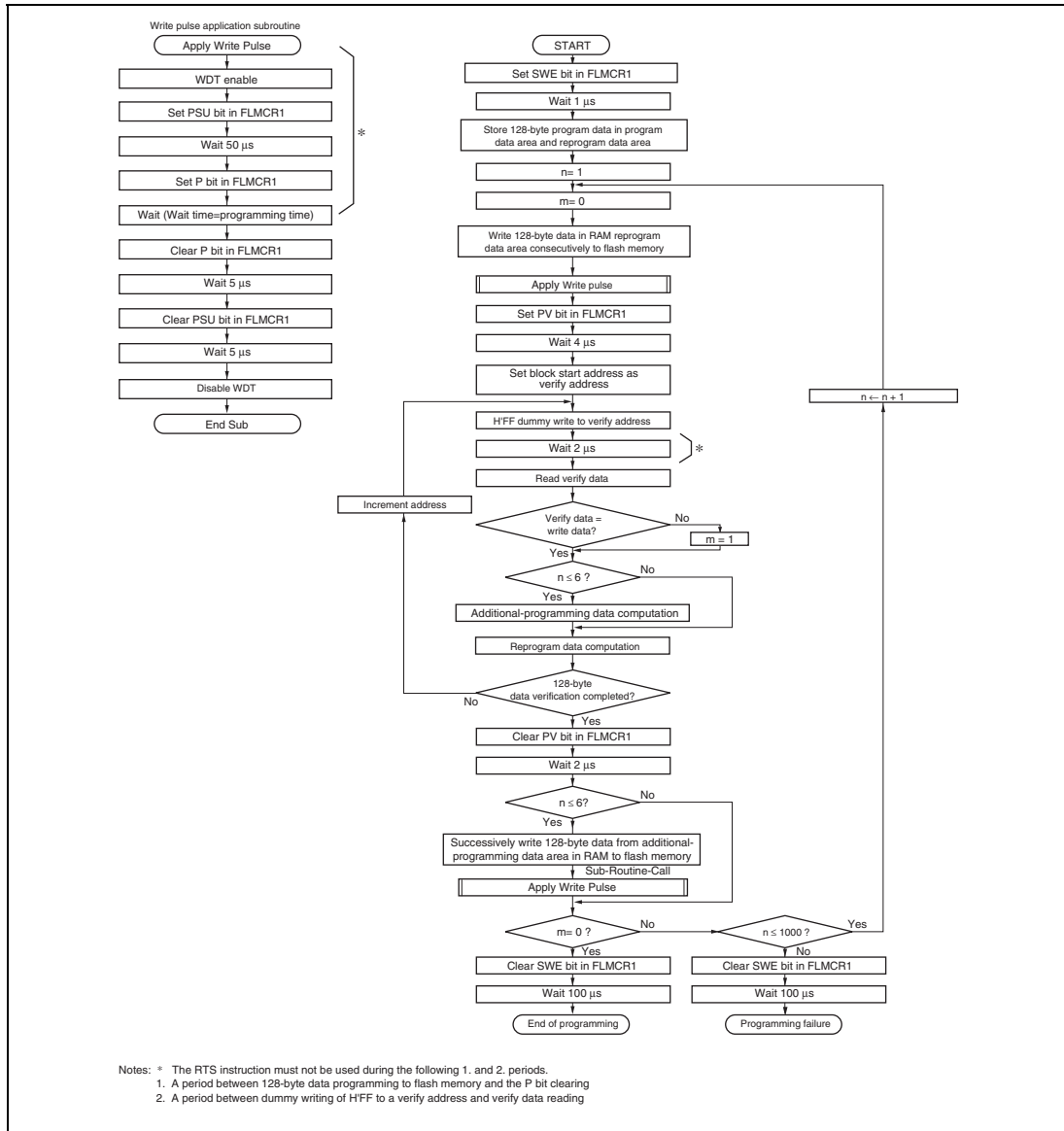

Notes: * The RTS instruction must not be used during the following 1. and 2. periods.
 1. A period between 128-byte data programming to flash memory and the P bit clearing
 2. A period between dummy writing of HFF to a verify address and verify data reading

Figure 7.3 Program/Program-Verify Flowchart

Table 7.4 Reprogram Data Computation Table

| Program Data | Verify Data | Reprogram Data | Comments |
|--------------|-------------|----------------|-------------------------|
| 0 | 0 | 1 | Programming completed |
| 0 | 1 | 0 | Reprogram bit |
| 1 | 0 | 1 | — |
| 1 | 1 | 1 | Remains in erased state |

Table 7.5 Additional-Program Data Computation Table

| Reprogram Data | Verify Data | Additional-Program Data | Comments |
|----------------|-------------|-------------------------|---------------------------|
| 0 | 0 | 0 | Additional-program bit |
| 0 | 1 | 1 | No additional programming |
| 1 | 0 | 1 | No additional programming |
| 1 | 1 | 1 | No additional programming |

Table 7.6 Programming Time

| n (Number of Writes) | Programming Time | In Additional Programming | Comments |
|-------------------------|------------------|---------------------------|----------|
| 1 to 6 | 30 | 10 | |
| 7 to 1,000 | 200 | — | |

Note: Time shown in μ s.

7.4.2 Erase/Erase-Verify

When erasing flash memory, the erase/erase-verify flowchart shown in figure 7.4 should be followed.

1. Prewriting (setting erase block data to all 0s) is not necessary.
2. Erasing is performed in block units. Make only a single-bit specification in the erase block register (EBR1). To erase multiple blocks, each block must be erased in turn.
3. The time during which the E bit is set to 1 is the flash memory erase time.
4. The watchdog timer (WDT) is set to prevent overerasing due to program runaway, etc. An overflow cycle of approximately 19.8 ms is allowed.

5. For a dummy write to a verify address, write 1-byte data H'FF to an address whose lower two bits are B'00. Verify data can be read in longwords from the address to which a dummy write was performed.
6. If the read data is not erased successfully, set erase mode again, and repeat the erase/erase-verify sequence as before. The maximum number of repetitions of the erase/erase-verify sequence is 100.

7.4.3 Interrupt Handling when Programming/Erasing Flash Memory

All interrupts, including the NMI interrupt, are disabled while flash memory is being programmed or erased, or while the boot program is executing, for the following three reasons:

1. Interrupt during programming/erasing may cause a violation of the programming or erasing algorithm, with the result that normal operation cannot be assured.
2. If interrupt exception handling starts before the vector address is written or during programming/erasing, a correct vector cannot be fetched and the CPU malfunctions.
3. If an interrupt occurs during boot program execution, normal boot mode sequence cannot be carried out.

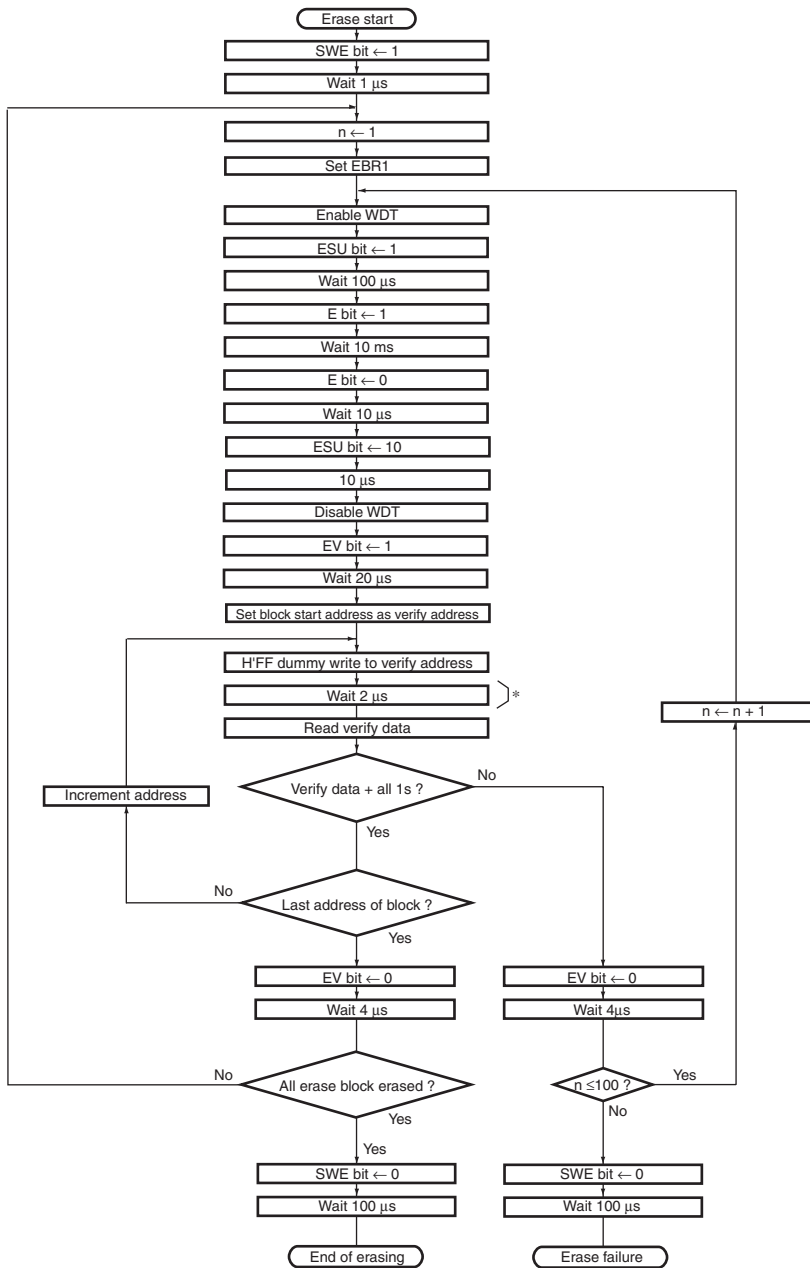

Note: *The RTS instruction must not be used during a period between dummy writing of HFF to a verify address and verify data reading.

Figure 7.4 Erase/Eraser-Verify Flowchart

7.5 Program/Erase Protection

There are three kinds of flash memory program/erase protection; hardware protection, software protection, and error protection.

7.5.1 Hardware Protection

Hardware protection refers to a state in which programming/erasing of flash memory is forcibly disabled or aborted because of a transition to reset, subactive mode, subsleep mode, or standby mode. Flash memory control register 1 (FLMCR1), flash memory control register 2 (FLMCR2), and erase block register 1 (EBR1) are initialized. In a reset via the $\overline{\text{RES}}$ pin, the reset state is not entered unless the $\overline{\text{RES}}$ pin is held low until oscillation stabilizes after powering on. In the case of a reset during operation, hold the $\overline{\text{RES}}$ pin low for the $\overline{\text{RES}}$ pulse width specified in the AC Characteristics section.

7.5.2 Software Protection

Software protection can be implemented against programming/erasing of all flash memory blocks by clearing the SWE bit in FLMCR1. When software protection is in effect, setting the P or E bit in FLMCR1 does not cause a transition to program mode or erase mode. By setting the erase block register 1 (EBR1), erase protection can be set for individual blocks. When EBR1 is set to H'00, erase protection is set for all blocks.

7.5.3 Error Protection

In error protection, an error is detected when CPU runaway occurs during flash memory programming/erasing, or operation is not performed in accordance with the program/erase algorithm, and the program/erase operation is aborted. Aborting the program/erase operation prevents damage to the flash memory due to overprogramming or overerasing.

When the following errors are detected during programming/erasing of flash memory, the FLER bit in FLMCR2 is set to 1, and the error protection state is entered.

- When the flash memory of the relevant address area is read during programming/erasing (including vector read and instruction fetch)
- Immediately after exception handling excluding a reset during programming/erasing
- When a SLEEP instruction is executed during programming/erasing

The FLMCR1, FLMCR2, and EBR1 settings are retained, however program mode or erase mode is aborted at the point at which the error occurred. Program mode or erase mode cannot be re-

entered by re-setting the P or E bit. However, PV and EV bit setting is enabled, and a transition can be made to verify mode. Error protection can be cleared only by a reset.

7.6 Programmer Mode

In programmer mode, a PROM programmer can be used to perform programming/erasing via a socket adapter, just as a discrete flash memory. Use a PROM programmer that supports the MCU device type with the on-chip 64-kbyte flash memory (FZTAT64V5).

7.7 Power-Down States for Flash Memory

In user mode, the flash memory will operate in either of the following states:

- Normal operating mode
The flash memory can be read and written to at high speed.
- Power-down operating mode
The power supply circuit of flash memory can be partly halted. As a result, flash memory can be read with low power consumption.
- Standby mode
All flash memory circuits are halted.

Table 7.7 shows the correspondence between the operating modes of this LSI and the flash memory. In subactive mode, the flash memory can be set to operate in power-down mode with the PDWND bit in FLPWCR. When the flash memory returns to its normal operating state from power-down mode or standby mode, a period to stabilize operation of the power supply circuits that were stopped is needed. When the flash memory returns to its normal operating state, bits STS2 to STS0 in SYSCR1 must be set to provide a wait time of at least 20 μ s, even when the external clock is being used.

Table 7.7 Flash Memory Operating States

| LSI Operating State | Flash Memory Operating State | |
|----------------------------|-------------------------------------|-----------------------|
| | PDWND = 0 (Initial value) | PDWND = 1 |
| Active mode | Normal operating mode | Normal operating mode |
| Subactive mode | Power-down mode | Normal operating mode |
| Sleep mode | Normal operating mode | Normal operating mode |
| Subsleep mode | Standby mode | Standby mode |
| Standby mode | Standby mode | Standby mode |

Section 8 RAM

This LSI has an on-chip high-speed static RAM. The RAM is connected to the CPU by a 16-bit data bus, enabling two-state access by the CPU to both byte data and word data.

| Product Classification | | RAM Size | RAM Address | |
|---|----------------------|------------|-------------------|-------------------|
| Flash memory version (F-ZTAT™ version) | H8/3694F | 2 kbytes | H'F780 to H'FF7F* | |
| Mask-ROM version | H8/3694 | 1 kbyte | H'FB80 to H'FF7F | |
| | H8/3693 | 1 kbyte | H'FB80 to H'FF7F | |
| | H8/3692 | 512 kbytes | H'FD80 to H'FF7F | |
| | H8/3691 | 512 kbytes | H'FD80 to H'FF7F | |
| | H8/3690 | 512 kbytes | H'FD80 to H'FF7F | |
| EEPROM stacked version | Flash memory version | H8/3694N | 2 kbytes | H'F780 to H'FF7F* |
| | Mask-ROM version | | 1 kbyte | H'FB80 to H'FF7F |

Note: * When the E7 or E8 is used, area H'F780 to H'FB7F must not be accessed.

Section 9 I/O Ports

The group of this LSI has twenty-nine general I/O ports (twenty-seven general I/O ports in the H8/3694N) and eight general input-only ports. Port 8 is a large current port, which can drive 20 mA (@ $V_{OL} = 1.5$ V) when a low level signal is output. Any of these ports can become an input port immediately after a reset. They can also be used as I/O pins of the on-chip peripheral modules or external interrupt input pins, and these functions can be switched depending on the register settings. The registers for selecting these functions can be divided into two types: those included in I/O ports and those included in each on-chip peripheral module. General I/O ports are comprised of the port control register for controlling inputs/outputs and the port data register for storing output data and can select inputs/outputs in bit units. For functions in each port, see appendix B.1, I/O Port Block Diagrams. For the execution of bit manipulation instructions to the port control register and port data register, see section 2.8.3, Bit Manipulation Instruction.

9.1 Port 1

Port 1 is a general I/O port also functioning as IRQ interrupt input pins, a timer A output pin, and a timer V input pin. Figure 9.1 shows its pin configuration.

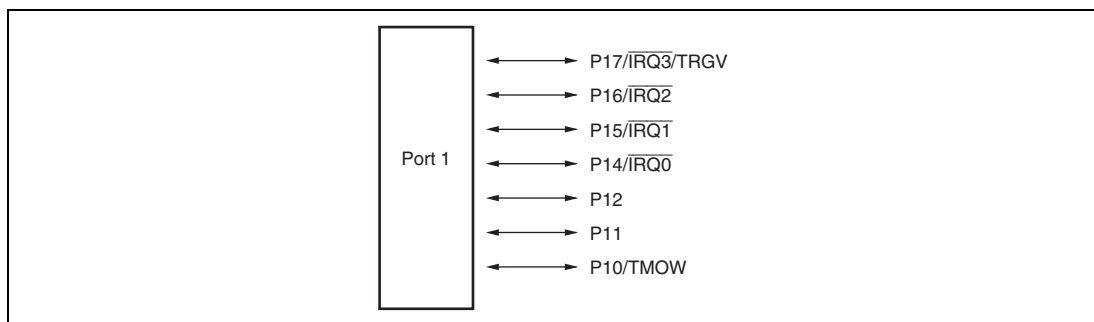

Figure 9.1 Port 1 Pin Configuration

Port 1 has the following registers.

- Port mode register 1 (PMR1)
- Port control register 1 (PCR1)
- Port data register 1 (PDR1)
- Port pull-up control register 1 (PUCR1)

9.1.1 Port Mode Register 1 (PMR1)

PMR1 switches the functions of pins in port 1 and port 2.

| Bit | Bit Name | Initial Value | R/W | Description |
|------|----------|---------------|-----|--|
| 7 | IRQ3 | 0 | R/W | P17/ $\overline{\text{IRQ3}}$ /TRGV Pin Function Switch This bit selects whether pin P17/ $\overline{\text{IRQ3}}$ /TRGV is used as P17 or as $\overline{\text{IRQ3}}$ /TRGV. 0: General I/O port 1: $\overline{\text{IRQ3}}$ /TRGV input pin |
| 6 | IRQ2 | 0 | R/W | P16/ $\overline{\text{IRQ2}}$ Pin Function Switch This bit selects whether pin P16/ $\overline{\text{IRQ2}}$ is used as P16 or as IRQ2. 0: General I/O port 1: $\overline{\text{IRQ2}}$ input pin |
| 5 | IRQ1 | 0 | R/W | P15/ $\overline{\text{IRQ1}}$ Pin Function Switch This bit selects whether pin P15/ $\overline{\text{IRQ1}}$ is used as P15 or as $\overline{\text{IRQ1}}$. 0: General I/O port 1: $\overline{\text{IRQ1}}$ input pin |
| 4 | IRQ0 | 0 | R/W | P14/ $\overline{\text{IRQ0}}$ Pin Function Switch This bit selects whether pin P14/ $\overline{\text{IRQ0}}$ is used as P14 or as $\overline{\text{IRQ0}}$. 0: General I/O port 1: $\overline{\text{IRQ0}}$ input pin |
| 3, 2 | — | All 1 | — | Reserved These bits are always read as 1. |
| 1 | TXD | 0 | R/W | P22/TXD Pin Function Switch This bit selects whether pin P22/TXD is used as P22 or as TXD. 0: General I/O port 1: TXD output pin |
| 0 | TMOW | 0 | R/W | P10/TMOW Pin Function Switch This bit selects whether pin P10/TMOW is used as P10 or as TMOW. 0: General I/O port 1: TMOW output pin |

9.1.2 Port Control Register 1 (PCR1)

PCR1 selects inputs/outputs in bit units for pins to be used as general I/O ports of port 1.

| Bit | Bit Name | Initial Value | R/W | Description |
|-----|----------|---------------|-----|---|
| 7 | PCR17 | 0 | W | When the corresponding pin is designated in PMR1 as a general I/O pin, setting a PCR1 bit to 1 makes the corresponding pin an output port, while clearing the bit to 0 makes the pin an input port. |
| 6 | PCR16 | 0 | W | |
| 5 | PCR15 | 0 | W | Bit 3 is a reserved bit. |
| 4 | PCR14 | 0 | W | |
| 3 | — | — | — | |
| 2 | PCR12 | 0 | W | |
| 1 | PCR11 | 0 | W | |
| 0 | PCR10 | 0 | W | |

9.1.3 Port Data Register 1 (PDR1)

PDR1 is a general I/O port data register of port 1.

| Bit | Bit Name | Initial Value | R/W | Description |
|-----|----------|---------------|-----|--|
| 7 | P17 | 0 | R/W | PDR1 stores output data for port 1 pins. |
| 6 | P16 | 0 | R/W | If PDR1 is read while PCR1 bits are set to 1, the value stored in PDR1 are read. If PDR1 is read while PCR1 bits are cleared to 0, the pin states are read regardless of the value stored in PDR1. |
| 5 | P15 | 0 | R/W | |
| 4 | P14 | 0 | R/W | Bit 3 is a reserved bit. This bit is always read as 1. |
| 3 | — | 1 | — | |
| 2 | P12 | 0 | R/W | |
| 1 | P11 | 0 | R/W | |
| 0 | P10 | 0 | R/W | |

9.1.4 Port Pull-Up Control Register 1 (PUCR1)

PUCR1 controls the pull-up MOS in bit units of the pins set as the input ports.

| Bit | Bit Name | Initial Value | R/W | Description |
|-----|----------|---------------|-----|--|
| 7 | PUCR17 | 0 | R/W | Only bits for which PCR1 is cleared are valid. The pull-up MOS of P17 to P14 and P12 to P10 pins enter the on-state when these bits are set to 1, while they enter the off-state when these bits are cleared to 0. |
| 6 | PUCR16 | 0 | R/W | |
| 5 | PUCR15 | 0 | R/W | Bit 3 is a reserved bit. This bit is always read as 1. |
| 4 | PUCR14 | 0 | R/W | |
| 3 | — | 1 | — | |
| 2 | PUCR12 | 0 | R/W | |
| 1 | PUCR11 | 0 | R/W | |
| 0 | PUCR10 | 0 | R/W | |

9.1.5 Pin Functions

The correspondence between the register specification and the port functions is shown below.

P17/ $\overline{\text{IRQ3}}$ /TRGV pin

| Register | PMR1 | PCR1 | |
|-----------------|------|-------|---|
| Bit Name | IRQ3 | PCR17 | Pin Function |
| Setting value 0 | | 0 | P17 input pin |
| | | 1 | P17 output pin |
| 1 | | X | $\overline{\text{IRQ3}}$ input/TRGV input pin |

Legend: X: Don't care.

P16/ $\overline{\text{IRQ2}}$ pin

| Register | PMR1 | PCR1 | |
|-----------------|------|-------|------------------------------------|
| Bit Name | IRQ2 | PCR16 | Pin Function |
| Setting value 0 | | 0 | P16 input pin |
| | | 1 | P16 output pin |
| 1 | | X | $\overline{\text{IRQ2}}$ input pin |

Legend: X: Don't care.

P15/ $\overline{\text{IRQ1}}$ pin

| Register | PMR1 | PCR1 | |
|---------------|------|-------|------------------------------------|
| Bit Name | IRQ1 | PCR15 | Pin Function |
| Setting value | 0 | 0 | P15 input pin |
| | | 1 | P15 output pin |
| | 1 | X | $\overline{\text{IRQ1}}$ input pin |

Legend: X: Don't care.

P14/ $\overline{\text{IRQ0}}$ pin

| Register | PMR1 | PCR1 | |
|---------------|------|-------|------------------------------------|
| Bit Name | IRQ0 | PCR14 | Pin Function |
| Setting value | 0 | 0 | P14 input pin |
| | | 1 | P14 output pin |
| | 1 | X | $\overline{\text{IRQ0}}$ input pin |

Legend: X: Don't care.

P12 pin

| Register | PCR1 | |
|---------------|-------|----------------|
| Bit Name | PCR12 | Pin Function |
| Setting value | 0 | P12 input pin |
| | 1 | P12 output pin |

P11 pin

| Register | PCR1 | |
|---------------|-------|----------------|
| Bit Name | PCR11 | Pin Function |
| Setting value | 0 | P11 input pin |
| | 1 | P11 output pin |

P10/TMOW pin

| Register | PMR1 | PCR1 | |
|---------------|------|-------|-----------------|
| Bit Name | TMOW | PCR10 | Pin Function |
| Setting value | 0 | 0 | P10 input pin |
| | | 1 | P10 output pin |
| | 1 | X | TMOW output pin |

Legend: X: Don't care.

9.2 Port 2

Port 2 is a general I/O port also functioning as a SCI3 I/O pin. Each pin of the port 2 is shown in figure 9.2. The register settings of PMR1 and SCI3 have priority for functions of the pins for both uses.

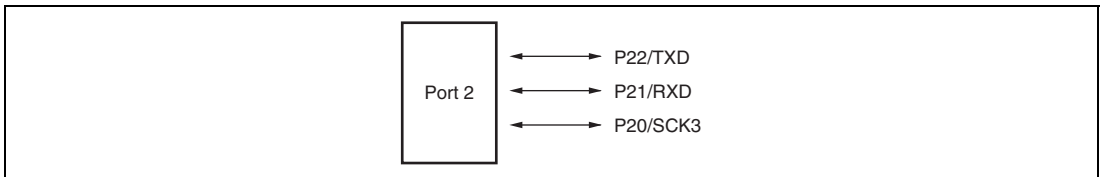

Figure 9.2 Port 2 Pin Configuration

Port 2 has the following registers.

- Port control register 2 (PCR2)
- Port data register 2 (PDR2)

9.2.1 Port Control Register 2 (PCR2)

PCR2 selects inputs/outputs in bit units for pins to be used as general I/O ports of port 2.

| Bit | Bit Name | Initial Value | R/W | Description |
|--------|----------|---------------|-----|--|
| 7 to 3 | — | — | — | Reserved |
| 2 | PCR22 | 0 | W | When each of the port 2 pins P22 to P20 functions as an general I/O port, setting a PCR2 bit to 1 makes the corresponding pin an output port, while clearing the bit to 0 makes the pin an input port. |
| 1 | PCR21 | 0 | W | |
| 0 | PCR20 | 0 | W | |

9.2.2 Port Data Register 2 (PDR2)

PDR2 is a general I/O port data register of port 2.

| Bit | Bit Name | Initial Value | R/W | Description |
|--------|----------|---------------|-----|---|
| 7 to 3 | — | All 1 | — | Reserved These bits are always read as 1. |
| 2 | P22 | 0 | R/W | PDR2 stores output data for port 2 pins. |
| 1 | P21 | 0 | R/W | If PDR2 is read while PCR2 bits are set to 1, the value stored in PDR2 is read. If PDR2 is read while PCR2 bits are cleared to 0, the pin states are read regardless of the value stored in PDR2. |
| 0 | P20 | 0 | R/W | |

9.2.3 Pin Functions

The correspondence between the register specification and the port functions is shown below.

P22/TXD pin

| Register | PMR1 | PCR2 | |
|---------------|------|-------|----------------|
| Bit Name | TXD | PCR22 | Pin Function |
| Setting Value | 0 | 0 | P22 input pin |
| | | 1 | P22 output pin |
| | 1 | X | TXD output pin |

Legend: X: Don't care.

P21/RXD pin

| Register | SCR3 | PCR2 | |
|---------------|------|-------|----------------|
| Bit Name | RE | PCR21 | Pin Function |
| Setting Value | 0 | 0 | P21 input pin |
| | | 1 | P21 output pin |
| | 1 | X | RXD input pin |

Legend: X: Don't care.

P20/SCK3 pin

| Register | SCR3 | | SMR | PCR2 | |
|---------------|------|------|-----|-------|-----------------|
| Bit Name | CKE1 | CKE0 | COM | PCR20 | Pin Function |
| Setting Value | 0 | 0 | 0 | 0 | P20 input pin |
| | | | | 1 | P20 output pin |
| | 0 | 0 | 1 | X | SCK3 output pin |
| | 0 | 1 | X | X | SCK3 output pin |
| | 1 | X | X | X | SCK3 input pin |

Legend: X: Don't care.

9.3 Port 5

Port 5 is a general I/O port also functioning as an I²C bus interface I/O pin, an A/D trigger input pin, wakeup interrupt input pin. Each pin of the port 5 is shown in figure 9.3. The register setting of the I²C bus interface register has priority for functions of the pins P57/SCL and P56/SDA. Since the output buffer for pins P56 and P57 has the NMOS push-pull structure, it differs from an output buffer with the CMOS structure in the high-level output characteristics (see section 21, Electrical Characteristics).

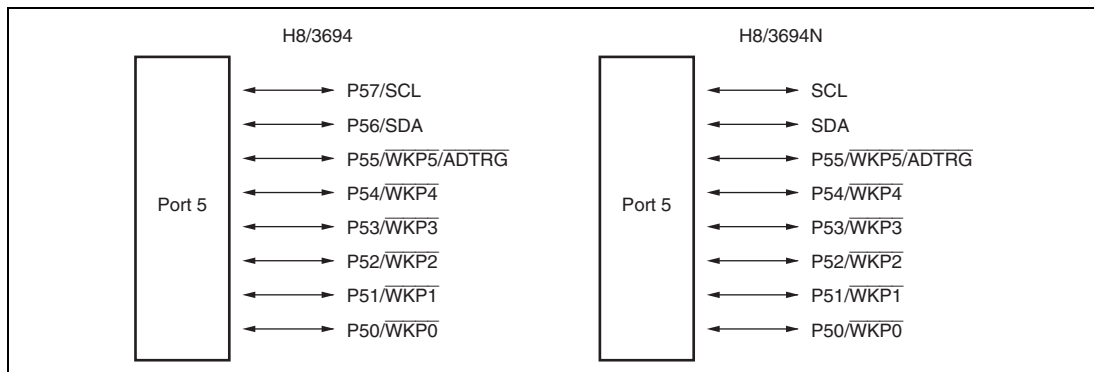

Figure 9.3 Port 5 Pin Configuration

Port 5 has the following registers.

- Port mode register 5 (PMR5)
- Port control register 5 (PCR5)
- Port data register 5 (PDR5)
- Port pull-up control register 5 (PUCR5)

9.3.1 Port Mode Register 5 (PMR5)

PMR5 switches the functions of pins in port 5.

| Bit | Bit Name | Initial Value | R/W | Description |
|------|----------|---------------|-----|---|
| 7, 6 | — | All 0 | — | Reserved These bits are always read as 0. |
| 5 | WKP5 | 0 | R/W | P55/ $\overline{\text{WKP5}}$ /ADTRG Pin Function Switch Selects whether pin P55/ $\overline{\text{WKP5}}$ /ADTRG is used as P55 or as $\overline{\text{WKP5}}$ /ADTRG input. 0: General I/O port 1: $\overline{\text{WKP5}}$ /ADTRG input pin |
| 4 | WKP4 | 0 | R/W | P54/ $\overline{\text{WKP4}}$ Pin Function Switch Selects whether pin P54/ $\overline{\text{WKP4}}$ is used as P54 or as $\overline{\text{WKP4}}$. 0: General I/O port 1: $\overline{\text{WKP4}}$ input pin |
| 3 | WKP3 | 0 | R/W | P53/ $\overline{\text{WKP3}}$ Pin Function Switch Selects whether pin P53/ $\overline{\text{WKP3}}$ is used as P53 or as $\overline{\text{WKP3}}$. 0: General I/O port 1: $\overline{\text{WKP3}}$ input pin |
| 2 | WKP2 | 0 | R/W | P52/ $\overline{\text{WKP2}}$ Pin Function Switch Selects whether pin P52/ $\overline{\text{WKP2}}$ is used as P52 or as $\overline{\text{WKP2}}$. 0: General I/O port 1: $\overline{\text{WKP2}}$ input pin |
| 1 | WKP1 | 0 | R/W | P51/ $\overline{\text{WKP1}}$ Pin Function Switch Selects whether pin P51/ $\overline{\text{WKP1}}$ is used as P51 or as $\overline{\text{WKP1}}$. 0: General I/O port 1: $\overline{\text{WKP1}}$ input pin |
| 0 | WKP0 | 0 | R/W | P50/ $\overline{\text{WKP0}}$ Pin Function Switch Selects whether pin P50/ $\overline{\text{WKP0}}$ is used as P50 or as $\overline{\text{WKP0}}$. 0: General I/O port 1: $\overline{\text{WKP0}}$ input pin |

9.3.2 Port Control Register 5 (PCR5)

PCR5 selects inputs/outputs in bit units for pins to be used as general I/O ports of port 5.

| Bit | Bit Name | Initial Value | R/W | Description |
|-----|----------|---------------|-----|--|
| 7 | PCR57 | 0 | W | When each of the port 5 pins P57 to P50 functions as an general I/O port, setting a PCR5 bit to 1 makes the corresponding pin an output port, while clearing the bit to 0 makes the pin an input port. Note: The PCR57 and PCR56 bits should not be set to 1 in the H8/3694N. |
| 6 | PCR56 | 0 | W | |
| 5 | PCR55 | 0 | W | |
| 4 | PCR54 | 0 | W | |
| 3 | PCR53 | 0 | W | |
| 2 | PCR52 | 0 | W | |
| 1 | PCR51 | 0 | W | |
| 0 | PCR50 | 0 | W | |

9.3.3 Port Data Register 5 (PDR5)

PDR5 is a general I/O port data register of port 5.

| Bit | Bit Name | Initial Value | R/W | Description |
|-----|----------|---------------|-----|--|
| 7 | P57 | 0 | R/W | Stores output data for port 5 pins. |
| 6 | P56 | 0 | R/W | If PDR5 is read while PCR5 bits are set to 1, the value stored in PDR5 are read. If PDR5 is read while PCR5 bits are cleared to 0, the pin states are read regardless of the value stored in PDR5. Note: The P57 and P56 bits should not be set to 1 in the H8/3694N. |
| 5 | P55 | 0 | R/W | |
| 4 | P54 | 0 | R/W | |
| 3 | P53 | 0 | R/W | |
| 2 | P52 | 0 | R/W | |
| 1 | P51 | 0 | R/W | |
| 0 | P50 | 0 | R/W | |

9.3.4 Port Pull-Up Control Register 5 (PUCR5)

PUCR5 controls the pull-up MOS in bit units of the pins set as the input ports.

| Bit | Bit Name | Initial Value | R/W | Description |
|------|----------|---------------|-----|--|
| 7, 6 | — | All 0 | — | Reserved These bits are always read as 0. |
| 5 | PUCR55 | 0 | R/W | Only bits for which PCR5 is cleared are valid. The pull-up MOS of the corresponding pins enter the on-state when these bits are set to 1, while they enter the off-state when these bits are cleared to 0. |
| 4 | PUCR54 | 0 | R/W | |
| 3 | PUCR53 | 0 | R/W | |
| 2 | PUCR52 | 0 | R/W | |
| 1 | PUCR51 | 0 | R/W | |
| 0 | PUCR50 | 0 | R/W | |

9.3.5 Pin Functions

The correspondence between the register specification and the port functions is shown below.

P57/SCL pin

| Register | ICCR1 | PCR5 | |
|---------------|-------|-------|----------------|
| Bit Name | ICE | PCR57 | Pin Function |
| Setting Value | 0 | 0 | P57 input pin |
| | | 1 | P57 output pin |
| | 1 | X | SCL I/O pin |

Legend: X: Don't care.

SCL performs the NMOS open-drain output, that enables a direct bus drive.

P56/SDA pin

| Register | ICCR1 | PCR5 | |
|---------------|-------|-------|----------------|
| Bit Name | ICE | PCR56 | Pin Function |
| Setting Value | 0 | 0 | P56 input pin |
| | | 1 | P56 output pin |
| | 1 | X | SDA I/O pin |

Legend: X: Don't care.

SDA performs the NMOS open-drain output, that enables a direct bus drive.

P55/ $\overline{WKP5}$ / \overline{ADTRG} pin

| Register | PMR5 | PCR5 | |
|---------------|------|-------|--|
| Bit Name | WKP5 | PCR55 | Pin Function |
| Setting Value | 0 | 0 | P55 input pin |
| | | 1 | P55 output pin |
| | 1 | X | $\overline{WKP5}/\overline{ADTRG}$ input pin |

Legend: X: Don't care.

P54/ $\overline{WKP4}$ pin

| Register | PMR5 | PCR5 | |
|---------------|------|-------|-----------------------------|
| Bit Name | WKP4 | PCR54 | Pin Function |
| Setting Value | 0 | 0 | P54 input pin |
| | | 1 | P54 output pin |
| | 1 | X | $\overline{WKP4}$ input pin |

Legend: X: Don't care.

P53/WKP3 pin

| Register | PMR5 | PCR5 | |
|---------------|------|-------|------------------------------------|
| Bit Name | WKP3 | PCR53 | Pin Function |
| Setting Value | 0 | 0 | P53 input pin |
| | | 1 | P53 output pin |
| | 1 | X | $\overline{\text{WKP3}}$ input pin |

Legend: X: Don't care.

P52/WKP2 pin

| Register | PMR5 | PCR5 | |
|---------------|------|-------|------------------------------------|
| Bit Name | WKP2 | PCR52 | Pin Function |
| Setting Value | 0 | 0 | P52 input pin |
| | | 1 | P52 output pin |
| | 1 | X | $\overline{\text{WKP2}}$ input pin |

Legend: X: Don't care.

P51/WKP1 pin

| Register | PMR5 | PCR5 | |
|---------------|------|-------|------------------------------------|
| Bit Name | WKP1 | PCR51 | Pin Function |
| Setting Value | 0 | 0 | P51 input pin |
| | | 1 | P51 output pin |
| | 1 | X | $\overline{\text{WKP1}}$ input pin |

Legend: X: Don't care.

P50/WKP0 pin

| Register | PMR5 | PCR5 | |
|---------------|------|-------|----------------|
| Bit Name | WKP0 | PCR50 | Pin Function |
| Setting Value | 0 | 0 | P50 input pin |
| | | 1 | P50 output pin |
| | 1 | X | WKP0 input pin |

Legend: X: Don't care.

9.4 Port 7

Port 7 is a general I/O port also functioning as a timer V I/O pin. Each pin of the port 7 is shown in figure 9.4. The register setting of TCSR_V in timer V has priority for functions of pin P76/TMOV. The pins, P75/TMCIV and P74/TMRIV, are also functioning as timer V input ports that are connected to the timer V regardless of the register setting of port 7.

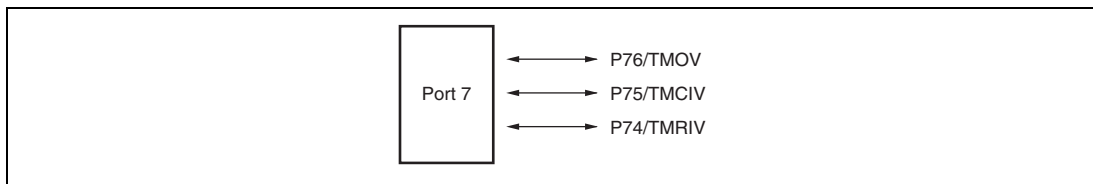

Figure 9.4 Port 7 Pin Configuration

Port 7 has the following registers.

- Port control register 7 (PCR7)
- Port data register 7 (PDR7)

9.4.1 Port Control Register 7 (PCR7)

PCR7 selects inputs/outputs in bit units for pins to be used as general I/O ports of port 7.

| Bit | Bit Name | Initial Value | R/W | Description |
|--------|----------|---------------|-----|--|
| 7 | — | — | — | Reserved |
| 6 | PCR76 | 0 | W | Setting a PCR7 bit to 1 makes the corresponding pin an output port, while clearing the bit to 0 makes the pin an input port. Note that the TCSR.V setting of the timer V has priority for deciding input/output direction of the P76/TMOV pin. |
| 5 | PCR75 | 0 | W | |
| 4 | PCR74 | 0 | W | |
| 3 to 0 | — | — | — | Reserved |

9.4.2 Port Data Register 7 (PDR7)

PDR7 is a general I/O port data register of port 7.

| Bit | Bit Name | Initial Value | R/W | Description |
|--------|----------|---------------|-----|---|
| 7 | — | 1 | — | Reserved This bit is always read as 1. |
| 6 | P76 | 0 | R/W | PDR7 stores output data for port 7 pins. |
| 5 | P75 | 0 | R/W | If PDR7 is read while PCR7 bits are set to 1, the value stored in PDR7 is read. If PDR7 is read while PCR7 bits are cleared to 0, the pin states are read regardless of the value stored in PDR7. |
| 4 | P74 | 0 | R/W | |
| 3 to 0 | — | All 1 | — | Reserved These bits are always read as 1. |

9.4.3 Pin Functions

The correspondence between the register specification and the port functions is shown below.

P76/TMOV pin

| Register | TCSR.V | PCR7 | |
|---------------|-----------------------------|-------|-----------------|
| Bit Name | OS3 to OS0 | PCR76 | Pin Function |
| Setting Value | 0000 | 0 | P76 input pin |
| | | 1 | P76 output pin |
| | Other than the above values | X | TMOV output pin |

Legend: X: Don't care.

P75/TMCIV pin

| Register | PCR7 | |
|---------------|-------|----------------------------|
| Bit Name | PCR75 | Pin Function |
| Setting Value | 0 | P75 input/TMCIV input pin |
| | 1 | P75 output/TMCIV input pin |

P74/TMRIV pin

| Register | PCR7 | |
|---------------|-------|----------------------------|
| Bit Name | PCR74 | Pin Function |
| Setting Value | 0 | P74 input/TMRIV input pin |
| | 1 | P74 output/TMRIV input pin |

9.5 Port 8

Port 8 is a general I/O port also functioning as a timer W I/O pin. Each pin of the port 8 is shown in figure 9.5. The register setting of the timer W has priority for functions of the pins P84/FTIOD, P83/FTIOC, P82/FTIOB, and P81/FTIOA. P80/FTCI also functions as a timer W input port that is connected to the timer W regardless of the register setting of port 8.

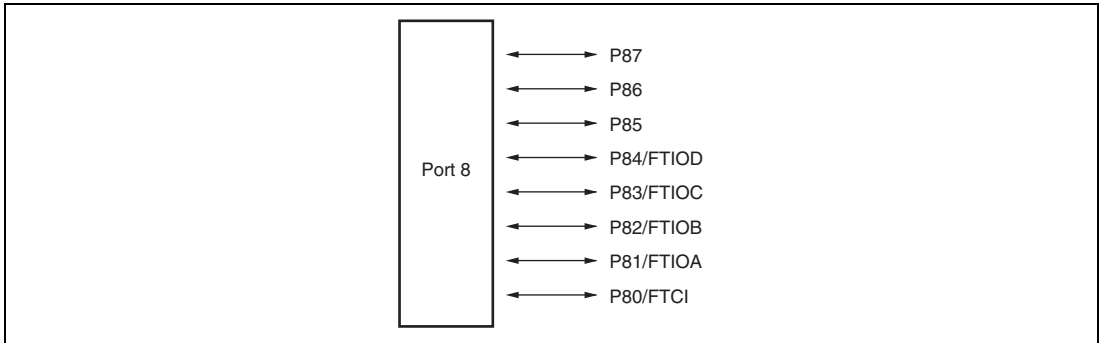

Figure 9.5 Port 8 Pin Configuration

Port 8 has the following registers.

- Port control register 8 (PCR8)
- Port data register 8 (PDR8)

9.5.1 Port Control Register 8 (PCR8)

PCR8 selects inputs/outputs in bit units for pins to be used as general I/O ports of port 8.

| Bit | Bit Name | Initial Value | R/W | Description |
|-----|----------|---------------|-----|--|
| 7 | PCR87 | 0 | W | When each of the port 8 pins P87 to P80 functions as an general I/O port, setting a PCR8 bit to 1 makes the corresponding pin an output port, while clearing the bit to 0 makes the pin an input port. |
| 6 | PCR86 | 0 | W | |
| 5 | PCR85 | 0 | W | |
| 4 | PCR84 | 0 | W | |
| 3 | PCR83 | 0 | W | |
| 2 | PCR82 | 0 | W | |
| 1 | PCR81 | 0 | W | |
| 0 | PCR80 | 0 | W | |

9.5.2 Port Data Register 8 (PDR8)

PDR8 is a general I/O port data register of port 8.

| Bit | Bit Name | Initial Value | R/W | Description |
|-----|----------|---------------|-----|---|
| 7 | P87 | 0 | R/W | PDR8 stores output data for port 8 pins. |
| 6 | P86 | 0 | R/W | If PDR8 is read while PCR8 bits are set to 1, the value stored in PDR8 is read. If PDR8 is read while PCR8 bits are cleared to 0, the pin states are read regardless of the value stored in PDR8. |
| 5 | P85 | 0 | R/W | |
| 4 | P84 | 0 | R/W | |
| 3 | P83 | 0 | R/W | |
| 2 | P82 | 0 | R/W | |
| 1 | P81 | 0 | R/W | |
| 0 | P80 | 0 | R/W | |

9.5.3 Pin Functions

The correspondence between the register specification and the port functions is shown below.

P87 pin

| Register | PCR8 | |
|---------------|-------|----------------|
| Bit Name | PCR87 | Pin Function |
| Setting Value | 0 | P87 input pin |
| | 1 | P87 output pin |

P86 pin

| Register | PCR8 | |
|---------------|-------|----------------|
| Bit Name | PCR86 | Pin Function |
| Setting Value | 0 | P86 input pin |
| | 1 | P86 output pin |

P85 pin

| Register | PCR8 | |
|---------------|-------|----------------|
| Bit Name | PCR85 | Pin Function |
| Setting Value | 0 | P85 input pin |
| | 1 | P85 output pin |

P84/FTIOD pin

| Register | TIOR1 | | | PCR8 | |
|---------------|-------|------|------|-------|----------------------------|
| Bit Name | IOD2 | IOD1 | IOD0 | PCR84 | Pin Function |
| Setting Value | 0 | 0 | 0 | 0 | P84 input/FTIOD input pin |
| | | | | 1 | P84 output/FTIOD input pin |
| | 0 | 0 | 1 | X | FTIOD output pin |
| | | | | X | FTIOD output pin |
| | 1 | X | X | 0 | P84 input/FTIOD input pin |
| | | | | 1 | P84 output/FTIOD input pin |

Legend: X: Don't care.

P83/FTIOC pin

| Register | TIOR1 | | | PCR8 | |
|---------------|-------|------|------|-------|----------------------------|
| Bit Name | IOC2 | IOC1 | IOC0 | PCR83 | Pin Function |
| Setting Value | 0 | 0 | 0 | 0 | P83 input/FTIOC input pin |
| | | | | 1 | P83 output/FTIOC input pin |
| | 0 | 0 | 1 | X | FTIOC output pin |
| | | | | X | FTIOC output pin |
| | 1 | X | X | 0 | P83 input/FTIOC input pin |
| | | | | 1 | P83 output/FTIOC input pin |

Legend: X: Don't care.

P82/FTIOB pin

| Register | TIOR0 | | | PCR8 | | |
|---------------|----------|------|------|------|-------|----------------------------|
| | Bit Name | IOB2 | IOB1 | IOB0 | PCR82 | Pin Function |
| Setting Value | 0 | 0 | 0 | 0 | 0 | P82 input/FTIOB input pin |
| | | | | | 1 | P82 output/FTIOB input pin |
| | 0 | 0 | 1 | X | X | FTIOB output pin |
| | 0 | 1 | X | X | X | FTIOB output pin |
| | 1 | X | X | X | 0 | P82 input/FTIOB input pin |
| | | | | | 1 | P82 output/FTIOB input pin |

Legend: X: Don't care.

P81/FTIOA pin

| Register | TIOR0 | | | PCR8 | | |
|---------------|----------|------|------|------|-------|----------------------------|
| | Bit Name | IOA2 | IOA1 | IOA0 | PCR81 | Pin Function |
| Setting Value | 0 | 0 | 0 | 0 | 0 | P81 input/FTIOA input pin |
| | | | | | 1 | P81 output/FTIOA input pin |
| | 0 | 0 | 1 | X | X | FTIOA output pin |
| | 0 | 1 | X | X | X | FTIOA output pin |
| | 1 | X | X | X | 0 | P81 input/FTIOA input pin |
| | | | | | 1 | P81 output/FTIOA input pin |

Legend: X: Don't care.

P80/FTCI pin

| Register | PCR8 | |
|---------------|-------|---------------------------|
| Bit Name | PCR80 | Pin Function |
| Setting Value | 0 | P80 input/FTCI input pin |
| | 1 | P80 output/FTCI input pin |

9.6 Port B

Port B is an input port also functioning as an A/D converter analog input pin. Each pin of the port B is shown in figure 9.6.

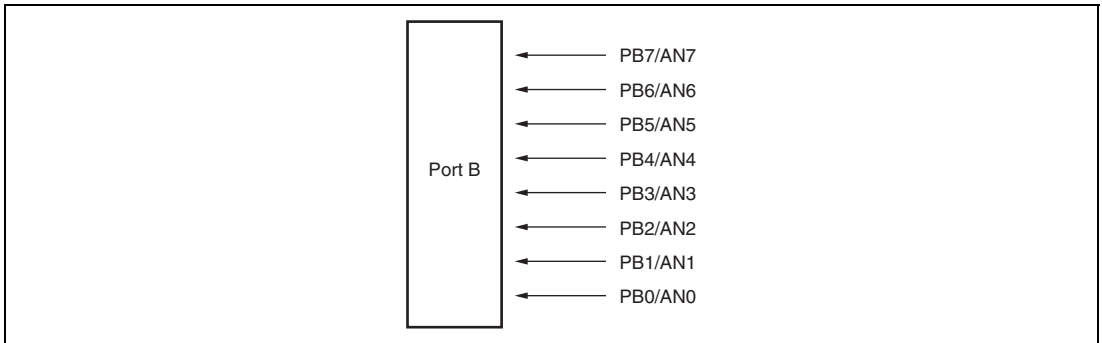

Figure 9.6 Port B Pin Configuration

Port B has the following register.

- Port data register B (PDRB)

9.6.1 Port Data Register B (PDRB)

PDRB is a general input-only port data register of port B.

| Bit | Bit Name | Initial Value | R/W | Description |
|-----|----------|---------------|-----|---|
| 7 | PB7 | — | R | The input value of each pin is read by reading this register. |
| 6 | PB6 | — | R | |
| 5 | PB5 | — | R | However, if a port B pin is designated as an analog input channel by ADCSR in A/D converter, 0 is read. |
| 4 | PB4 | — | R | |
| 3 | PB3 | — | R | |
| 2 | PB2 | — | R | |
| 1 | PB1 | — | R | |
| 0 | PB0 | — | R | |

Section 10 Timer A

Timer A is an 8-bit timer with interval timing and real-time clock time-base functions. The clock time-base function is available when a 32.768kHz crystal oscillator is connected. Figure 10.1 shows a block diagram of timer A.

10.1 Features

- Timer A can be used as an interval timer or a clock time base.
- An interrupt is requested when the counter overflows.
- Any of eight clock signals can be output from pin TMOW: 32.768 kHz divided by 32, 16, 8, or 4 (1 kHz, 2 kHz, 4 kHz, 8 kHz), or the system clock divided by 32, 16, 8, or 4.

Interval Timer

- Choice of eight internal clock sources ($\phi/8192$, $\phi/4096$, $\phi/2048$, $\phi/512$, $\phi/256$, $\phi/128$, $\phi/32$, $\phi/8$)

Clock Time Base

- Choice of four overflow periods (1 s, 0.5 s, 0.25 s, 31.25 ms) when timer A is used as a clock time base (using a 32.768 kHz crystal oscillator).

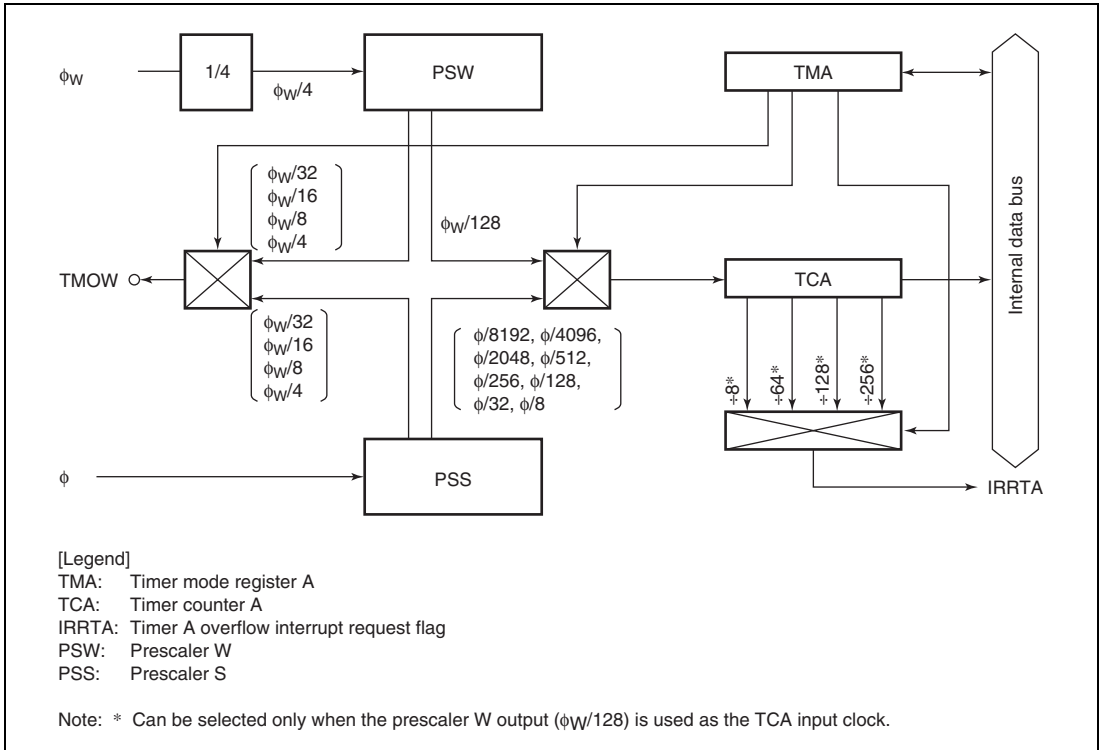

Figure 10.1 Block Diagram of Timer A

10.2 Input/Output Pins

Table 10.1 shows the timer A input/output pin.

Table 10.1 Pin Configuration

| Name | Abbreviation | I/O | Function |
|--------------|--------------|--------|--|
| Clock output | TMOW | Output | Output of waveform generated by timer A output circuit |

10.3 Register Descriptions

Timer A has the following registers.

- Timer mode register A (TMA)
- Timer counter A (TCA)

10.3.1 Timer Mode Register A (TMA)

TMA selects the operating mode, the divided clock output, and the input clock.

| Bit | Bit Name | Initial Value | R/W | Description |
|-----|----------|---------------|-----|--|
| 7 | TMA7 | 0 | R/W | Clock Output Select 7 to 5 |
| 6 | TMA6 | 0 | R/W | These bits select the clock output at the TMOW pin. |
| 5 | TMA5 | 0 | R/W | 000: $\phi/32$ 001: $\phi/16$ 010: $\phi/8$ 011: $\phi/4$ 100: $\phi_w/32$ 101: $\phi_w/16$ 110: $\phi_w/8$ 111: $\phi_w/4$ For details on clock outputs, see section 10.4.3, Clock Output. |
| 4 | — | 1 | — | Reserved This bit is always read as 1. |
| 3 | TMA3 | 0 | R/W | Internal Clock Select 3 This bit selects the operating mode of the timer A. 0: Functions as an interval timer to count the outputs of prescaler S. 1: Functions as a clock-time base to count the outputs of prescaler W. |

| Bit | Bit Name | Initial Value | R/W | Description |
|-----|----------|---------------|-----|---|
| 2 | TMA2 | 0 | R/W | Internal Clock Select 2 to 0 |
| 1 | TMA1 | 0 | R/W | These bits select the clock input to TCA when TMA3 = 0. |
| 0 | TMA0 | 0 | R/W | 000: $\phi/8192$ 001: $\phi/4096$ 010: $\phi/2048$ 011: $\phi/512$ 100: $\phi/256$ 101: $\phi/128$ 110: $\phi/32$ 111: $\phi/8$ These bits select the overflow period when TMA3 = 1 (when a 32.768 kHz crystal oscillator with is used as ϕ W). 000: 1s 001: 0.5 s 010: 0.25 s 011: 0.03125 s 1XX: Both PSW and TCA are reset |

Legend: X: Don't care.

10.3.2 Timer Counter A (TCA)

TCA is an 8-bit readable up-counter, which is incremented by internal clock input. The clock source for input to this counter is selected by bits TMA3 to TMA0 in TMA. TCA values can be read by the CPU in active mode, but cannot be read in subactive mode. When TCA overflows, the IRRTA bit in interrupt request register 1 (IRR1) is set to 1. TCA is cleared by setting bits TMA3 and TMA2 in TMA to B'11. TCA is initialized to H'00.

10.4 Operation

10.4.1 Interval Timer Operation

When bit TMA3 in TMA is cleared to 0, timer A functions as an 8-bit interval timer.

Upon reset, TCA is cleared to H'00 and bit TMA3 is cleared to 0, so up-counting of timer A resume immediately as an interval timer. The clock input to timer A is selected by bits TMA2 to TMA0 in TMA; any of eight internal clock signals output by prescaler S can be selected.

After the count value in TCA reaches H'FF, the next clock signal input causes timer A to overflow, setting bit IRRTA to 1 in interrupt Flag Register 1 (IRR1). If IENTA = 1 in interrupt enable register 1 (IENR1), a CPU interrupt is requested. At overflow, TCA returns to H'00 and starts counting up again. In this mode timer A functions as an interval timer that generates an overflow output at intervals of 256 input clock pulses.

10.4.2 Clock Time Base Operation

When bit TMA3 in TMA is set to 1, timer A functions as a clock-timer base by counting clock signals output by prescaler W. When a clock signal is input after the TCA counter value has become H'FF, timer A overflows and IRRTA in IRR1 is set to 1. At that time, an interrupt request is generated to the CPU if IENTA in the interrupt enable register 1 (IENR1) is 1. The overflow period of timer A is set by bits TMA1 and TMA0 in TMA. A choice of four periods is available. In clock time base operation (TMA3 = 1), setting bit TMA2 to 1 clears both TCA and prescaler W to H'00.

10.4.3 Clock Output

Setting bit TMOW in port mode register 1 (PMR1) to 1 causes a clock signal to be output at pin TMOW. Eight different clock output signals can be selected by means of bits TMA7 to TMA5 in TMA. The system clock divided by 32, 16, 8, or 4 can be output in active mode and sleep mode. A 32.768 kHz signal divided by 32, 16, 8, or 4 can be output in active mode, sleep mode, and subactive mode.

10.5 Usage Note

When the clock time base function is selected as the internal clock of TCA in active mode or sleep mode, the internal clock is not synchronous with the system clock, so it is synchronized by a synchronizing circuit. This may result in a maximum error of $1/\phi$ (s) in the count cycle.

Section 11 Timer V

Timer V is an 8-bit timer based on an 8-bit counter. Timer V counts external events. Compare-match signals with two registers can also be used to reset the counter, request an interrupt, or output a pulse signal with an arbitrary duty cycle. Counting can be initiated by a trigger input at the TRGV pin, enabling pulse output control to be synchronized to the trigger, with an arbitrary delay from the trigger input. Figure 11.1 shows a block diagram of timer V.

11.1 Features

- Choice of seven clock signals is available.
Choice of six internal clock sources ($\phi/128$, $\phi/64$, $\phi/32$, $\phi/16$, $\phi/8$, $\phi/4$) or an external clock.
- Counter can be cleared by compare match A or B, or by an external reset signal. If the count stop function is selected, the counter can be halted when cleared.
- Timer output is controlled by two independent compare match signals, enabling pulse output with an arbitrary duty cycle, PWM output, and other applications.
- Three interrupt sources: compare match A, compare match B, timer overflow
- Counting can be initiated by trigger input at the TRGV pin. The rising edge, falling edge, or both edges of the TRGV input can be selected.

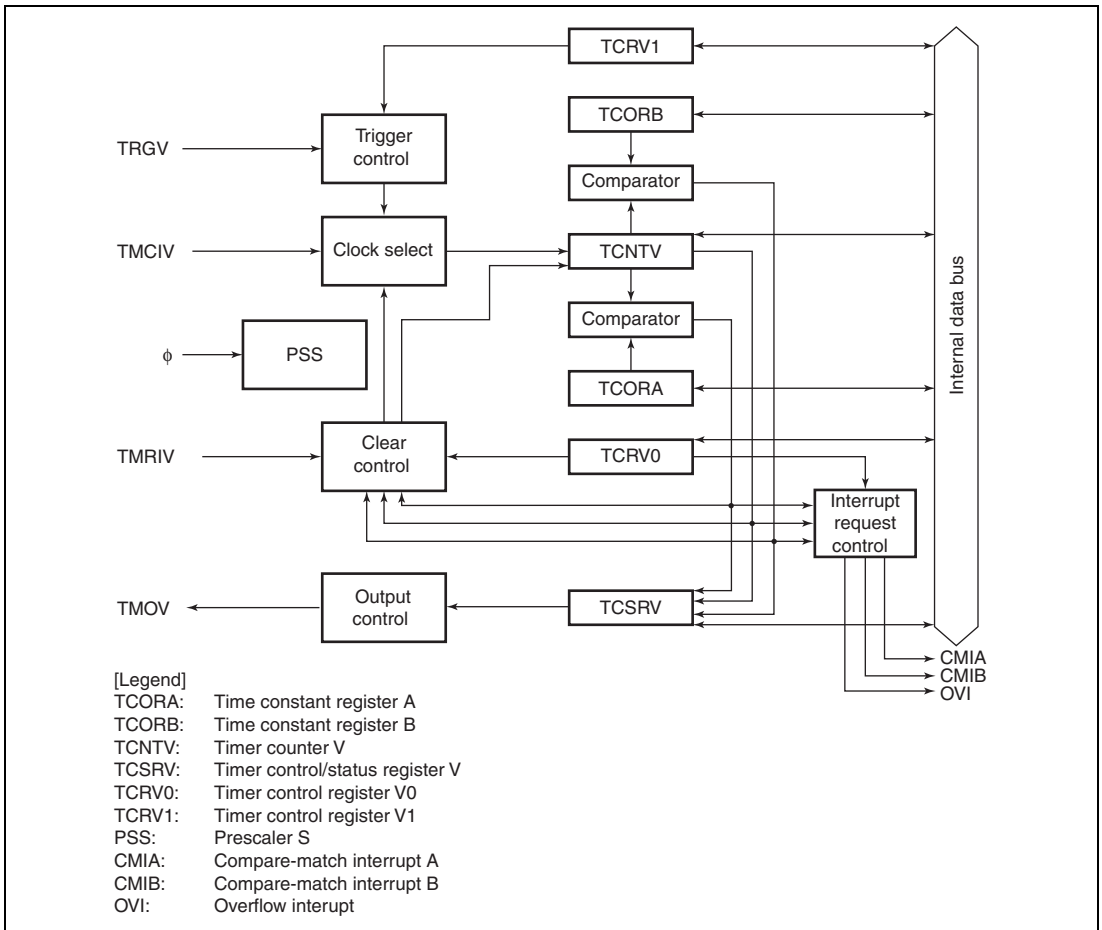

Figure 11.1 Block Diagram of Timer V

11.2 Input/Output Pins

Table 11.1 shows the timer V pin configuration.

Table 11.1 Pin Configuration

| Name | Abbreviation | I/O | Function |
|---------------------|--------------|--------|------------------------------------|
| Timer V output | TMOV | Output | Timer V waveform output |
| Timer V clock input | TMCIV | Input | Clock input to TCNTV |
| Timer V reset input | TMRIV | Input | External input to reset TCNTV |
| Trigger input | TRGV | Input | Trigger input to initiate counting |

11.3 Register Descriptions

Time V has the following registers.

- Timer counter V (TCNTV)
- Timer constant register A (TCORA)
- Timer constant register B (TCORB)
- Timer control register V0 (TCRV0)
- Timer control/status register V (TCSR V)
- Timer control register V1 (TCRV1)

11.3.1 Timer Counter V (TCNTV)

TCNTV is an 8-bit up-counter. The clock source is selected by bits CKS2 to CKS0 in timer control register V0 (TCRV0). The TCNTV value can be read and written by the CPU at any time. TCNTV can be cleared by an external reset input signal, or by compare match A or B. The clearing signal is selected by bits CCLR1 and CCLR0 in TCRV0.

When TCNTV overflows, OVF is set to 1 in timer control/status register V (TCSR V).

TCNTV is initialized to H'00.

11.3.2 Time Constant Registers A and B (TCORA, TCORB)

TCORA and TCORB have the same function.

TCORA and TCORB are 8-bit read/write registers.

TCORA and TCNTV are compared at all times. When the TCORA and TCNTV contents match, CMFA is set to 1 in TCSR V. If CMIEA is also set to 1 in TCRV0, a CPU interrupt is requested. Note that they must not be compared during the T3 state of a TCORA write cycle.

Timer output from the TMOV pin can be controlled by the identifying signal (compare match A) and the settings of bits OS3 to OS0 in TCSR V.

TCORA and TCORB are initialized to H'FF.

11.3.3 Timer Control Register V0 (TCRV0)

TCRV0 selects the input clock signals of TCNTV, specifies the clearing conditions of TCNTV, and controls each interrupt request.

| Bit | Bit Name | Initial Value | R/W | Description |
|-----|----------|---------------|-----|--|
| 7 | CMIEB | 0 | R/W | Compare Match Interrupt Enable B When this bit is set to 1, interrupt request from the CMFB bit in TCSRv is enabled. |
| 6 | CMIEA | 0 | R/W | Compare Match Interrupt Enable A When this bit is set to 1, interrupt request from the CMFA bit in TCSRv is enabled. |
| 5 | OVIE | 0 | R/W | Timer Overflow Interrupt Enable When this bit is set to 1, interrupt request from the OVF bit in TCSRv is enabled. |
| 4 | CCLR1 | 0 | R/W | Counter Clear 1 and 0 |
| 3 | CCLR0 | 0 | R/W | These bits specify the clearing conditions of TCNTV. 00: Clearing is disabled 01: Cleared by compare match A 10: Cleared by compare match B 11: Cleared on the rising edge of the TMRIV pin. The operation of TCNTV after clearing depends on TRGE in TCRV1. |
| 2 | CKS2 | 0 | R/W | Clock Select 2 to 0 |
| 1 | CKS1 | 0 | R/W | These bits select clock signals to input to TCNTV and the counting condition in combination with ICKS0 in TCRV1. |
| 0 | CKS0 | 0 | R/W | Refer to table 11.2. |

Table 11.2 Clock Signals to Input to TCNTV and Counting Conditions

| TCRV0 | | TCRV1 | | Description | |
|-------|-------|-------|-------|---|--|
| Bit 2 | Bit 1 | Bit 0 | Bit 0 | | |
| CKS2 | CKS1 | CKS0 | ICKS0 | | |
| 0 | 0 | 0 | — | Clock input prohibited | |
| | | 1 | 0 | Internal clock: counts on $\phi/4$, falling edge | |
| | | | 1 | Internal clock: counts on $\phi/8$, falling edge | |
| | 1 | 0 | 0 | 0 | Internal clock: counts on $\phi/16$, falling edge |
| | | | | 1 | Internal clock: counts on $\phi/32$, falling edge |
| | | 1 | 0 | 0 | Internal clock: counts on $\phi/64$, falling edge |
| | | | 1 | Internal clock: counts on $\phi/128$, falling edge | |
| 1 | 0 | 0 | — | Clock input prohibited | |
| | | 1 | — | External clock: counts on rising edge | |
| | 1 | 0 | — | External clock: counts on falling edge | |
| | | 1 | — | External clock: counts on rising and falling edge | |

11.3.4 Timer Control/Status Register V (TCSR_V)

TCSR_V indicates the status flag and controls outputs by using a compare match.

| Bit | Bit Name | Initial Value | R/W | Description |
|-----|----------|---------------|-----|---|
| 7 | CMFB | 0 | R/W | Compare Match Flag B Setting condition: When the TCNTV value matches the TCORB value Clearing condition: After reading CMFB = 1, cleared by writing 0 to CMFB |
| 6 | CMFA | 0 | R/W | Compare Match Flag A Setting condition: When the TCNTV value matches the TCORA value Clearing condition: After reading CMFA = 1, cleared by writing 0 to CMFA |
| 5 | OVF | 0 | R/W | Timer Overflow Flag Setting condition: When TCNTV overflows from H'FF to H'00 Clearing condition: After reading OVF = 1, cleared by writing 0 to OVF |
| 4 | — | 1 | — | Reserved This bit is always read as 1. |
| 3 | OS3 | 0 | R/W | Output Select 3 and 2 |
| 2 | OS2 | 0 | R/W | These bits select an output method for the TMOV pin by the compare match of TCORB and TCNTV. 00: No change 01: 0 output 10: 1 output 11: Output toggles |
| 1 | OS1 | 0 | R/W | Output Select 1 and 0 |
| 0 | OS0 | 0 | R/W | These bits select an output method for the TMOV pin by the compare match of TCORA and TCNTV. 00: No change 01: 0 output 10: 1 output 11: Output toggles |

OS3 and OS2 select the output level for compare match B. OS1 and OS0 select the output level for compare match A. The two output levels can be controlled independently. After a reset, the timer output is 0 until the first compare match.

11.3.5 Timer Control Register V1 (TCRV1)

TCRV1 selects the edge at the TRGV pin, enables TRGV input, and selects the clock input to TCNTV.

| Bit | Bit Name | Initial Value | R/W | Description |
|--------|----------|---------------|-----|---|
| 7 to 5 | — | All 1 | — | Reserved These bits are always read as 1. |
| 4 | TVEG1 | 0 | R/W | TRGV Input Edge Select |
| 3 | TVEG0 | 0 | R/W | These bits select the TRGV input edge. 00: TRGV trigger input is prohibited 01: Rising edge is selected 10: Falling edge is selected 11: Rising and falling edges are both selected |
| 2 | TRGE | 0 | R/W | TCNT starts counting up by the input of the edge which is selected by TVEG1 and TVEG0. 0: Disables starting counting-up TCNTV by the input of the TRGV pin and halting counting-up TCNTV when TCNTV is cleared by a compare match. 1: Enables starting counting-up TCNTV by the input of the TRGV pin and halting counting-up TCNTV when TCNTV is cleared by a compare match. |
| 1 | — | 1 | — | Reserved This bit is always read as 1. |
| 0 | ICKS0 | 0 | R/W | Internal Clock Select 0 This bit selects clock signals to input to TCNTV in combination with CKS2 to CKS0 in TCRV0. Refer to table 11.2. |

11.4 Operation

11.4.1 Timer V Operation

1. According to table 11.2, six internal/external clock signals output by prescaler S can be selected as the timer V operating clock signals. When the operating clock signal is selected, TCNTV starts counting-up. Figure 11.2 shows the count timing with an internal clock signal selected, and figure 11.3 shows the count timing with both edges of an external clock signal selected.
2. When TCNTV overflows (changes from H'FF to H'00), the overflow flag (OVF) in TCRV0 will be set. The timing at this time is shown in figure 11.4. An interrupt request is sent to the CPU when OVIE in TCRV0 is 1.
3. TCNTV is constantly compared with TCORA and TCORB. Compare match flag A or B (CMFA or CMFB) is set to 1 when TCNTV matches TCORA or TCORB, respectively. The compare-match signal is generated in the last state in which the values match. Figure 11.5 shows the timing. An interrupt request is generated for the CPU when CMIEA or CMIEB in TCRV0 is 1.
4. When a compare match A or B is generated, the TMOV responds with the output value selected by bits OS3 to OS0 in TCSR.V. Figure 11.6 shows the timing when the output is toggled by compare match A.
5. When CCLR1 or CCLR0 in TCRV0 is 01 or 10, TCNTV can be cleared by the corresponding compare match. Figure 11.7 shows the timing.
6. When CCLR1 or CCLR0 in TCRV0 is 11, TCNTV can be cleared by the rising edge of the input of TMRIV pin. A TMRIV input pulse-width of at least 1.5 system clocks is necessary. Figure 11.8 shows the timing.
7. When a counter-clearing source is generated with TRGE in TCRV1 set to 1, the counting-up is halted as soon as TCNTV is cleared. TCNTV resumes counting-up when the edge selected by TVEG1 or TVEG0 in TCRV1 is input from the TGRV pin.

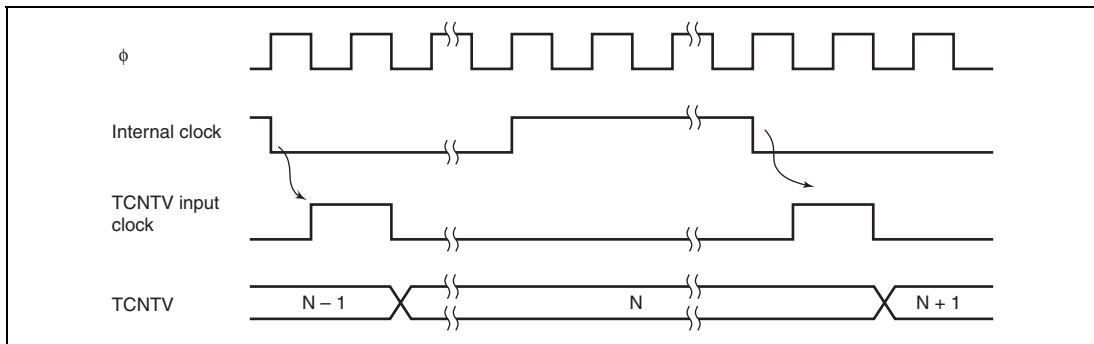

Figure 11.2 Increment Timing with Internal Clock

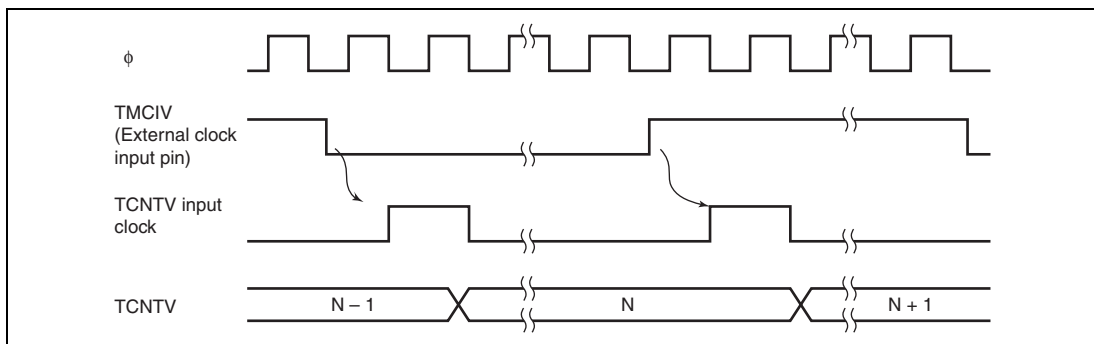

Figure 11.3 Increment Timing with External Clock

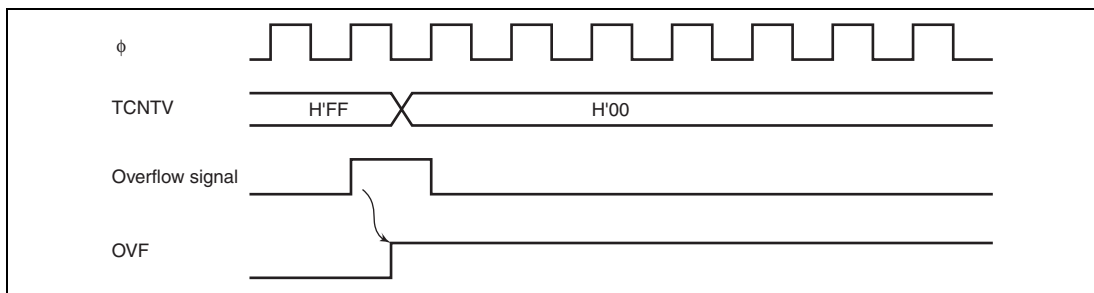

Figure 11.4 OVF Set Timing

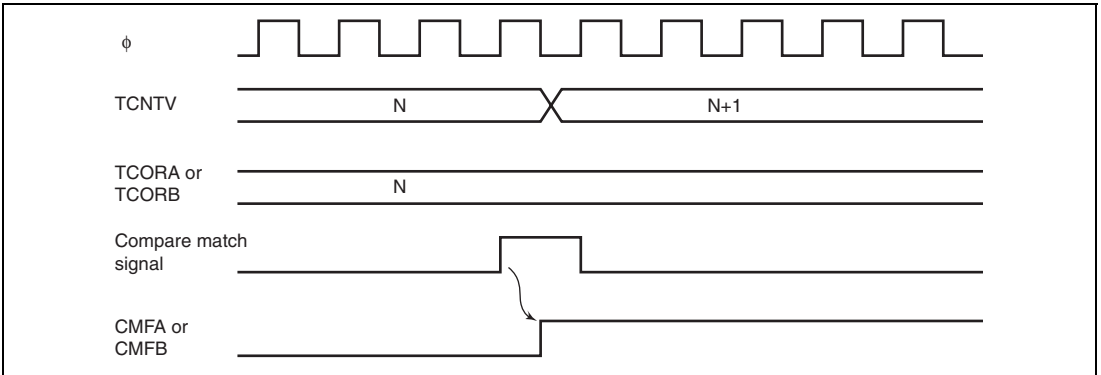

Figure 11.5 CMFA and CMFB Set Timing

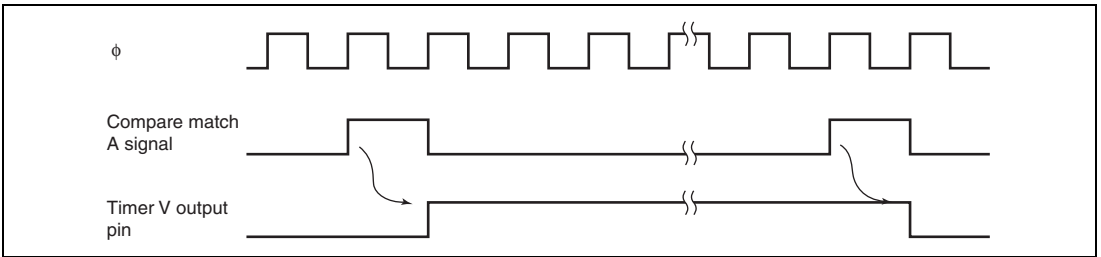

Figure 11.6 TMOV Output Timing

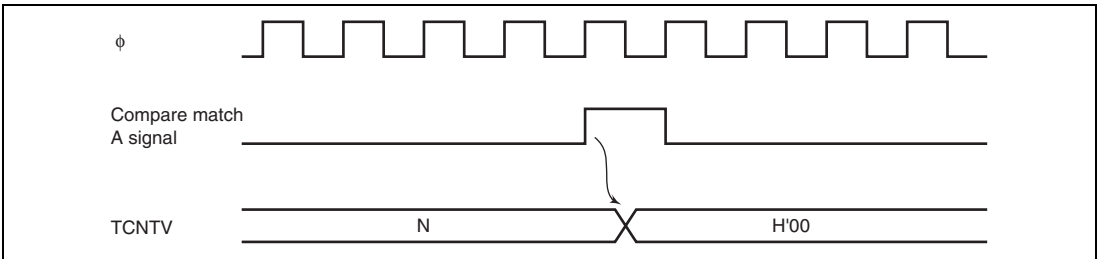
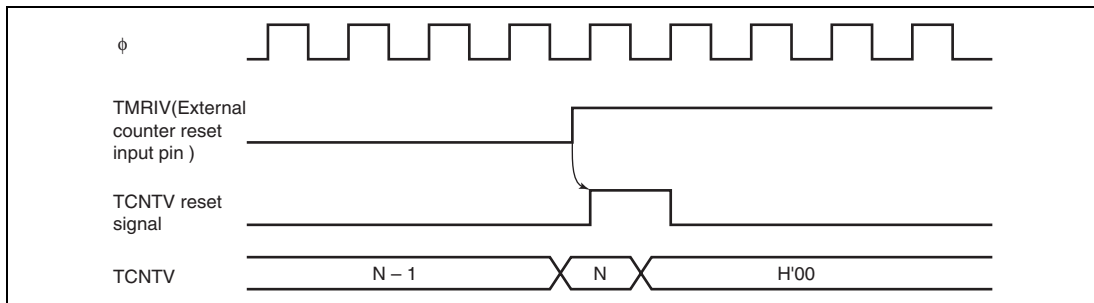

Figure 11.7 Clear Timing by Compare Match

**Figure 11.8 Clear Timing by TMRIV Input**

11.5 Timer V Application Examples

11.5.1 Pulse Output with Arbitrary Duty Cycle

Figure 11.9 shows an example of output of pulses with an arbitrary duty cycle.

1. Set bits CCLR1 and CCLR0 in TCRV0 so that TCNTV will be cleared by compare match with TCORA.
2. Set bits OS3 to OS0 in TCSR0 so that the output will go to 1 at compare match with TCORA and to 0 at compare match with TCORB.
3. Set bits CKS2 to CKS0 in TCRV0 and bit ICKS0 in TCRV1 to select the desired clock source.
4. With these settings, a waveform is output without further software intervention, with a period determined by TCORA and a pulse width determined by TCORB.

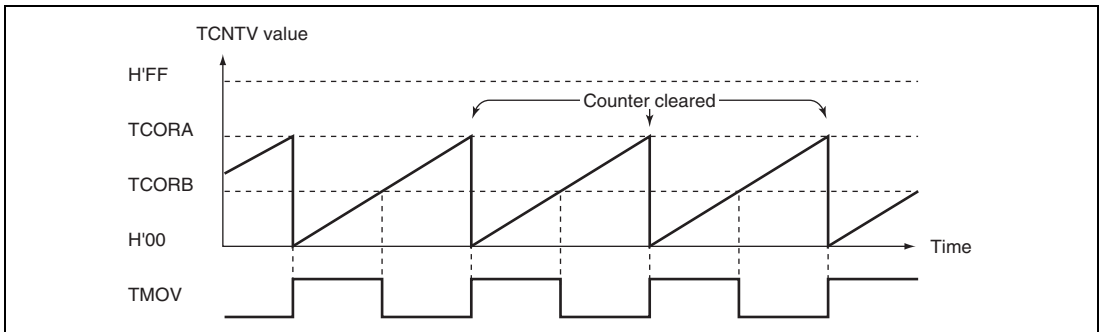

Figure 11.9 Pulse Output Example

11.5.2 Pulse Output with Arbitrary Pulse Width and Delay from TRGV Input

The trigger function can be used to output a pulse with an arbitrary pulse width at an arbitrary delay from the TRGV input, as shown in figure 11.10. To set up this output:

1. Set bits CCLR1 and CCLR0 in TCRV0 so that TCNTV will be cleared by compare match with TCORB.
2. Set bits OS3 to OS0 in TCSR0V so that the output will go to 1 at compare match with TCORA and to 0 at compare match with TCORB.
3. Set bits TVEG1 and TVEG0 in TCRV1 and set TRGE to select the falling edge of the TRGV input.
4. Set bits CKS2 to CKS0 in TCRV0 and bit ICKS0 in TCRV1 to select the desired clock source.
5. After these settings, a pulse waveform will be output without further software intervention, with a delay determined by TCORA from the TRGV input, and a pulse width determined by $(TCORB - TCORA)$.

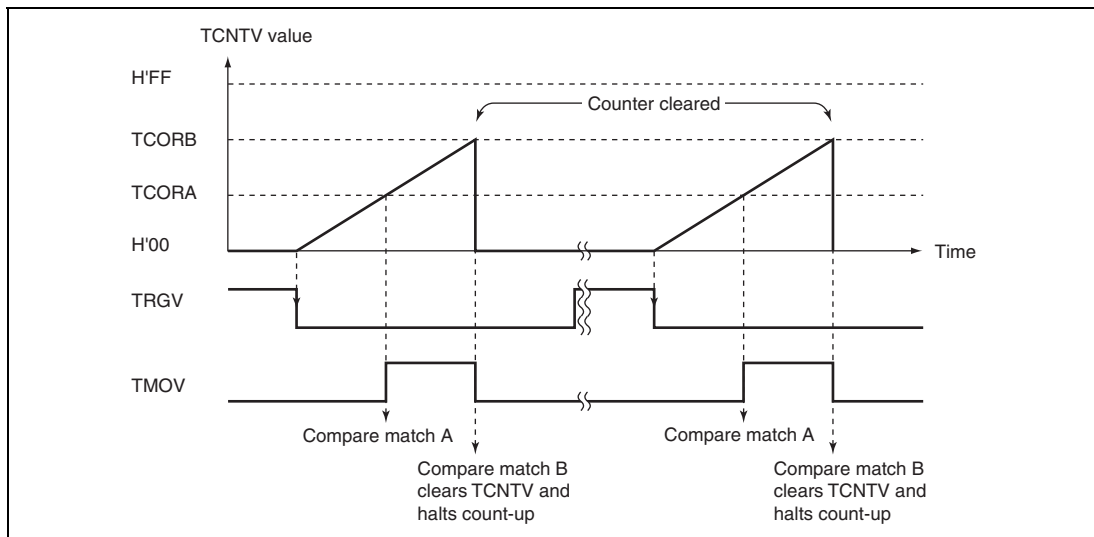

Figure 11.10 Example of Pulse Output Synchronized to TRGV Input

11.6 Usage Notes

The following types of contention or operation can occur in timer V operation.

1. Writing to registers is performed in the T3 state of a TCNTV write cycle. If a TCNTV clear signal is generated in the T3 state of a TCNTV write cycle, as shown in figure 11.11, clearing takes precedence and the write to the counter is not carried out. If counting-up is generated in the T3 state of a TCNTV write cycle, writing takes precedence.
2. If a compare match is generated in the T3 state of a TCORA or TCORB write cycle, the write to TCORA or TCORB takes precedence and the compare match signal is inhibited. Figure 11.12 shows the timing.
3. If compare matches A and B occur simultaneously, any conflict between the output selections for compare match A and compare match B is resolved by the following priority: toggle output > output 1 > output 0.
4. Depending on the timing, TCNTV may be incremented by a switch between different internal clock sources. When TCNTV is internally clocked, an increment pulse is generated from the falling edge of an internal clock signal, that is divided system clock (ϕ). Therefore, as shown in figure 11.3 the switch is from a high clock signal to a low clock signal, the switchover is seen as a falling edge, causing TCNTV to increment. TCNTV can also be incremented by a switch between internal and external clocks.

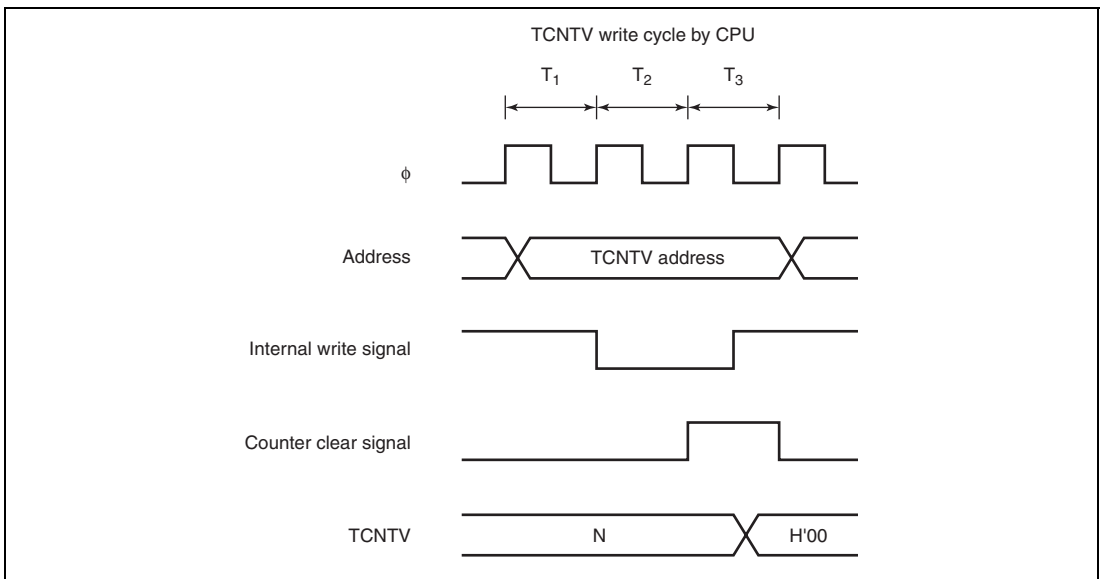

Figure 11.11 Contention between TCNTV Write and Clear

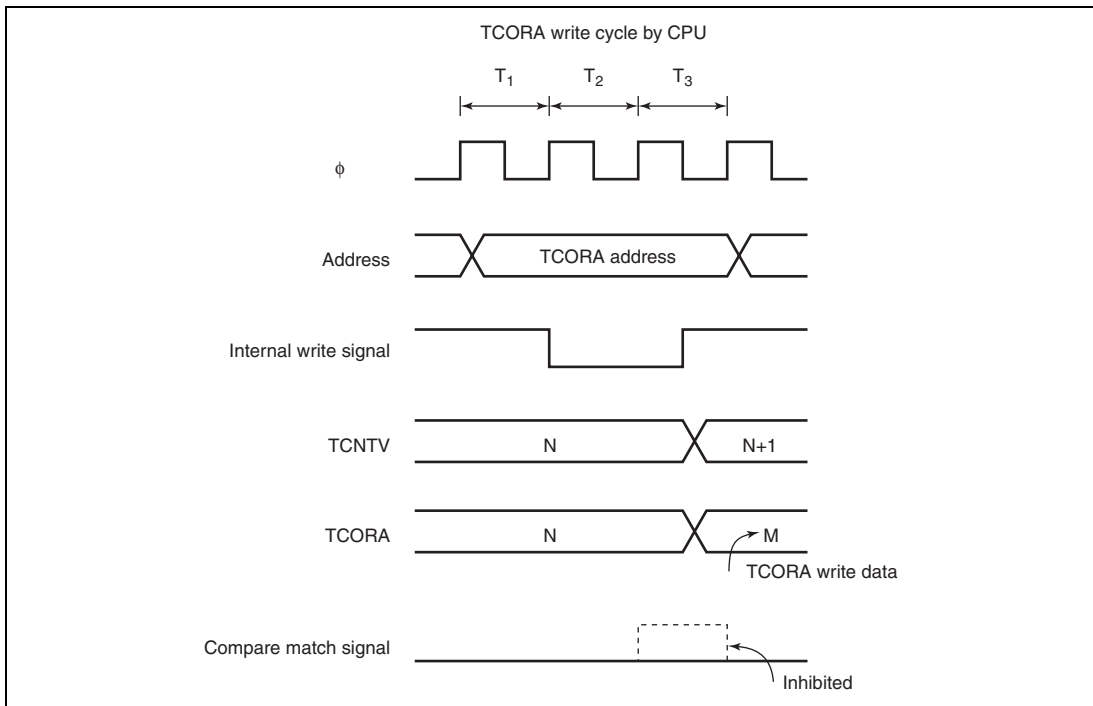

Figure 11.12 Contention between TCORA Write and Compare Match

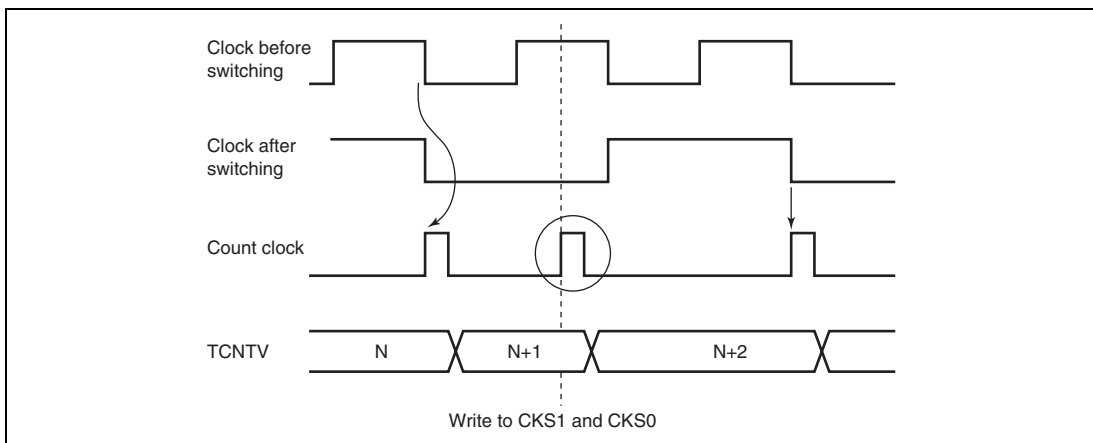

Figure 11.13 Internal Clock Switching and TCNTV Operation

Section 12 Timer W

The timer W has a 16-bit timer having output compare and input capture functions. The timer W can count external events and output pulses with an arbitrary duty cycle by compare match between the timer counter and four general registers. Thus, it can be applied to various systems.

12.1 Features

- Selection of five counter clock sources: four internal clocks (ϕ , $\phi/2$, $\phi/4$, and $\phi/8$) and an external clock (external events can be counted)
- Capability to process up to four pulse outputs or four pulse inputs
- Four general registers:
 - Independently assignable output compare or input capture functions
 - Usable as two pairs of registers; one register of each pair operates as a buffer for the output compare or input capture register
- Four selectable operating modes :
 - Waveform output by compare match
Selection of 0 output, 1 output, or toggle output
 - Input capture function
Rising edge, falling edge, or both edges
 - Counter clearing function
Counters can be cleared by compare match
 - PWM mode
Up to three-phase PWM output can be provided with desired duty ratio.
- Any initial timer output value can be set
- Five interrupt sources
Four compare match/input capture interrupts and an overflow interrupt.

Table 12.1 summarizes the timer W functions, and figure 12.1 shows a block diagram of the timer W.

Table 12.1 Timer W Functions

| Item | Counter | Input/Output Pins | | | |
|--|--|-----------------------------------|-----------------------------------|---|---|
| | | FTIOA | FTIOB | FTIOC | FTIOD |
| Count clock | Internal clocks: ϕ , $\phi/2$, $\phi/4$, $\phi/8$ External clock: FTCl | | | | |
| General registers (output compare/input capture registers) | Period specified in GRA | GRA | GRB | GRC (buffer register for GRA in buffer mode) | GRD (buffer register for GRB in buffer mode) |
| Counter clearing function | GRA compare match | GRA compare match | — | — | — |
| Initial output value setting function | — | Yes | Yes | Yes | Yes |
| Buffer function | — | Yes | Yes | — | — |
| Compare | 0 | — | Yes | Yes | Yes |
| match output | 1 | — | Yes | Yes | Yes |
| | Toggle | — | Yes | Yes | Yes |
| Input capture function | — | Yes | Yes | Yes | Yes |
| PWM mode | — | — | Yes | Yes | Yes |
| Interrupt sources | Overflow | Compare match/input capture | Compare match/input capture | Compare match/input capture | Compare match/input capture |

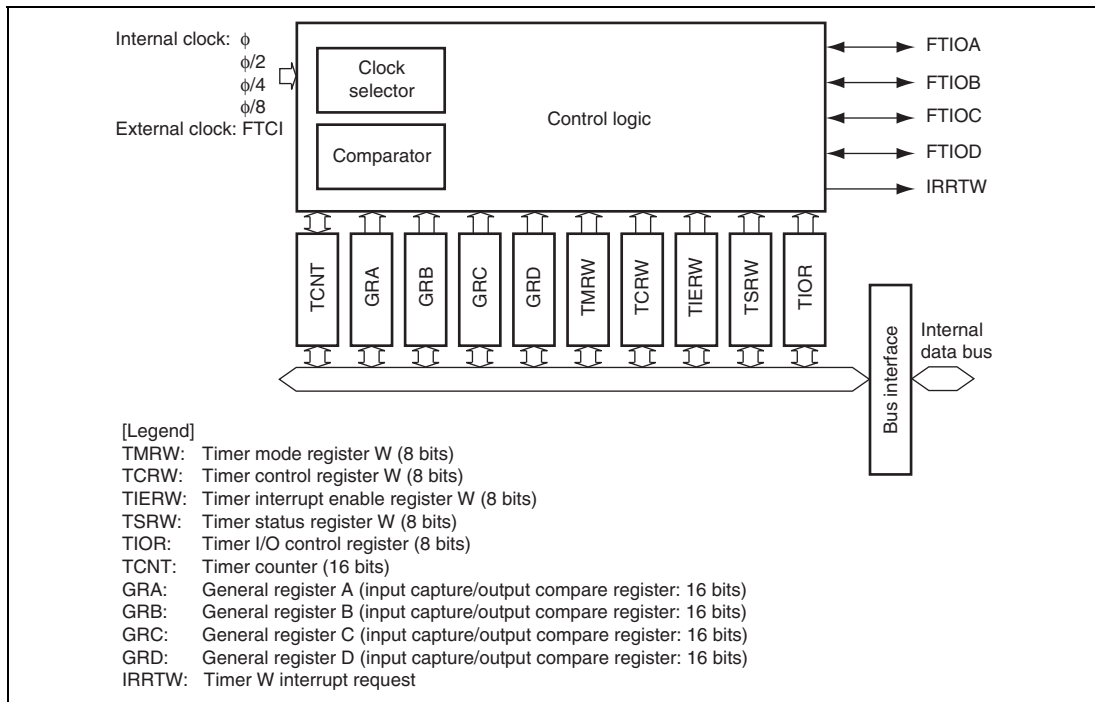

Figure 12.1 Timer W Block Diagram

12.2 Input/Output Pins

Table 12.2 summarizes the timer W pins.

Table 12.2 Pin Configuration

| Name | Abbreviation | Input/Output | Function |
|--------------------------------|--------------|--------------|---|
| External clock input | FTCI | Input | External clock input pin |
| Input capture/output compare A | FTIOA | Input/output | Output pin for GRA output compare or input pin for GRA input capture |
| Input capture/output compare B | FTIOB | Input/output | Output pin for GRB output compare, input pin for GRB input capture, or PWM output pin in PWM mode |
| Input capture/output compare C | FTIOC | Input/output | Output pin for GRC output compare, input pin for GRC input capture, or PWM output pin in PWM mode |
| Input capture/output compare D | FTIOD | Input/output | Output pin for GRD output compare, input pin for GRD input capture, or PWM output pin in PWM mode |

12.3 Register Descriptions

The timer W has the following registers.

- Timer mode register W (TMRW)
- Timer control register W (TCRW)
- Timer interrupt enable register W (TIERW)
- Timer status register W (TSRW)
- Timer I/O control register 0 (TIOR0)
- Timer I/O control register 1 (TIOR1)
- Timer counter (TCNT)
- General register A (GRA)
- General register B (GRB)
- General register C (GRC)
- General register D (GRD)

12.3.1 Timer Mode Register W (TMRW)

TMRW selects the general register functions and the timer output mode.

| Bit | Bit Name | Initial Value | R/W | Description |
|-----|----------|---------------|-----|--|
| 7 | CTS | 0 | R/W | Counter Start The counter operation is halted when this bit is 0, while it can be performed when this bit is 1. |
| 6 | — | 1 | — | Reserved This bit is always read as 1. |
| 5 | BUFEB | 0 | R/W | Buffer Operation B Selects the GRD function. 0: GRD operates as an input capture/output compare register 1: GRD operates as the buffer register for GRB |
| 4 | BUFEA | 0 | R/W | Buffer Operation A Selects the GRC function. 0: GRC operates as an input capture/output compare register 1: GRC operates as the buffer register for GRA |
| 3 | — | 1 | — | Reserved This bit is always read as 1. |
| 2 | PWMD | 0 | R/W | PWM Mode D Selects the output mode of the FTIOD pin. 0: FTIOD operates normally (output compare output) 1: PWM output |
| 1 | PWMC | 0 | R/W | PWM Mode C Selects the output mode of the FTIOC pin. 0: FTIOC operates normally (output compare output) 1: PWM output |
| 0 | PWMB | 0 | R/W | PWM Mode B Selects the output mode of the FTIOB pin. 0: FTIOB operates normally (output compare output) 1: PWM output |

12.3.2 Timer Control Register W (TCRW)

TCRW selects the timer counter clock source, selects a clearing condition, and specifies the timer output levels.

| Bit | Bit Name | Initial Value | R/W | Description |
|-----|----------|---------------|-----|--|
| 7 | CCLR | 0 | R/W | Counter Clear The TCNT value is cleared by compare match A when this bit is 1. When it is 0, TCNT operates as a free-running counter. |
| 6 | CKS2 | 0 | R/W | Clock Select 2 to 0 |
| 5 | CKS1 | 0 | R/W | Select the TCNT clock source. |
| 4 | CKS0 | 0 | R/W | 000: Internal clock: counts on ϕ 001: Internal clock: counts on $\phi/2$ 010: Internal clock: counts on $\phi/4$ 011: Internal clock: counts on $\phi/8$ 1XX: Counts on rising edges of the external event (FTCI) When the internal clock source (ϕ) is selected, subclock sources are counted in subactive and subsleep modes. |
| 3 | TOD | 0 | R/W | Timer Output Level Setting D Sets the output value of the FTIOD pin until the first compare match D is generated. 0: Output value is 0* 1: Output value is 1* |
| 2 | TOC | 0 | R/W | Timer Output Level Setting C Sets the output value of the FTIOC pin until the first compare match C is generated. 0: Output value is 0* 1: Output value is 1* |
| 1 | TOB | 0 | R/W | Timer Output Level Setting B Sets the output value of the FTIOB pin until the first compare match B is generated. 0: Output value is 0* 1: Output value is 1* |

| Bit | Bit Name | Initial Value | R/W | Description |
|-----|----------|---------------|-----|--|
| 0 | TOA | 0 | R/W | Timer Output Level Setting A Sets the output value of the FTIOA pin until the first compare match A is generated. 0: Output value is 0* 1: Output value is 1* |

Legend: X: Don't care.

Note: * The change of the setting is immediately reflected in the output value.

12.3.3 Timer Interrupt Enable Register W (TIERW)

TIERW controls the timer W interrupt request.

| Bit | Bit Name | Initial Value | R/W | Description |
|--------|----------|---------------|-----|--|
| 7 | OVIE | 0 | R/W | Timer Overflow Interrupt Enable When this bit is set to 1, FOVI interrupt requested by OVF flag in TSRW is enabled. |
| 6 to 4 | — | All 1 | — | Reserved These bits are always read as 1. |
| 3 | IMIED | 0 | R/W | Input Capture/Compare Match Interrupt Enable D When this bit is set to 1, IMID interrupt requested by IMFD flag in TSRW is enabled. |
| 2 | IMIEC | 0 | R/W | Input Capture/Compare Match Interrupt Enable C When this bit is set to 1, IMIC interrupt requested by IMFC flag in TSRW is enabled. |
| 1 | IMIEB | 0 | R/W | Input Capture/Compare Match Interrupt Enable B When this bit is set to 1, IMIB interrupt requested by IMFB flag in TSRW is enabled. |
| 0 | IMIEA | 0 | R/W | Input Capture/Compare Match Interrupt Enable A When this bit is set to 1, IMIA interrupt requested by IMFA flag in TSRW is enabled. |

12.3.4 Timer Status Register W (TSRW)

TSRW shows the status of interrupt requests.

| Bit | Bit Name | Initial Value | R/W | Description |
|--------|----------|---------------|-----|---|
| 7 | OVF | 0 | R/W | Timer Overflow Flag [Setting condition] When TCNT overflows from H'FFFF to H'0000 [Clearing condition] Read OVF when OVF = 1, then write 0 in OVF |
| 6 to 4 | — | All 1 | — | Reserved These bits are always read as 1. |
| 3 | IMFD | 0 | R/W | Input Capture/Compare Match Flag D [Setting conditions] <ul style="list-style-type: none"> • TCNT = GRD when GRD functions as an output compare register • The TCNT value is transferred to GRD by an input capture signal when GRD functions as an input capture register [Clearing condition] Read IMFD when IMFD = 1, then write 0 in IMFD |
| 2 | IMFC | 0 | R/W | Input Capture/Compare Match Flag C [Setting conditions] <ul style="list-style-type: none"> • TCNT = GRC when GRC functions as an output compare register • The TCNT value is transferred to GRC by an input capture signal when GRC functions as an input capture register [Clearing condition] Read IMFC when IMFC = 1, then write 0 in IMFC |

| Bit | Bit Name | Initial Value | R/W | Description |
|-----|----------|---------------|-----|---|
| 1 | IMFB | 0 | R/W | Input Capture/Compare Match Flag B [Setting conditions] <ul style="list-style-type: none"> • TCNT = GRB when GRB functions as an output compare register • The TCNT value is transferred to GRB by an input capture signal when GRB functions as an input capture register [Clearing condition] Read IMFB when IMFB = 1, then write 0 in IMFB |
| 0 | IMFA | 0 | R/W | Input Capture/Compare Match Flag A [Setting conditions] <ul style="list-style-type: none"> • TCNT = GRA when GRA functions as an output compare register • The TCNT value is transferred to GRA by an input capture signal when GRA functions as an input capture register [Clearing condition] Read IMFA when IMFA = 1, then write 0 in IMFA |

12.3.5 Timer I/O Control Register 0 (TIOR0)

TIOR0 selects the functions of GRA and GRB, and specifies the functions of the FTIOA and FTIOB pins.

| Bit | Bit Name | Initial Value | R/W | Description |
|-----|----------|---------------|-----|--|
| 7 | — | 1 | — | Reserved This bit is always read as 1. |
| 6 | IOB2 | 0 | R/W | I/O Control B2 Selects the GRB function. 0: GRB functions as an output compare register 1: GRB functions as an input capture register |

| Bit | Bit Name | Initial Value | R/W | Description |
|-----|----------|---------------|-----|---|
| 5 | IOB1 | 0 | R/W | I/O Control B1 and B0 |
| 4 | IOB0 | 0 | R/W | When IOB2 = 0, 00: No output at compare match 01: 0 output to the FTIOB pin at GRB compare match 10: 1 output to the FTIOB pin at GRB compare match 11: Output toggles to the FTIOB pin at GRB compare match When IOB2 = 1, 00: Input capture at rising edge at the FTIOB pin 01: Input capture at falling edge at the FTIOB pin 1X: Input capture at rising and falling edges of the FTIOB pin |
| 3 | — | 1 | — | Reserved This bit is always read as 1. |
| 2 | IOA2 | 0 | R/W | I/O Control A2 Selects the GRA function. 0: GRA functions as an output compare register 1: GRA functions as an input capture register |
| 1 | IOA1 | 0 | R/W | I/O Control A1 and A0 |
| 0 | IOA0 | 0 | R/W | When IOA2 = 0, 00: No output at compare match 01: 0 output to the FTIOA pin at GRA compare match 10: 1 output to the FTIOA pin at GRA compare match 11: Output toggles to the FTIOA pin at GRA compare match When IOA2 = 1, 00: Input capture at rising edge of the FTIOA pin 01: Input capture at falling edge of the FTIOA pin 1X: Input capture at rising and falling edges of the FTIOA pin |

Legend: X: Don't care.

12.3.6 Timer I/O Control Register 1 (TIOR1)

TIOR1 selects the functions of GRC and GRD, and specifies the functions of the FTIOC and FTIOD pins.

| Bit | Bit Name | Initial Value | R/W | Description |
|-----|----------|---------------|-----|---|
| 7 | — | 1 | — | Reserved This bit is always read as 1. |
| 6 | IOD2 | 0 | R/W | I/O Control D2 Selects the GRD function. 0: GRD functions as an output compare register 1: GRD functions as an input capture register |
| 5 | IOD1 | 0 | R/W | I/O Control D1 and D0 |
| 4 | IOD0 | 0 | R/W | When IOD2 = 0, 00: No output at compare match 01: 0 output to the FTIOD pin at GRD compare match 10: 1 output to the FTIOD pin at GRD compare match 11: Output toggles to the FTIOD pin at GRD compare match When IOD2 = 1, 00: Input capture at rising edge at the FTIOD pin 01: Input capture at falling edge at the FTIOD pin 1X: Input capture at rising and falling edges at the FTIOD pin |
| 3 | — | 1 | — | Reserved This bit is always read as 1. |
| 2 | IOC2 | 0 | R/W | I/O Control C2 Selects the GRC function. 0: GRC functions as an output compare register 1: GRC functions as an input capture register |

| Bit | Bit Name | Initial Value | R/W | Description |
|-----|----------|---------------|-----|--|
| 1 | IOC1 | 0 | R/W | I/O Control C1 and C0 |
| 0 | IOC0 | 0 | R/W | When IOC2 = 0, 00: No output at compare match 01: 0 output to the FTIOC pin at GRC compare match 10: 1 output to the FTIOC pin at GRC compare match 11: Output toggles to the FTIOC pin at GRC compare match When IOC2 = 1, 00: Input capture to GRC at rising edge of the FTIOC pin 01: Input capture to GRC at falling edge of the FTIOC pin 1X: Input capture to GRC at rising and falling edges of the FTIOC pin |

Legend: X: Don't care.

12.3.7 Timer Counter (TCNT)

TCNT is a 16-bit readable/writable up-counter. The clock source is selected by bits CKS2 to CKS0 in TCRW. TCNT can be cleared to H'0000 through a compare match with GRA by setting the CCLR in TCRW to 1. When TCNT overflows (changes from H'FFFF to H'0000), the OVF flag in TSRW is set to 1. If OVIE in TIERW is set to 1 at this time, an interrupt request is generated. TCNT must always be read or written in 16-bit units; 8-bit access is not allowed. TCNT is initialized to H'0000 by a reset.

12.3.8 General Registers A to D (GRA to GRD)

Each general register is a 16-bit readable/writable register that can function as either an output-compare register or an input-capture register. The function is selected by settings in TIOR0 and TIOR1.

When a general register is used as an input-compare register, its value is constantly compared with the TCNT value. When the two values match (a compare match), the corresponding flag (IMFA, IMFB, IMFC, or IMFD) in TSRW is set to 1. An interrupt request is generated at this time, when IMIEA, IMIEB, IMIEC, or IMIED is set to 1. Compare match output can be selected in TIOR.

When a general register is used as an input-capture register, an external input-capture signal is detected and the current TCNT value is stored in the general register. The corresponding flag (IMFA, IMFB, IMFC, or IMFD) in TSRW is set to 1. If the corresponding interrupt-enable bit

(IMIEA, IMIEB, IMIEC, or IMIED) in TSRW is set to 1 at this time, an interrupt request is generated. The edge of the input-capture signal is selected in TIOR.

GRC and GRD can be used as buffer registers of GRA and GRB, respectively, by setting BUFEA and BUFEB in TMRW.

For example, when GRA is set as an output-compare register and GRC is set as the buffer register for GRA, the value in the buffer register GRC is sent to GRA whenever compare match A is generated.

When GRA is set as an input-capture register and GRC is set as the buffer register for GRA, the value in TCNT is transferred to GRA and the value in the buffer register GRC is transferred to GRA whenever an input capture is generated.

GRA to GRD must be written or read in 16-bit units; 8-bit access is not allowed. GRA to GRD are initialized to H'FFFF by a reset.

12.4 Operation

The timer W has the following operating modes.

- Normal Operation
- PWM Operation

12.4.1 Normal Operation

TCNT performs free-running or periodic counting operations. After a reset, TCNT is set as a free-running counter. When the CTS bit in TMRW is set to 1, TCNT starts incrementing the count. When the count overflows from H'FFFF to H'0000, the OVF flag in TSRW is set to 1. If the OVIE in TIERW is set to 1, an interrupt request is generated. Figure 12.2 shows free-running counting.

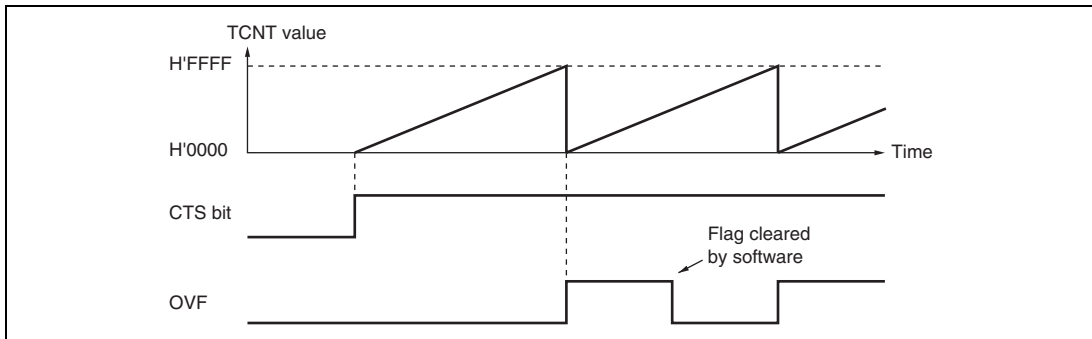

Figure 12.2 Free-Running Counter Operation

Periodic counting operation can be performed when GRA is set as an output compare register and bit CCLR in TCRW is set to 1. When the count matches GRA, TCNT is cleared to H'0000, the IMFA flag in TSRW is set to 1. If the corresponding IMIEA bit in TIERW is set to 1, an interrupt request is generated. TCNT continues counting from H'0000. Figure 12.3 shows periodic counting.

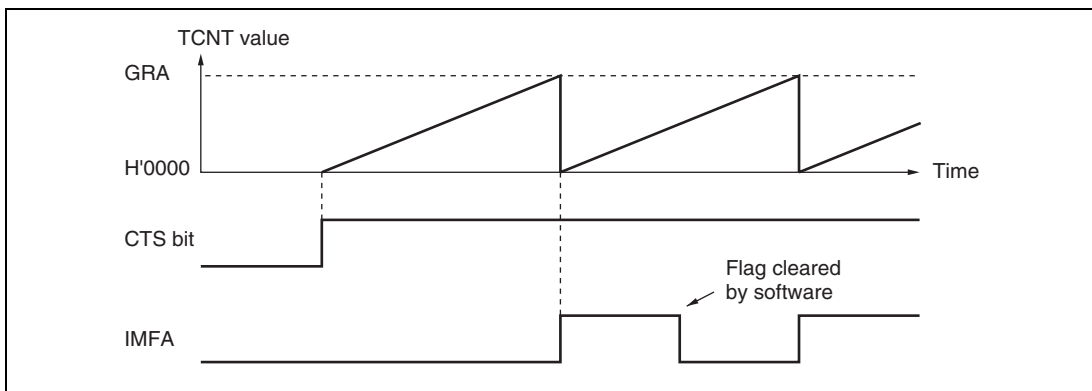

Figure 12.3 Periodic Counter Operation

By setting a general register as an output compare register, compare match A, B, C, or D can cause the output at the FTIOA, FTIOB, FTIOC, or FTIOD pin to output 0, output 1, or toggle. Figure 12.4 shows an example of 0 and 1 output when TCNT operates as a free-running counter, 1 output is selected for compare match A, and 0 output is selected for compare match B. When signal is already at the selected output level, the signal level does not change at compare match.

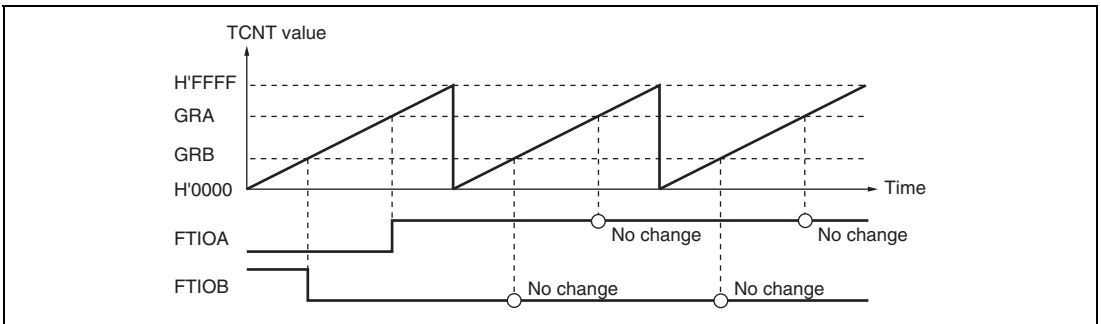

Figure 12.4 0 and 1 Output Example (TOA = 0, TOB = 1)

Figure 12.5 shows an example of toggle output when TCNT operates as a free-running counter, and toggle output is selected for both compare match A and B.

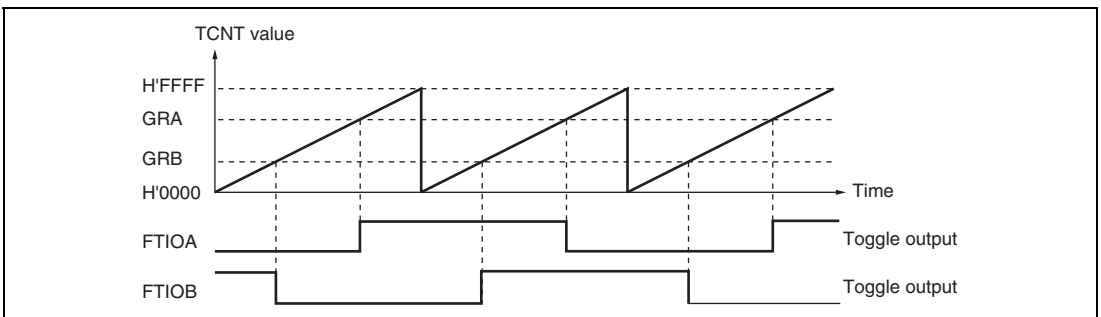

Figure 12.5 Toggle Output Example (TOA = 0, TOB = 1)

Figure 12.6 shows another example of toggle output when TCNT operates as a periodic counter, cleared by compare match A. Toggle output is selected for both compare match A and B.

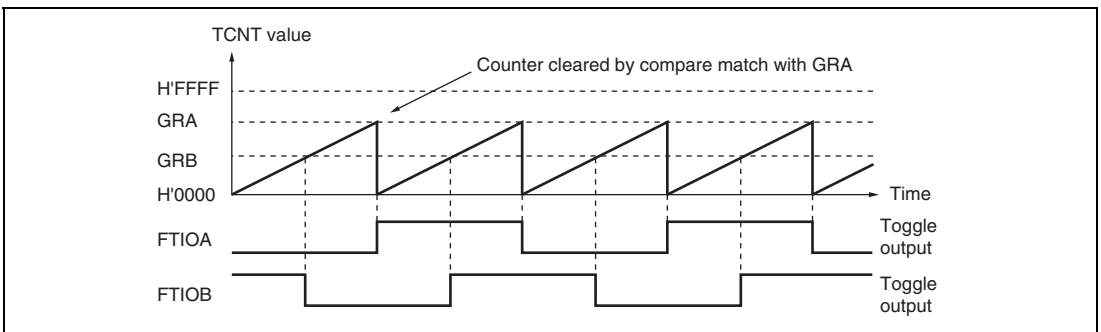

Figure 12.6 Toggle Output Example (TOA = 0, TOB = 1)

The TCNT value can be captured into a general register (GRA, GRB, GRC, or GRD) when a signal level changes at an input-capture pin (FTIOA, FTIOB, FTIOC, or FTIOD). Capture can take place on the rising edge, falling edge, or both edges. By using the input-capture function, the pulse width and periods can be measured. Figure 12.7 shows an example of input capture when both edges of FTIOA and the falling edge of FTIOB are selected as capture edges. TCNT operates as a free-running counter.

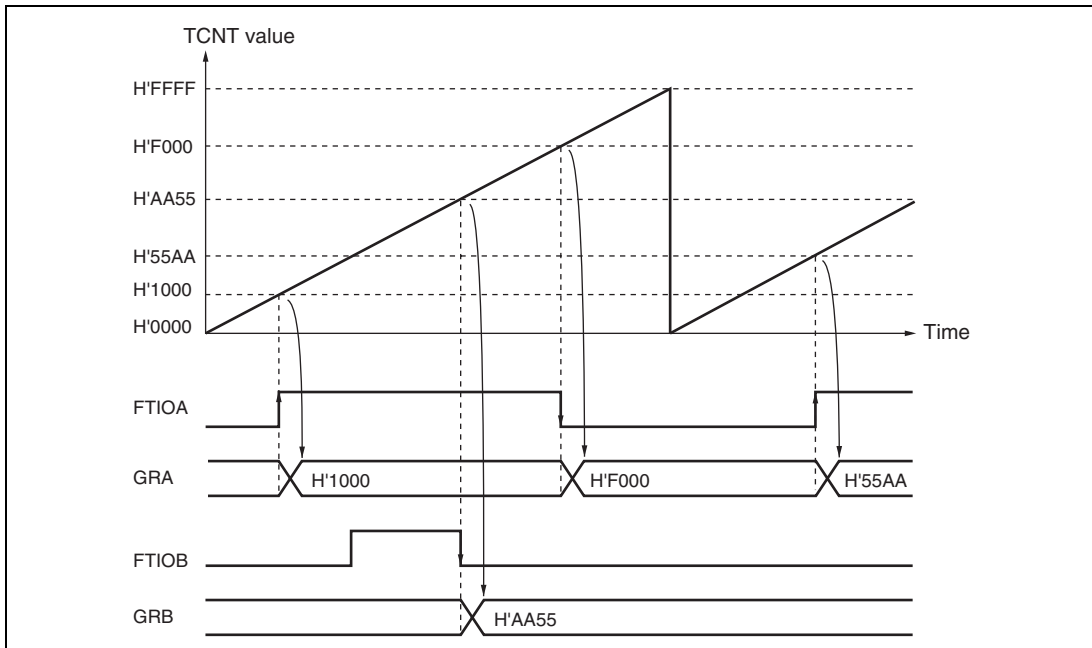

Figure 12.7 Input Capture Operating Example

Figure 12.8 shows an example of buffer operation when the GRA is set as an input-capture register and GRC is set as the buffer register for GRA. TCNT operates as a free-running counter, and FTIOA captures both rising and falling edge of the input signal. Due to the buffer operation, the GRA value is transferred to GRC by input-capture A and the TCNT value is stored in GRA.

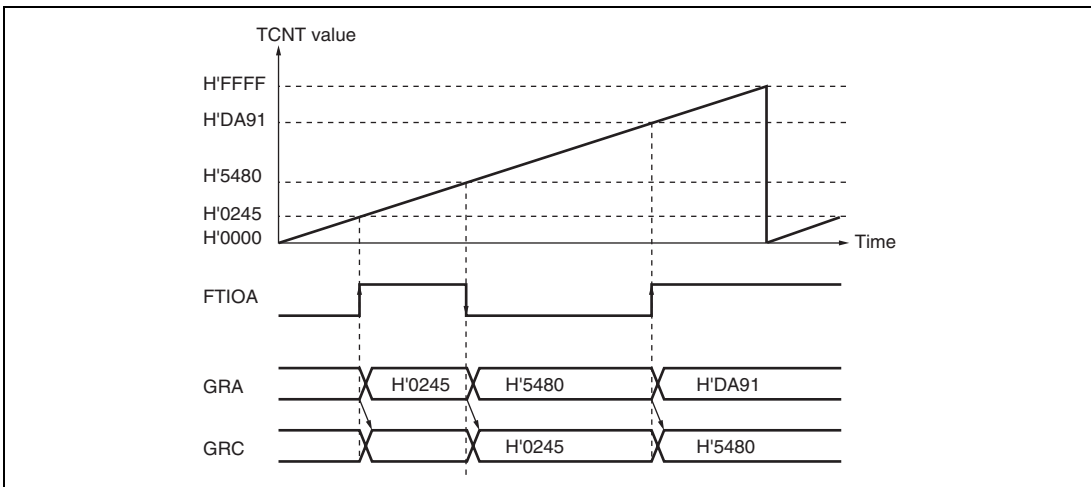

Figure 12.8 Buffer Operation Example (Input Capture)

12.4.2 PWM Operation

In PWM mode, PWM waveforms are generated by using GRA as the period register and GRB, GRC, and GRD as duty registers. PWM waveforms are output from the FTIOB, FTIOC, and FTIOD pins. Up to three-phase PWM waveforms can be output. In PWM mode, a general register functions as an output compare register automatically. The output level of each pin depends on the corresponding timer output level set bit (TOB, TOC, and TOD) in TCRW. When TOB is 1, the FTIOB output goes to 1 at compare match A and to 0 at compare match B. When TOB is 0, the FTIOB output goes to 0 at compare match A and to 1 at compare match B. Thus the compare match output level settings in TIOR0 and TIOR1 are ignored for the output pin set to PWM mode. If the same value is set in the cycle register and the duty register, the output does not change when a compare match occurs.

Figure 12.9 shows an example of operation in PWM mode. The output signals go to 1 and TCNT is cleared at compare match A, and the output signals go to 0 at compare match B, C, and D (TOB, TOC, and TOD = 1: initial output values are set to 1).

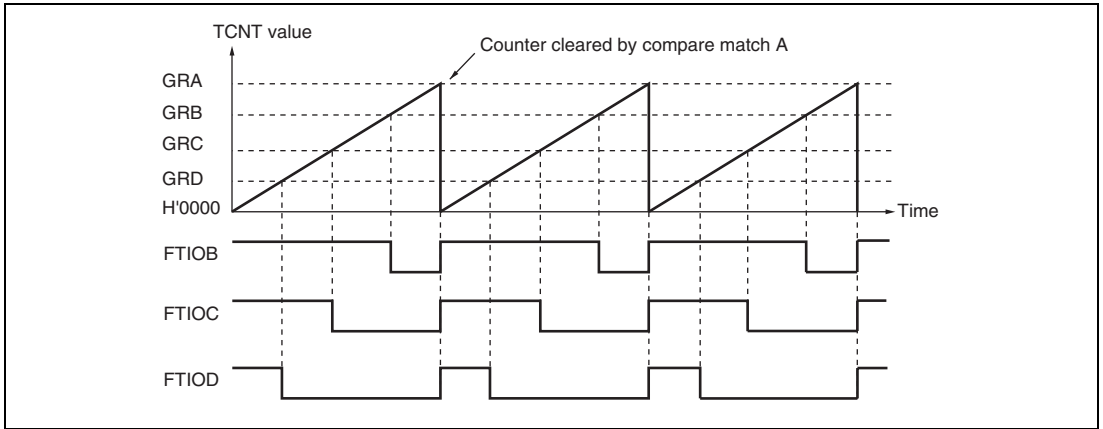

Figure 12.9 PWM Mode Example (1)

Figure 12.10 shows another example of operation in PWM mode. The output signals go to 0 and TCNT is cleared at compare match A, and the output signals go to 1 at compare match B, C, and D (TOB, TOC, and TOD = 0: initial output values are set to 1).

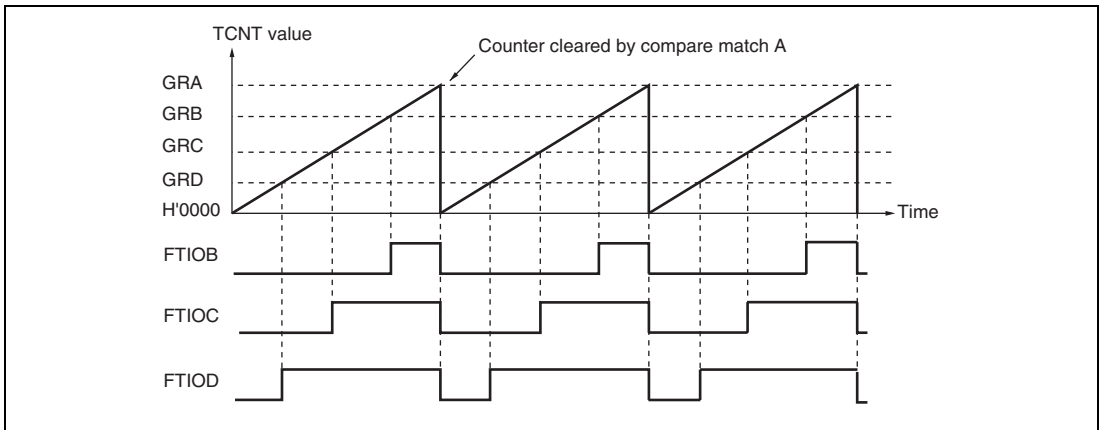

Figure 12.10 PWM Mode Example (2)

Figure 12.11 shows an example of buffer operation when the FTIOB pin is set to PWM mode and GRD is set as the buffer register for GRB. TCNT is cleared by compare match A, and FTIOB outputs 1 at compare match B and 0 at compare match A.

Due to the buffer operation, the FTIOB output level changes and the value of buffer register GRD is transferred to GRB whenever compare match B occurs. This procedure is repeated every time compare match B occurs.

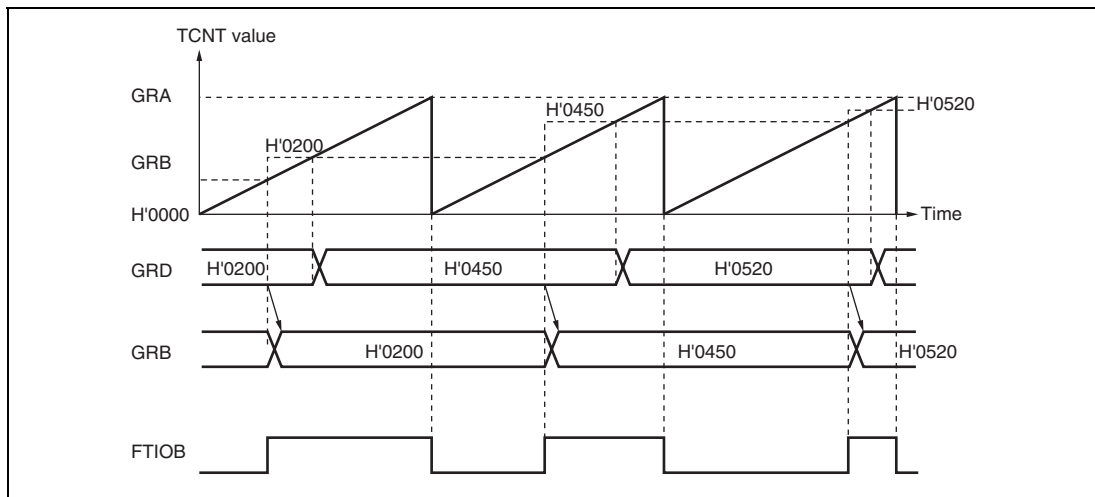

Figure 12.11 Buffer Operation Example (Output Compare)

Figures 12.12 and 12.13 show examples of the output of PWM waveforms with duty cycles of 0% and 100%.

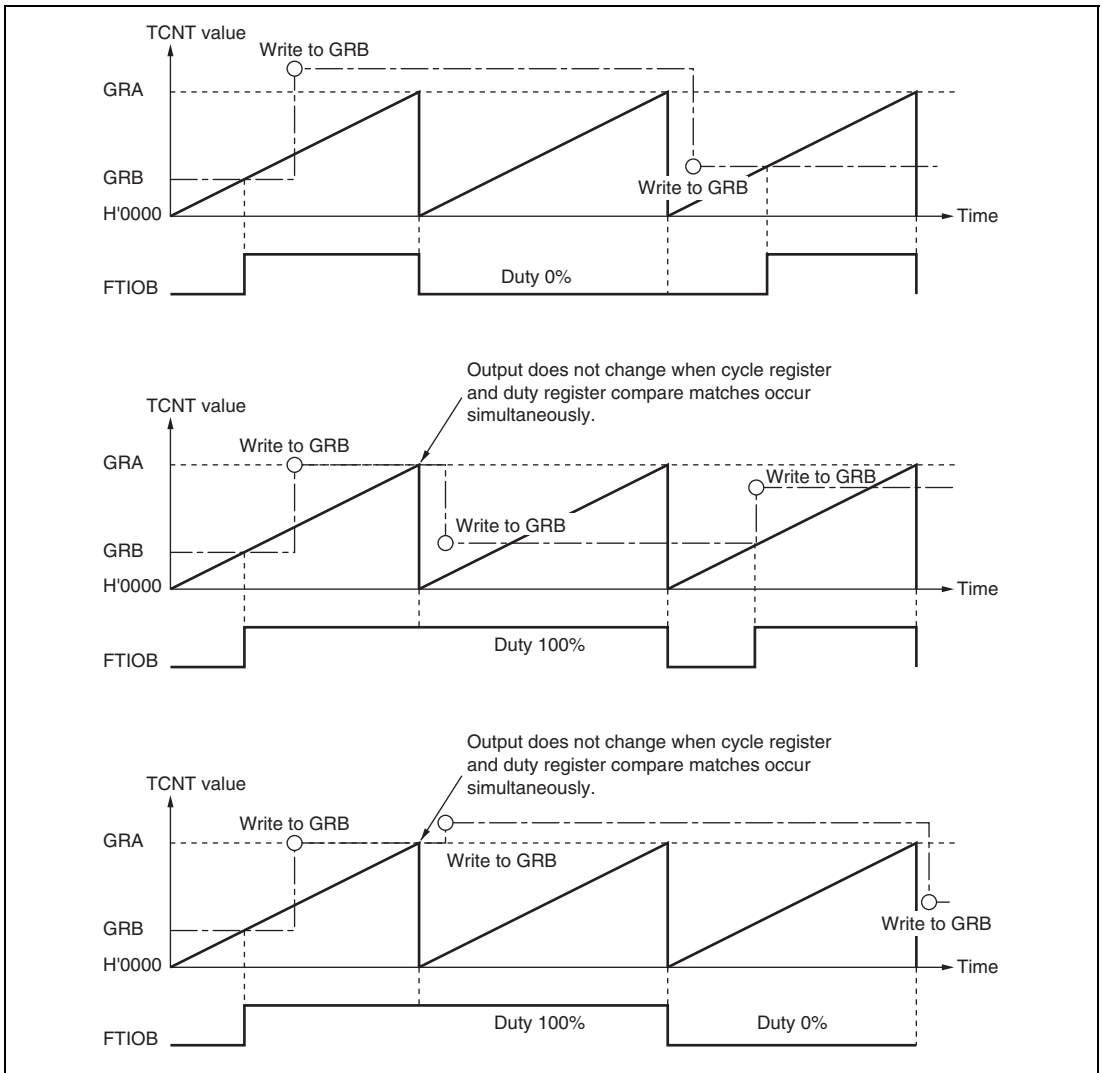

Figure 12.12 PWM Mode Example
 (TOB, TOC, and TOD = 0: initial output values are set to 0)

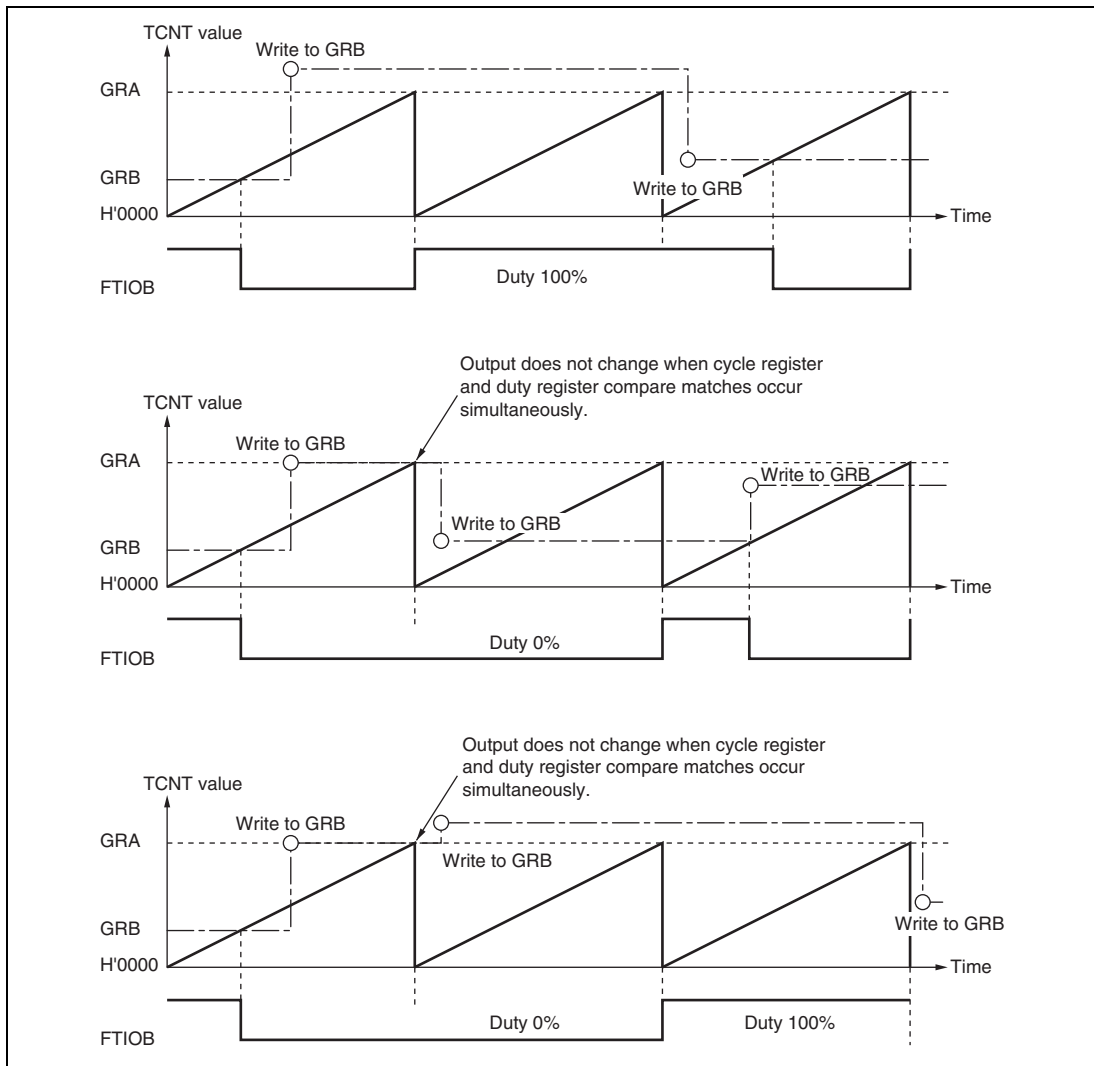

Figure 12.13 PWM Mode Example
(TOB, TOC, and TOD = 1: initial output values are set to 1)

12.5 Operation Timing

12.5.1 TCNT Count Timing

Figure 12.14 shows the TCNT count timing when the internal clock source is selected. Figure 12.15 shows the timing when the external clock source is selected. The pulse width of the external clock signal must be at least two system clock (ϕ) cycles; shorter pulses will not be counted correctly.

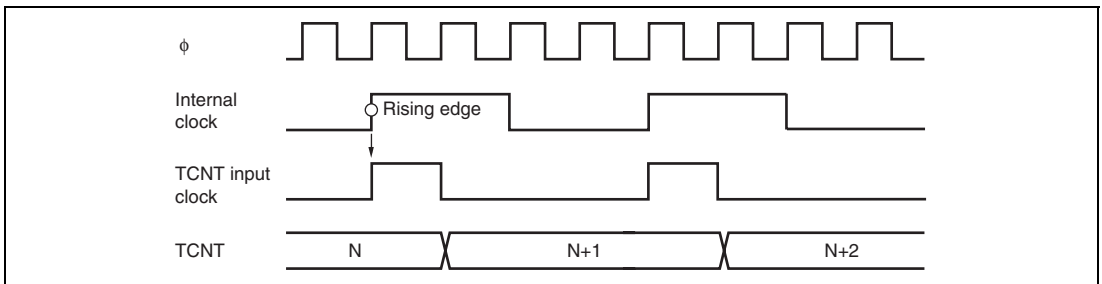

Figure 12.14 Count Timing for Internal Clock Source

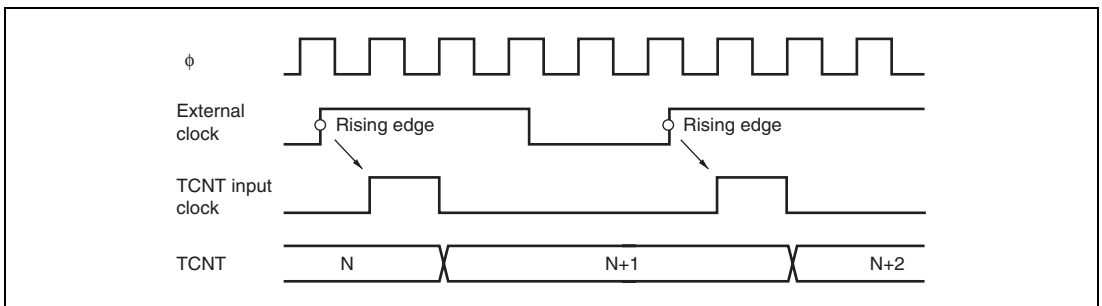

Figure 12.15 Count Timing for External Clock Source

12.5.2 Output Compare Output Timing

The compare match signal is generated in the last state in which TCNT and GR match (when TCNT changes from the matching value to the next value). When the compare match signal is generated, the output value selected in TIOR is output at the compare match output pin (FTIOA, FTIOB, FTIOC, or FTIOD).

When TCNT matches GR, the compare match signal is generated only after the next counter clock pulse is input.

Figure 12.16 shows the output compare timing.

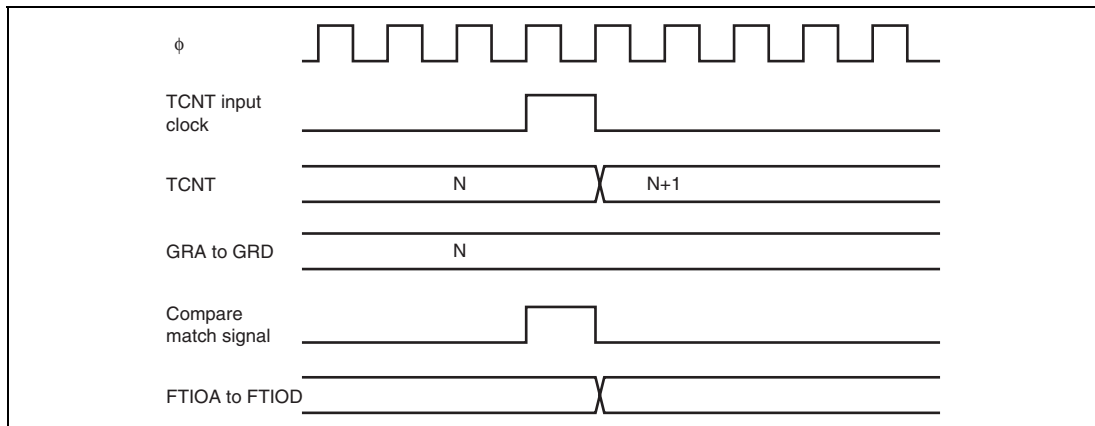

Figure 12.16 Output Compare Output Timing

12.5.3 Input Capture Timing

Input capture on the rising edge, falling edge, or both edges can be selected through settings in TIOR0 and TIOR1. Figure 12.17 shows the timing when the falling edge is selected. The pulse width of the input capture signal must be at least two system clock (ϕ) cycles; shorter pulses will not be detected correctly.

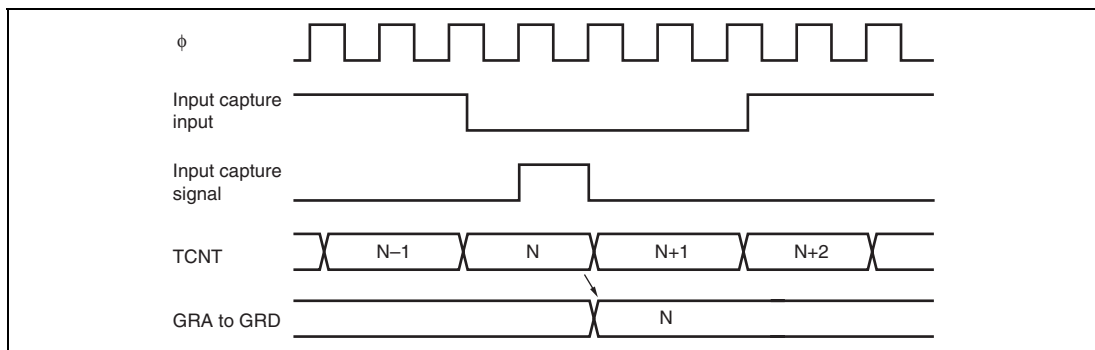

Figure 12.17 Input Capture Input Signal Timing

12.5.4 Timing of Counter Clearing by Compare Match

Figure 12.18 shows the timing when the counter is cleared by compare match A. When the GRA value is N, the counter counts from 0 to N, and its cycle is N + 1.

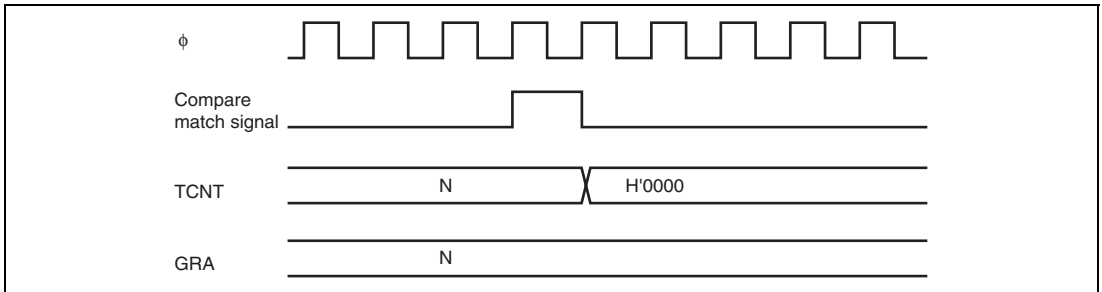

Figure 12.18 Timing of Counter Clearing by Compare Match

12.5.5 Buffer Operation Timing

Figures 12.19 and 12.20 show the buffer operation timing.

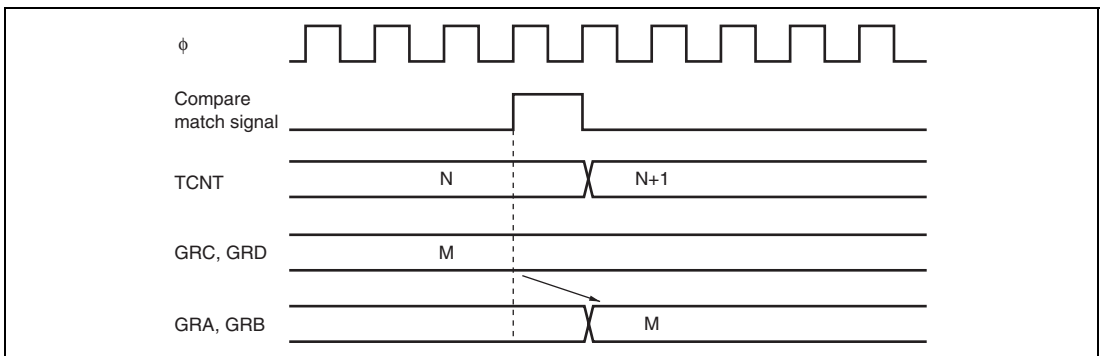

Figure 12.19 Buffer Operation Timing (Compare Match)

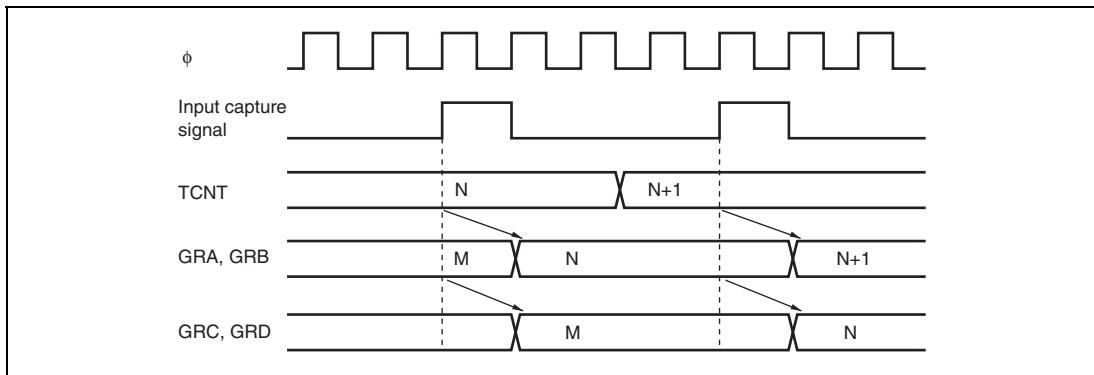

Figure 12.20 Buffer Operation Timing (Input Capture)

12.5.6 Timing of IMFA to IMFD Flag Setting at Compare Match

If a general register (GRA, GRB, GRC, or GRD) is used as an output compare register, the corresponding IMFA, IMFB, IMFC, or IMFD flag is set to 1 when TCNT matches the general register.

The compare match signal is generated in the last state in which the values match (when TCNT is updated from the matching count to the next count). Therefore, when TCNT matches a general register, the compare match signal is generated only after the next TCNT clock pulse is input.

Figure 12.21 shows the timing of the IMFA to IMFD flag setting at compare match.

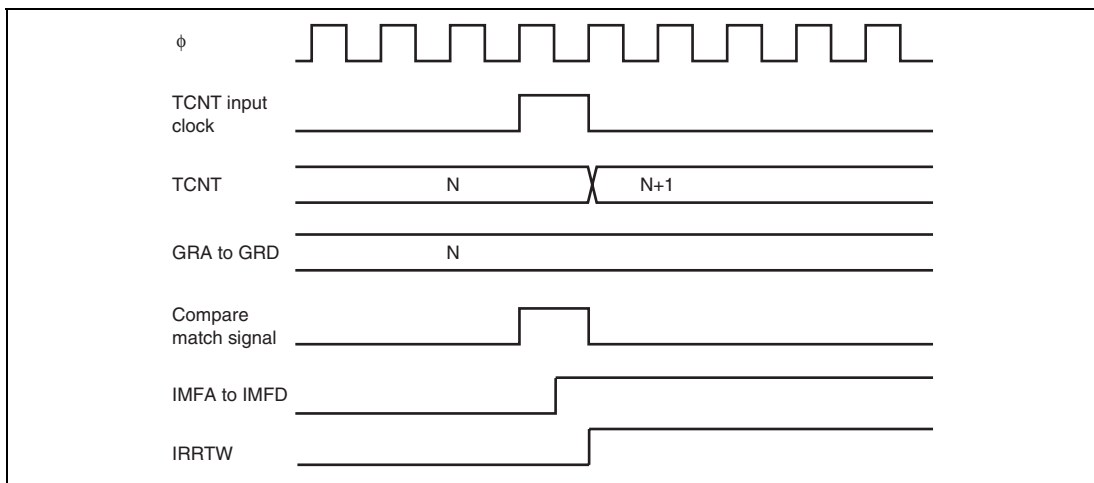

Figure 12.21 Timing of IMFA to IMFD Flag Setting at Compare Match

12.5.7 Timing of IMFA to IMFD Setting at Input Capture

If a general register (GRA, GRB, GRC, or GRD) is used as an input capture register, the corresponding IMFA, IMFB, IMFC, or IMFD flag is set to 1 when an input capture occurs. Figure 12.22 shows the timing of the IMFA to IMFD flag setting at input capture.

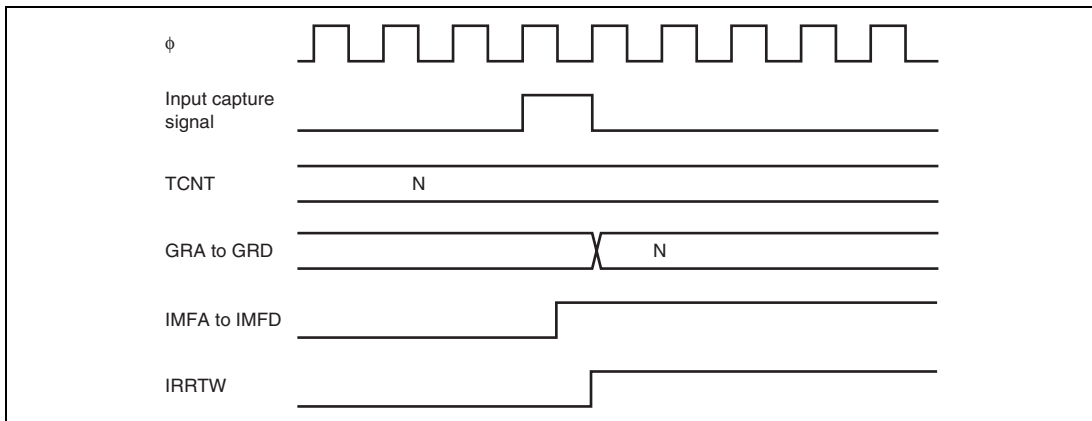

Figure 12.22 Timing of IMFA to IMFD Flag Setting at Input Capture

12.5.8 Timing of Status Flag Clearing

When the CPU reads a status flag while it is set to 1, then writes 0 in the status flag, the status flag is cleared. Figure 12.23 shows the status flag clearing timing.

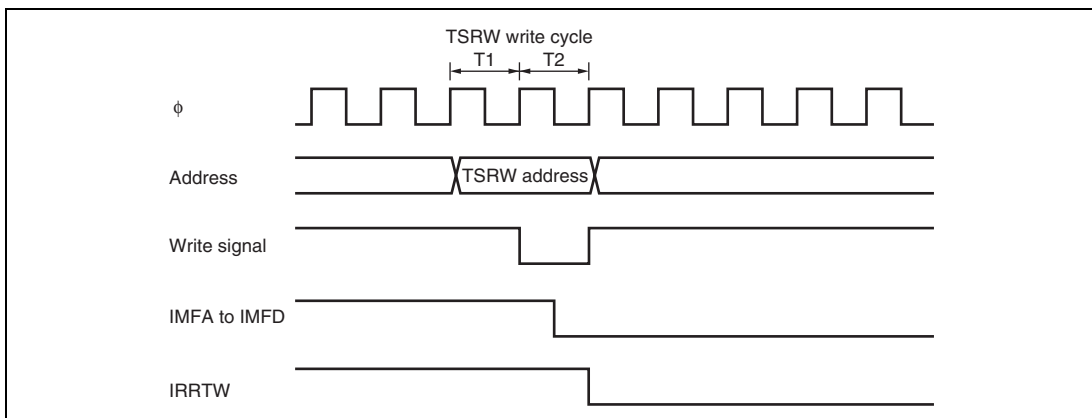

Figure 12.23 Timing of Status Flag Clearing by CPU

12.6 Usage Notes

The following types of contention or operation can occur in timer W operation.

1. The pulse width of the input clock signal and the input capture signal must be at least two system clock (ϕ) cycles; shorter pulses will not be detected correctly.
2. Writing to registers is performed in the T2 state of a TCNT write cycle.
If counter clear signal occurs in the T2 state of a TCNT write cycle, clearing of the counter takes priority and the write is not performed, as shown in figure 12.24. If counting-up is generated in the TCNT write cycle to contend with the TCNT counting-up, writing takes precedence.
3. Depending on the timing, TCNT may be incremented by a switch between different internal clock sources. When TCNT is internally clocked, an increment pulse is generated from the rising edge of an internal clock signal, that is divided system clock (ϕ). Therefore, as shown in figure 12.25 the switch is from a low clock signal to a high clock signal, the switchover is seen as a rising edge, causing TCNT to increment.
4. If timer W enters module standby mode while an interrupt request is generated, the interrupt request cannot be cleared. Before entering module standby mode, disable interrupt requests.

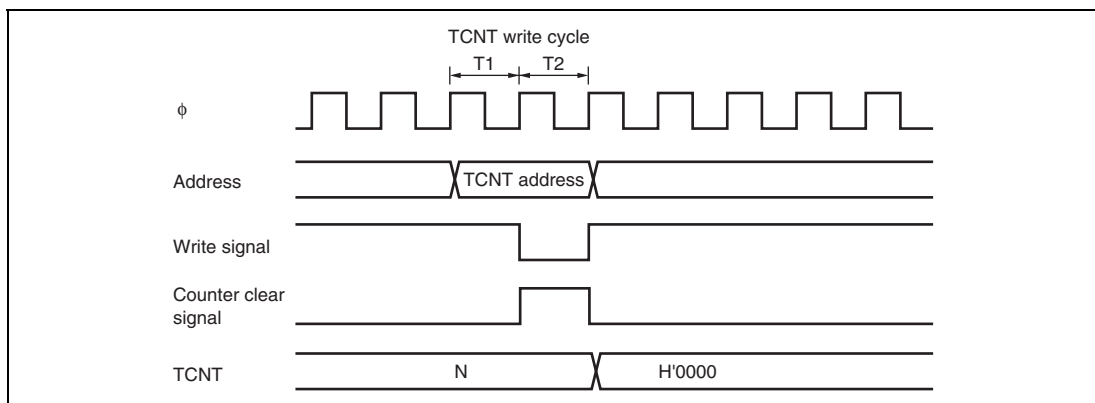

Figure 12.24 Contention between TCNT Write and Clear

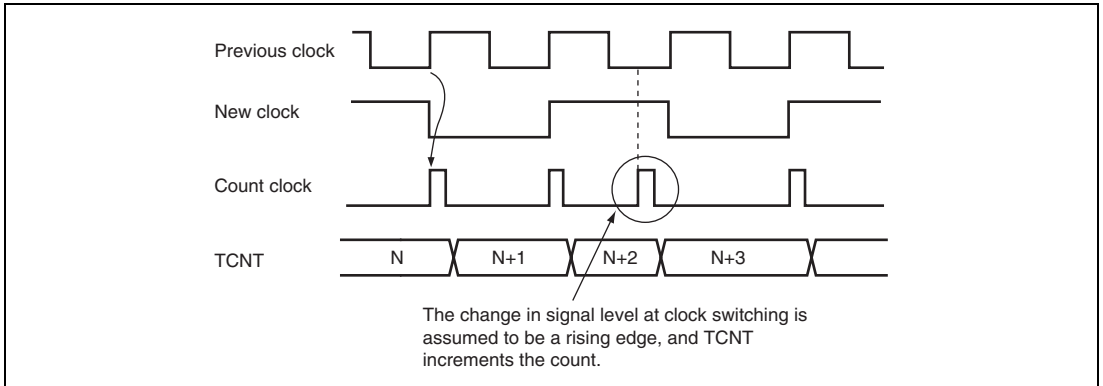

Figure 12.25 Internal Clock Switching and TCNT Operation

5. The TOA to TOD bits in TCRW decide the value of the FTIO pin, which is output until the first compare match occurs. Once a compare match occurs and this compare match changes the values of FTIOA to FTIOD output, the values of the FTIOA to FTIOD pin output and the values read from the TOA to TOD bits may differ. Moreover, when the writing to TCRW and the generation of the compare match A to D occur at the same timing, the writing to TCRW has the priority. Thus, output change due to the compare match is not reflected to the FTIOA to FTIOD pins. Therefore, when bit manipulation instruction is used to write to TCRW, the values of the FTIOA to FTIOD pin output may result in an unexpected result. When TCRW is to be written to while compare match is operating, stop the counter once before accessing to TCRW, read the port 8 state to reflect the values of FTIOA to FTIOD output, to TOA to TOD, and then restart the counter. Figure 12.26 shows an example when the compare match and the bit manipulation instruction to TCRW occur at the same timing.

TCRW has been set to H'06. Compare match B and compare match C are used. The FTIOB pin is in the 1 output state, and is set to the toggle output or the 0 output by compare match B. When BCLR#2, @TCRW is executed to clear the TOC bit (the FTIOB signal is low) and compare match B occurs at the same timing as shown below, the H'02 writing to TCRW has priority and compare match B does not drive the FTIOB signal low; the FTIOB signal remains high.

| Bit | 7 | 6 | 5 | 4 | 3 | 2 | 1 | 0 |
|-----------|------|------|------|------|-----|-----|-----|-----|
| TCRW | CCLR | CKS2 | CKS1 | CKS0 | TOD | TOC | TOB | TOA |
| Set value | 0 | 0 | 0 | 0 | 0 | 1 | 1 | 0 |

BCLR#2, @TCRW
 (1) TCRW read operation: Read H'06
 (2) Modify operation: Modify H'06 to H'02
 (3) Write operation to TCRW: Write H'02

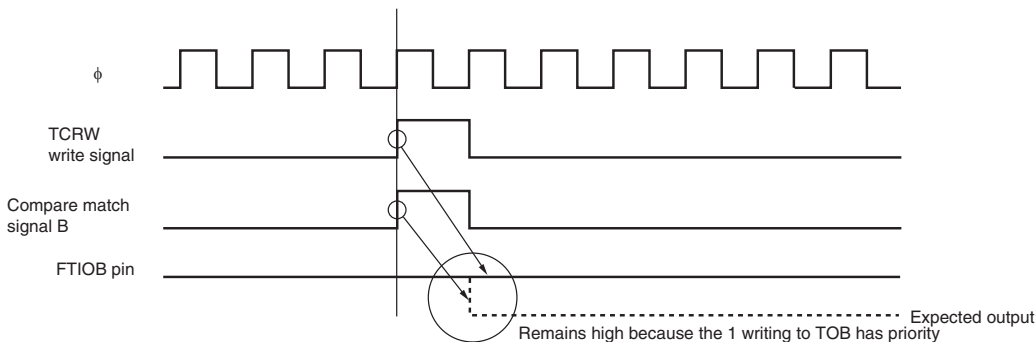

Figure 12.26 When Compare Match and Bit Manipulation Instruction to TCRW Occur at the Same Timing

Section 13 Watchdog Timer

The watchdog timer is an 8-bit timer that can generate an internal reset signal for this LSI if a system crash prevents the CPU from writing to the timer counter, thus allowing it to overflow.

The block diagram of the watchdog timer is shown in figure 13.1.

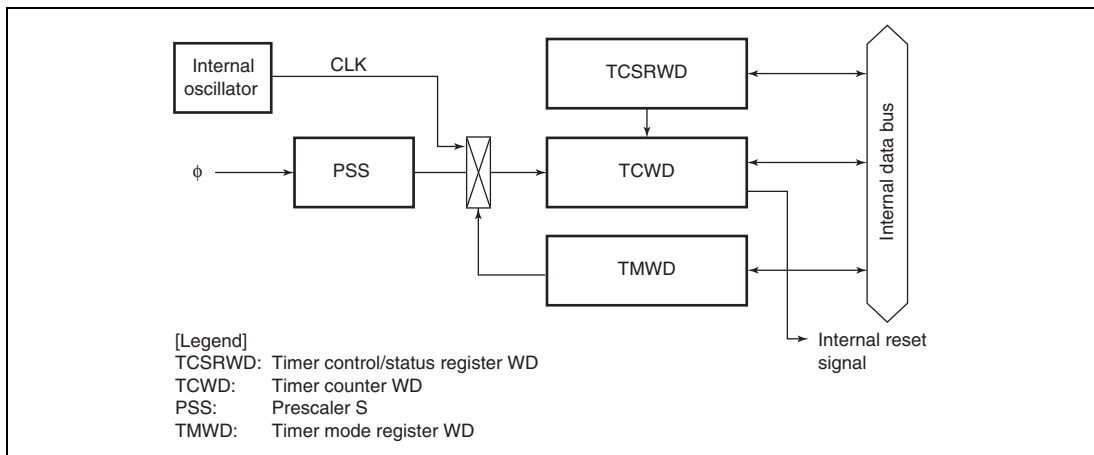

Figure 13.1 Block Diagram of Watchdog Timer

13.1 Features

- Selectable from nine counter input clocks.

Eight clock sources ($\phi/64$, $\phi/128$, $\phi/256$, $\phi/512$, $\phi/1024$, $\phi/2048$, $\phi/4096$, and $\phi/8192$) or the internal oscillator can be selected as the timer-counter clock. When the internal oscillator is selected, it can operate as the watchdog timer in any operating mode.

- Reset signal generated on counter overflow

An overflow period of 1 to 256 times the selected clock can be set.

13.2 Register Descriptions

The watchdog timer has the following registers.

- Timer control/status register WD (TCSRWD)
- Timer counter WD (TCWD)
- Timer mode register WD (TMWD)

13.2.1 Timer Control/Status Register WD (TCSRWD)

TCSRWD performs the TCSRWD and TCWD write control. TCSRWD also controls the watchdog timer operation and indicates the operating state. TCSRWD must be rewritten by using the MOV instruction. The bit manipulation instruction cannot be used to change the setting value.

| Bit | Bit Name | Initial Value | R/W | Description |
|-----|----------|---------------|-----|--|
| 7 | B6WI | 1 | R/W | Bit 6 Write Inhibit The TCWE bit can be written only when the write value of the B6WI bit is 0. This bit is always read as 1. |
| 6 | TCWE | 0 | R/W | Timer Counter WD Write Enable TCWD can be written when the TCWE bit is set to 1. When writing data to this bit, the value for bit 7 must be 0. |
| 5 | B4WI | 1 | R/W | Bit 4 Write Inhibit The TCSRWE bit can be written only when the write value of the B4WI bit is 0. This bit is always read as 1. |
| 4 | TCSRWE | 0 | R/W | Timer Control/Status Register WD Write Enable The WDON and WRST bits can be written when the TCSRWE bit is set to 1. When writing data to this bit, the value for bit 5 must be 0. |
| 3 | B2WI | 1 | R/W | Bit 2 Write Inhibit This bit can be written to the WDON bit only when the write value of the B2WI bit is 0. This bit is always read as 1. |

| Bit | Bit Name | Initial Value | R/W | Description |
|-----|----------|---------------|-----|--|
| 2 | WDON | 0 | R/W | <p>Watchdog Timer On</p> <p>TCWD starts counting up when WDON is set to 1 and halts when WDON is cleared to 0.</p> <p>[Setting condition]</p> <p>When 1 is written to the WDON bit while writing 0 to the B2WI bit when the TCSRWE bit=1</p> <p>[Clearing conditions]</p> <ul style="list-style-type: none"> • Reset by $\overline{\text{RES}}$ pin • When 0 is written to the WDON bit while writing 0 to the B2WI when the TCSRWE bit=1 |
| 1 | BOWI | 1 | R/W | <p>Bit 0 Write Inhibit</p> <p>This bit can be written to the WRST bit only when the write value of the BOWI bit is 0. This bit is always read as 1.</p> |
| 0 | WRST | 0 | R/W | <p>Watchdog Timer Reset</p> <p>[Setting condition]</p> <p>When TCWD overflows and an internal reset signal is generated</p> <p>[Clearing conditions]</p> <ul style="list-style-type: none"> • Reset by $\overline{\text{RES}}$ pin • When 0 is written to the WRST bit while writing 0 to the BOWI bit when the TCSRWE bit=1 |

13.2.2 Timer Counter WD (TCWD)

TCWD is an 8-bit readable/writable up-counter. When TCWD overflows from H'FF to H'00, the internal reset signal is generated and the WRST bit in TCSRWD is set to 1. TCWD is initialized to H'00.

13.2.3 Timer Mode Register WD (TMWD)

TMWD selects the input clock.

| Bit | Bit Name | Initial Value | R/W | Description |
|--------|----------|---------------|-----|--|
| 7 to 4 | — | All 1 | — | Reserved These bits are always read as 1. |
| 3 | CKS3 | 1 | R/W | Clock Select 3 to 0 |
| 2 | CKS2 | 1 | R/W | Select the clock to be input to TCWD. |
| 1 | CKS1 | 1 | R/W | 1000: Internal clock: counts on $\phi/64$ |
| 0 | CKS0 | 1 | R/W | 1001: Internal clock: counts on $\phi/128$ 1010: Internal clock: counts on $\phi/256$ 1011: Internal clock: counts on $\phi/512$ 1100: Internal clock: counts on $\phi/1024$ 1101: Internal clock: counts on $\phi/2048$ 1110: Internal clock: counts on $\phi/4096$ 1111: Internal clock: counts on $\phi 8192$ 0XXX: Internal oscillator For the internal oscillator overflow periods, see section 21, Electrical Characteristics. |

Legend: X: Don't care.

13.3 Operation

The watchdog timer is provided with an 8-bit counter. If 1 is written to WDON while writing 0 to B2WI when the TCSRWE bit in TCSRWD is set to 1, TCWD begins counting up. (To operate the watchdog timer, two write accesses to TCSRWD are required.) When a clock pulse is input after the TCWD count value has reached H'FF, the watchdog timer overflows and an internal reset signal is generated. The internal reset signal is output for a period of $256 \phi_{osc}$ clock cycles. TCWD is a writable counter, and when a value is set in TCWD, the count-up starts from that value. An overflow period in the range of 1 to 256 input clock cycles can therefore be set, according to the TCWD set value.

Figure 13.2 shows an example of watchdog timer operation.

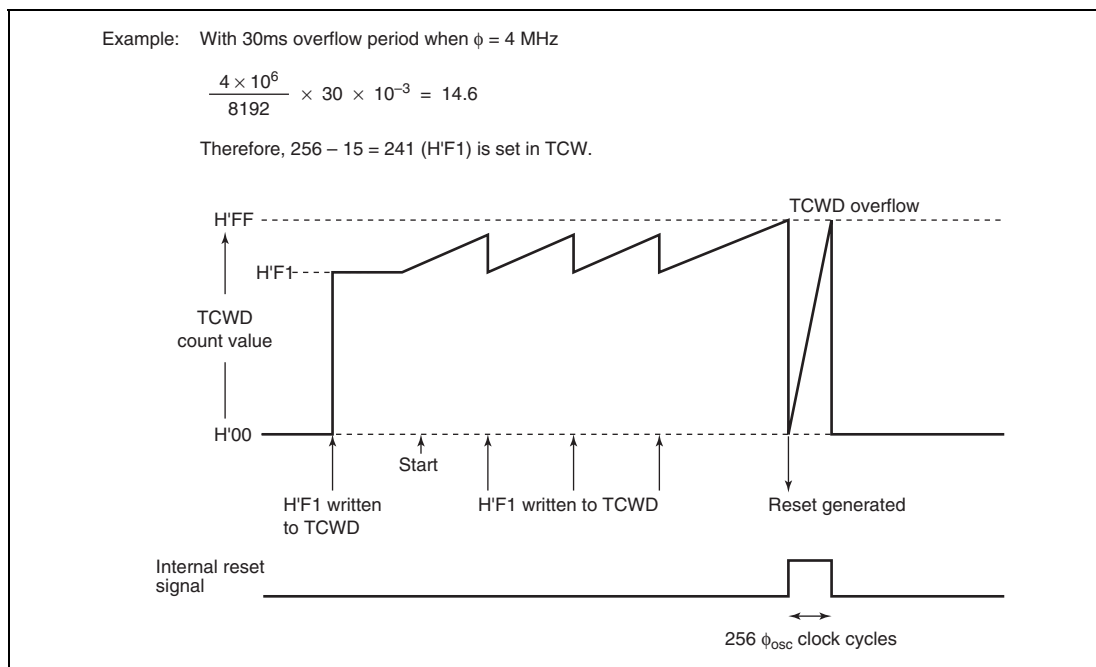

Figure 13.2 Watchdog Timer Operation Example

Section 14 Serial Communication Interface 3 (SCI3)

Serial Communication Interface 3 (SCI3) can handle both asynchronous and clocked synchronous serial communication. In the asynchronous method, serial data communication can be carried out using standard asynchronous communication chips such as a Universal Asynchronous Receiver/Transmitter (UART) or an Asynchronous Communication Interface Adapter (ACIA). A function is also provided for serial communication between processors (multiprocessor communication function).

Figure 14.1 shows a block diagram of the SCI3.

14.1 Features

- Choice of asynchronous or clocked synchronous serial communication mode
- Full-duplex communication capability
The transmitter and receiver are mutually independent, enabling transmission and reception to be executed simultaneously.
Double-buffering is used in both the transmitter and the receiver, enabling continuous transmission and continuous reception of serial data.
- On-chip baud rate generator allows any bit rate to be selected
- External clock or on-chip baud rate generator can be selected as a transfer clock source.
- Six interrupt sources
Transmit-end, transmit-data-empty, receive-data-full, overrun error, framing error, and parity error.

Asynchronous mode

- Data length: 7 or 8 bits
- Stop bit length: 1 or 2 bits
- Parity: Even, odd, or none
- Receive error detection: Parity, overrun, and framing errors
- Break detection: Break can be detected by reading the RxD pin level directly in the case of a framing error

Clocked synchronous mode

- Data length: 8 bits
- Receive error detection: Overrun errors detected

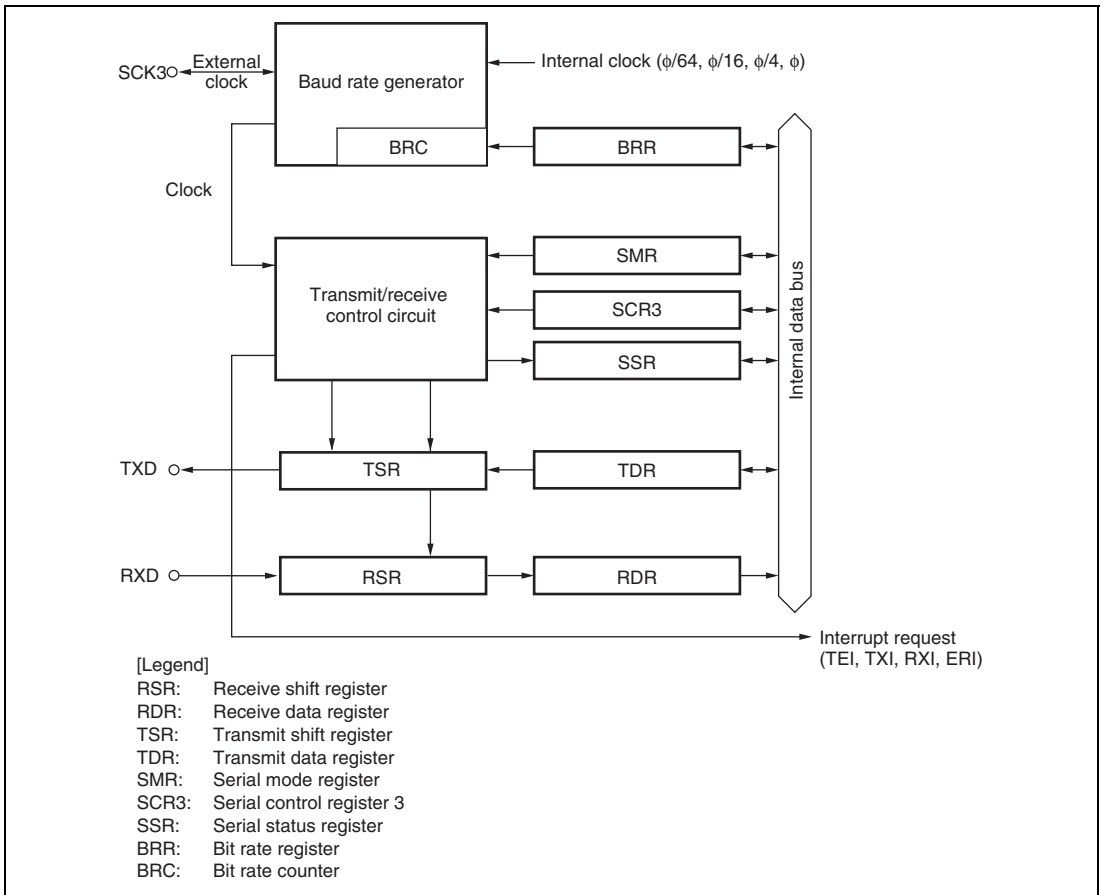

Figure 14.1 Block Diagram of SCI3

14.2 Input/Output Pins

Table 14.1 shows the SCI3 pin configuration.

Table 14.1 Pin Configuration

| Pin Name | Abbreviation | I/O | Function |
|---------------------------|--------------|--------|---------------------------|
| SCI3 clock | SCK3 | I/O | SCI3 clock input/output |
| SCI3 receive data input | RXD | Input | SCI3 receive data input |
| SCI3 transmit data output | TXD | Output | SCI3 transmit data output |

14.3 Register Descriptions

The SCI3 has the following registers.

- Receive shift register (RSR)
- Receive data register (RDR)
- Transmit shift register (TSR)
- Transmit data register (TDR)
- Serial mode register (SMR)
- Serial control register 3 (SCR3)
- Serial status register (SSR)
- Bit rate register (BRR)

14.3.1 Receive Shift Register (RSR)

RSR is a shift register that is used to receive serial data input from the RxD pin and convert it into parallel data. When one byte of data has been received, it is transferred to RDR automatically. RSR cannot be directly accessed by the CPU.

14.3.2 Receive Data Register (RDR)

RDR is an 8-bit register that stores received data. When the SCI3 has received one byte of serial data, it transfers the received serial data from RSR to RDR, where it is stored. After this, RSR is receive-enabled. As RSR and RDR function as a double buffer in this way, continuous receive operations are possible. After confirming that the RDRF bit in SSR is set to 1, read RDR only once. RDR cannot be written to by the CPU. RDR is initialized to H'00.

14.3.3 Transmit Shift Register (TSR)

TSR is a shift register that transmits serial data. To perform serial data transmission, the SCI3 first transfers transmit data from TDR to TSR automatically, then sends the data that starts from the LSB to the TXD pin. TSR cannot be directly accessed by the CPU.

14.3.4 Transmit Data Register (TDR)

TDR is an 8-bit register that stores data for transmission. When the SCI3 detects that TSR is empty, it transfers the transmit data written in TDR to TSR and starts transmission. The double-buffered structure of TDR and TSR enables continuous serial transmission. If the next transmit data has already been written to TDR during transmission of one-frame data, the SCI3 transfers the written data to TSR to continue transmission. To achieve reliable serial transmission, write transmit data to TDR only once after confirming that the TDRE bit in SSR is set to 1. TDR is initialized to H'FF.

14.3.5 Serial Mode Register (SMR)

SMR is used to set the SCI3's serial transfer format and select the on-chip baud rate generator clock source.

| Bit | Bit Name | Initial Value | R/W | Description |
|-----|----------|---------------|-----|--|
| 7 | COM | 0 | R/W | Communication Mode 0: Asynchronous mode 1: Clocked synchronous mode |
| 6 | CHR | 0 | R/W | Character Length (enabled only in asynchronous mode) 0: Selects 8 bits as the data length. 1: Selects 7 bits as the data length. |
| 5 | PE | 0 | R/W | Parity Enable (enabled only in asynchronous mode) When this bit is set to 1, the parity bit is added to transmit data before transmission, and the parity bit is checked in reception. |
| 4 | PM | 0 | R/W | Parity Mode (enabled only when the PE bit is 1 in asynchronous mode) 0: Selects even parity. 1: Selects odd parity. |
| 3 | STOP | 0 | R/W | Stop Bit Length (enabled only in asynchronous mode) Selects the stop bit length in transmission. 0: 1 stop bit 1: 2 stop bits For reception, only the first stop bit is checked, regardless of the value in the bit. If the second stop bit is 0, it is treated as the start bit of the next transmit character. |
| 2 | MP | 0 | R/W | Multiprocessor Mode When this bit is set to 1, the multiprocessor communication function is enabled. The PE bit and PM bit settings are invalid. In clocked synchronous mode, this bit should be cleared to 0. |

| Bit | Bit Name | Initial Value | R/W | Description |
|-----|----------|---------------|-----|---|
| 1 | CKS1 | 0 | R/W | Clock Select 0 and 1 |
| 0 | CKS0 | 0 | R/W | These bits select the clock source for the on-chip baud rate generator. 00: ϕ clock (n = 0) 01: $\phi/4$ clock (n = 1) 10: $\phi/16$ clock (n = 2) 11: $\phi/64$ clock (n = 3) For the relationship between the bit rate register setting and the baud rate, see section 14.3.8, Bit Rate Register (BRR). n is the decimal representation of the value of n in BRR (see section 14.3.8, Bit Rate Register (BRR)). |

14.3.6 Serial Control Register 3 (SCR3)

SCR3 is a register that enables or disables SCI3 transfer operations and interrupt requests, and is also used to select the transfer clock source. For details on interrupt requests, refer to section 14.7, Interrupts.

| Bit | Bit Name | Initial Value | R/W | Description |
|-----|----------|---------------|-----|--|
| 7 | TIE | 0 | R/W | Transmit Interrupt Enable When this bit is set to 1, the TXI interrupt request is enabled. |
| 6 | RIE | 0 | R/W | Receive Interrupt Enable When this bit is set to 1, RXI and ERI interrupt requests are enabled. |
| 5 | TE | 0 | R/W | Transmit Enable When this bit is set to 1, transmission is enabled. |
| 4 | RE | 0 | R/W | Receive Enable When this bit is set to 1, reception is enabled. |

| Bit | Bit Name | Initial Value | R/W | Description |
|-----|----------|---------------|-----|--|
| 3 | MPIE | 0 | R/W | <p>Multiprocessor Interrupt Enable (enabled only when the MP bit in SMR is 1 in asynchronous mode)</p> <p>When this bit is set to 1, receive data in which the multiprocessor bit is 0 is skipped, and setting of the RDRF, FER, and OER status flags in SSR is prohibited. On receiving data in which the multiprocessor bit is 1, this bit is automatically cleared and normal reception is resumed. For details, refer to section 14.6, Multiprocessor Communication Function.</p> |
| 2 | TEIE | 0 | R/W | <p>Transmit End Interrupt Enable</p> <p>When this bit is set to 1, the TEI interrupt request is enabled.</p> |
| 1 | CKE1 | 0 | R/W | Clock Enable 0 and 1 |
| 0 | CKE0 | 0 | R/W | <p>Selects the clock source.</p> <p>Asynchronous mode:</p> <p>00: Internal baud rate generator</p> <p>01: Internal baud rate generator</p> <p> Outputs a clock of the same frequency as the bit rate from the SCK3 pin.</p> <p>10: External clock</p> <p> Inputs a clock with a frequency 16 times the bit rate from the SCK3 pin.</p> <p>11: Reserved</p> <p> Clocked synchronous mode:</p> <p>00: Internal clock (SCK3 pin functions as clock output)</p> <p>01: Reserved</p> <p>10: External clock (SCK3 pin functions as clock input)</p> <p>11: Reserved</p> |

14.3.7 Serial Status Register (SSR)

SSR is a register containing status flags of the SCI3 and multiprocessor bits for transfer. 1 cannot be written to flags TDRE, RDRF, OER, PER, and FER; they can only be cleared.

| Bit | Bit Name | Initial Value | R/W | Description |
|-----|----------|---------------|-----|--|
| 7 | TDRE | 1 | R/W | Transmit Data Register Empty Displays whether TDR contains transmit data. [Setting conditions] <ul style="list-style-type: none"> • When the TE bit in SCR3 is 0 • When data is transferred from TDR to TSR [Clearing conditions] <ul style="list-style-type: none"> • When 0 is written to TDRE after reading TDRE = 1 • When the transmit data is written to TDR |
| 6 | RDRF | 0 | R/W | Receive Data Register Full Indicates that the received data is stored in RDR. [Setting condition] <ul style="list-style-type: none"> • When serial reception ends normally and receive data is transferred from RSR to RDR [Clearing conditions] <ul style="list-style-type: none"> • When 0 is written to RDRF after reading RDRF = 1 • When data is read from RDR |
| 5 | OER | 0 | R/W | Overrun Error [Setting condition] <ul style="list-style-type: none"> • When an overrun error occurs in reception [Clearing condition] <ul style="list-style-type: none"> • When 0 is written to OER after reading OER = 1 |
| 4 | FER | 0 | R/W | Framing Error [Setting condition] <ul style="list-style-type: none"> • When a framing error occurs in reception [Clearing condition] <ul style="list-style-type: none"> • When 0 is written to FER after reading FER = 1 |

| Bit | Bit Name | Initial Value | R/W | Description |
|-----|----------|---------------|-----|---|
| 3 | PER | 0 | R/W | <p>Parity Error</p> <p>[Setting condition]</p> <ul style="list-style-type: none"> When a parity error is generated during reception <p>[Clearing condition]</p> <ul style="list-style-type: none"> When 0 is written to PER after reading PER = 1 |
| 2 | TEND | 1 | R | <p>Transmit End</p> <p>[Setting conditions]</p> <ul style="list-style-type: none"> When the TE bit in SCR3 is 0 When TDRE = 1 at transmission of the last bit of a 1-byte serial transmit character <p>[Clearing conditions]</p> <ul style="list-style-type: none"> When 0 is written to TEND after reading TEND = 1 When the transmit data is written to TDR |
| 1 | MPBR | 0 | R | <p>Multiprocessor Bit Receive</p> <p>MPBR stores the multiprocessor bit in the receive character data. When the RE bit in SCR3 is cleared to 0, its previous state is retained.</p> |
| 0 | MPBT | 0 | R/W | <p>Multiprocessor Bit Transfer</p> <p>MPBT stores the multiprocessor bit to be added to the transmit character data.</p> |

14.3.8 Bit Rate Register (BRR)

BRR is an 8-bit register that adjusts the bit rate. The initial value of BRR is H'FF. Table 14.2 shows the relationship between the N setting in BRR and the n setting in bits CKS1 and CKS0 of SMR in asynchronous mode. Table 14.3 shows the maximum bit rate for each frequency in asynchronous mode. The values shown in both tables 14.2 and 14.3 are values in active (high-speed) mode. Table 14.4 shows the relationship between the N setting in BRR and the n setting in bits CKS1 and CKS0 in SMR in clocked synchronous mode. The values shown in table 14.4 are values in active (high-speed) mode. The N setting in BRR and error for other operating frequencies and bit rates can be obtained by the following formulas:

[Asynchronous Mode]

$$N = \frac{\phi}{64 \times 2^{2n-1} \times B} \times 10^6 - 1$$

$$\text{Error (\%)} = \left\{ \frac{\phi \times 10^6}{(N + 1) \times B \times 64 \times 2^{2n-1}} - 1 \right\} \times 100$$

[Clocked Synchronous Mode]

$$N = \frac{\phi}{8 \times 2^{2n-1} \times B} \times 10^6 - 1$$

Note: B: Bit rate (bit/s)

N: BRR setting for baud rate generator ($0 \leq N \leq 255$)

ϕ : Operating frequency (MHz)

n: CKS1 and CKS0 setting for SMR ($0 \leq n \leq 3$)

Table 14.2 Examples of BRR Settings for Various Bit Rates (Asynchronous Mode) (1)

| Bit Rate (bits/s) | Operating Frequency ϕ (MHz) | | | | | | | | | | | |
|----------------------|----------------------------------|-----|-----------|----------|-----|-----------|--------|-----|-----------|---|-----|-----------|
| | 2 | | | 2.097152 | | | 2.4576 | | | 3 | | |
| | n | N | Error (%) | n | N | Error (%) | n | N | Error (%) | n | N | Error (%) |
| 110 | 1 | 141 | 0.03 | 1 | 148 | -0.04 | 1 | 174 | -0.26 | 1 | 212 | 0.03 |
| 150 | 1 | 103 | 0.16 | 1 | 108 | 0.21 | 1 | 127 | 0.00 | 1 | 155 | 0.16 |
| 300 | 0 | 207 | 0.16 | 0 | 217 | 0.21 | 0 | 255 | 0.00 | 1 | 77 | 0.16 |
| 600 | 0 | 103 | 0.16 | 0 | 108 | 0.21 | 0 | 127 | 0.00 | 0 | 155 | 0.16 |
| 1200 | 0 | 51 | 0.16 | 0 | 54 | -0.70 | 0 | 63 | 0.00 | 0 | 77 | 0.16 |
| 2400 | 0 | 25 | 0.16 | 0 | 26 | 1.14 | 0 | 31 | 0.00 | 0 | 38 | 0.16 |
| 4800 | 0 | 12 | 0.16 | 0 | 13 | -2.48 | 0 | 15 | 0.00 | 0 | 19 | -2.34 |
| 9600 | 0 | 6 | -6.99 | 0 | 6 | -2.48 | 0 | 7 | 0.00 | 0 | 9 | -2.34 |
| 19200 | 0 | 2 | 8.51 | 0 | 2 | 13.78 | 0 | 3 | 0.00 | 0 | 4 | -2.34 |
| 31250 | 0 | 1 | 0.00 | 0 | 1 | 4.86 | 0 | 1 | 22.88 | 0 | 2 | 0.00 |
| 38400 | 0 | 1 | -18.62 | 0 | 1 | -14.67 | 0 | 1 | 0.00 | — | — | — |

Legend:

— : A setting is available but error occurs

| Bit Rate (bits/s) | Operating Frequency ϕ (MHz) | | | | | | | | | | | |
|----------------------|----------------------------------|-----|-----------|---|-----|-----------|--------|-----|-----------|---|-----|-----------|
| | 3.6864 | | | 4 | | | 4.9152 | | | 5 | | |
| | n | N | Error (%) | n | N | Error (%) | n | N | Error (%) | n | N | Error (%) |
| 110 | 2 | 64 | 0.70 | 2 | 70 | 0.03 | 2 | 86 | 0.31 | 2 | 88 | -0.25 |
| 150 | 1 | 191 | 0.00 | 1 | 207 | 0.16 | 1 | 255 | 0.00 | 2 | 64 | 0.16 |
| 300 | 1 | 95 | 0.00 | 1 | 103 | 0.16 | 1 | 127 | 0.00 | 1 | 129 | 0.16 |
| 600 | 0 | 191 | 0.00 | 0 | 207 | 0.16 | 0 | 255 | 0.00 | 1 | 64 | 0.16 |
| 1200 | 0 | 95 | 0.00 | 0 | 103 | 0.16 | 0 | 127 | 0.00 | 0 | 129 | 0.16 |
| 2400 | 0 | 47 | 0.00 | 0 | 51 | 0.16 | 0 | 63 | 0.00 | 0 | 64 | 0.16 |
| 4800 | 0 | 23 | 0.00 | 0 | 25 | 0.16 | 0 | 31 | 0.00 | 0 | 32 | -1.36 |
| 9600 | 0 | 11 | 0.00 | 0 | 12 | 0.16 | 0 | 15 | 0.00 | 0 | 15 | 1.73 |
| 19200 | 0 | 5 | 0.00 | 0 | 6 | -6.99 | 0 | 7 | 0.00 | 0 | 7 | 1.73 |
| 31250 | — | — | — | 0 | 3 | 0.00 | 0 | 4 | -1.70 | 0 | 4 | 0.00 |
| 38400 | 0 | 2 | 0.00 | 0 | 2 | 8.51 | 0 | 3 | 0.00 | 0 | 3 | 1.73 |

Table 14.2 Examples of BRR Settings for Various Bit Rates (Asynchronous Mode) (2)

| Bit Rate (bit/s) | Operating Frequency ϕ (MHz) | | | | | | | | | | | |
|---------------------|----------------------------------|-----|-----------|-------|-----|-----------|--------|-----|-----------|---|-----|-----------|
| | 6 | | | 6.144 | | | 7.3728 | | | 8 | | |
| | n | N | Error (%) | n | N | Error (%) | n | N | Error (%) | n | N | Error (%) |
| 110 | 2 | 106 | -0.44 | 2 | 108 | 0.08 | 2 | 130 | -0.07 | 2 | 141 | 0.03 |
| 150 | 2 | 77 | 0.16 | 2 | 79 | 0.00 | 2 | 95 | 0.00 | 2 | 103 | 0.16 |
| 300 | 1 | 155 | 0.16 | 1 | 159 | 0.00 | 1 | 191 | 0.00 | 1 | 207 | 0.16 |
| 600 | 1 | 77 | 0.16 | 1 | 79 | 0.00 | 1 | 95 | 0.00 | 1 | 103 | 0.16 |
| 1200 | 0 | 155 | 0.16 | 0 | 159 | 0.00 | 0 | 191 | 0.00 | 0 | 207 | 0.16 |
| 2400 | 0 | 77 | 0.16 | 0 | 79 | 0.00 | 0 | 95 | 0.00 | 0 | 103 | 0.16 |
| 4800 | 0 | 38 | 0.16 | 0 | 39 | 0.00 | 0 | 47 | 0.00 | 0 | 51 | 0.16 |
| 9600 | 0 | 19 | -2.34 | 0 | 19 | 0.00 | 0 | 23 | 0.00 | 0 | 25 | 0.16 |
| 19200 | 0 | 9 | -2.34 | 0 | 9 | 0.00 | 0 | 11 | 0.00 | 0 | 12 | 0.16 |
| 31250 | 0 | 5 | 0.00 | 0 | 5 | 2.40 | 0 | 6 | 5.33 | 0 | 7 | 0.00 |
| 38400 | 0 | 4 | -2.34 | 0 | 4 | 0.00 | 0 | 5 | 0.00 | 0 | 6 | -6.99 |

| Bit Rate (bit/s) | Operating Frequency ϕ (MHz) | | | | | | | | | | | |
|---------------------|----------------------------------|-----|-----------|----|-----|-----------|----|-----|-----------|--------|-----|-----------|
| | 9.8304 | | | 10 | | | 12 | | | 12.888 | | |
| | n | N | Error (%) | n | N | Error (%) | n | N | Error (%) | n | N | Error (%) |
| 110 | 2 | 174 | -0.26 | 2 | 177 | -0.25 | 2 | 212 | 0.03 | 2 | 217 | 0.08 |
| 150 | 2 | 127 | 0.00 | 2 | 129 | 0.16 | 2 | 155 | 0.16 | 2 | 159 | 0.00 |
| 300 | 1 | 255 | 0.00 | 2 | 64 | 0.16 | 2 | 77 | 0.16 | 2 | 79 | 0.00 |
| 600 | 1 | 127 | 0.00 | 1 | 129 | 0.16 | 1 | 155 | 0.16 | 1 | 159 | 0.00 |
| 1200 | 0 | 255 | 0.00 | 1 | 64 | 0.16 | 1 | 77 | 0.16 | 1 | 79 | 0.00 |
| 2400 | 0 | 127 | 0.00 | 0 | 129 | 0.16 | 0 | 155 | 0.16 | 0 | 159 | 0.00 |
| 4800 | 0 | 63 | 0.00 | 0 | 64 | 0.16 | 0 | 77 | 0.16 | 0 | 79 | 0.00 |
| 9600 | 0 | 31 | 0.00 | 0 | 32 | -1.36 | 0 | 38 | 0.16 | 0 | 39 | 0.00 |
| 19200 | 0 | 15 | 0.00 | 0 | 15 | 1.73 | 0 | 19 | -2.34 | 0 | 19 | 0.00 |
| 31250 | 0 | 9 | -1.70 | 0 | 9 | 0.00 | 0 | 11 | 0.00 | 0 | 11 | 2.40 |
| 38400 | 0 | 7 | 0.00 | 0 | 7 | 1.73 | 0 | 9 | -2.34 | 0 | 9 | 0.00 |

Table 14.2 Examples of BRR Settings for Various Bit Rates (Asynchronous Mode) (3)

| Bit Rate (bit/s) | Operating Frequency ϕ (MHz) | | | | | | | | |
|---------------------|----------------------------------|-----|-----------|---------|-----|-----------|----|-----|-----------|
| | 14 | | | 14.7456 | | | 16 | | |
| | n | N | Error (%) | n | N | Error (%) | n | N | Error (%) |
| 110 | 2 | 248 | -0.17 | 3 | 64 | 0.70 | 3 | 70 | 0.03 |
| 150 | 2 | 181 | 0.16 | 2 | 191 | 0.00 | 2 | 207 | 0.16 |
| 300 | 2 | 90 | 0.16 | 2 | 95 | 0.00 | 2 | 103 | 0.16 |
| 600 | 1 | 181 | 0.16 | 1 | 191 | 0.00 | 1 | 207 | 0.16 |
| 1200 | 1 | 90 | 0.16 | 1 | 95 | 0.00 | 1 | 103 | 0.16 |
| 2400 | 0 | 181 | 0.16 | 0 | 191 | 0.00 | 0 | 207 | 0.16 |
| 4800 | 0 | 90 | 0.16 | 0 | 95 | 0.00 | 0 | 103 | 0.16 |
| 9600 | 0 | 45 | -0.93 | 0 | 47 | 0.00 | 0 | 51 | 0.16 |
| 19200 | 0 | 22 | -0.93 | 0 | 23 | 0.00 | 0 | 25 | 0.16 |
| 31250 | 0 | 13 | 0.00 | 0 | 14 | -1.70 | 0 | 15 | 0.00 |
| 38400 | — | — | — | 0 | 11 | 0.00 | 0 | 12 | 0.16 |

| Bit Rate (bit/s) | Operating Frequency ϕ (MHz) | | | | | |
|---------------------|----------------------------------|-----|-----------|----|-----|-----------|
| | 18 | | | 20 | | |
| | n | N | Error (%) | n | N | Error (%) |
| 110 | 3 | 79 | -0.12 | 3 | 88 | -0.25 |
| 150 | 2 | 233 | 0.16 | 3 | 64 | 0.16 |
| 300 | 2 | 116 | 0.16 | 2 | 129 | 0.16 |
| 600 | 1 | 233 | 0.16 | 2 | 64 | 0.16 |
| 1200 | 1 | 116 | 0.16 | 1 | 129 | 0.16 |
| 2400 | 0 | 233 | 0.16 | 1 | 64 | 0.16 |
| 4800 | 0 | 116 | 0.16 | 0 | 129 | 0.16 |
| 9600 | 0 | 58 | -0.96 | 0 | 64 | 0.16 |
| 19200 | 0 | 28 | 1.02 | 0 | 32 | -1.36 |
| 31250 | 0 | 17 | 0.00 | 0 | 19 | 0.00 |
| 38400 | 0 | 14 | -2.34 | 0 | 15 | 1.73 |

Legend:

—: A setting is available but error occurs.

Table 14.3 Maximum Bit Rate for Each Frequency (Asynchronous Mode)

| ϕ (MHz) | Maximum Bit Rate (bit/s) | n | N | ϕ (MHz) | Maximum Bit Rate (bit/s) | n | N |
|--------------|--------------------------|---|---|--------------|--------------------------|---|---|
| 2 | 62500 | 0 | 0 | 8 | 250000 | 0 | 0 |
| 2.097152 | 65536 | 0 | 0 | 9.8304 | 307200 | 0 | 0 |
| 2.4576 | 76800 | 0 | 0 | 10 | 312500 | 0 | 0 |
| 3 | 93750 | 0 | 0 | 12 | 375000 | 0 | 0 |
| 3.6864 | 115200 | 0 | 0 | 12.288 | 384000 | 0 | 0 |
| 4 | 125000 | 0 | 0 | 14 | 437500 | 0 | 0 |
| 4.9152 | 153600 | 0 | 0 | 14.7456 | 460800 | 0 | 0 |
| 5 | 156250 | 0 | 0 | 16 | 500000 | 0 | 0 |
| 6 | 187500 | 0 | 0 | 17.2032 | 537600 | 0 | 0 |
| 6.144 | 192000 | 0 | 0 | 18 | 562500 | 0 | 0 |
| 7.3728 | 230400 | 0 | 0 | 20 | 625000 | 0 | 0 |

Table 14.4 Examples of BBR Setting for Various Bit Rates (Clocked Synchronous Mode)
(1)

| Bit Rate (bit/s) | Operating Frequency ϕ (MHz) | | | | | | | | | |
|---------------------|----------------------------------|-----|---|-----|---|-----|----|-----|----|-----|
| | 2 | | 4 | | 8 | | 10 | | 16 | |
| | n | N | n | N | n | N | n | N | n | N |
| 110 | 3 | 70 | — | — | — | — | — | — | | |
| 250 | 2 | 124 | 2 | 249 | 3 | 124 | — | — | 3 | 249 |
| 500 | 1 | 249 | 2 | 124 | 2 | 249 | — | — | 3 | 124 |
| 1k | 1 | 124 | 1 | 249 | 2 | 124 | — | — | 2 | 249 |
| 2.5k | 0 | 199 | 1 | 99 | 1 | 199 | 1 | 249 | 2 | 99 |
| 5k | 0 | 99 | 0 | 199 | 1 | 99 | 1 | 124 | 1 | 199 |
| 10k | 0 | 49 | 0 | 99 | 0 | 199 | 0 | 249 | 1 | 99 |
| 25k | 0 | 19 | 0 | 39 | 0 | 79 | 0 | 99 | 0 | 159 |
| 50k | 0 | 9 | 0 | 19 | 0 | 39 | 0 | 49 | 0 | 79 |
| 100k | 0 | 4 | 0 | 9 | 0 | 19 | 0 | 24 | 0 | 39 |
| 250k | 0 | 1 | 0 | 3 | 0 | 7 | 0 | 9 | 0 | 15 |
| 500k | 0 | 0* | 0 | 1 | 0 | 3 | 0 | 4 | 0 | 7 |
| 1M | | | 0 | 0* | 0 | 1 | — | — | 0 | 3 |
| 2M | | | | | 0 | 0* | — | — | 0 | 1 |
| 2.5M | | | | | | | 0 | 0* | — | — |
| 4M | | | | | | | | | 0 | 0* |

Legend:

Blank : No setting is available.

— : A setting is available but error occurs.

* : Continuous transfer is not possible.

Table 14.4 Examples of BRR Settings for Various Bit Rates (Clocked Synchronous Mode)
(2)

| Bit Rate (bit/s) | Operating Frequency ϕ (MHz) | | | |
|---------------------|----------------------------------|-----|----|-----|
| | 18 | | 20 | |
| | n | N | n | N |
| 110 | — | — | — | — |
| 250 | — | — | — | — |
| 500 | 3 | 140 | 3 | 155 |
| 1k | 3 | 69 | 3 | 77 |
| 2.5k | 2 | 112 | 2 | 124 |
| 5k | 1 | 224 | 1 | 249 |
| 10k | 1 | 112 | 1 | 124 |
| 25k | 0 | 179 | 0 | 199 |
| 50k | 0 | 89 | 0 | 99 |
| 100k | 0 | 44 | 0 | 49 |
| 250k | 0 | 17 | 0 | 19 |
| 500k | 0 | 8 | 0 | 9 |
| 1M | 0 | 4 | 0 | 4 |
| 2M | — | — | — | — |
| 2.5M | — | — | 0 | 1 |
| 4M | — | — | — | — |

Legend:

Blank : No setting is available.

— : A setting is available but error occurs.

* : Continuous transfer is not possible.

14.4 Operation in Asynchronous Mode

Figure 14.2 shows the general format for asynchronous serial communication. One frame consists of a start bit (low level), followed by data (in LSB-first order), a parity bit (high or low level), and finally stop bits (high level). Inside the SCI3, the transmitter and receiver are independent units, enabling full duplex. Both the transmitter and the receiver also have a double-buffered structure, so data can be read or written during transmission or reception, enabling continuous data transfer.

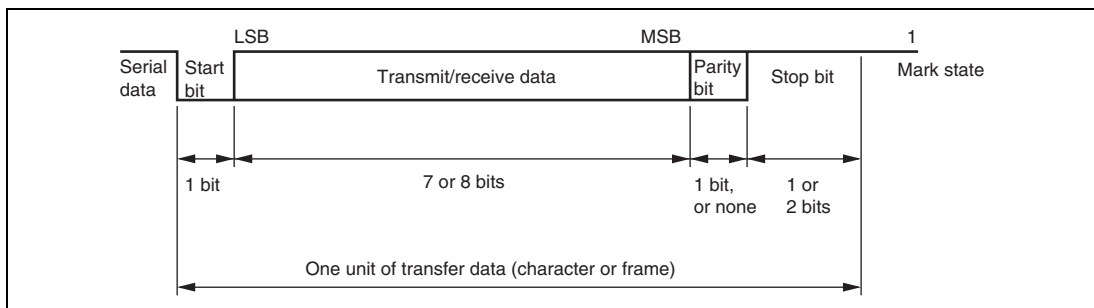

Figure 14.2 Data Format in Asynchronous Communication

14.4.1 Clock

Either an internal clock generated by the on-chip baud rate generator or an external clock input at the SCK3 pin can be selected as the SCI3's serial clock source, according to the setting of the COM bit in SMR and the CKE0 and CKE1 bits in SCR3. When an external clock is input at the SCK3 pin, the clock frequency should be 16 times the bit rate used.

When the SCI3 is operated on an internal clock, the clock can be output from the SCK3 pin. The frequency of the clock output in this case is equal to the bit rate, and the phase is such that the rising edge of the clock is in the middle of the transmit data, as shown in figure 14.3.

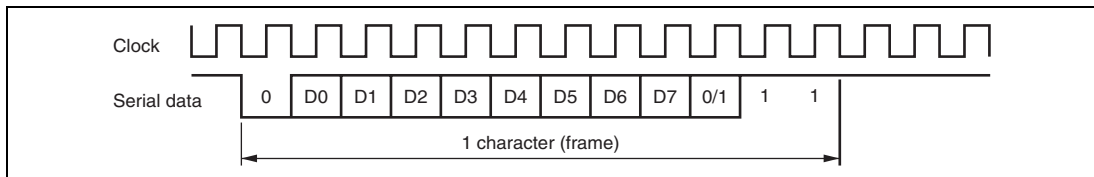

Figure 14.3 Relationship between Output Clock and Transfer Data Phase (Asynchronous Mode) (Example with 8-Bit Data, Parity, Two Stop Bits)

14.4.2 SCI3 Initialization

Follow the flowchart as shown in figure 14.4 to initialize the SCI3. When the TE bit is cleared to 0, the TDRE flag is set to 1. Note that clearing the RE bit to 0 does not initialize the contents of the RDRF, PER, FER, and OER flags, or the contents of RDR. When the external clock is used in asynchronous mode, the clock must be supplied even during initialization.

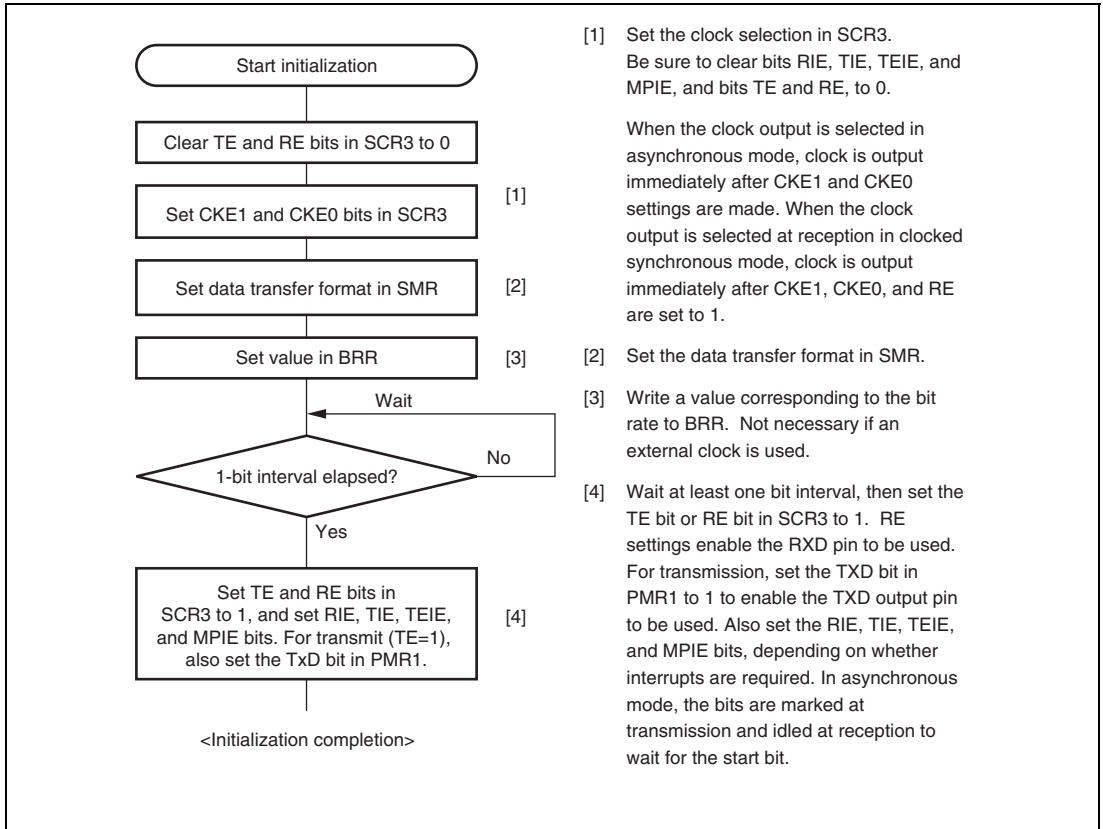

Figure 14.4 Sample SCI3 Initialization Flowchart

14.4.3 Data Transmission

Figure 14.5 shows an example of operation for transmission in asynchronous mode. In transmission, the SCI3 operates as described below.

1. The SCI3 monitors the TDRE flag in SSR. If the flag is cleared to 0, the SCI3 recognizes that data has been written to TDR, and transfers the data from TDR to TSR.
2. After transferring data from TDR to TSR, the SCI3 sets the TDRE flag to 1 and starts transmission. If the TIE bit is set to 1 at this time, a TXI interrupt request is generated. Continuous transmission is possible because the TXI interrupt routine writes next transmit data to TDR before transmission of the current transmit data has been completed.
3. The SCI3 checks the TDRE flag at the timing for sending the stop bit.
4. If the TDRE flag is 0, the data is transferred from TDR to TSR, the stop bit is sent, and then serial transmission of the next frame is started.
5. If the TDRE flag is 1, the TEND flag in SSR is set to 1, the stop bit is sent, and then the “mark state” is entered, in which 1 is output. If the TEIE bit in SCR3 is set to 1 at this time, a TEI interrupt request is generated.
6. Figure 14.6 shows a sample flowchart for transmission in asynchronous mode.

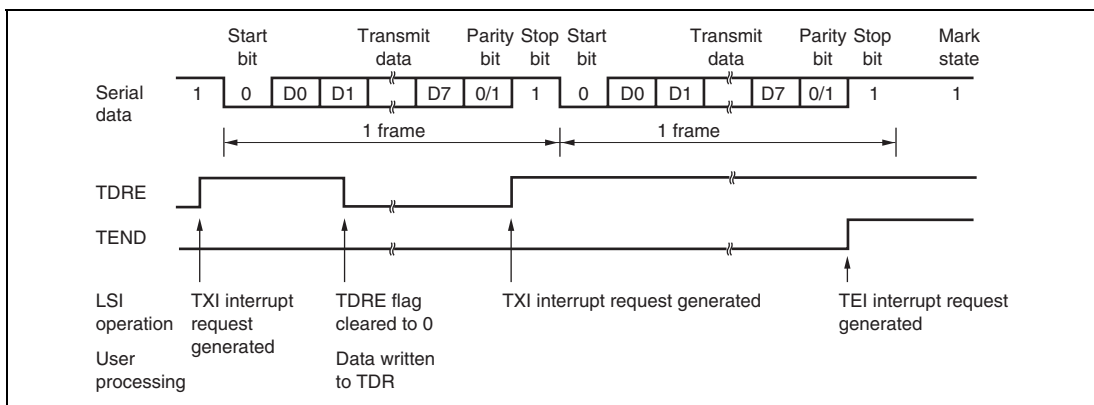

Figure 14.5 Example SCI3 Operation in Transmission in Asynchronous Mode (8-Bit Data, Parity, One Stop Bit)

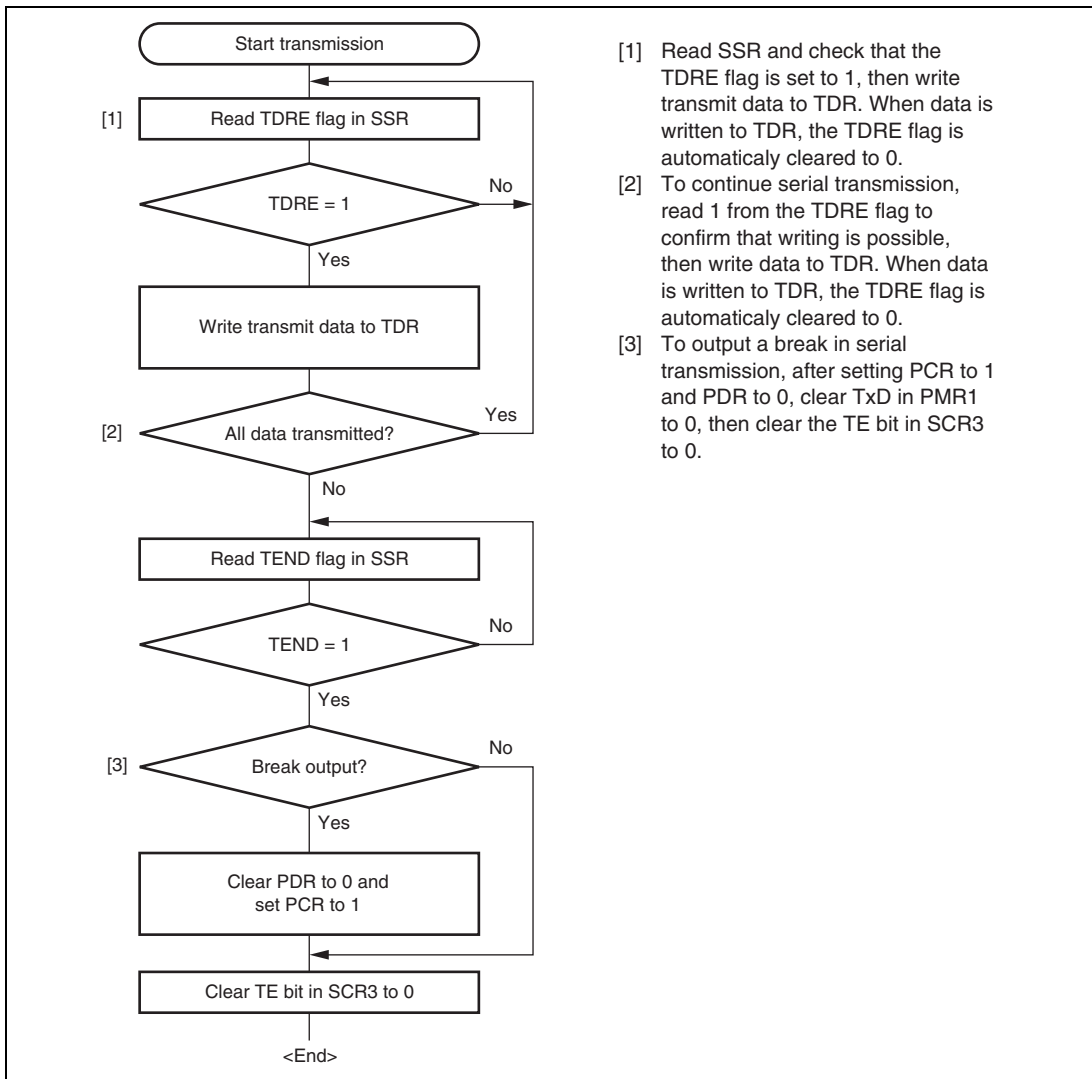

Figure 14.6 Sample Serial Transmission Flowchart (Asynchronous Mode)

14.4.4 Serial Data Reception

Figure 14.7 shows an example of operation for reception in asynchronous mode. In serial reception, the SCI operates as described below.

1. The SCI3 monitors the communication line. If a start bit is detected, the SCI3 performs internal synchronization, receives data in RSR, and checks the parity bit and stop bit.
2. If an overrun error occurs (when reception of the next data is completed while the RDRF flag is still set to 1), the OER bit in SSR is set to 1. If the RIE bit in SCR3 is set to 1 at this time, an ERI interrupt request is generated. Receive data is not transferred to RDR.
3. If a parity error is detected, the PER bit in SSR is set to 1 and receive data is transferred to RDR. If the RIE bit in SCR3 is set to 1 at this time, an ERI interrupt request is generated.
4. If a framing error is detected (when the stop bit is 0), the FER bit in SSR is set to 1 and receive data is transferred to RDR. If the RIE bit in SCR3 is set to 1 at this time, an ERI interrupt request is generated.
5. If reception is completed successfully, the RDRF bit in SSR is set to 1, and receive data is transferred to RDR. If the RIE bit in SCR3 is set to 1 at this time, an RXI interrupt request is generated. Continuous reception is possible because the RXI interrupt routine reads the receive data transferred to RDR before reception of the next receive data has been completed.

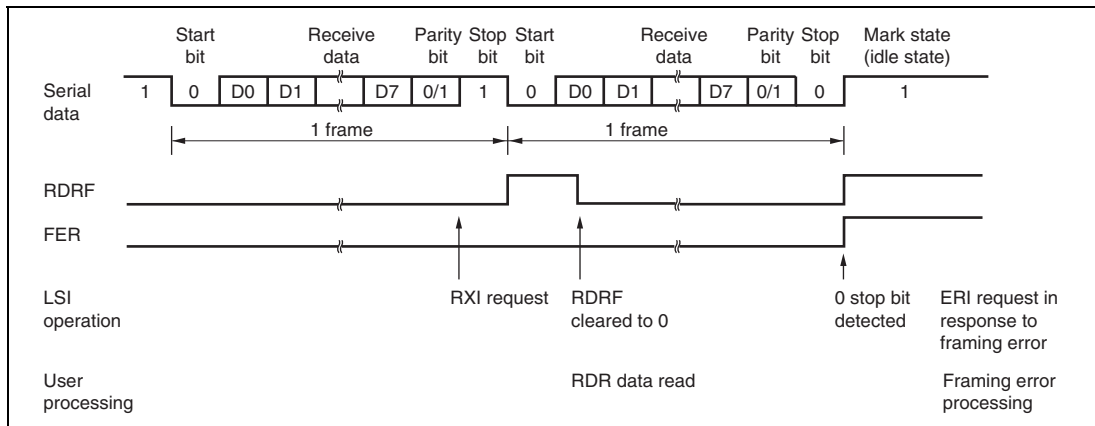

Figure 14.7 Example SCI3 Operation in Reception in Asynchronous Mode (8-Bit Data, Parity, One Stop Bit)

Table 14.5 shows the states of the SSR status flags and receive data handling when a receive error is detected. If a receive error is detected, the RDRF flag retains its state before receiving data. Reception cannot be resumed while a receive error flag is set to 1. Accordingly, clear the OER, FER, PER, and RDRF bits to 0 before resuming reception. Figure 14.8 shows a sample flowchart for serial data reception.

Table 14.5 SSR Status Flags and Receive Data Handling

| SSR Status Flag | | | | Receive Data | Receive Error Type |
|-----------------|-----|-----|-----|--------------------|--|
| RDRF* | OER | FER | PER | | |
| 1 | 1 | 0 | 0 | Lost | Overrun error |
| 0 | 0 | 1 | 0 | Transferred to RDR | Framing error |
| 0 | 0 | 0 | 1 | Transferred to RDR | Parity error |
| 1 | 1 | 1 | 0 | Lost | Overrun error + framing error |
| 1 | 1 | 0 | 1 | Lost | Overrun error + parity error |
| 0 | 0 | 1 | 1 | Transferred to RDR | Framing error + parity error |
| 1 | 1 | 1 | 1 | Lost | Overrun error + framing error + parity error |

Note: * The RDRF flag retains the state it had before data reception.

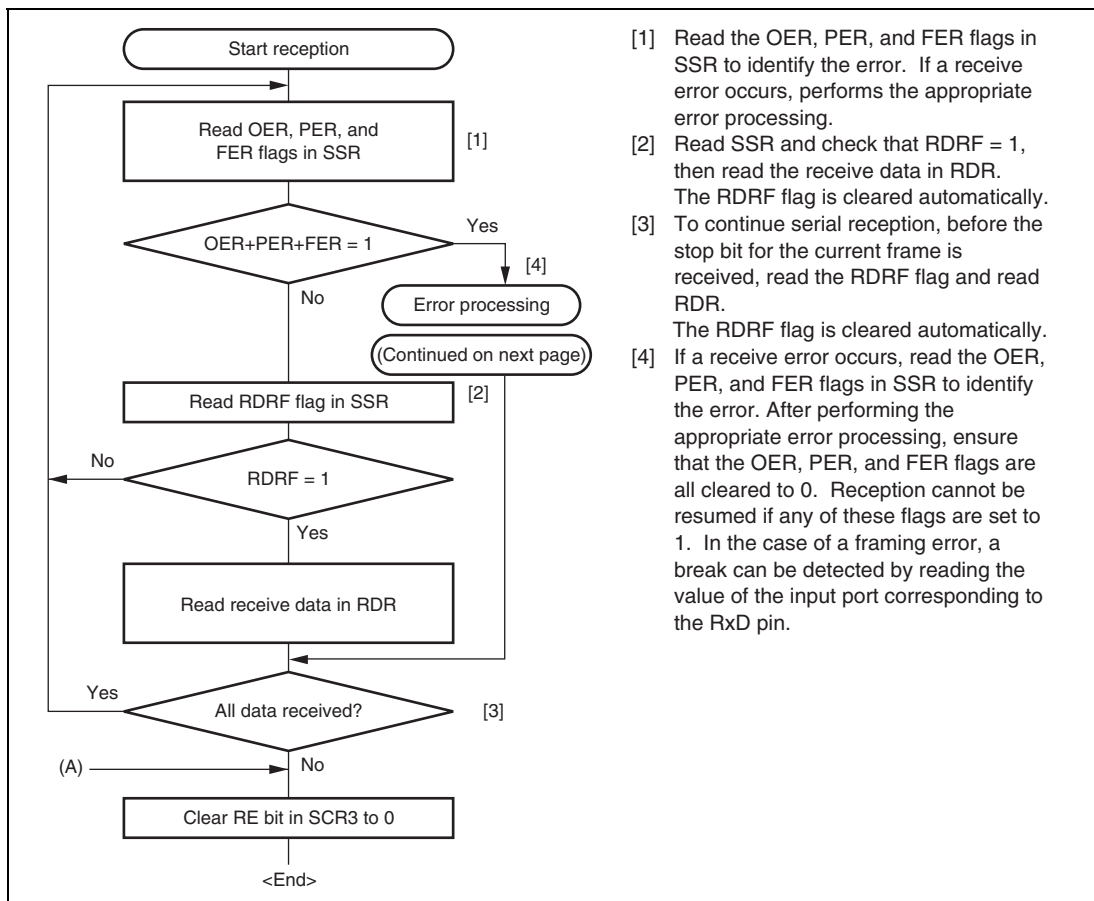

Figure 14.8 Sample Serial Data Reception Flowchart (Asynchronous mode) (1)

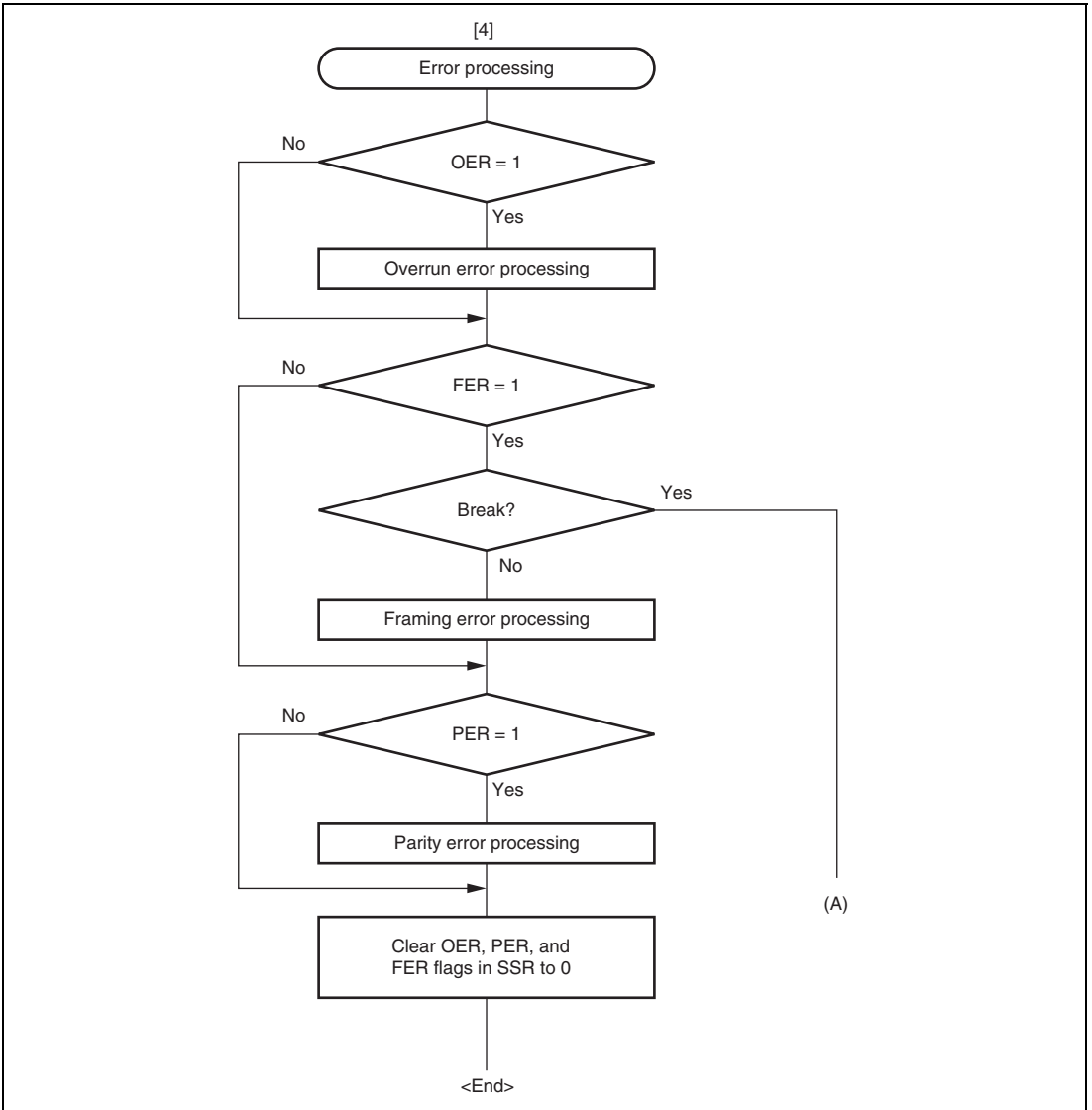

Figure 14.8 Sample Serial Reception Data Flowchart (2)

14.5 Operation in Clocked Synchronous Mode

Figure 14.9 shows the general format for clocked synchronous communication. In clocked synchronous mode, data is transmitted or received synchronous with clock pulses. A single character in the transmit data consists of the 8-bit data starting from the LSB. In clocked synchronous serial communication, data on the transmission line is output from one falling edge of the serial clock to the next. In clocked synchronous mode, the SCI3 receives data in synchronous with the rising edge of the serial clock. After 8-bit data is output, the transmission line holds the MSB state. In clocked synchronous mode, no parity or multiprocessor bit is added. Inside the SCI3, the transmitter and receiver are independent units, enabling full-duplex communication through the use of a common clock. Both the transmitter and the receiver also have a double-buffered structure, so data can be read or written during transmission or reception, enabling continuous data transfer.

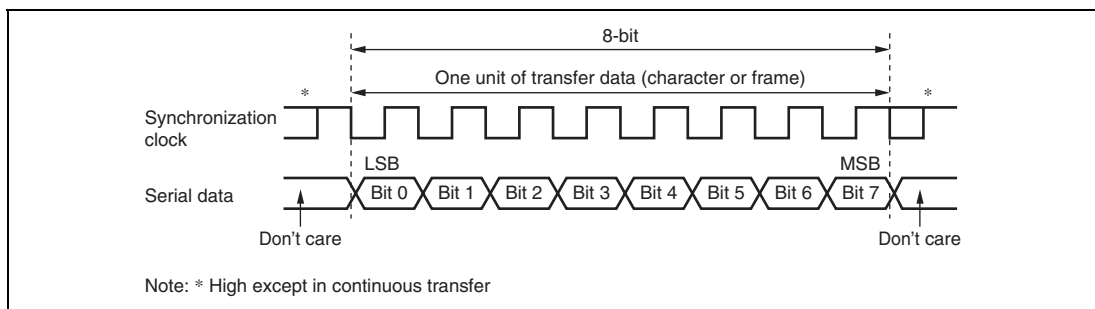

Figure 14.9 Data Format in Clocked Synchronous Communication

14.5.1 Clock

Either an internal clock generated by the on-chip baud rate generator or an external synchronization clock input at the SCK3 pin can be selected, according to the setting of the COM bit in SMR and CKE0 and CKE1 bits in SCR3. When the SCI3 is operated on an internal clock, the serial clock is output from the SCK3 pin. Eight serial clock pulses are output in the transfer of one character, and when no transfer is performed the clock is fixed high.

14.5.2 SCI3 Initialization

Before transmitting and receiving data, the SCI3 should be initialized as described in a sample flowchart in figure 14.4.

14.5.3 Serial Data Transmission

Figure 14.10 shows an example of SCI3 operation for transmission in clocked synchronous mode. In serial transmission, the SCI3 operates as described below.

1. The SCI3 monitors the TDRE flag in SSR, and if the flag is 0, the SCI recognizes that data has been written to TDR, and transfers the data from TDR to TSR.
2. The SCI3 sets the TDRE flag to 1 and starts transmission. If the TIE bit in SCR3 is set to 1 at this time, a transmit data empty interrupt (TXI) is generated.
3. 8-bit data is sent from the TxD pin synchronized with the output clock when output clock mode has been specified, and synchronized with the input clock when use of an external clock has been specified. Serial data is transmitted sequentially from the LSB (bit 0), from the TXD pin.
4. The SCI checks the TDRE flag at the timing for sending the MSB (bit 7).
5. If the TDRE flag is cleared to 0, data is transferred from TDR to TSR, and serial transmission of the next frame is started.
6. If the TDRE flag is set to 1, the TEND flag in SSR is set to 1, and the TDRE flag maintains the output state of the last bit. If the TEIE bit in SCR3 is set to 1 at this time, a TEI interrupt request is generated.
7. The SCK3 pin is fixed high.

Figure 14.11 shows a sample flowchart for serial data transmission. Even if the TDRE flag is cleared to 0, transmission will not start while a receive error flag (OER, FER, or PER) is set to 1. Make sure that the receive error flags are cleared to 0 before starting transmission.

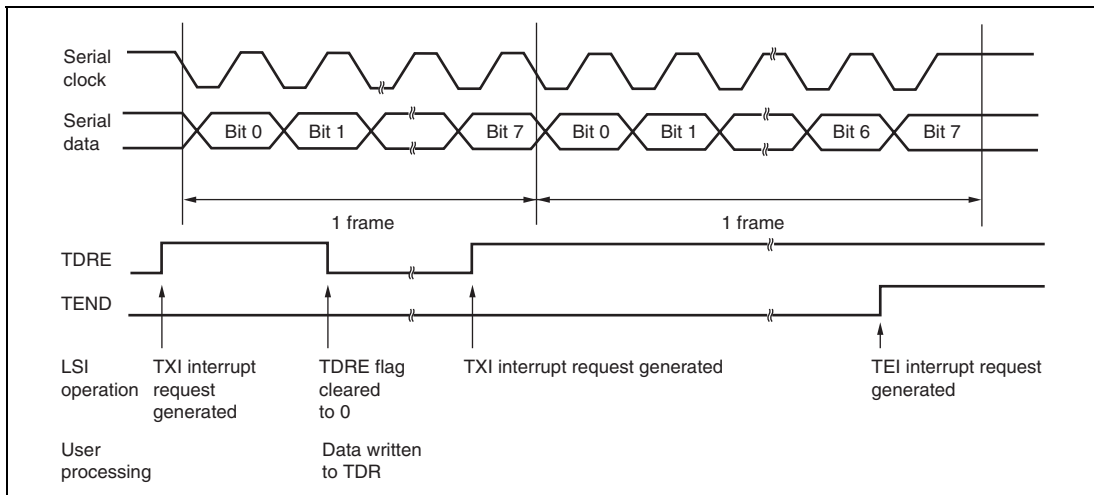

Figure 14.10 Example of SCI3 Operation in Transmission in Clocked Synchronous Mode

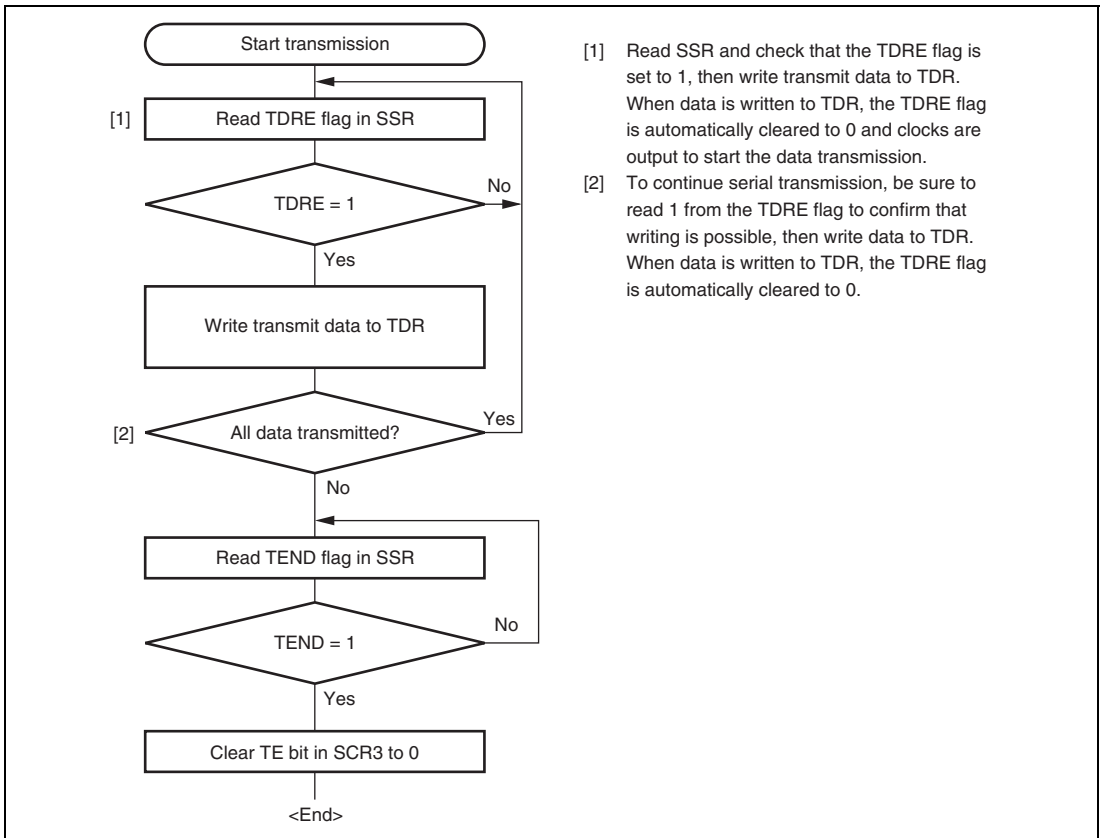

Figure 14.11 Sample Serial Transmission Flowchart (Clocked Synchronous Mode)

14.5.4 Serial Data Reception (Clocked Synchronous Mode)

Figure 14.12 shows an example of SCI3 operation for reception in clocked synchronous mode. In serial reception, the SCI3 operates as described below.

1. The SCI3 performs internal initialization synchronous with a synchronous clock input or output, starts receiving data.
2. The SCI3 stores the received data in RSR.
3. If an overrun error occurs (when reception of the next data is completed while the RDRF flag in SSR is still set to 1), the OER bit in SSR is set to 1. If the RIE bit in SCR3 is set to 1 at this time, an ERI interrupt request is generated, receive data is not transferred to RDR, and the RDRF flag remains to be set to 1.
4. If reception is completed successfully, the RDRF bit in SSR is set to 1, and receive data is transferred to RDR. If the RIE bit in SCR3 is set to 1 at this time, an RXI interrupt request is generated.

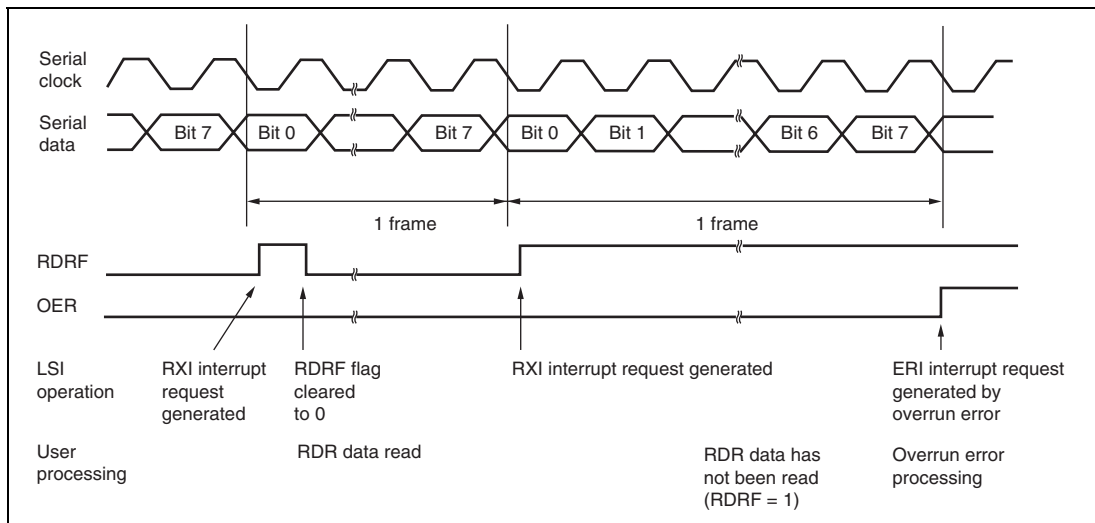

Figure 14.12 Example of SCI3 Reception Operation in Clocked Synchronous Mode

Reception cannot be resumed while a receive error flag is set to 1. Accordingly, clear the OER, FER, PER, and RDRF bits to 0 before resuming reception. Figure 14.13 shows a sample flowchart for serial data reception.

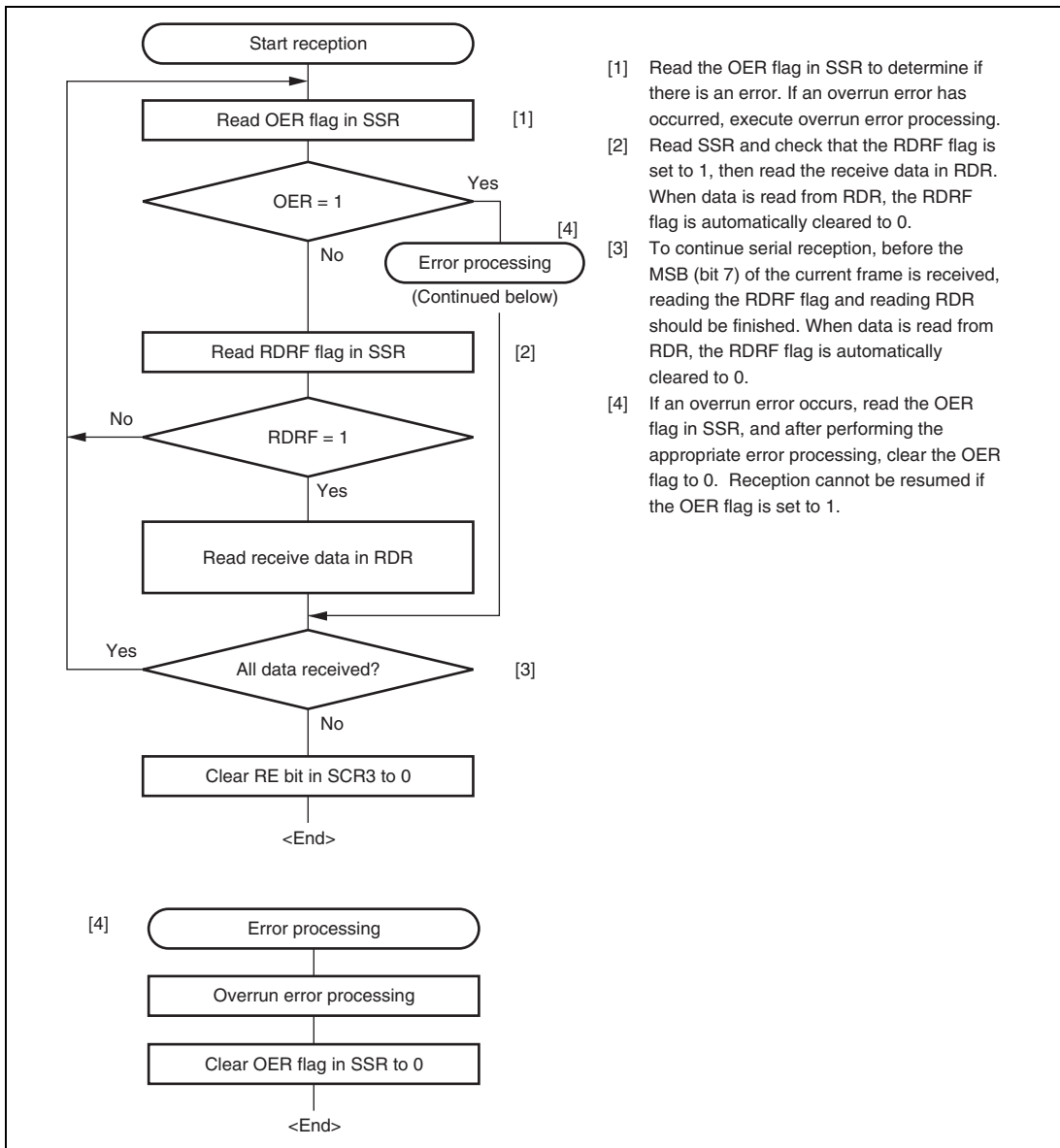

Figure 14.13 Sample Serial Reception Flowchart (Clocked Synchronous Mode)

14.5.5 Simultaneous Serial Data Transmission and Reception

Figure 14.14 shows a sample flowchart for simultaneous serial transmit and receive operations. The following procedure should be used for simultaneous serial data transmit and receive operations. To switch from transmit mode to simultaneous transmit and receive mode, after checking that the SCI3 has finished transmission and the TDRE and TEND flags are set to 1, clear TE to 0. Then simultaneously set TE and RE to 1 with a single instruction. To switch from receive mode to simultaneous transmit and receive mode, after checking that the SCI3 has finished reception, clear RE to 0. Then after checking that the RDRF and receive error flags (OER, FER, and PER) are cleared to 0, simultaneously set TE and RE to 1 with a single instruction.

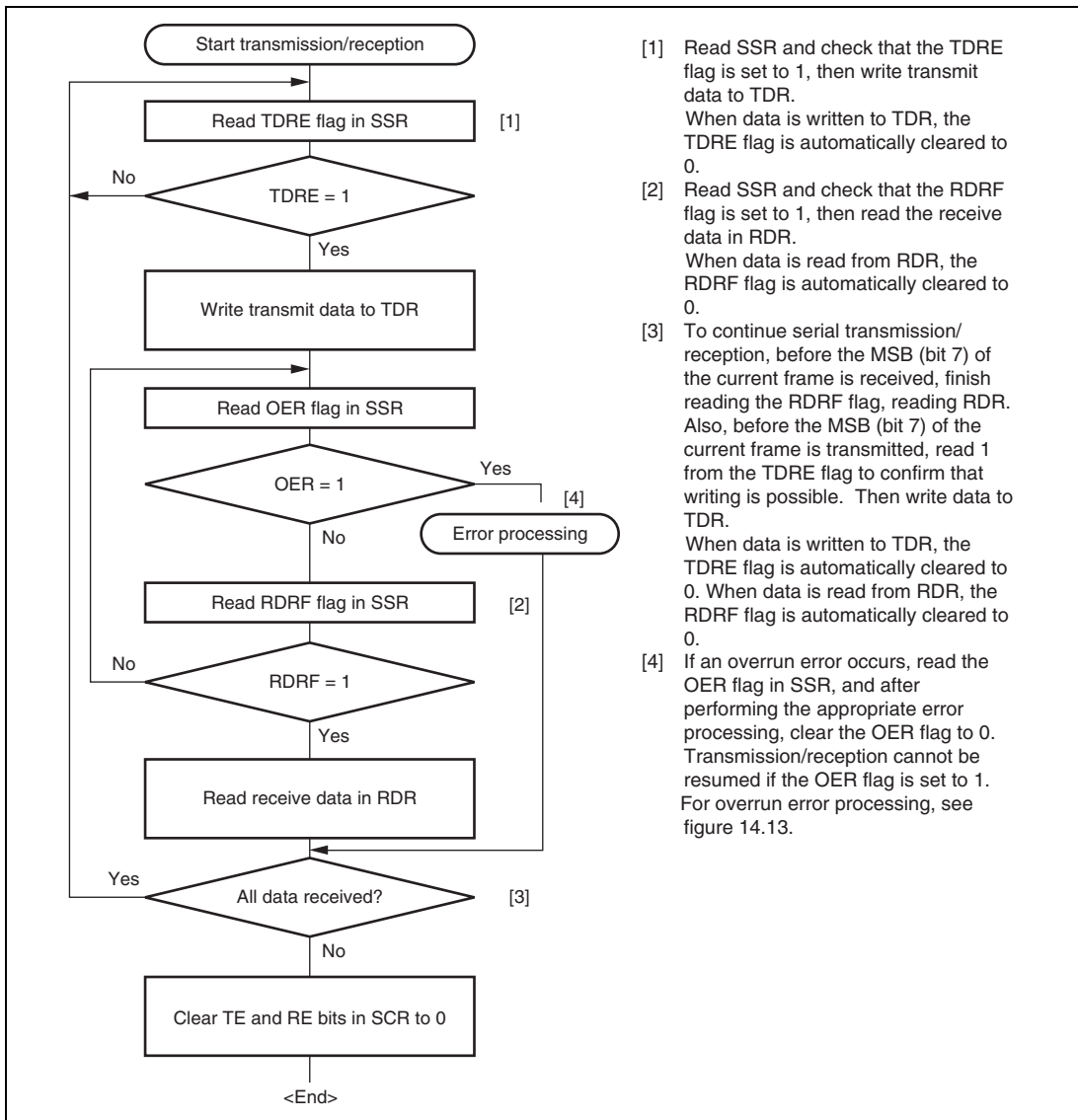

Figure 14.14 Sample Flowchart of Simultaneous Serial Transmit and Receive Operations (Clocked Synchronous Mode)

14.6 Multiprocessor Communication Function

Use of the multiprocessor communication function enables data transfer between a number of processors sharing communication lines by asynchronous serial communication using the multiprocessor format, in which a multiprocessor bit is added to the transfer data. When multiprocessor communication is performed, each receiving station is addressed by a unique ID code. The serial communication cycle consists of two component cycles; an ID transmission cycle that specifies the receiving station, and a data transmission cycle. The multiprocessor bit is used to differentiate between the ID transmission cycle and the data transmission cycle. If the multiprocessor bit is 1, the cycle is an ID transmission cycle; if the multiprocessor bit is 0, the cycle is a data transmission cycle. Figure 14.15 shows an example of inter-processor communication using the multiprocessor format. The transmitting station first sends the ID code of the receiving station with which it wants to perform serial communication as data with a 1 multiprocessor bit added. It then sends transmit data as data with a 0 multiprocessor bit added. When data with a 1 multiprocessor bit is received, the receiving station compares that data with its own ID. The station whose ID matches then receives the data sent next. Stations whose IDs do not match continue to skip data until data with a 1 multiprocessor bit is again received.

The SCI3 uses the MPIE bit in SCR3 to implement this function. When the MPIE bit is set to 1, transfer of receive data from RSR to RDR, error flag detection, and setting the SSR status flags, RDRF, FER, and OER to 1, are inhibited until data with a 1 multiprocessor bit is received. On reception of a receive character with a 1 multiprocessor bit, the MPBR bit in SSR is set to 1 and the MPIE bit is automatically cleared, thus normal reception is resumed. If the RIE bit in SCR3 is set to 1 at this time, an RXI interrupt is generated.

When the multiprocessor format is selected, the parity bit setting is rendered invalid. All other bit settings are the same as those in normal asynchronous mode. The clock used for multiprocessor communication is the same as that in normal asynchronous mode.

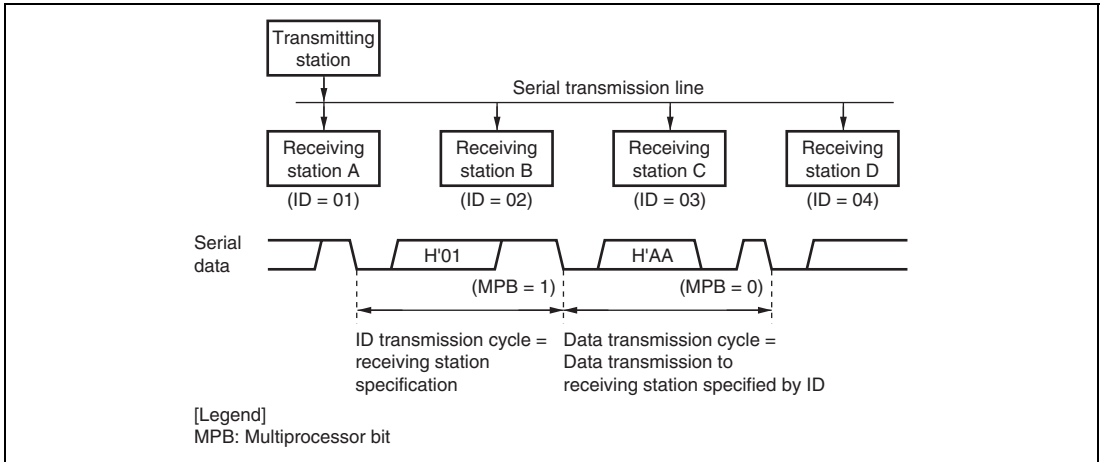

**Figure 14.15 Example of Communication Using Multiprocessor Format
(Transmission of Data H'AA to Receiving Station A)**

14.6.1 Multiprocessor Serial Data Transmission

Figure 14.16 shows a sample flowchart for multiprocessor serial data transmission. For an ID transmission cycle, set the MPBT bit in SSR to 1 before transmission. For a data transmission cycle, clear the MPBT bit in SSR to 0 before transmission. All other SCI3 operations are the same as those in asynchronous mode.

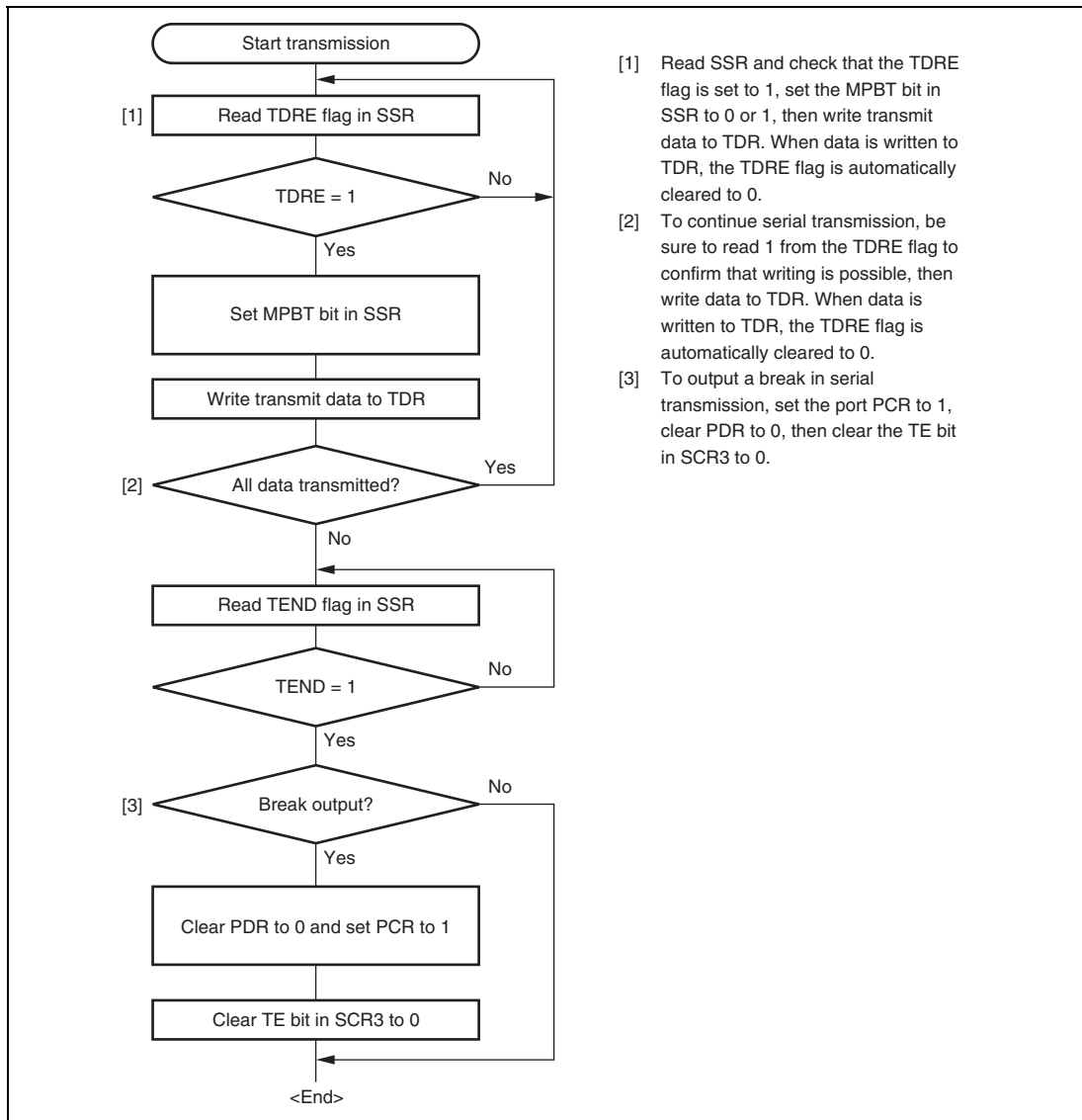
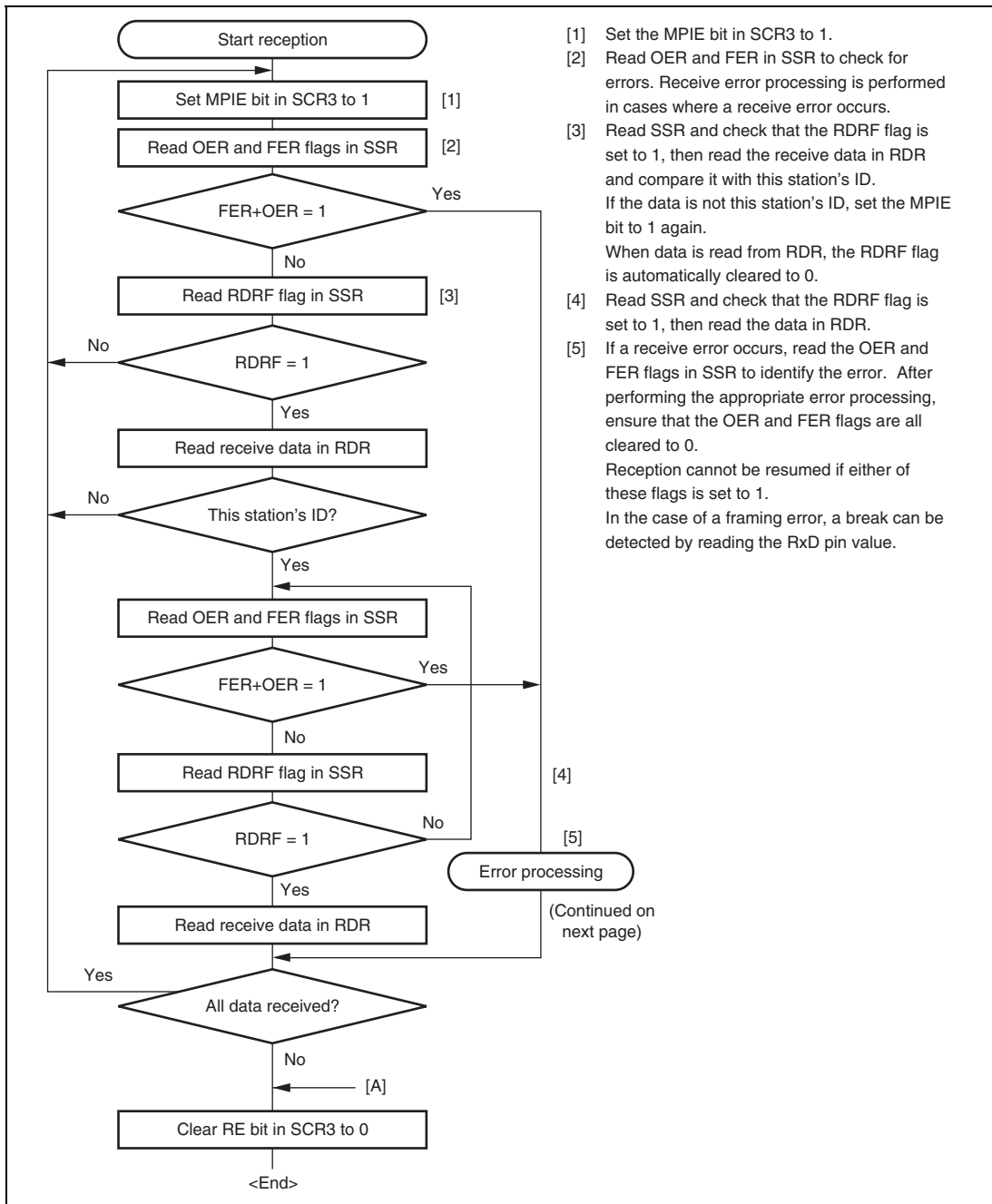

Figure 14.16 Sample Multiprocessor Serial Transmission Flowchart

14.6.2 Multiprocessor Serial Data Reception

Figure 14.17 shows a sample flowchart for multiprocessor serial data reception. If the MPIE bit in SCR3 is set to 1, data is skipped until data with a 1 multiprocessor bit is received. On receiving data with a 1 multiprocessor bit, the receive data is transferred to RDR. An RXI interrupt request is generated at this time. All other SCI3 operations are the same as in asynchronous mode. Figure 14.18 shows an example of SCI3 operation for multiprocessor format reception.



- [1] Set the MPIE bit in SCR3 to 1.
- [2] Read OER and FER in SSR to check for errors. Receive error processing is performed in cases where a receive error occurs.
- [3] Read SSR and check that the RDRF flag is set to 1, then read the receive data in RDR and compare it with this station's ID. If the data is not this station's ID, set the MPIE bit to 1 again. When data is read from RDR, the RDRF flag is automatically cleared to 0.
- [4] Read SSR and check that the RDRF flag is set to 1, then read the data in RDR.
- [5] If a receive error occurs, read the OER and FER flags in SSR to identify the error. After performing the appropriate error processing, ensure that the OER and FER flags are all cleared to 0. Reception cannot be resumed if either of these flags is set to 1. In the case of a framing error, a break can be detected by reading the RxD pin value.

Figure 14.17 Sample Multiprocessor Serial Reception Flowchart (1)

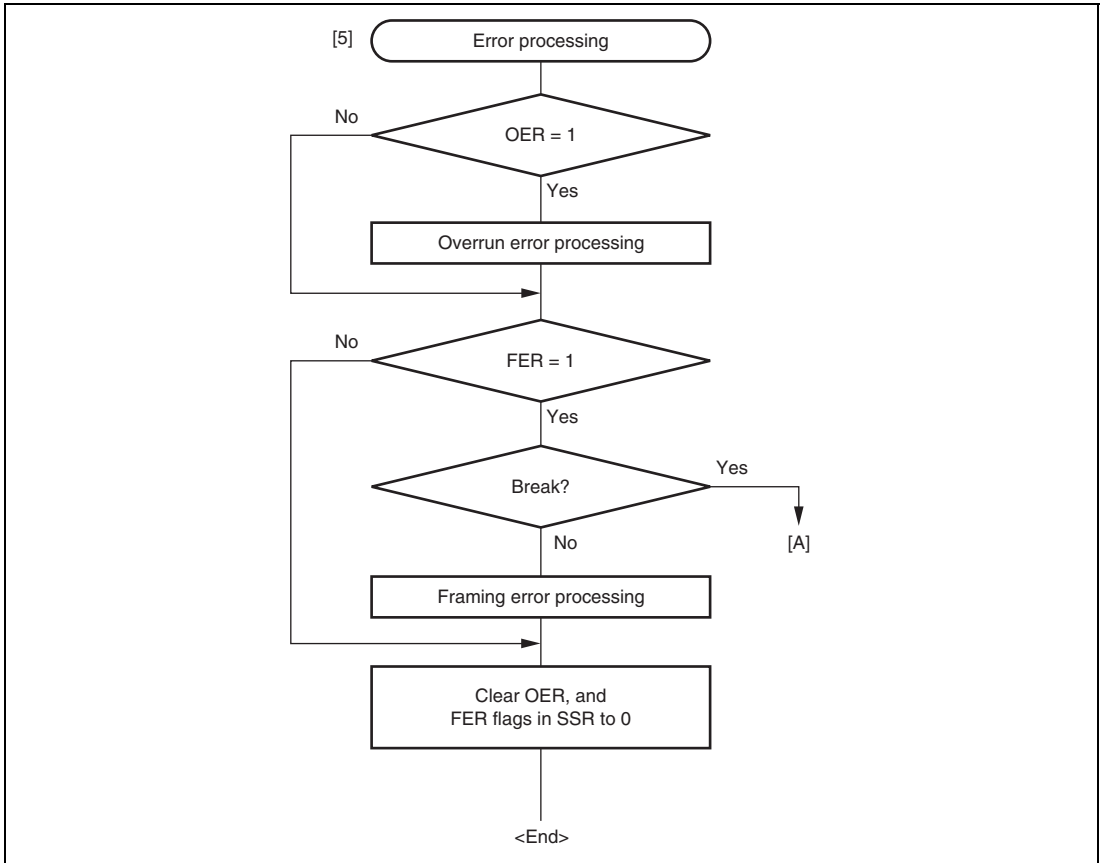

Figure 14.17 Sample Multiprocessor Serial Reception Flowchart (2)

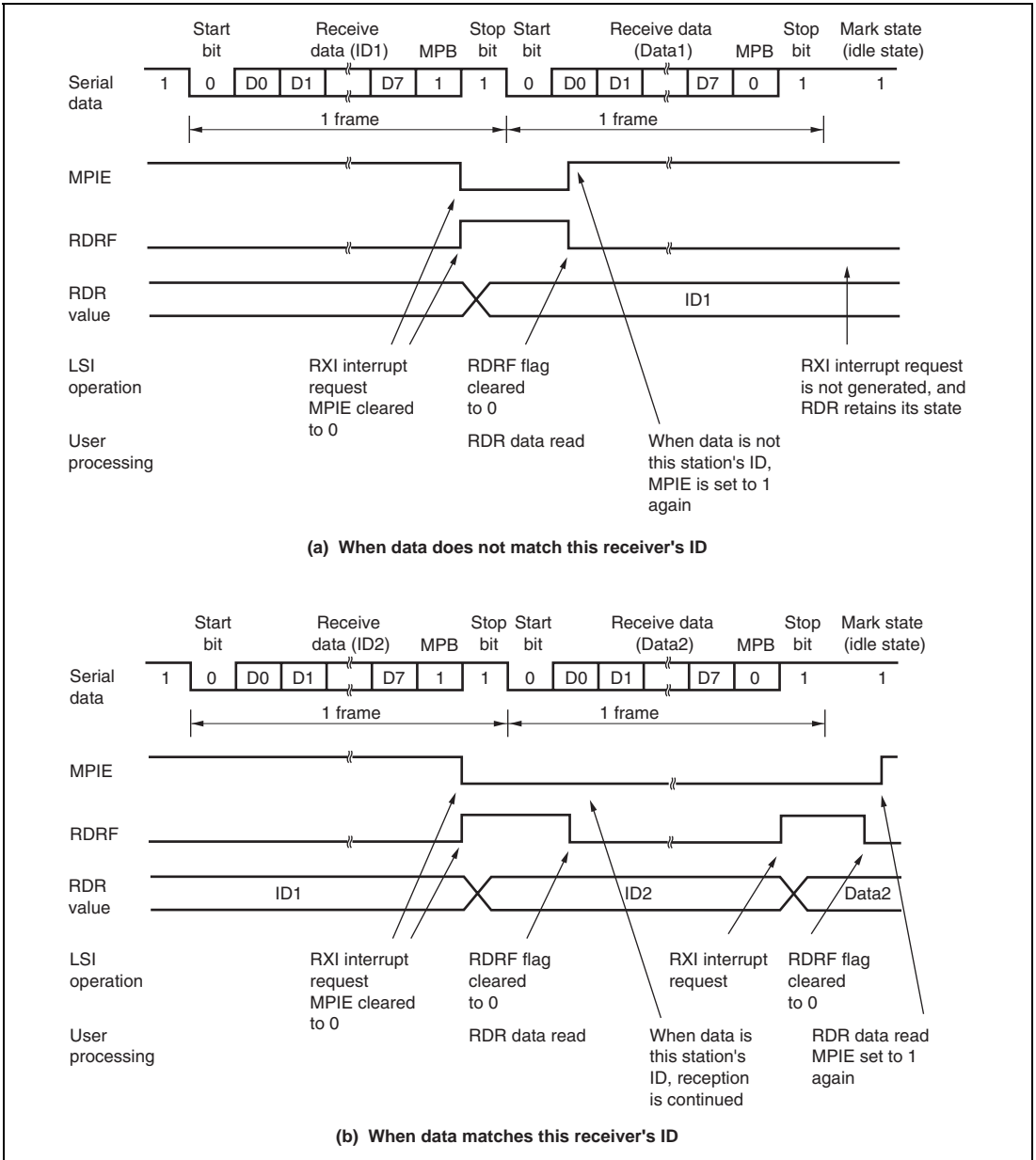

Figure 14.18 Example of SCI3 Operation in Reception Using Multiprocessor Format (Example with 8-Bit Data, Multiprocessor Bit, One Stop Bit)

14.7 Interrupts

The SCI3 creates the following six interrupt requests: transmission end, transmit data empty, receive data full, and receive errors (overrun error, framing error, and parity error). Table 14.6 shows the interrupt sources.

Table 14.6 SCI3 Interrupt Requests

| Interrupt Requests | Abbreviation | Interrupt Sources |
|---------------------------|---------------------|----------------------------------|
| Receive Data Full | RXI | Setting RDRF in SSR |
| Transmit Data Empty | TXI | Setting TDRE in SSR |
| Transmission End | TEI | Setting TEND in SSR |
| Receive Error | ERI | Setting OER, FER, and PER in SSR |

The initial value of the TDRE flag in SSR is 1. Thus, when the TIE bit in SCR3 is set to 1 before transferring the transmit data to TDR, a TXI interrupt request is generated even if the transmit data is not ready. The initial value of the TEND flag in SSR is 1. Thus, when the TEIE bit in SCR3 is set to 1 before transferring the transmit data to TDR, a TEI interrupt request is generated even if the transmit data has not been sent. It is possible to make use of the most of these interrupt requests efficiently by transferring the transmit data to TDR in the interrupt routine. To prevent the generation of these interrupt requests (TXI and TEI), set the enable bits (TIE and TEIE) that correspond to these interrupt requests to 1, after transferring the transmit data to TDR.

14.8 Usage Notes

14.8.1 Break Detection and Processing

When framing error detection is performed, a break can be detected by reading the RxD pin value directly. In a break, the input from the RxD pin becomes all 0, setting the FER flag, and possibly the PER flag. Note that as the SCI3 continues the receive operation after receiving a break, even if the FER flag is cleared to 0, it will be set to 1 again.

14.8.2 Mark State and Break Sending

When TE is 0, the TxD pin is used as an I/O port whose direction (input or output) and level are determined by PCR and PDR. This can be used to set the TxD pin to mark state (high level) or send a break during serial data transmission. To maintain the communication line at mark state until TE is set to 1, set both PCR and PDR to 1. As TE is cleared to 0 at this point, the TxD pin becomes an I/O port, and 1 is output from the TxD pin. To send a break during serial transmission, first set PCR to 1 and PDR to 0, and then clear TE to 0. When TE is cleared to 0, the transmitter is initialized regardless of the current transmission state, the TxD pin becomes an I/O port, and 0 is output from the TxD pin.

14.8.3 Receive Error Flags and Transmit Operations (Clocked Synchronous Mode Only)

Transmission cannot be started when a receive error flag (OER, PER, or FER) is set to 1, even if the TDRE flag is cleared to 0. Be sure to clear the receive error flags to 0 before starting transmission. Note also that receive error flags cannot be cleared to 0 even if the RE bit is cleared to 0.

14.8.4 Receive Data Sampling Timing and Reception Margin in Asynchronous Mode

In asynchronous mode, the SCI3 operates on a basic clock with a frequency of 16 times the transfer rate. In reception, the SCI3 samples the falling edge of the start bit using the basic clock, and performs internal synchronization. Receive data is latched internally at the rising edge of the 8th pulse of the basic clock as shown in figure 14.19.

Thus, the reception margin in asynchronous mode is given by formula (1) below.

$$M = \left\{ \left(0.5 - \frac{1}{2N} \right) - \frac{D - 0.5}{N} - (L - 0.5) F \right\} \times 100(\%)$$

... Formula (1)

Where N : Ratio of bit rate to clock (N = 16)
 D : Clock duty (D = 0.5 to 1.0)
 L : Frame length (L = 9 to 12)
 F : Absolute value of clock rate deviation

Assuming values of F (absolute value of clock rate deviation) = 0 and D (clock duty) = 0.5 in formula (1), the reception margin can be given by the formula.

$$M = \{ 0.5 - 1/(2 \times 16) \} \times 100 [\%] = 46.875\%$$

However, this is only the computed value, and a margin of 20% to 30% should be allowed for in system design.

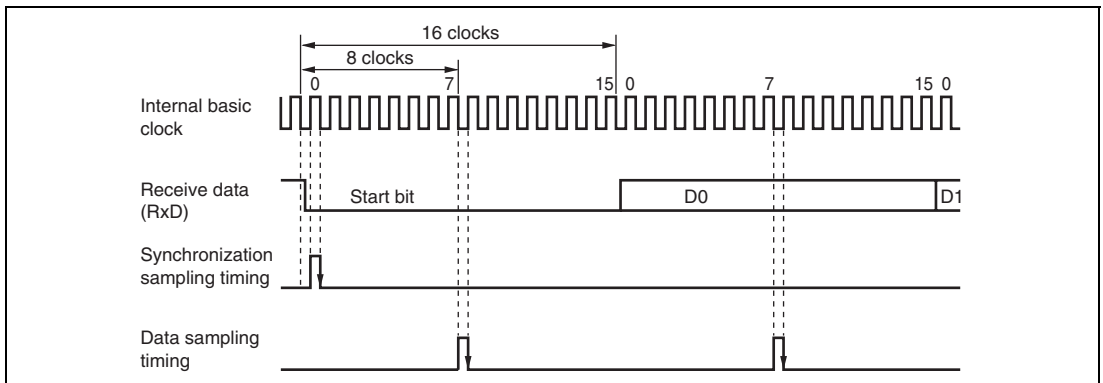

Figure 14.19 Receive Data Sampling Timing in Asynchronous Mode

Section 15 I²C Bus Interface 2 (IIC2)

The I²C bus interface 2 conforms to and provides a subset of the Philips I²C bus (inter-IC bus) interface functions. The register configuration that controls the I²C bus differs partly from the Philips configuration, however.

Figure 15.1 shows a block diagram of the I²C bus interface 2.

Figure 15.2 shows an example of I/O pin connections to external circuits.

15.1 Features

- Selection of I²C format or clocked synchronous serial format
- Continuous transmission/reception
Since the shift register, transmit data register, and receive data register are independent from each other, the continuous transmission/reception can be performed.

I²C bus format

- Start and stop conditions generated automatically in master mode
- Selection of acknowledge output levels when receiving
- Automatic loading of acknowledge bit when transmitting
- Bit synchronization/wait function

In master mode, the state of SCL is monitored per bit, and the timing is synchronized automatically.

If transmission/reception is not yet possible, set the SCL to low until preparations are completed.

- Six interrupt sources
Transmit data empty (including slave-address match), transmit end, receive data full (including slave-address match), arbitration lost, NACK detection, and stop condition detection
- Direct bus drive
Two pins, SCL and SDA pins, function as NMOS open-drain outputs when the bus drive function is selected.

Clocked synchronous format

- Four interrupt sources
Transmit-data-empty, transmit-end, receive-data-full, and overrun error

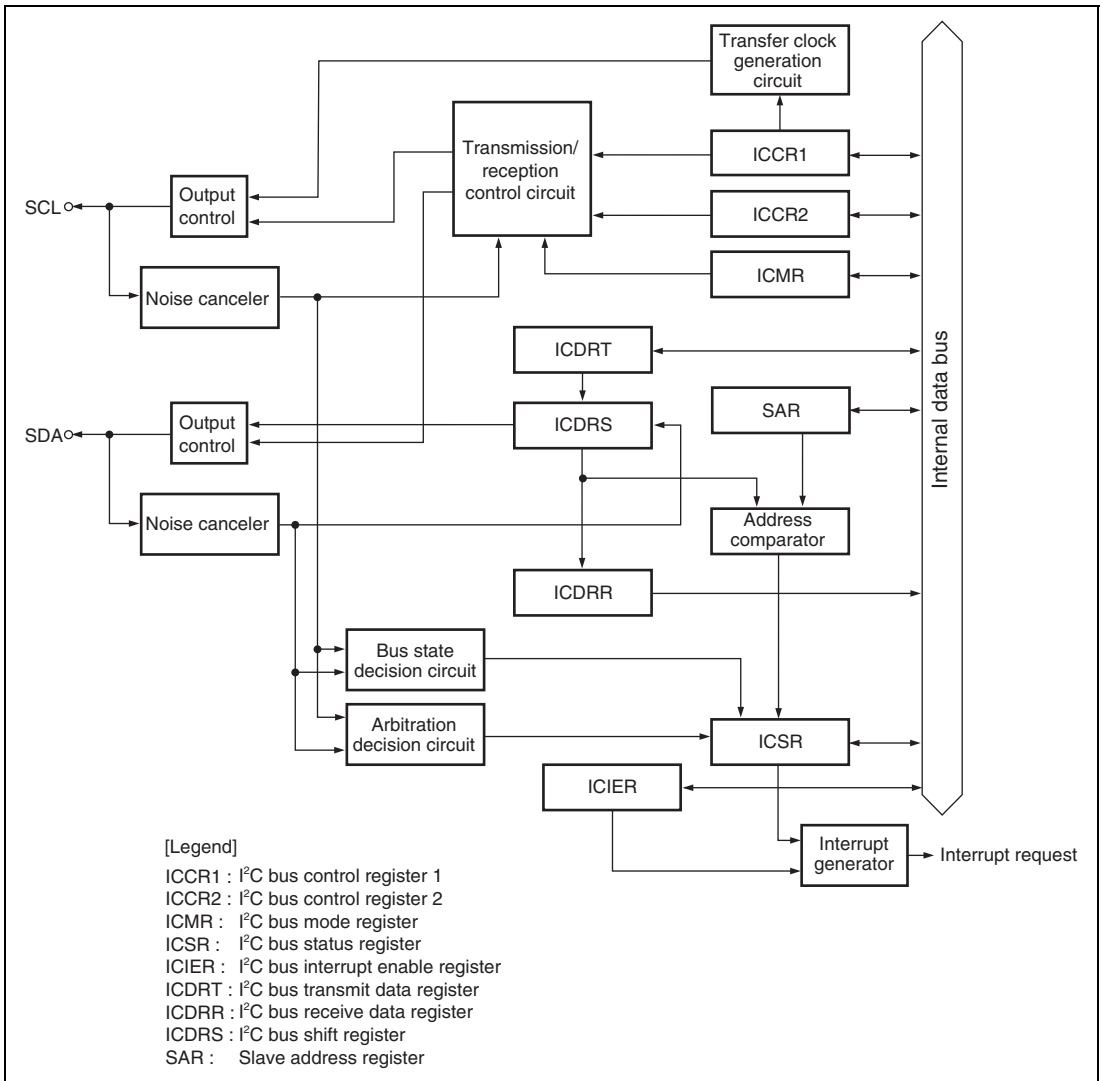

Figure 15.1 Block Diagram of I²C Bus Interface 2

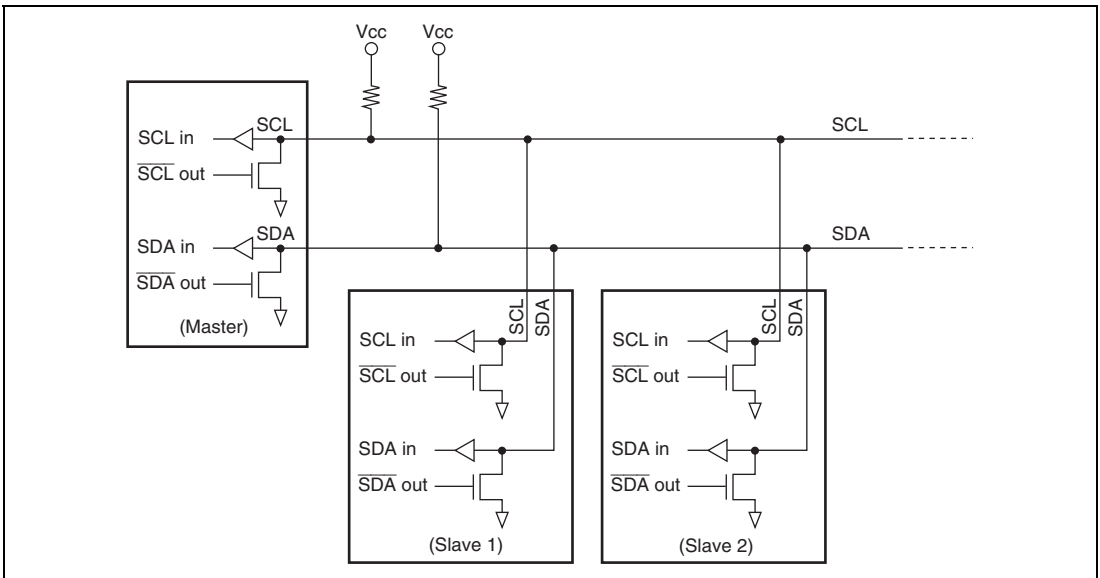

Figure 15.2 External Circuit Connections of I/O Pins

15.2 Input/Output Pins

Table 15.1 summarizes the input/output pins used by the I²C bus interface 2.

Table 15.1 I²C Bus Interface Pins

| Name | Abbreviation | I/O | Function |
|--------------|--------------|-----|-------------------------------|
| Serial clock | SCL | I/O | IIC serial clock input/output |
| Serial data | SDA | I/O | IIC serial data input/output |

15.3 Register Descriptions

The I²C bus interface 2 has the following registers:

- I²C bus control register 1 (ICCR1)
- I²C bus control register 2 (ICCR2)
- I²C bus mode register (ICMR)
- I²C bus interrupt enable register (ICIER)
- I²C bus status register (ICSR)
- I²C bus slave address register (SAR)

- I²C bus transmit data register (ICDRT)
- I²C bus receive data register (ICDRR)
- I²C bus shift register (ICDRS)

15.3.1 I²C Bus Control Register 1 (ICCR1)

ICCR1 enables or disables the I²C bus interface 2, controls transmission or reception, and selects master or slave mode, transmission or reception, and transfer clock frequency in master mode.

| Bit | Bit Name | Initial Value | R/W | Description |
|-----|----------|---------------|-----|--|
| 7 | ICE | 0 | R/W | <p>I²C Bus Interface Enable</p> <p>0: This module is halted. (SCL and SDA pins are set to port function.)</p> <p>1: This bit is enabled for transfer operations. (SCL and SDA pins are bus drive state.)</p> |
| 6 | RCVD | 0 | R/W | <p>Reception Disable</p> <p>This bit enables or disables the next operation when TRS is 0 and ICDRR is read.</p> <p>0: Enables next reception</p> <p>1: Disables next reception</p> |
| 5 | MST | 0 | R/W | Master/Slave Select |
| 4 | TRS | 0 | R/W | <p>Transmit/Receive Select</p> <p>In master mode with the I²C bus format, when arbitration is lost, MST and TRS are both reset by hardware, causing a transition to slave receive mode. Modification of the TRS bit should be made between transfer frames.</p> <p>After data receive has been started in slave receive mode, when the first seven bits of the receive data agree with the slave address that is set to SAR and the eighth bit is 1, TRS is automatically set to 1. If an overrun error occurs in master mode with the clock synchronous serial format, MST is cleared to 0 and slave receive mode is entered.</p> <p>Operating modes are described below according to MST and TRS combination. When clocked synchronous serial format is selected and MST is 1, clock is output.</p> <p>00: Slave receive mode</p> <p>01: Slave transmit mode</p> <p>10: Master receive mode</p> <p>11: Master transmit mode</p> |

| Bit | Bit Name | Initial Value | R/W | Description |
|-----|----------|---------------|-----|--|
| 3 | CKS3 | 0 | R/W | Transfer Clock Select 3 to 0 |
| 2 | CKS2 | 0 | R/W | These bits should be set according to the necessary transfer rate (see table 15.2) in master mode. In slave mode, these bits are used for reservation of the setup time in transmit mode. The time is 10 t _{cyc} when CKS3 = 0 and 20 t _{cyc} when CKS3 = 1. |
| 1 | CKS1 | 0 | R/W | |
| 0 | CKS0 | 0 | R/W | |

Table 15.2 Transfer Rate

| Bit 3 | Bit 2 | Bit 1 | Bit 0 | Clock | Transfer Rate | | | | | |
|-------|-------|-------|-------|-------|---------------|-----------|------------|------------|------------|----------|
| | | | | | φ = 5 MHz | φ = 8 MHz | φ = 10 MHz | φ = 16 MHz | φ = 20 MHz | |
| 0 | 0 | 0 | 0 | φ/28 | 179 kHz | 286 kHz | 357 kHz | 571 kHz | 714 kHz | |
| | | | 1 | φ/40 | 125 kHz | 200 kHz | 250 kHz | 400 kHz | 500 kHz | |
| | | 1 | 0 | φ/48 | 104 kHz | 167 kHz | 208 kHz | 333 kHz | 417 kHz | |
| | | | 1 | φ/64 | 78.1 kHz | 125 kHz | 156 kHz | 250 kHz | 313 kHz | |
| | 1 | 0 | 0 | φ/80 | 62.5 kHz | 100 kHz | 125 kHz | 200 kHz | 250 kHz | |
| | | | 1 | φ/100 | 50.0 kHz | 80.0 kHz | 100 kHz | 160 kHz | 200 kHz | |
| | | | 1 | φ/112 | 44.6 kHz | 71.4 kHz | 89.3 kHz | 143 kHz | 179 kHz | |
| | | 1 | 0 | φ/128 | 39.1 kHz | 62.5 kHz | 78.1 kHz | 125 kHz | 156 kHz | |
| | | | 1 | 0 | φ/56 | 89.3 kHz | 143 kHz | 179 kHz | 286 kHz | 357 kHz |
| | | | | 1 | φ/80 | 62.5 kHz | 100 kHz | 125 kHz | 200 kHz | 250 kHz |
| 1 | 0 | 0 | 0 | φ/96 | 52.1 kHz | 83.3 kHz | 104 kHz | 167 kHz | 208 kHz | |
| | | | 1 | φ/128 | 39.1 kHz | 62.5 kHz | 78.1 kHz | 125 kHz | 156 kHz | |
| | | 1 | 0 | φ/160 | 31.3 kHz | 50.0 kHz | 62.5 kHz | 100 kHz | 125 kHz | |
| | | | 1 | φ/200 | 25.0 kHz | 40.0 kHz | 50.0 kHz | 80.0 kHz | 100 kHz | |
| | 1 | 0 | 0 | φ/224 | 22.3 kHz | 35.7 kHz | 44.6 kHz | 71.4 kHz | 89.3 kHz | |
| | | | 1 | 0 | φ/256 | 19.5 kHz | 31.3 kHz | 39.1 kHz | 62.5 kHz | 78.1 kHz |
| | | | | 1 | φ/256 | 19.5 kHz | 31.3 kHz | 39.1 kHz | 62.5 kHz | 78.1 kHz |

15.3.2 I²C Bus Control Register 2 (ICCR2)

ICCR1 issues start/stop conditions, manipulates the SDA pin, monitors the SCL pin, and controls reset in the control part of the I²C bus interface 2.

| Bit | Bit Name | Initial Value | R/W | Description |
|-----|----------|---------------|-----|---|
| 7 | BBSY | 0 | R/W | <p>Bus Busy</p> <p>This bit enables to confirm whether the I²C bus is occupied or released and to issue start/stop conditions in master mode. With the clocked synchronous serial format, this bit has no meaning. With the I²C bus format, this bit is set to 1 when the SDA level changes from high to low under the condition of SCL = high, assuming that the start condition has been issued. This bit is cleared to 0 when the SDA level changes from low to high under the condition of SCL = high, assuming that the stop condition has been issued. Write 1 to BBSY and 0 to SCP to issue a start condition. Follow this procedure when also re-transmitting a start condition. Write 0 in BBSY and 0 in SCP to issue a stop condition. To issue start/stop conditions, use the MOV instruction.</p> |
| 6 | SCP | 1 | W | <p>Start/Stop Issue Condition Disable</p> <p>The SCP bit controls the issue of start/stop conditions in master mode.</p> <p>To issue a start condition, write 1 in BBSY and 0 in SCP. A retransmit start condition is issued in the same way. To issue a stop condition, write 0 in BBSY and 0 in SCP. This bit is always read as 1. If 1 is written, the data is not stored.</p> |
| 5 | SDAO | 1 | R/W | <p>SDA Output Value Control</p> <p>This bit is used with SDAOP when modifying output level of SDA. This bit should not be manipulated during transfer.</p> <p>0: When reading, SDA pin outputs low. When writing, SDA pin is changed to output low.</p> <p>1: When reading, SDA pin outputs high. When writing, SDA pin is changed to output Hi-Z (outputs high by external pull-up resistance).</p> |

| Bit | Bit Name | Initial Value | R/W | Description |
|-----|----------|---------------|-----|--|
| 4 | SDAOP | 1 | R/W | SDAO Write Protect This bit controls change of output level of the SDA pin by modifying the SDAO bit. To change the output level, clear SDAO and SDAOP to 0 or set SDAO to 1 and clear SDAOP to 0 by the MOV instruction. This bit is always read as 1. |
| 3 | SCLO | 1 | R | This bit monitors SCL output level. When SCLO is 1, SCL pin outputs high. When SCLO is 0, SCL pin outputs low. |
| 2 | — | 1 | — | Reserved This bit is always read as 1, and cannot be modified. |
| 1 | IICRST | 0 | R/W | IIC Control Part Reset This bit resets the control part except for I ² C registers. If this bit is set to 1 when hang-up occurs because of communication failure during I ² C operation, I ² C control part can be reset without setting ports and initializing registers. |
| 0 | — | 1 | — | Reserved This bit is always read as 1, and cannot be modified. |

15.3.3 I²C Bus Mode Register (ICMR)

ICMR selects whether the MSB or LSB is transferred first, performs master mode wait control, and selects the transfer bit count.

| Bit | Bit Name | Initial Value | R/W | Description |
|-----|----------|---------------|-----|---|
| 7 | MLS | 0 | R/W | MSB-First/LSB-First Select 0: MSB-first 1: LSB-first Set this bit to 0 when the I ² C bus format is used. |
| 6 | WAIT | 0 | R/W | Wait Insertion Bit In master mode with the I ² C bus format, this bit selects whether to insert a wait after data transfer except the acknowledge bit. When WAIT is set to 1, after the fall of the clock for the final data bit, low period is extended for two transfer clocks. If WAIT is cleared to 0, data and acknowledge bits are transferred consecutively with no wait inserted. The setting of this bit is invalid in slave mode with the I ² C bus format or with the clocked synchronous serial format. |

| Bit | Bit Name | Initial Value | R/W | Description | | | | | | | | | | | | | | | | | | |
|-----------------------------|---------------------------------|---------------|-----|---|-----------------------------|---------------------------------|-------------|-------------|-------------|-------------|-------------|-------------|-------------|-------------|-------------|-------------|-------------|-------------|-------------|-------------|-------------|-------------|
| 5, 4 | — | All 1 | — | Reserved These bits are always read as 1, and cannot be modified. | | | | | | | | | | | | | | | | | | |
| 3 | BCWP | 1 | R/W | BC Write Protect This bit controls the BC2 to BC0 modifications. When modifying BC2 to BC0, this bit should be cleared to 0 and use the MOV instruction. In clock synchronous serial mode, BC should not be modified. 0: When writing, values of BC2 to BC0 are set. 1: When reading, 1 is always read. When writing, settings of BC2 to BC0 are invalid. | | | | | | | | | | | | | | | | | | |
| 2 | BC2 | 0 | R/W | Bit Counter 2 to 0 | | | | | | | | | | | | | | | | | | |
| 1 | BC1 | 0 | R/W | These bits specify the number of bits to be transferred next. When read, the remaining number of transfer bits is indicated. With the I ² C bus format, the data is transferred with one addition acknowledge bit. Bit BC2 to BC0 settings should be made during an interval between transfer frames. If bits BC2 to BC0 are set to a value other than 000, the setting should be made while the SCL pin is low. The value returns to 000 at the end of a data transfer, including the acknowledge bit. With the clock synchronous serial format, these bits should not be modified. | | | | | | | | | | | | | | | | | | |
| 0 | BC0 | 0 | R/W | | | | | | | | | | | | | | | | | | | |
| | | | | <table> <thead> <tr> <th>I²C Bus Format</th> <th>Clock Synchronous Serial Format</th> </tr> </thead> <tbody> <tr> <td>000: 9 bits</td> <td>000: 8 bits</td> </tr> <tr> <td>001: 2 bits</td> <td>001: 1 bits</td> </tr> <tr> <td>010: 3 bits</td> <td>010: 2 bits</td> </tr> <tr> <td>011: 4 bits</td> <td>011: 3 bits</td> </tr> <tr> <td>100: 5 bits</td> <td>100: 4 bits</td> </tr> <tr> <td>101: 6 bits</td> <td>101: 5 bits</td> </tr> <tr> <td>110: 7 bits</td> <td>110: 6 bits</td> </tr> <tr> <td>111: 8 bits</td> <td>111: 7 bits</td> </tr> </tbody> </table> | I ² C Bus Format | Clock Synchronous Serial Format | 000: 9 bits | 000: 8 bits | 001: 2 bits | 001: 1 bits | 010: 3 bits | 010: 2 bits | 011: 4 bits | 011: 3 bits | 100: 5 bits | 100: 4 bits | 101: 6 bits | 101: 5 bits | 110: 7 bits | 110: 6 bits | 111: 8 bits | 111: 7 bits |
| I ² C Bus Format | Clock Synchronous Serial Format | | | | | | | | | | | | | | | | | | | | | |
| 000: 9 bits | 000: 8 bits | | | | | | | | | | | | | | | | | | | | | |
| 001: 2 bits | 001: 1 bits | | | | | | | | | | | | | | | | | | | | | |
| 010: 3 bits | 010: 2 bits | | | | | | | | | | | | | | | | | | | | | |
| 011: 4 bits | 011: 3 bits | | | | | | | | | | | | | | | | | | | | | |
| 100: 5 bits | 100: 4 bits | | | | | | | | | | | | | | | | | | | | | |
| 101: 6 bits | 101: 5 bits | | | | | | | | | | | | | | | | | | | | | |
| 110: 7 bits | 110: 6 bits | | | | | | | | | | | | | | | | | | | | | |
| 111: 8 bits | 111: 7 bits | | | | | | | | | | | | | | | | | | | | | |

15.3.4 I²C Bus Interrupt Enable Register (ICIER)

ICIER enables or disables interrupt sources and acknowledge bits, sets acknowledge bits to be transferred, and confirms acknowledge bits to be received.

| Bit | Bit Name | Initial Value | R/W | Description |
|-----|----------|---------------|-----|--|
| 7 | TIE | 0 | R/W | <p>Transmit Interrupt Enable</p> <p>When the TDRE bit in ICSR is set to 1, this bit enables or disables the transmit data empty interrupt (TXI).</p> <p>0: Transmit data empty interrupt request (TXI) is disabled.</p> <p>1: Transmit data empty interrupt request (TXI) is enabled.</p> |
| 6 | TEIE | 0 | R/W | <p>Transmit End Interrupt Enable</p> <p>This bit enables or disables the transmit end interrupt (TEI) at the rising of the ninth clock while the TDRE bit in ICSR is 1. TEI can be canceled by clearing the TEND bit or the TEIE bit to 0.</p> <p>0: Transmit end interrupt request (TEI) is disabled.</p> <p>1: Transmit end interrupt request (TEI) is enabled.</p> |
| 5 | RIE | 0 | R/W | <p>Receive Interrupt Enable</p> <p>This bit enables or disables the receive data full interrupt request (RXI) and the overrun error interrupt request (ERI) with the clocked synchronous format, when a receive data is transferred from ICDRS to ICDRR and the RDRF bit in ICSR is set to 1. RXI can be canceled by clearing the RDRF or RIE bit to 0.</p> <p>0: Receive data full interrupt request (RXI) and overrun error interrupt request (ERI) with the clocked synchronous format are disabled.</p> <p>1: Receive data full interrupt request (RXI) and overrun error interrupt request (ERI) with the clocked synchronous format are enabled.</p> |
| 4 | NAKIE | 0 | R/W | <p>NACK Receive Interrupt Enable</p> <p>This bit enables or disables the NACK receive interrupt request (NAKI) and the overrun error (setting of the OVE bit in ICSR) interrupt request (ERI) with the clocked synchronous format, when the NACKF and AL bits in ICSR are set to 1. NAKI can be canceled by clearing the NACKF, OVE, or NAKIE bit to 0.</p> <p>0: NACK receive interrupt request (NAKI) is disabled.</p> <p>1: NACK receive interrupt request (NAKI) is enabled.</p> |

| Bit | Bit Name | Initial Value | R/W | Description |
|-----|----------|---------------|-----|--|
| 3 | STIE | 0 | R/W | <p>Stop Condition Detection Interrupt Enable</p> <p>0: Stop condition detection interrupt request (STPI) is disabled.</p> <p>1: Stop condition detection interrupt request (STPI) is enabled.</p> |
| 2 | ACKE | 0 | R/W | <p>Acknowledge Bit Judgement Select</p> <p>0: The value of the receive acknowledge bit is ignored, and continuous transfer is performed.</p> <p>1: If the receive acknowledge bit is 1, continuous transfer is halted.</p> |
| 1 | ACKBR | 0 | R | <p>Receive Acknowledge</p> <p>In transmit mode, this bit stores the acknowledge data that are returned by the receive device. This bit cannot be modified.</p> <p>0: Receive acknowledge = 0</p> <p>1: Receive acknowledge = 1</p> |
| 0 | ACKBT | 0 | R/W | <p>Transmit Acknowledge</p> <p>In receive mode, this bit specifies the bit to be sent at the acknowledge timing.</p> <p>0: 0 is sent at the acknowledge timing.</p> <p>1: 1 is sent at the acknowledge timing.</p> |

15.3.5 I²C Bus Status Register (ICSR)

ICSR performs confirmation of interrupt request flags and status.

| Bit | Bit Name | Initial Value | R/W | Description |
|-----|----------|---------------|-----|---|
| 7 | TDRE | 0 | R/W | Transmit Data Register Empty [Setting conditions] <ul style="list-style-type: none"> • When data is transferred from ICDRT to ICDRS and ICDRT becomes empty • When TRS is set • When a start condition (including re-transfer) has been issued • When transmit mode is entered from receive mode in slave mode [Clearing conditions] <ul style="list-style-type: none"> • When 0 is written in TDRE after reading TDRE = 1 • When data is written to ICDRT with an instruction |
| 6 | TEND | 0 | R/W | Transmit End [Setting conditions] <ul style="list-style-type: none"> • When the ninth clock of SCL rises with the I²C bus format while the TDRE flag is 1 • When the final bit of transmit frame is sent with the clock synchronous serial format [Clearing conditions] <ul style="list-style-type: none"> • When 0 is written in TEND after reading TEND = 1 • When data is written to ICDRT with an instruction |
| 5 | RDRF | 0 | R/W | Receive Data Register Full [Setting condition] <ul style="list-style-type: none"> • When a receive data is transferred from ICDRS to ICDRR [Clearing conditions] <ul style="list-style-type: none"> • When 0 is written in RDRF after reading RDRF = 1 • When ICDRR is read with an instruction |

| Bit | Bit Name | Initial Value | R/W | Description |
|-----|----------|---------------|-----|---|
| 4 | NACKF | 0 | R/W | <p>No Acknowledge Detection Flag</p> <p>[Setting condition]</p> <ul style="list-style-type: none">When no acknowledge is detected from the receive device in transmission while the ACKE bit in ICIER is 1 <p>[Clearing condition]</p> <ul style="list-style-type: none">When 0 is written in NACKF after reading NACKF = 1 |
| 3 | STOP | 0 | R/W | <p>Stop Condition Detection Flag</p> <p>[Setting conditions]</p> <ul style="list-style-type: none">In master mode, when a stop condition is detected after frame transferIn slave mode, when a stop condition is detected after the general call address or the first byte slave address, next to detection of start condition, accords with the address set in SAR <p>[Clearing condition]</p> <ul style="list-style-type: none">When 0 is written in STOP after reading STOP = 1 |

| Bit | Bit Name | Initial Value | R/W | Description |
|-----|----------|---------------|-----|---|
| 2 | AL/OVE | 0 | R/W | <p>Arbitration Lost Flag/Overrun Error Flag</p> <p>This flag indicates that arbitration was lost in master mode with the I²C bus format and that the final bit has been received while RDRF = 1 with the clocked synchronous format.</p> <p>When two or more master devices attempt to seize the bus at nearly the same time, if the I²C bus interface detects data differing from the data it sent, it sets AL to 1 to indicate that the bus has been taken by another master.</p> <p>[Setting conditions]</p> <ul style="list-style-type: none"> • If the internal SDA and SDA pin disagree at the rise of SCL in master transmit mode • When the SDA pin outputs high in master mode while a start condition is detected • When the final bit is received with the clocked synchronous format while RDRF = 1 <p>[Clearing condition]</p> <ul style="list-style-type: none"> • When 0 is written in AL/OVE after reading AL/OVE = 1 |
| 1 | AAS | 0 | R/W | <p>Slave Address Recognition Flag</p> <p>In slave receive mode, this flag is set to 1 if the first frame following a start condition matches bits SVA6 to SVA0 in SAR.</p> <p>[Setting conditions]</p> <ul style="list-style-type: none"> • When the slave address is detected in slave receive mode • When the general call address is detected in slave receive mode. <p>[Clearing condition]</p> <ul style="list-style-type: none"> • When 0 is written in AAS after reading AAS = 1 |
| 0 | ADZ | 0 | R/W | <p>General Call Address Recognition Flag</p> <p>This bit is valid in I²C bus format slave receive mode.</p> <p>[Setting condition]</p> <ul style="list-style-type: none"> • When the general call address is detected in slave receive mode <p>[Clearing condition]</p> <ul style="list-style-type: none"> • When 0 is written in ADZ after reading ADZ = 1 |

15.3.6 Slave Address Register (SAR)

SAR selects the communication format and sets the slave address. When the chip is in slave mode with the I²C bus format, if the upper 7 bits of SAR match the upper 7 bits of the first frame received after a start condition, the chip operates as the slave device.

| Bit | Bit Name | Initial Value | R/W | Description |
|--------|--------------|---------------|-----|--|
| 7 to 1 | SVA6 to SVA0 | All 0 | R/W | Slave Address 6 to 0 These bits set a unique address in bits SVA6 to SVA0, differing from the addresses of other slave devices connected to the I ² C bus. |
| 0 | FS | 0 | R/W | Format Select 0: I ² C bus format is selected. 1: Clocked synchronous serial format is selected. |

15.3.7 I²C Bus Transmit Data Register (ICDRT)

ICDRT is an 8-bit readable/writable register that stores the transmit data. When ICDRT detects the space in the shift register (ICDRS), it transfers the transmit data which is written in ICDRT to ICDRS and starts transferring data. If the next transfer data is written to ICDRT during transferring data of ICDRS, continuous transfer is possible. If the MLS bit of ICMR is set to 1 and when the data is written to ICDRT, the MSB/LSB inverted data is read. The initial value of ICDRT is H'FF. The initial value of ICDRT is H'FF.

15.3.8 I²C Bus Receive Data Register (ICDRR)

ICDRR is an 8-bit register that stores the receive data. When data of one byte is received, ICDRR transfers the receive data from ICDRS to ICDRR and the next data can be received. ICDRR is a receive-only register, therefore the CPU cannot write to this register. The initial value of ICDRR is H'FF.

15.3.9 I²C Bus Shift Register (ICDRS)

ICDRS is a register that is used to transfer/receive data. In transmission, data is transferred from ICDRT to ICDRS and the data is sent from the SDA pin. In reception, data is transferred from ICDRS to ICDRR after data of one byte is received. This register cannot be read directly from the CPU.

15.4 Operation

The I²C bus interface can communicate either in I²C bus mode or clocked synchronous serial mode by setting FS in SAR.

15.4.1 I²C Bus Format

Figure 15.3 shows the I²C bus formats. Figure 15.4 shows the I²C bus timing. The first frame following a start condition always consists of 8 bits.

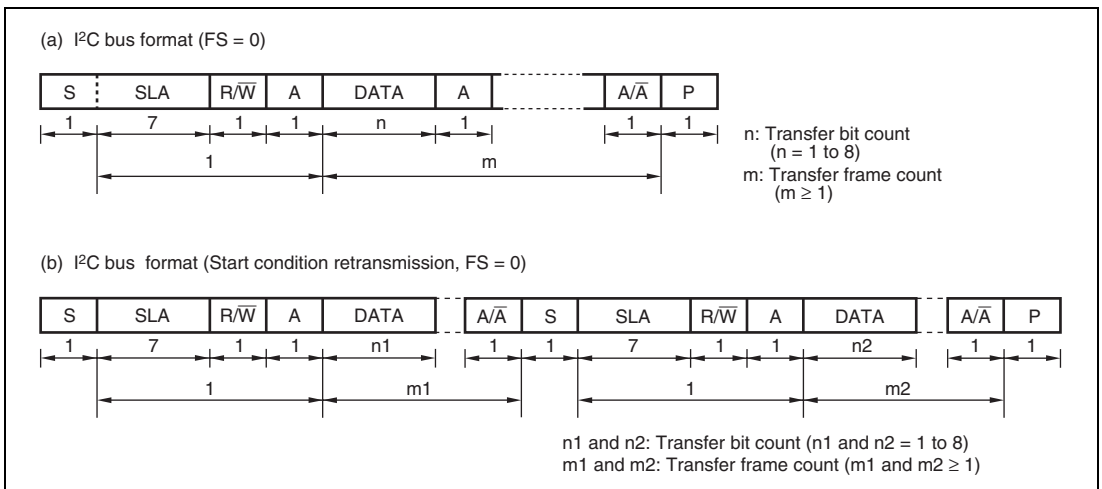

Figure 15.3 I²C Bus Formats

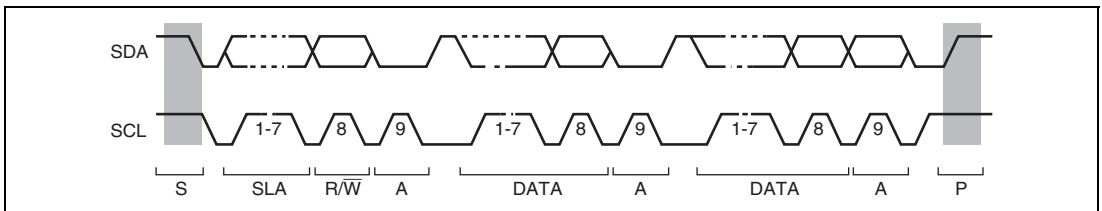

Figure 15.4 I²C Bus Timing

Legend

S: Start condition. The master device drives SDA from high to low while SCL is high.
SLA: Slave address

$\overline{R/\overline{W}}$: Indicates the direction of data transfer: from the slave device to the master device when $\overline{R/\overline{W}}$ is 1, or from the master device to the slave device when $\overline{R/\overline{W}}$ is 0.

A: Acknowledge. The receive device drives SDA to low.

DATA: Transfer data

P: Stop condition. The master device drives SDA from low to high while SCL is high.

15.4.2 Master Transmit Operation

In master transmit mode, the master device outputs the transmit clock and transmit data, and the slave device returns an acknowledge signal. For master transmit mode operation timing, refer to figures 15.5 and 15.6. The transmission procedure and operations in master transmit mode are described below.

1. Set the ICE bit in ICCR1 to 1. Set the MLS and WAIT bits in ICMR and the CKS3 to CKS0 bits in ICCR1 to 1. (Initial setting)
2. Read the BBSY flag in ICCR2 to confirm that the bus is free. Set the MST and TRS bits in ICCR1 to select master transmit mode. Then, write 1 to BBSY and 0 to SCP using MOV instruction. (Start condition issued) This generates the start condition.
3. After confirming that TDRE in ICSR has been set, write the transmit data (the first byte data show the slave address and $\overline{R/\overline{W}}$) to ICDRT. At this time, TDRE is automatically cleared to 0, and data is transferred from ICDRT to ICDRS. TDRE is set again.
4. When transmission of one byte data is completed while TDRE is 1, TEND in ICSR is set to 1 at the rise of the 9th transmit clock pulse. Read the ACKBR bit in ICIER, and confirm that the slave device has been selected. Then, write second byte data to ICDRT. When ACKBR is 1, the slave device has not been acknowledged, so issue the stop condition. To issue the stop condition, write 0 to BBSY and SCP using MOV instruction. SCL is fixed low until the transmit data is prepared or the stop condition is issued.
5. The transmit data after the second byte is written to ICDRT every time TDRE is set.
6. Write the number of bytes to be transmitted to ICDRT. Wait until TEND is set (the end of last byte data transmission) while TDRE is 1, or wait for NACK (NACKF in ICSR = 1) from the receive device while ACKE in ICIER is 1. Then, issue the stop condition to clear TEND or NACKF.
7. When the STOP bit in ICSR is set to 1, the operation returns to the slave receive mode.

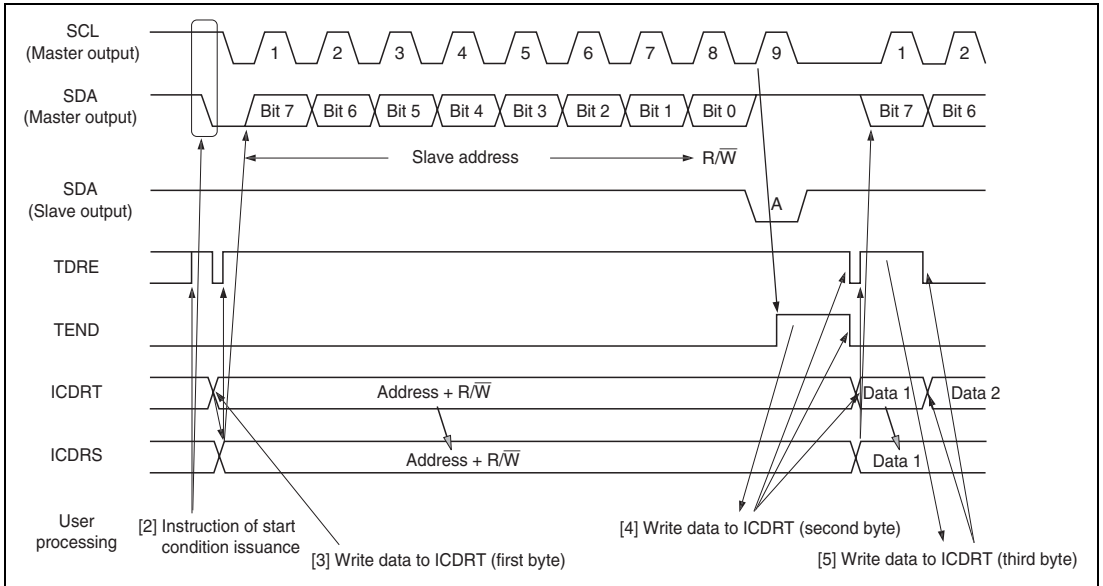

Figure 15.5 Master Transmit Mode Operation Timing (1)

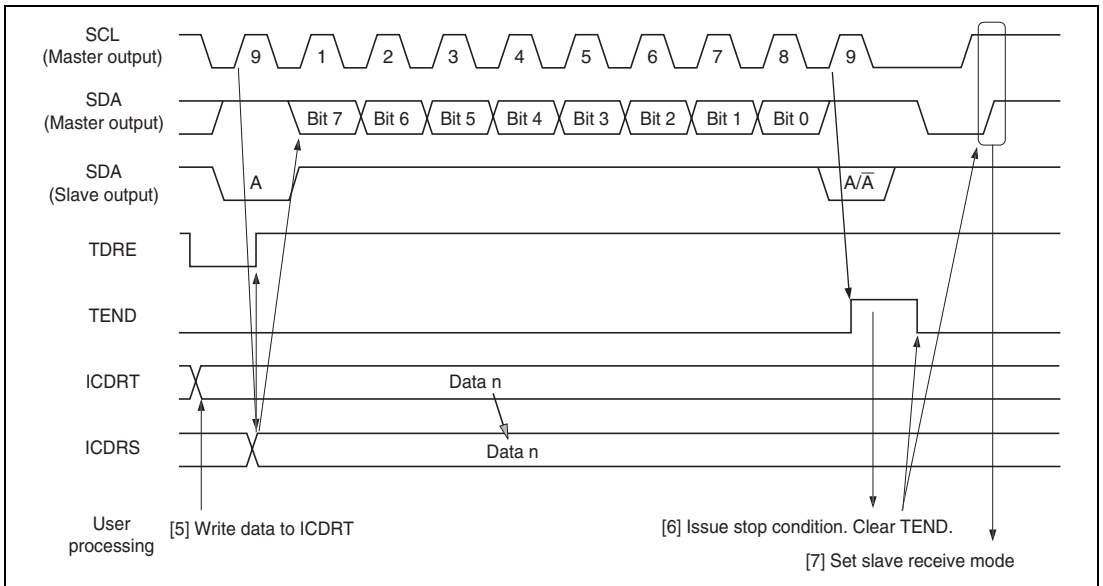

Figure 15.6 Master Transmit Mode Operation Timing (2)

15.4.3 Master Receive Operation

In master receive mode, the master device outputs the receive clock, receives data from the slave device, and returns an acknowledge signal. For master receive mode operation timing, refer to figures 15.7 and 15.8. The reception procedure and operations in master receive mode are shown below.

1. Clear the TEND bit in ICSR to 0, then clear the TRS bit in ICCR1 to 0 to switch from master transmit mode to master receive mode. Then, clear the TDRE bit to 0.
2. When ICDRR is read (dummy data read), reception is started, and the receive clock is output, and data received, in synchronization with the internal clock. The master device outputs the level specified by ACKBT in ICIER to SDA, at the 9th receive clock pulse.
3. After the reception of first frame data is completed, the RDRF bit in ICST is set to 1 at the rise of 9th receive clock pulse. At this time, the receive data is read by reading ICDRR, and RDRF is cleared to 0.
4. The continuous reception is performed by reading ICDRR every time RDRF is set. If 8th receive clock pulse falls after reading ICDRR by the other processing while RDRF is 1, SCL is fixed low until ICDRR is read.
5. If next frame is the last receive data, set the RCVD bit in ICCR1 to 1 before reading ICDRR. This enables the issuance of the stop condition after the next reception.
6. When the RDRF bit is set to 1 at rise of the 9th receive clock pulse, issue the stage condition.
7. When the STOP bit in ICSR is set to 1, read ICDRR. Then clear the RCVD bit to 0.
8. The operation returns to the slave receive mode.

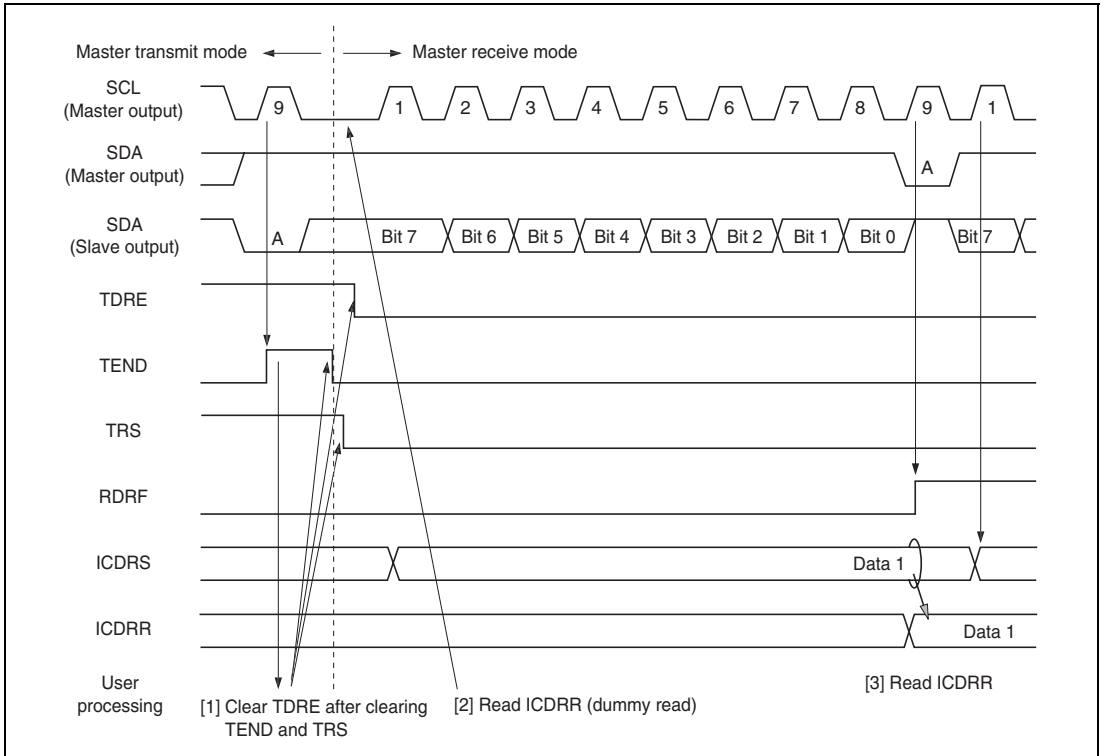

Figure 15.7 Master Receive Mode Operation Timing (1)

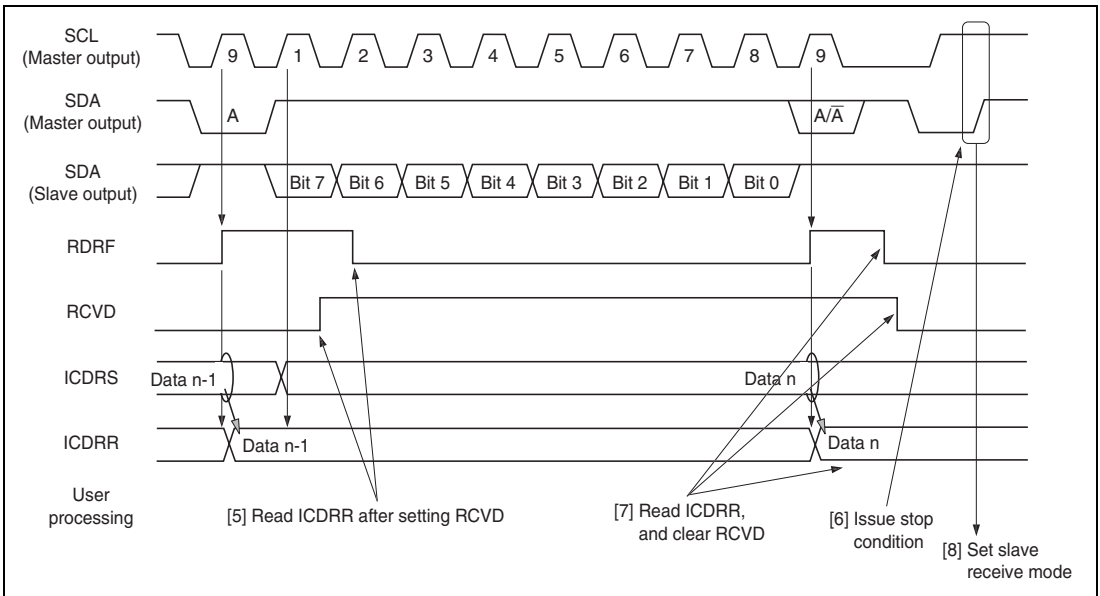

Figure 15.8 Master Receive Mode Operation Timing (2)

15.4.4 Slave Transmit Operation

In slave transmit mode, the slave device outputs the transmit data, while the master device outputs the receive clock and returns an acknowledge signal. For slave transmit mode operation timing, refer to figures 15.9 and 15.10.

The transmission procedure and operations in slave transmit mode are described below.

1. Set the ICE bit in ICCR1 to 1. Set the MLS and WAIT bits in ICMR and the CKS3 to CKS0 bits in ICCR1 to 1. (Initial setting) Set the MST and TRS bits in ICCR1 to select slave receive mode, and wait until the slave address matches.
2. When the slave address matches in the first frame following detection of the start condition, the slave device outputs the level specified by ACKBT in ICIER to SDA, at the rise of the 9th clock pulse. At this time, if the 8th bit data (R/\bar{W}) is 1, the TRS and ICSR bits in ICCR1 are set to 1, and the mode changes to slave transmit mode automatically. The continuous transmission is performed by writing transmit data to ICDRT every time TDRE is set.
3. If TDRE is set after writing last transmit data to ICDRT, wait until TEND in ICSR is set to 1, with TDRE = 1. When TEND is set, clear TEND.
4. Clear TRS for the end processing, and read ICDRR (dummy read). SCL is free.
5. Clear TDRE.

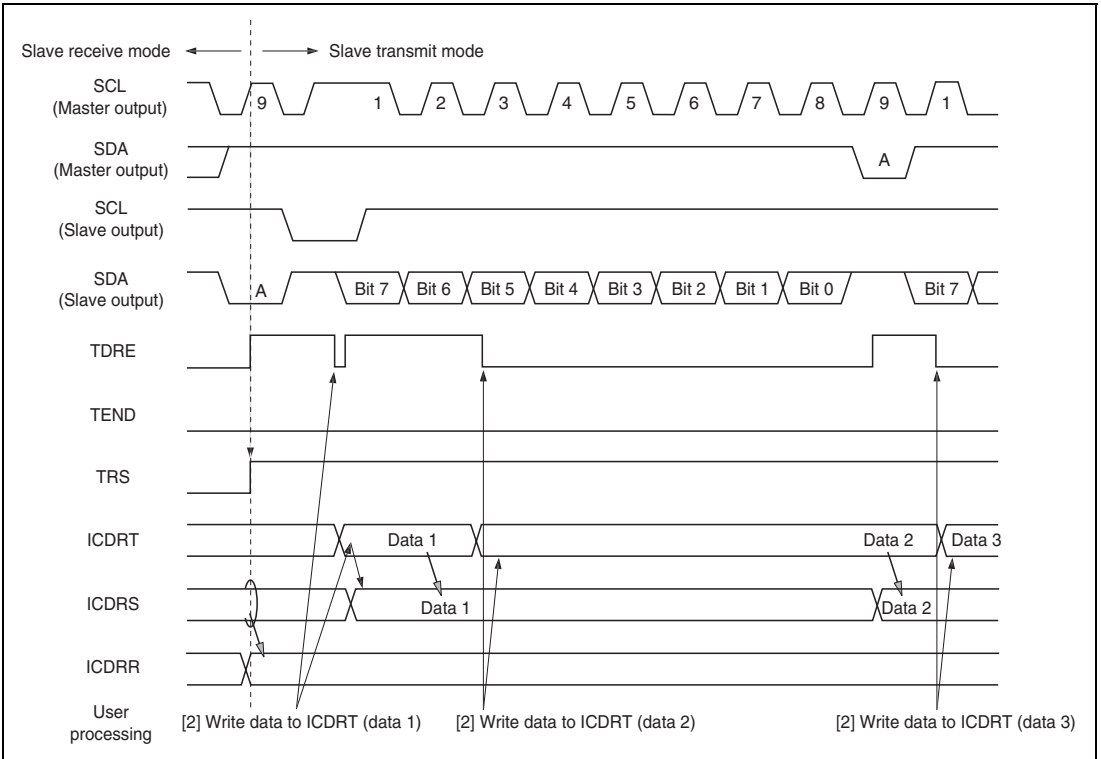

Figure 15.9 Slave Transmit Mode Operation Timing (1)

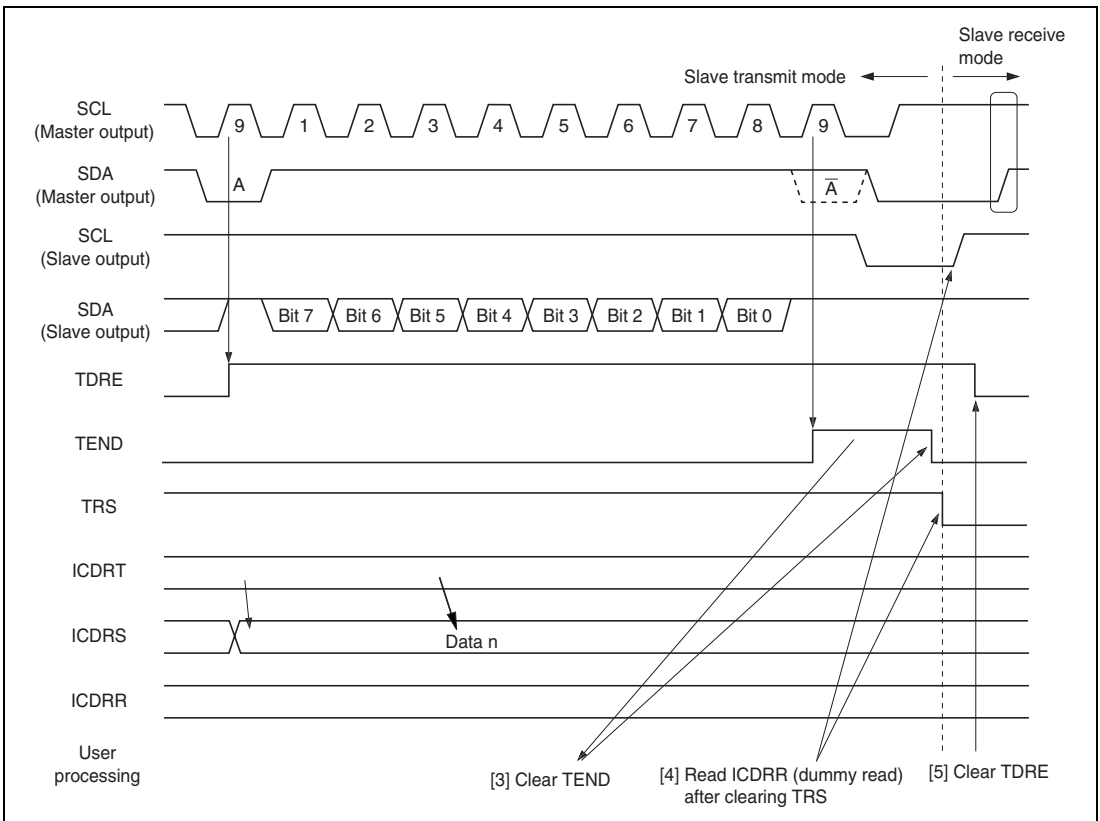

Figure 15.10 Slave Transmit Mode Operation Timing (2)

15.4.5 Slave Receive Operation

In slave receive mode, the master device outputs the transmit clock and transmit data, and the slave device returns an acknowledge signal. For slave receive mode operation timing, refer to figures 15.11 and 15.12. The reception procedure and operations in slave receive mode are described below.

1. Set the ICE bit in ICCR1 to 1. Set the MLS and WAIT bits in ICMR and the CKS3 to CKS0 bits in ICCR1 to 1. (Initial setting) Set the MST and TRS bits in ICCR1 to select slave receive mode, and wait until the slave address matches.
2. When the slave address matches in the first frame following detection of the start condition, the slave device outputs the level specified by ACKBT in ICIER to SDA, at the rise of the 9th clock pulse. At the same time, RDRF in ICSR is set to read ICDRR (dummy read). (Since the read data show the slave address and R/\overline{W} , it is not used.)

3. Read ICDRR every time RDRF is set. If 8th receive clock pulse falls while RDRF is 1, SCL is fixed low until ICDRR is read. The change of the acknowledge before reading ICDRR, to be returned to the master device, is reflected to the next transmit frame.
4. The last byte data is read by reading ICDRR.

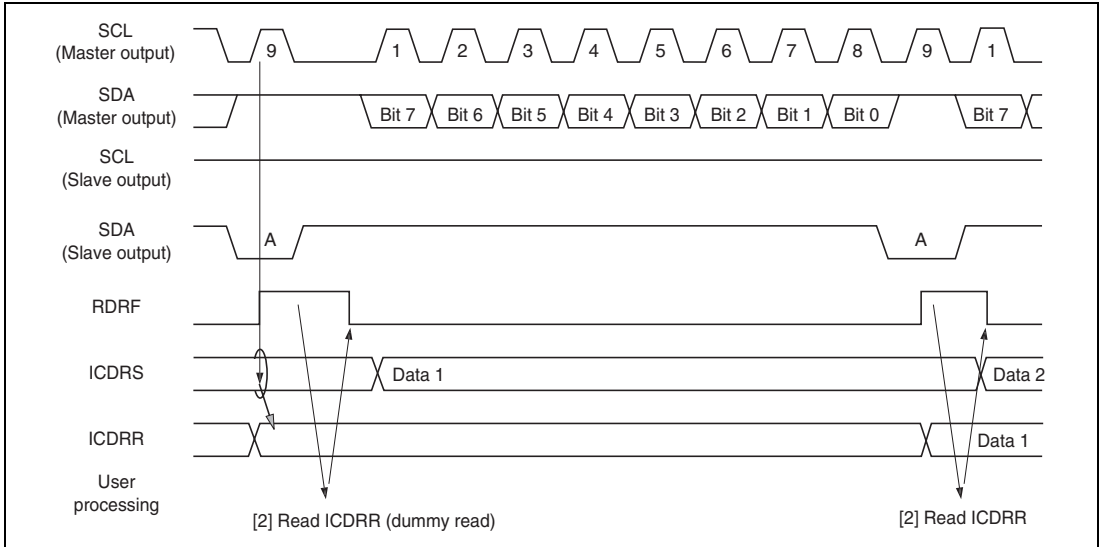

Figure 15.11 Slave Receive Mode Operation Timing (1)

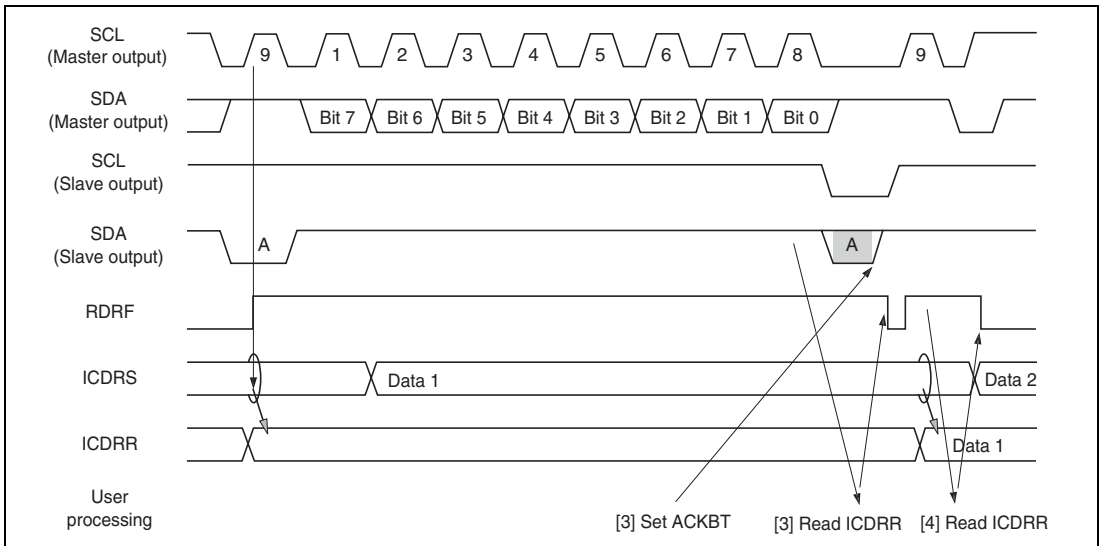

Figure 15.12 Slave Receive Mode Operation Timing (2)

15.4.6 Clocked Synchronous Serial Format

This module can be operated with the clocked synchronous serial format, by setting the FS bit in SAR to 1. When the MST bit in ICCR1 is 1, the transfer clock output from SCL is selected. When MST is 0, the external clock input is selected.

Data Transfer Format

Figure 15.13 shows the clocked synchronous serial transfer format.

The transfer data is output from the rise to the fall of the SCL clock, and the data at the rising edge of the SCL clock is guaranteed. The MLS bit in ICMR sets the order of data transfer, in either the MSB first or LSB first. The output level of SDA can be changed during the transfer wait, by the SDAO bit in ICCR2.

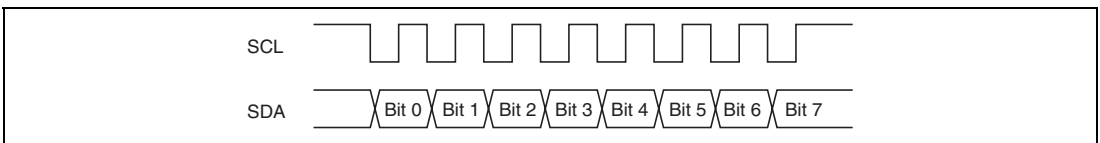

Figure 15.13 Clocked Synchronous Serial Transfer Format

Transmit Operation

In transmit mode, transmit data is output from SDA, in synchronization with the fall of the transfer clock. The transfer clock is output when MST in ICCR1 is 1, and is input when MST is 0. For transmit mode operation timing, refer to figure 15.14. The transmission procedure and operations in transmit mode are described below.

1. Set the ICE bit in ICCR1 to 1. Set the MST and CKS3 to CKS0 bits in ICCR1 to 1. (Initial setting)
2. Set the TRS bit in ICCR1 to select the transmit mode. Then, TDRE in ICSR is set.
3. Confirm that TDRE has been set. Then, write the transmit data to ICDRT. The data is transferred from ICDRT to ICDRS, and TDRE is set automatically. The continuous transmission is performed by writing data to ICDRT every time TDRE is set. When changing from transmit mode to receive mode, clear TRS while TDRE is 1.

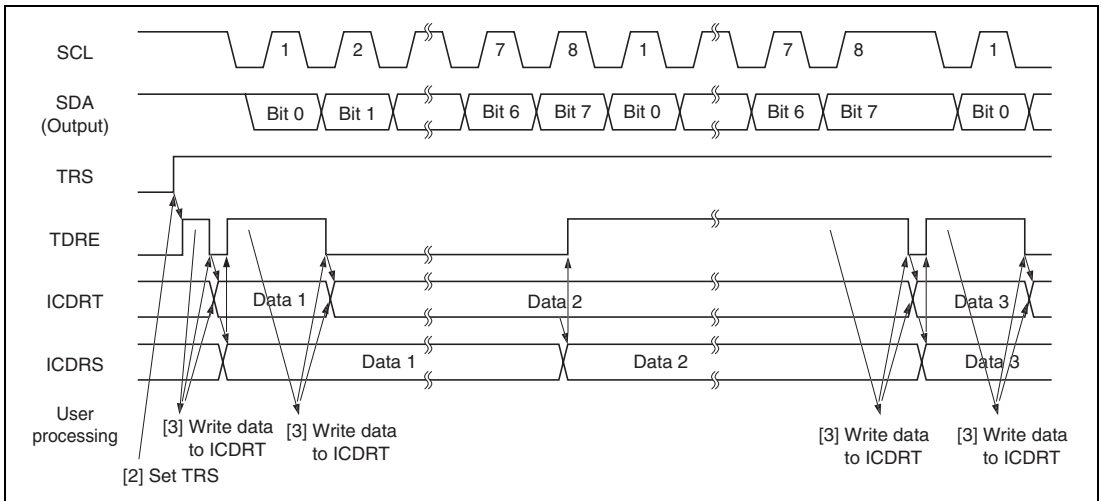

Figure 15.14 Transmit Mode Operation Timing

Receive Operation

In receive mode, data is latched at the rise of the transfer clock. The transfer clock is output when MST in ICCR1 is 1, and is input when MST is 0. For receive mode operation timing, refer to figure 15.15. The reception procedure and operations in receive mode are described below.

1. Set the ICE bit in ICCR1 to 1. Set the MST and CKS3 to CKS0 bits in ICCR1 to 1. (Initial setting)
2. When the transfer clock is output, set MST to 1 to start outputting the receive clock.
3. When the receive operation is completed, data is transferred from ICDRS to ICDRR and RDRF in ICSR is set. When MST = 1, the next byte can be received, so the clock is continually output. The continuous reception is performed by reading ICDRR every time RDRF is set. When the 8th clock is risen while RDRF is 1, the overrun is detected and AL/OVE in ICSR is set. At this time, the previous reception data is retained in ICDRR.
4. To stop receiving when MST = 1, set RCVD in ICCR1 to 1, then read ICDRR. Then, SCL is fixed high after receiving the next byte data.

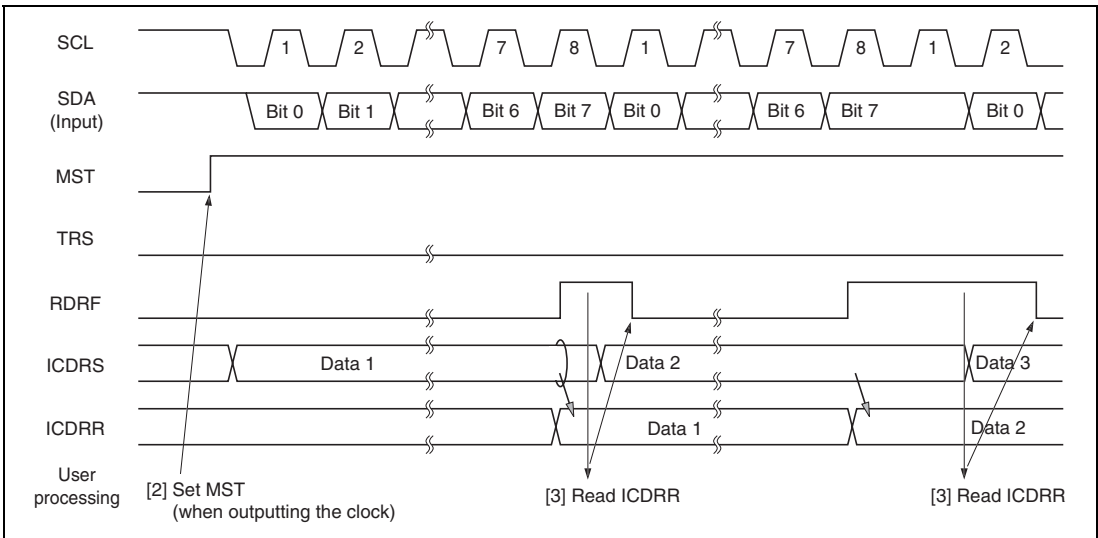

Figure 15.15 Receive Mode Operation Timing

15.4.7 Noise Canceler

The logic levels at the SCL and SDA pins are routed through noise cancelers before being latched internally. Figure 15.16 shows a block diagram of the noise canceler circuit.

The noise canceler consists of two cascaded latches and a match detector. The SCL (or SDA) input signal is sampled on the system clock, but is not passed forward to the next circuit unless the outputs of both latches agree. If they do not agree, the previous value is held.

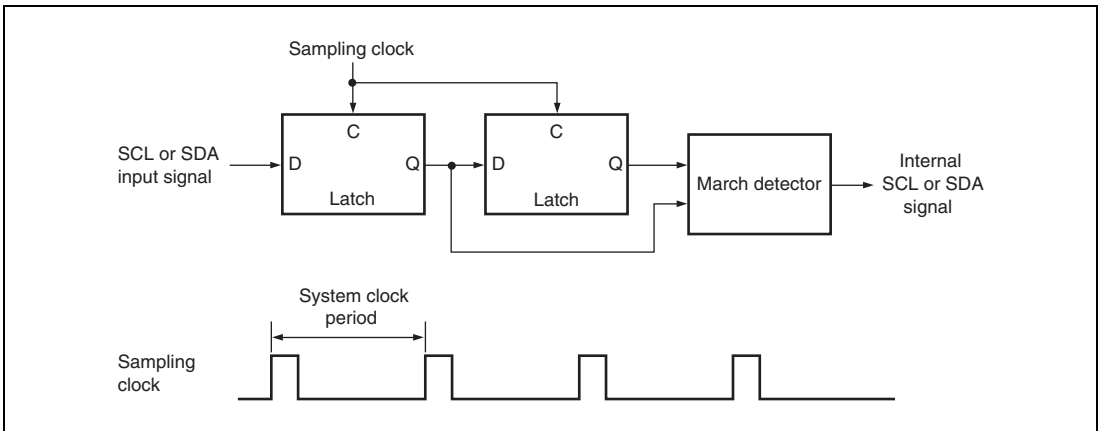

Figure 15.16 Block Diagram of Noise Canceler

15.4.8 Example of Use

Flowcharts in respective modes that use the I²C bus interface are shown in figures 15.17 to 15.20.

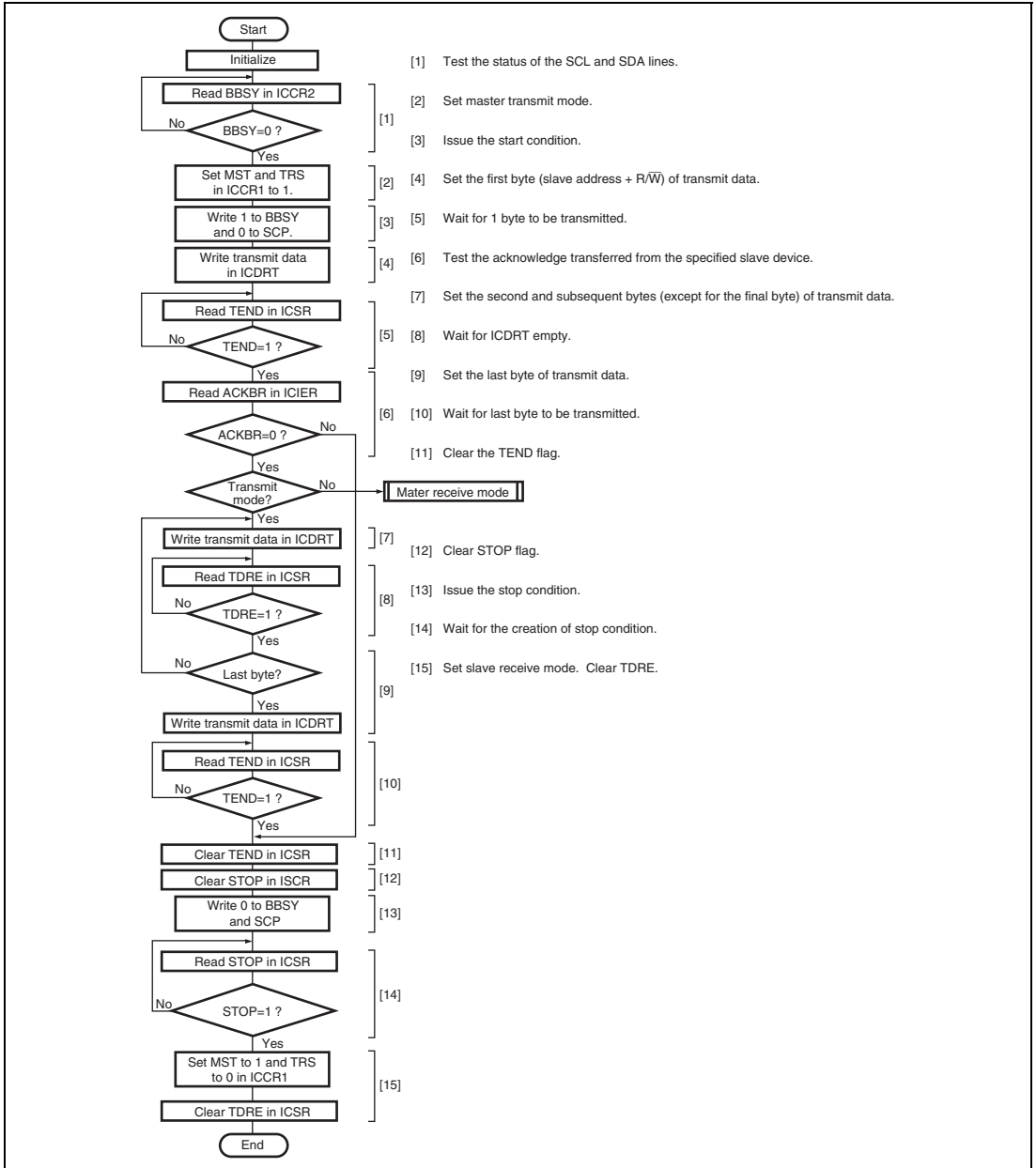

Figure 15.17 Sample Flowchart for Master Transmit Mode

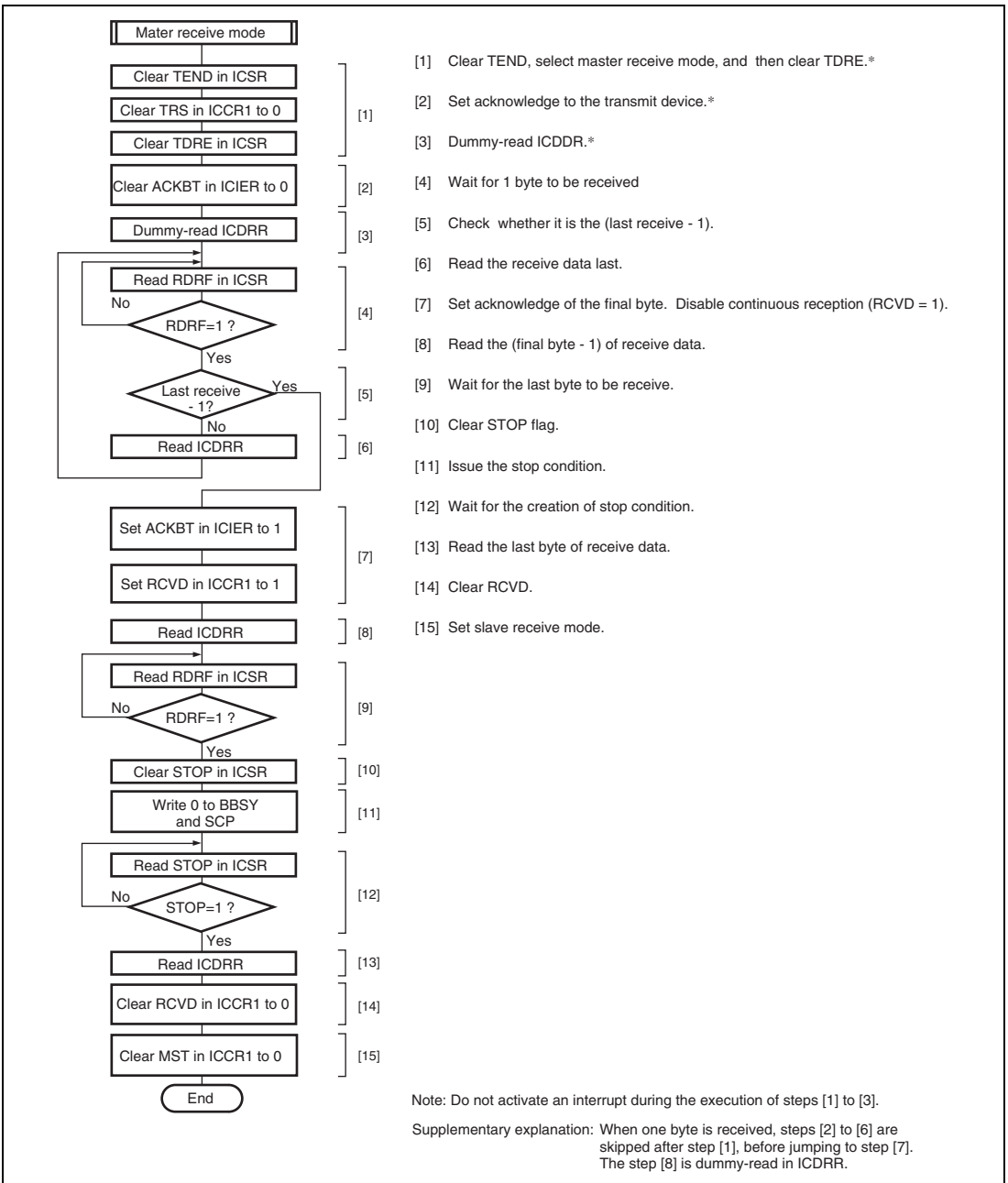

Figure 15.18 Sample Flowchart for Master Receive Mode

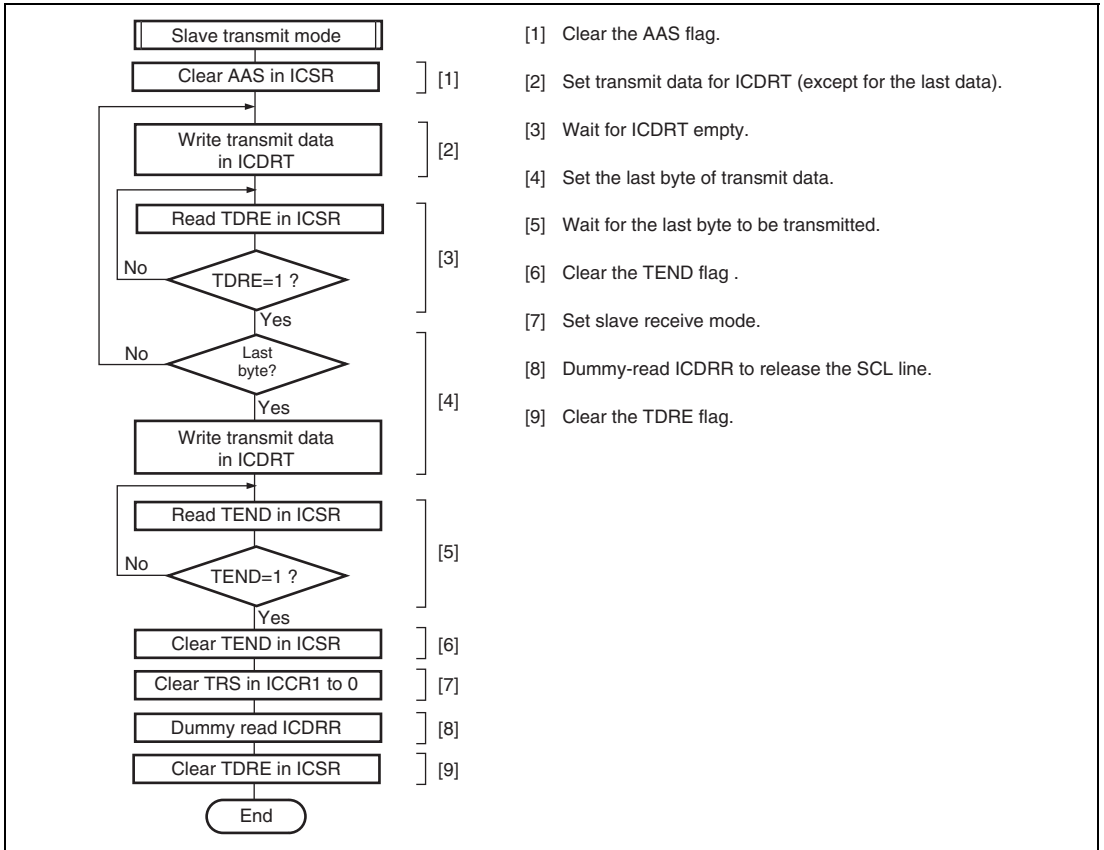
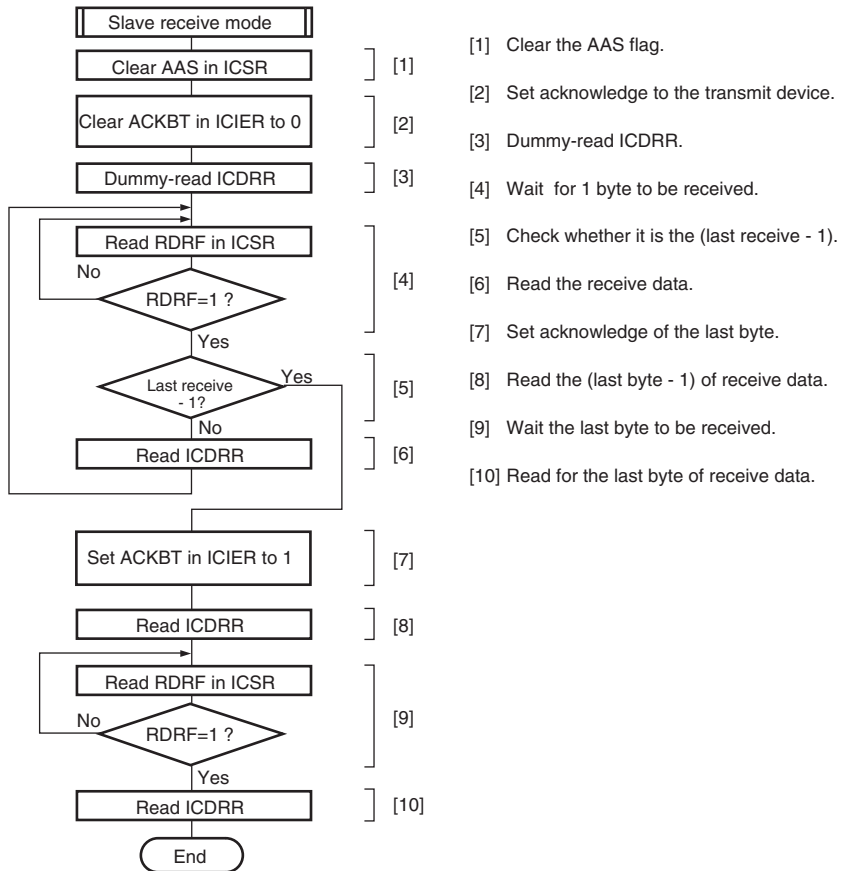

Figure 15.19 Sample Flowchart for Slave Transmit Mode



Supplementary explanation: When one byte is received, steps [2] to [6] are skipped after step [1], before jumping to step [7]. The step [8] is dummy-read in ICDRR.

Figure 15.20 Sample Flowchart for Slave Receive Mode

15.5 Interrupt Request

There are six interrupt requests in this module; transmit data empty, transmit end, receive data full, NACK receive, STOP recognition, and arbitration lost/overrun. Table 15.3 shows the contents of each interrupt request.

Table 15.3 Interrupt Requests

| Interrupt Request | Abbreviation | Interrupt Condition | I ² C Mode | Clocked Synchronous Mode |
|--------------------------|--------------|--|-----------------------|--------------------------|
| Transmit Data Empty | TXI | $(TDRE = 1) \cdot (TIE = 1)$ | ○ | ○ |
| Transmit End | TEI | $(TEND = 1) \cdot (TEIE = 1)$ | ○ | ○ |
| Receive Data Full | RXI | $(RDRF = 1) \cdot (RIE = 1)$ | ○ | ○ |
| STOP Recognition | STPI | $(STOP = 1) \cdot (STIE = 1)$ | ○ | × |
| NACK Receive | NAKI | $\{(NACKF = 1) + (AL = 1)\} \cdot (NAKIE = 1)$ | ○ | × |
| Arbitration Lost/Overrun | | | ○ | ○ |

When interrupt conditions described in table 15.3 are 1 and the I bit in CCR is 0, the CPU executes an interrupt exception processing. Interrupt sources should be cleared in the exception processing. TDRE and TEND are automatically cleared to 0 by writing the transmit data to ICDRT. RDRF are automatically cleared to 0 by reading ICDRR. TDRE is set to 1 again at the same time when transmit data is written to ICDRT. When TDRE is cleared to 0, then an excessive data of one byte may be transmitted.

15.6 Bit Synchronous Circuit

In master mode, this module has a possibility that high level period may be short in the two states described below.

- When SCL is driven to low by the slave device
- When the rising speed of SCL is lowered by the load of the SCL line (load capacitance or pull-up resistance)

Therefore, it monitors SCL and communicates by bit with synchronization.

Figure 15.21 shows the timing of the bit synchronous circuit and table 15.4 shows the time when SCL output changes from low to Hi-Z then SCL is monitored.

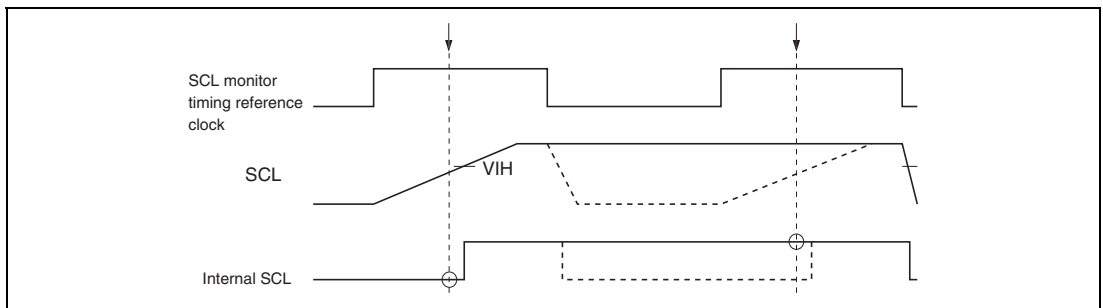

Figure 15.21 The Timing of the Bit Synchronous Circuit

Table 15.4 Time for Monitoring SCL

| CKS3 | CKS2 | Time for Monitoring SCL |
|------|------|-------------------------|
| 0 | 0 | 7.5 tcyc |
| | 1 | 19.5 tcyc |
| 1 | 0 | 17.5 tcyc |
| | 1 | 41.5 tcyc |

15.7 Usage Notes

15.7.1 Issue (Retransmission) of Start/Stop Conditions

In master mode, when the start/stop conditions are issued (retransmitted) at the specific timing under the following condition 1 or 2, such conditions may not be output successfully. To avoid this, issue (retransmit) the start/stop conditions after the fall of the ninth clock is confirmed. Check the SCLO bit in the I²C control register 2 (IICR2) to confirm the fall of the ninth clock.

1. When the rising of SCL falls behind the time specified in section 17.6, Bit Synchronous Circuit, by the load of the SCL bus (load capacitance or pull-up resistance)
2. When the bit synchronous circuit is activated by extending the low period of eighth and ninth clocks, that is driven by the slave device

15.7.2 WAIT Setting in I²C Bus Mode Register (ICMR)

If the WAIT bit is set to 1, and the SCL signal is driven low for two or more transfer clocks by the slave device at the eighth and ninth clocks, the high period of ninth clock may be shortened. To avoid this, set the WAIT bit in ICMR to 0.

Section 16 A/D Converter

This LSI includes a successive approximation type 10-bit A/D converter that allows up to eight analog input channels to be selected. The block diagram of the A/D converter is shown in figure 16.1.

16.1 Features

- 10-bit resolution
- Eight input channels
- Conversion time: at least 3.5 μ s per channel (at 20-MHz operation)
- Two operating modes
 - Single mode: Single-channel A/D conversion
 - Scan mode: Continuous A/D conversion on 1 to 4 channels
- Four data registers
 - Conversion results are held in a data register for each channel
- Sample-and-hold function
- Two conversion start methods
 - Software
 - External trigger signal
- Interrupt request
 - An A/D conversion end interrupt request (ADI) can be generated

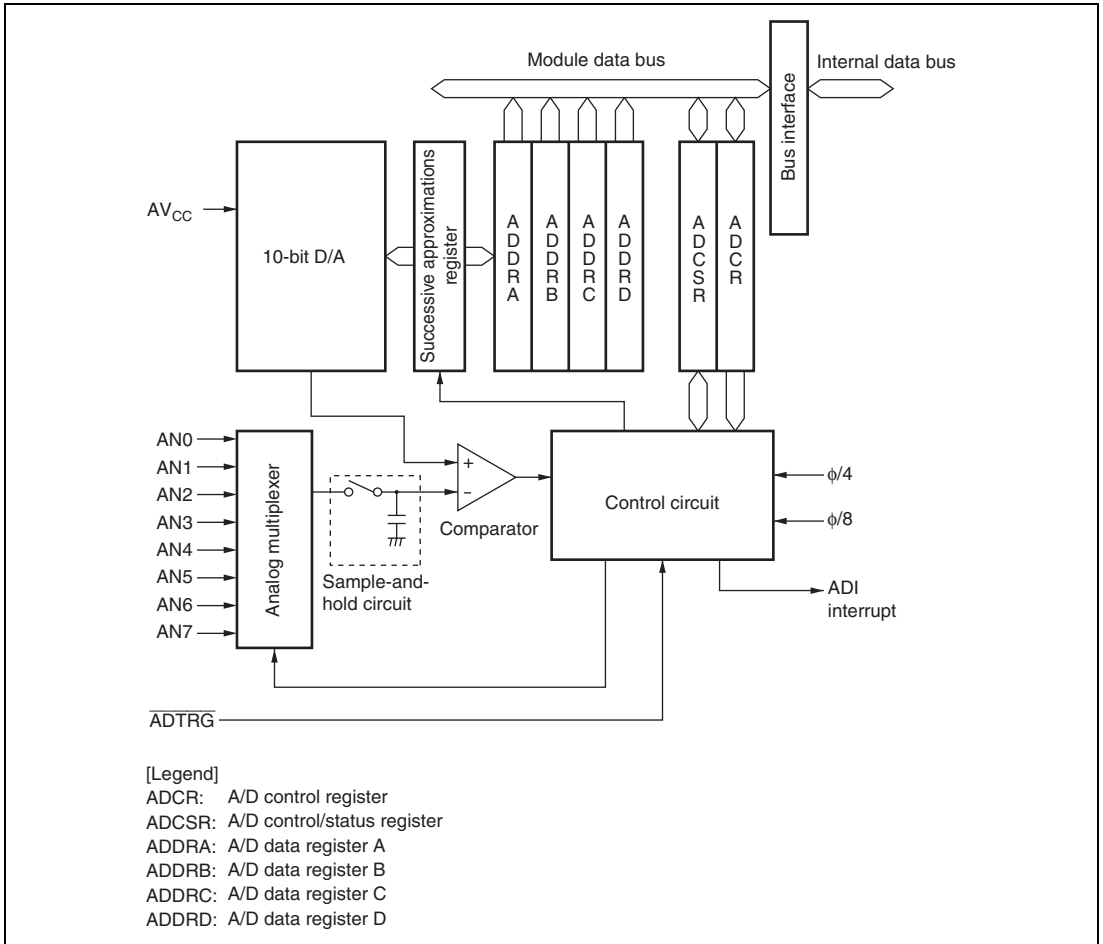

Figure 16.1 Block Diagram of A/D Converter

16.2 Input/Output Pins

Table 16.1 summarizes the input pins used by the A/D converter. The 8 analog input pins are divided into two groups; analog input pins 0 to 3 (AN0 to AN3) comprising group 0, analog input pins 4 to 7 (AN4 to AN7) comprising group 1. The AV_{cc} pin is the power supply pin for the analog block in the A/D converter.

Table 16.1 Pin Configuration

| Pin Name | Abbreviation | I/O | Function |
|--------------------------------|------------------|-------|--|
| Analog power supply pin | AV _{cc} | Input | Analog block power supply |
| Analog input pin 0 | AN0 | Input | Group 0 analog input |
| Analog input pin 1 | AN1 | Input | |
| Analog input pin 2 | AN2 | Input | |
| Analog input pin 3 | AN3 | Input | |
| Analog input pin 4 | AN4 | Input | Group 1 analog input |
| Analog input pin 5 | AN5 | Input | |
| Analog input pin 6 | AN6 | Input | |
| Analog input pin 7 | AN7 | Input | |
| A/D external trigger input pin | ADTRG | Input | External trigger input for starting A/D conversion |

16.3 Register Descriptions

The A/D converter has the following registers.

- A/D data register A (ADDRA)
- A/D data register B (ADDRB)
- A/D data register C (ADDRC)
- A/D data register D (ADDRD)
- A/D control/status register (ADCSR)
- A/D control register (ADCR)

16.3.1 A/D Data Registers A to D (ADDRA to ADDRD)

There are four 16-bit read-only ADDR registers; ADDRA to ADDRD, used to store the results of A/D conversion. The ADDR registers, which store a conversion result for each analog input channel, are shown in table 16.2.

The converted 10-bit data is stored in bits 15 to 6. The lower 6 bits are always read as 0.

The data bus width between the CPU and the A/D converter is 8 bits. The upper byte can be read directly from the CPU, however the lower byte should be read via a temporary register. The temporary register contents are transferred from the ADDR when the upper byte data is read. Therefore byte access to ADDR should be done by reading the upper byte first then the lower one. Word access is also possible. ADDR is initialized to H'0000.

Table 16.2 Analog Input Channels and Corresponding ADDR Registers

| Analog Input Channel | | |
|-----------------------------|----------------|---|
| Group 0 | Group 1 | A/D Data Register to Be Stored Results of A/D Conversion |
| AN0 | AN4 | ADDRA |
| AN1 | AN5 | ADDRB |
| AN2 | AN6 | ADDRC |
| AN3 | AN7 | ADDRD |

16.3.2 A/D Control/Status Register (ADCSR)

ADCSR consists of the control bits and conversion end status bits of the A/D converter.

| Bit | Bit Name | Initial Value | R/W | Description |
|-----|----------|---------------|-----|--|
| 7 | ADF | 0 | R/W | <p>A/D End Flag</p> <p>[Setting conditions]</p> <ul style="list-style-type: none"> • When A/D conversion ends in single mode • When A/D conversion ends once on all the channels selected in scan mode <p>[Clearing condition]</p> <ul style="list-style-type: none"> • When 0 is written after reading ADF = 1 |
| 6 | ADIE | 0 | R/W | <p>A/D Interrupt Enable</p> <p>A/D conversion end interrupt request (ADI) is enabled by ADF when this bit is set to 1</p> |
| 5 | ADST | 0 | R/W | <p>A/D Start</p> <p>Setting this bit to 1 starts A/D conversion. In single mode, this bit is cleared to 0 automatically when conversion on the specified channel is complete. In scan mode, conversion continues sequentially on the specified channels until this bit is cleared to 0 by software, a reset, or a transition to standby mode.</p> |
| 4 | SCAN | 0 | R/W | <p>Scan Mode</p> <p>Selects single mode or scan mode as the A/D conversion operating mode.</p> <p>0: Single mode</p> <p>1: Scan mode</p> |
| 3 | CKS | 0 | R/W | <p>Clock Select</p> <p>Selects the A/D conversions time.</p> <p>0: Conversion time = 134 states (max.)</p> <p>1: Conversion time = 70 states (max.)</p> <p>Clear the ADST bit to 0 before switching the conversion time.</p> |

| Bit | Bit Name | Initial Value | R/W | Description |
|-----|----------|---------------|-----|-------------------------------|
| 2 | CH2 | 0 | R/W | Channel Select 2 to 0 |
| 1 | CH1 | 0 | R/W | Select analog input channels. |
| 0 | CH0 | 0 | R/W | When SCAN = 0 |
| | | | | When SCAN = 1 |
| | | | | 000: AN0 |
| | | | | 001: AN1 |
| | | | | 010: AN2 |
| | | | | 011: AN3 |
| | | | | 100: AN4 |
| | | | | 101: AN5 |
| | | | | 110: AN6 |
| | | | | 111: AN7 |

16.3.3 A/D Control Register (ADCR)

ADCR enables A/D conversion started by an external trigger signal.

| Bit | Bit Name | Initial Value | R/W | Description |
|--------|----------|---------------|-----|--|
| 7 | TRGE | 0 | R/W | Trigger Enable |
| | | | | A/D conversion is started at the falling edge and the rising edge of the external trigger signal ($\overline{\text{ADTRG}}$) when this bit is set to 1. |
| | | | | The selection between the falling edge and rising edge of the external trigger pin ($\overline{\text{ADTRG}}$) conforms to the WPEG5 bit in the interrupt edge select register 2 (IEGR2) |
| 6 to 1 | — | All 1 | — | Reserved |
| | | | | These bits are always read as 1. |
| 0 | — | 0 | R/W | Reserved |
| | | | | Do not set this bit to 1, though the bit is readable/writable. |

16.4 Operation

The A/D converter operates by successive approximation with 10-bit resolution. It has two operating modes; single mode and scan mode. When changing the operating mode or analog input channel, in order to prevent incorrect operation, first clear the bit ADST in ADCSR to 0. The ADST bit can be set at the same time as the operating mode or analog input channel is changed.

16.4.1 Single Mode

In single mode, A/D conversion is performed once for the analog input of the specified single channel as follows:

1. A/D conversion is started when the ADST bit in ADCSR is set to 1, according to software or external trigger input.
2. When A/D conversion is completed, the result is transferred to the corresponding A/D data register of the channel.
3. On completion of conversion, the ADF bit in ADCSR is set to 1. If the ADIE bit is set to 1 at this time, an ADI interrupt request is generated.
4. The ADST bit remains set to 1 during A/D conversion. When A/D conversion ends, the ADST bit is automatically cleared to 0 and the A/D converter enters the wait state.

16.4.2 Scan Mode

In scan mode, A/D conversion is performed sequentially for the analog input of the specified channels (four channels maximum) as follows:

1. When the ADST bit in ADCSR is set to 1 by software or external trigger input, A/D conversion starts on the first channel in the group (AN0 when CH2 = 0, AN4 when CH2 = 1).
2. When A/D conversion for each channel is completed, the result is sequentially transferred to the A/D data register corresponding to each channel.
3. When conversion of all the selected channels is completed, the ADF flag in ADCSR is set to 1. If the ADIE bit is set to 1 at this time, an ADI interrupt requested is generated. A/D conversion starts again on the first channel in the group.
4. The ADST bit is not automatically cleared to 0. Steps [2] and [3] are repeated as long as the ADST bit remains set to 1. When the ADST bit is cleared to 0, A/D conversion stops.

16.4.3 Input Sampling and A/D Conversion Time

The A/D converter has a built-in sample-and-hold circuit. The A/D converter samples the analog input when the A/D conversion start delay time (t_D) has passed after the ADST bit is set to 1, then starts conversion. Figure 16.2 shows the A/D conversion timing. Table 16.3 shows the A/D conversion time.

As indicated in figure 16.2, the A/D conversion time includes t_D and the input sampling time. The length of t_D varies depending on the timing of the write access to ADCSR. The total conversion time therefore varies within the ranges indicated in table 16.3.

In scan mode, the values given in table 16.3 apply to the first conversion time. In the second and subsequent conversions, the conversion time is 128 states (fixed) when $CKS = 0$ and 66 states (fixed) when $CKS = 1$.

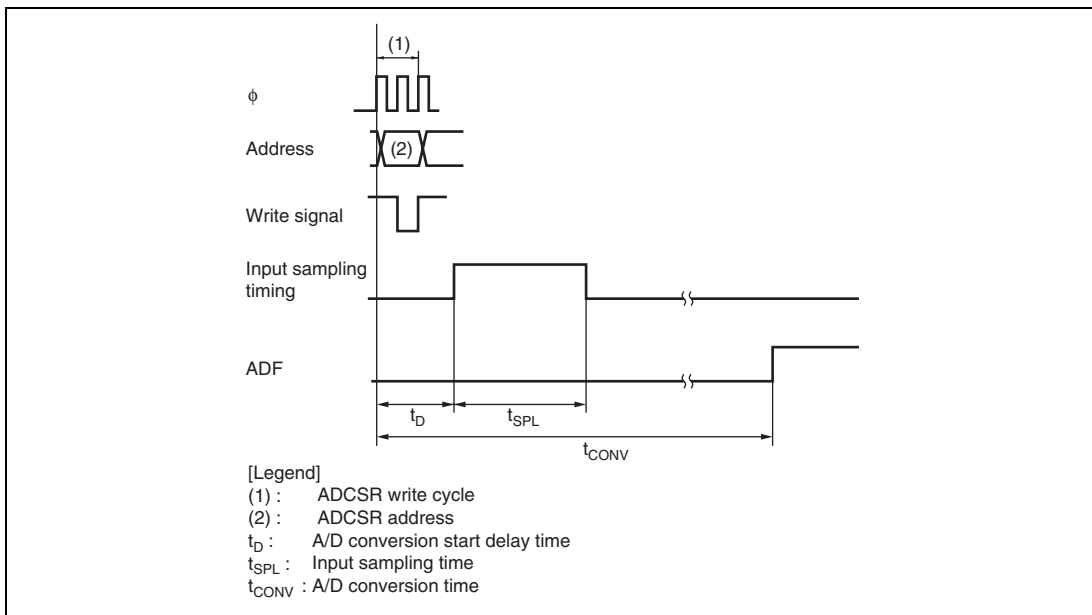

Figure 16.2 A/D Conversion Timing

Table 16.3 A/D Conversion Time (Single Mode)

| Item | Symbol | CKS = 0 | | | CKS = 1 | | |
|---------------------------------|------------|---------|-----|-----|---------|-----|-----|
| | | Min | Typ | Max | Min | Typ | Max |
| A/D conversion start delay time | t_d | 6 | — | 9 | 4 | — | 5 |
| Input sampling time | t_{SPL} | — | 31 | — | — | 15 | — |
| A/D conversion time | t_{CONV} | 131 | — | 134 | 69 | — | 70 |

Note: All values represent the number of states.

16.4.4 External Trigger Input Timing

A/D conversion can also be started by an external trigger input. When the TRGE bit in ADCR is set to 1, external trigger input is enabled at the \overline{ADTRG} pin. A falling edge at the \overline{ADTRG} input pin sets the ADST bit in ADCSR to 1, starting A/D conversion. Other operations, in both single and scan modes, are the same as when the bit ADST has been set to 1 by software. Figure 16.3 shows the timing.

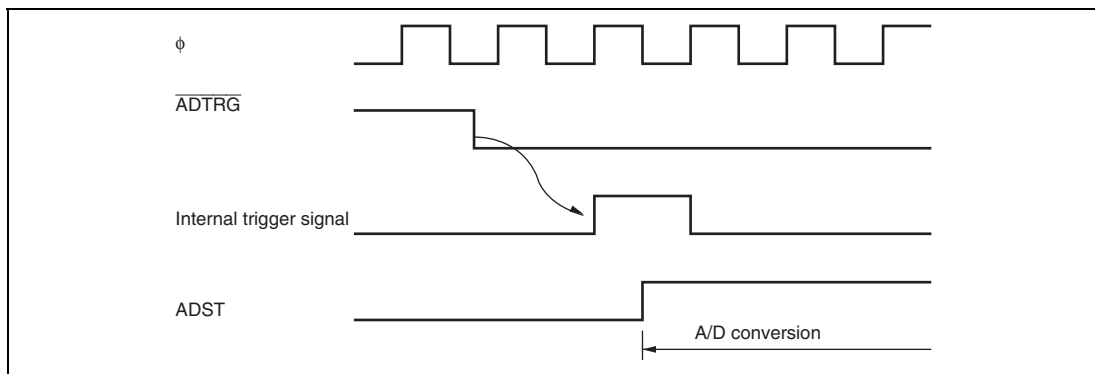
**Figure 16.3 External Trigger Input Timing**

16.5 A/D Conversion Accuracy Definitions

This LSI's A/D conversion accuracy definitions are given below.

- Resolution
The number of A/D converter digital output codes
- Quantization error
The deviation inherent in the A/D converter, given by 1/2 LSB (see figure 16.4).
- Offset error
The deviation of the analog input voltage value from the ideal A/D conversion characteristic when the digital output changes from the minimum voltage value 000000000 to 000000001 (see figure 16.5).
- Full-scale error
The deviation of the analog input voltage value from the ideal A/D conversion characteristic when the digital output changes from 111111110 to 111111111 (see figure 16.5).
- Nonlinearity error
The deviation from the ideal A/D conversion characteristic as the voltage changes from zero to full scale. This does not include the offset error, full-scale error, or quantization error.
- Absolute accuracy
The deviation between the digital value and the analog input value. Includes offset error, full-scale error, quantization error, and nonlinearity error.

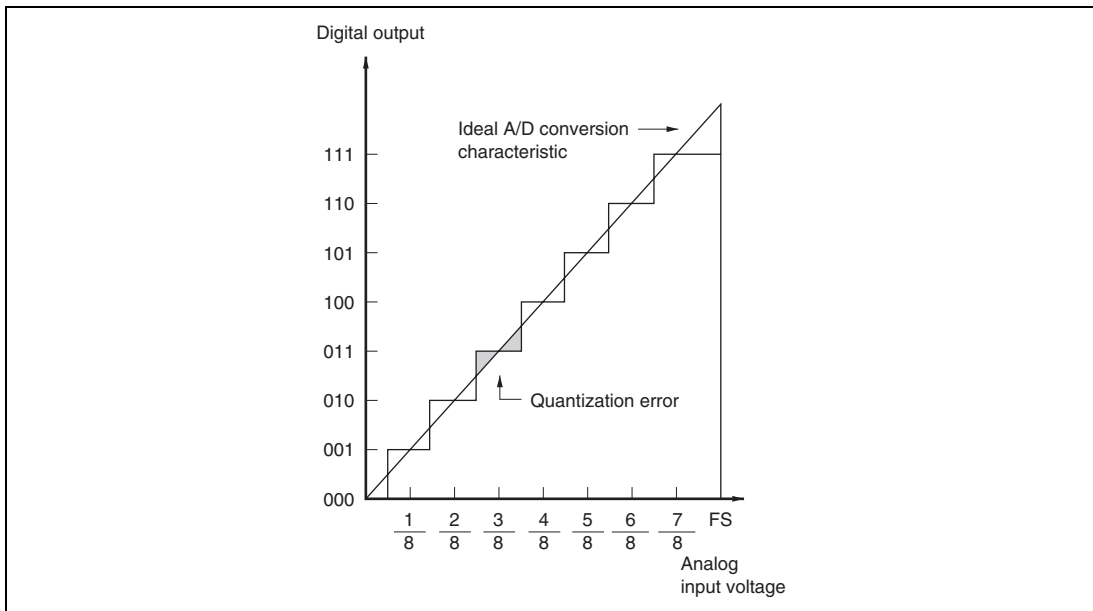

Figure 16.4 A/D Conversion Accuracy Definitions (1)

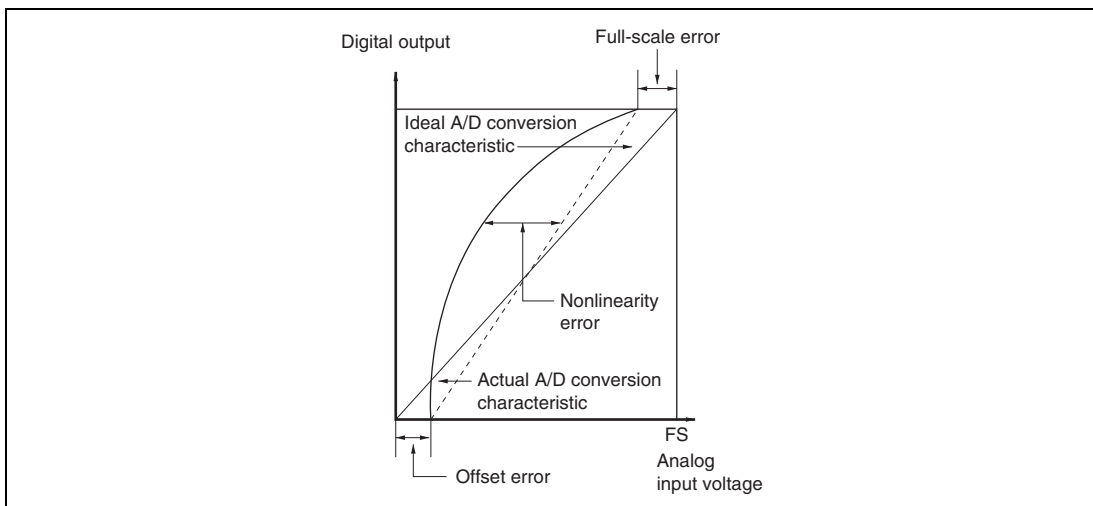

Figure 16.5 A/D Conversion Accuracy Definitions (2)

16.6 Usage Notes

16.6.1 Permissible Signal Source Impedance

This LSI's analog input is designed such that conversion accuracy is guaranteed for an input signal for which the signal source impedance is $5\text{ k}\Omega$ or less. This specification is provided to enable the A/D converter's sample-and-hold circuit input capacitance to be charged within the sampling time; if the sensor output impedance exceeds $5\text{ k}\Omega$, charging may be insufficient and it may not be possible to guarantee A/D conversion accuracy. However, for A/D conversion in single mode with a large capacitance provided externally, the input load will essentially comprise only the internal input resistance of $10\text{ k}\Omega$, and the signal source impedance is ignored. However, as a low-pass filter effect is obtained in this case, it may not be possible to follow an analog signal with a large differential coefficient (e.g., $5\text{ mV}/\mu\text{s}$ or greater) (see figure 16.6). When converting a high-speed analog signal or converting in scan mode, a low-impedance buffer should be inserted.

16.6.2 Influences on Absolute Accuracy

Adding capacitance results in coupling with GND, and therefore noise in GND may adversely affect absolute accuracy. Be sure to make the connection to an electrically stable GND.

Care is also required to ensure that filter circuits do not interfere with digital signals or act as antennas on the mounting board.

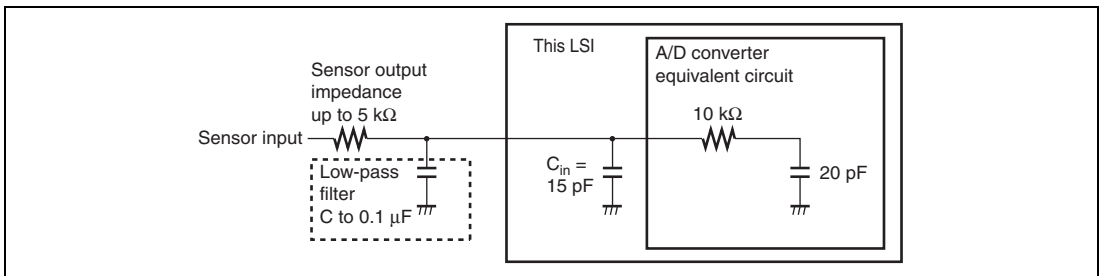

Figure 16.6 Analog Input Circuit Example

Section 17 EEPROM

The H8/3694N has an on-chip 512-byte EEPROM. The block diagram of the EEPROM is shown in figure 17.1.

17.1 Features

- Two writing methods:
 - 1-byte write
 - Page write: Page size 8 bytes
- Three reading methods:
 - Current address read
 - Random address read
 - Sequential read
- Acknowledge polling possible
- Write cycle time:
 - 10 ms (power supply voltage $V_{CC} = 2.7$ V or more)
- Write/Erase endurance:
 - 10^4 cycles/byte (byte write mode), 10^5 cycles/page (page write mode)
- Data retention:
 - 10 years after the write cycle of 10^4 cycles (page write mode)
- Interface with the CPU
 - I²C bus interface (complies with the standard of Philips Corporation)
 - Device code 1010
 - Sleep address code can be changed (initial value: 000)
 - The I²C bus is open to the outside, so the EEPROM can be directly accessed from the outside.

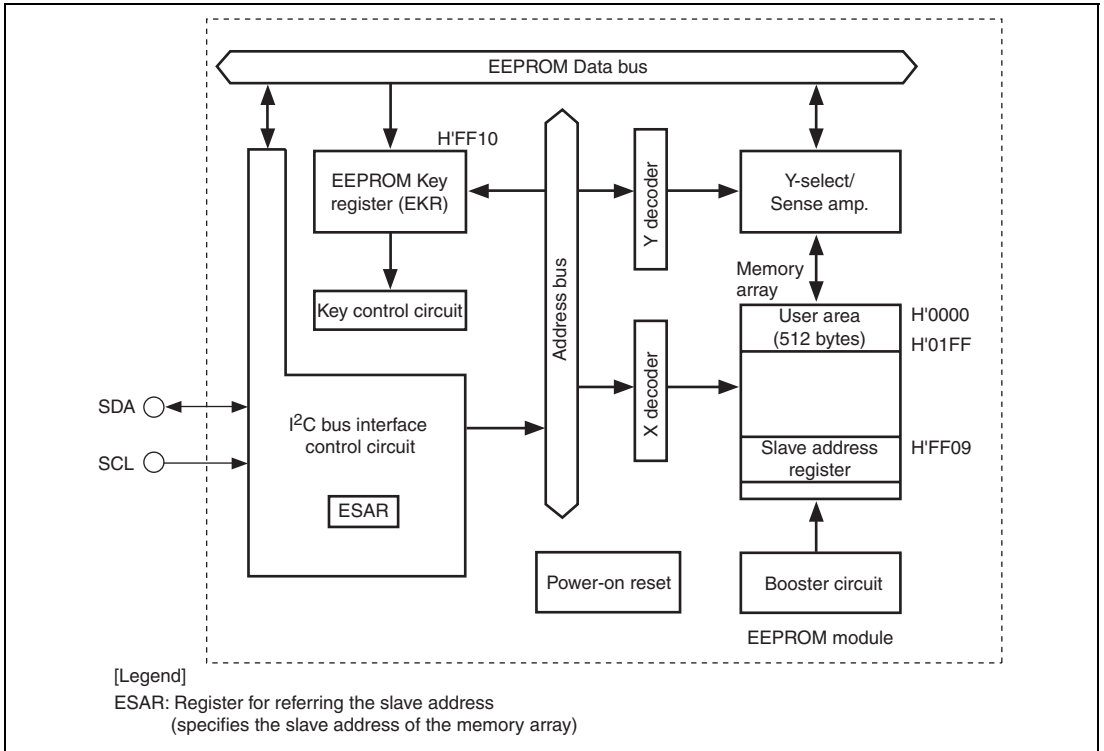

Figure 17.1 Block Diagram of EEPROM

17.2 Input/Output Pins

Pins used in the EEPROM are listed in table 17.1.

Table 17.1 Pin Configuration

| Pin name | Symbol | Input/Output | Function |
|------------------|--------|--------------|---|
| Serial clock pin | SCL | Input | The SCL pin is used to control serial input/output data timing. The data is input at the rising edge of the clock and output at the falling edge of the clock. The SCL pin needs to be pulled up by resistor as that pin is open-drain driven structure of the I ² C pin. Use proper resistor value for your system by considering V_{OL} , I_{OL} , and the C_{IN} pin capacitance in section 21.2.2, DC Characteristics and in section 21.2.3, AC Characteristics. Maximum clock frequency is 400 kHz. |
| Serial data pin | SDA | Input/Output | The SDA pin is bidirectional for serial data transfer. The SDA pin needs to be pulled up by resistor as that pin is open-drain driven structure. Use proper resistor value for your system by considering V_{OL} , I_{OL} , and the C_{IN} pin capacitance in section 21.2.2, DC Characteristics and in section 21.2.3, AC Characteristics. Except for a start condition and a stop condition which will be discussed later, the high-to-low and low-to-high change of SDA input should be done during SCL low periods. |

17.3 Register Description

The EEPROM has a following register.

- EEPROM key register (EKR)

17.3.1 EEPROM Key Register (EKR)

EKR is an 8-bit readable/writable register, which changes the slave address code written in the EEPROM. The slave address code is changed by writing H'5F in EKR and then writing either of H'00 to H'07 as an address code to the H'FF09 address in the EEPROM by the byte write method. EKR is initialized to H'FF.

17.4 Operation

17.4.1 EEPROM Interface

The HD64N3694G has a multi-chip structure with two internal chips of the HD64F3694G (F-ZTAT™ version) and 512-byte EEPROM. The HD6483694G has a multi-chip structure with two internal chips of the HD6433694G (mask-ROM version) and 512-byte EEPROM.

The EEPROM interface is the I²C bus interface. This I²C bus is open to the outside, so the communication with the external devices connected to the I²C bus can be made.

17.4.2 Bus Format and Timing

The I²C bus format and the I²C bus timing follow section 15.4.1, I²C Bus Format. The bus formats specific for the EEPROM are the following two.

1. The EEPROM address is configured of two bytes, the write data is transferred in the order of upper address and lower address from each MSB side.
2. The write data is transmitted from the MSB side.

The bus format and bus timing of the EEPROM are shown in figure 17.2.

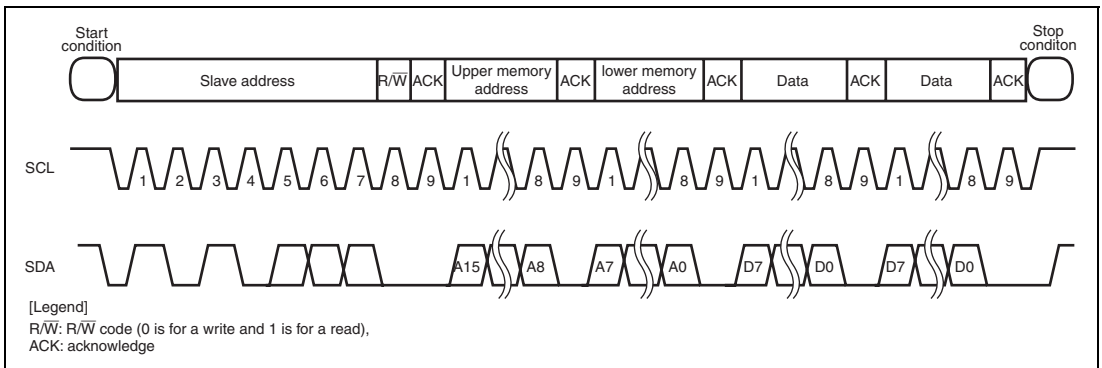

Figure 17.2 EEPROM Bus Format and Bus Timing

17.4.3 Start Condition

A high-to-low transition of the SDA input with the SCL input high is needed to generate the start condition for starting read, write operation.

17.4.4 Stop Condition

A low-to-high transition of the SDA input with the SCL input high is needed to generate the stop condition for stopping read, write operation.

The standby operation starts after a read sequence by a stop condition. In the case of write operation, a stop condition terminates the write data inputs and place the device in an internally-timed write cycle to the memories. After the internally-timed write cycle (t_{wc}) which is specified as t_{wc} , the device enters a standby mode.

17.4.5 Acknowledge

All address data and serial data such as read data and write data are transmitted to and from in 8-bit unit. The acknowledgement is the signal that indicates that this 8-bit data is normally transmitted to and from.

In the write operation, EEPROM sends "0" to acknowledge in the ninth cycle after receiving the data. In the read operation, EEPROM sends a read data following the acknowledgement after receiving the data. After sending read data, the EEPROM enters the bus open state. If the EEPROM receives "0" as an acknowledgement, it sends read data of the next address. If the EEPROM does not receive acknowledgement "0" and receives a following stop condition, it stops the read operation and enters a standby mode. If the EEPROM receives neither acknowledgement "0" nor a stop condition, the EEPROM keeps bus open without sending read data.

17.4.6 Slave Addressing

The EEPROM device receives a 7-bit slave address and a 1-bit $\overline{R/\overline{W}}$ code following the generation of the start conditions. The EEPROM enables the chip for a read or a write operation with this operation.

The slave address consists of a former 4-bit device code and latter 3-bit slave address as shown in table 17.2. The device code is used to distinguish device type and this LSI uses "1010" fixed code in the same manner as in a general-purpose EEPROM. The slave address code selects one device out of all devices with device code 1010 (8 devices in maximum) which are connected to the I²C bus. This means that the device is selected if the inputted slave address code received in the order of A2, A1, A0 is equal to the corresponding slave address reference register (ESAR).

The slave address code is stored in the address H'FF09 in the EEPROM. It is transferred to ESAR from the slave address register in the memory array during 10 ms after the reset is released. An access to the EEPROM is not allowed during transfer.

The initial value of the slave address code written in the EEPROM is H'00. It can be written in the range of H'00 to H'07. Be sure to write the data by the byte write method.

The next one bit of the slave address is the $\overline{R/W}$ code. 0 is for a write and 1 is for a read.

The EEPROM turns to a standby state if the device code is not "1010" or slave address code doesn't coincide.

Table 17.2 Slave Addresses

| Bit | Bit name | Initial Value | Setting Value | Remarks |
|-----|-----------------------|---------------|---------------|----------------------------------|
| 7 | Device code D3 | — | 1 | |
| 6 | Device code D2 | — | 0 | |
| 5 | Device code D1 | — | 1 | |
| 4 | Device code D0 | — | 0 | |
| 3 | Slave address code A2 | 0 | A2 | The initial value can be changed |
| 2 | Slave address code A1 | 0 | A1 | The initial value can be changed |
| 1 | Slave address code A0 | 0 | A0 | The initial value can be changed |

17.4.7 Write Operations

There are two types write operations; byte write operation and page write operation. To initiate the write operation, input 0 to R/\bar{W} code following the slave address.

1. Byte Write

A write operation requires an 8-bit data of a 7-bit slave address with R/\bar{W} code = "0". Then the EEPROM sends acknowledgement "0" at the ninth bit. This enters the write mode. Then, two bytes of the memory address are received from the MSB side in the order of upper and lower. Upon receipt of one-byte memory address, the EEPROM sends acknowledgement "0" and receives a following a one-byte write data. After receipt of write data, the EEPROM sends acknowledgement "0". If the EEPROM receives a stop condition, the EEPROM enters an internally controlled write cycle and terminates receipt of SCL and SDA inputs until completion of the write cycle. The EEPROM returns to a standby mode after completion of the write cycle.

The byte write operation is shown in figure 17.3.

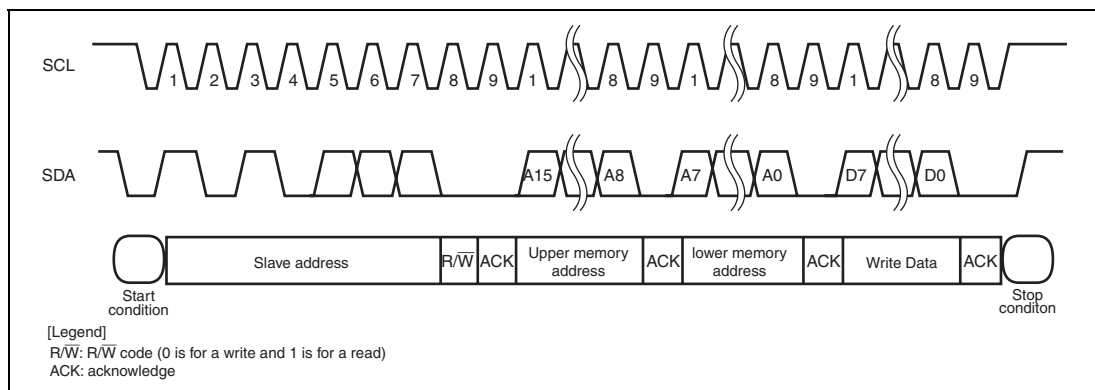

Figure 17.3 Byte Write Operation

2. Page Write

This LSI is capable of the page write operation which allows any number of bytes up to 8 bytes to be written in a single write cycle. The write data is input in the same sequence as the byte write in the order of a start condition, slave address + R/\bar{W} code, memory address (n), and write data (Dn) with every ninth bit acknowledgement "0" output. The EEPROM enters the page write operation if the EEPROM receives more write data (Dn+1) is input instead of receiving a stop condition after receiving the write data (Dn). LSB 3 bits (A2 to A0) in the EEPROM address are automatically incremented to be the (n+1) address upon receiving write data (Dn+1). Thus the write data can be received sequentially.

Addresses in the page are incremented at each receipt of the write data and the write data can be input up to 8 bytes. If the LSB 3 bits (A2 to A0) in the EEPROM address reach the last address of the page, the address will roll over to the first address of the same page. When the address is rolled over, write data is received twice or more to the same address, however, the last received data is valid. At the receipt of the stop condition, write data reception is terminated and the write operation is entered.

The page write operation is shown in figure 17.4.

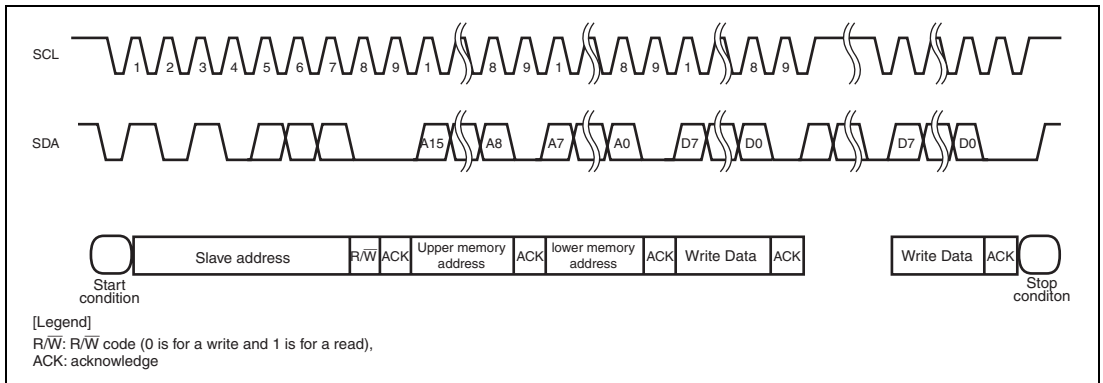

Figure 17.4 Page Write Operation

17.4.8 Acknowledge Polling

Acknowledge polling feature is used to show if the EEPROM is in an internally-timed write cycle or not. This feature is initiated by the input of the 8-bit slave address + R/\bar{W} code following the start condition during an internally-timed write cycle. Acknowledge polling will operate R/\bar{W} code = "0". The ninth acknowledgement judges if the EEPROM is an internally-timed write cycle or not. Acknowledgement "1" shows the EEPROM is in an internally-timed write cycle and acknowledgement "0" shows the internally-timed write cycle has been completed. The acknowledge polling starts to function after a write data is input, i.e., when the stop condition is input.

17.4.9 Read Operation

There are three read operations; current address read, random address read, and sequential read. Read operations are initiated in the same way as write operations with the exception of $R/\overline{W} = 1$.

1. Current Address Read

The internal address counter maintains the (n+1) address that is made by the last address (n) accessed during the last read or write operation, with incremented by one. Current address read accesses the (n+1) address kept by the internal address counter.

After receiving in the order of a start condition and the slave address + R/\overline{W} code ($R/\overline{W} = 1$), the EEPROM outputs the 1-byte data of the (n+1) address from the most significant bit following acknowledgement "0". If the EEPROM receives in the order of acknowledgement "1" and a following stop condition, the EEPROM stops the read operation and is turned to a standby state.

In case the EEPROM has accessed the last address H'01FF at previous read operation, the current address will roll over and returns to zero address. In case the EEPROM has accessed the last address of the page at previous write operation, the current address will roll over within page addressing and returns to the first address in the same page.

The current address is valid while power is on. The current address after power on will be undefined. After power is turned on, define the address by the random address read operation described below is necessary.

The current address read operation is shown in figure 17.5.

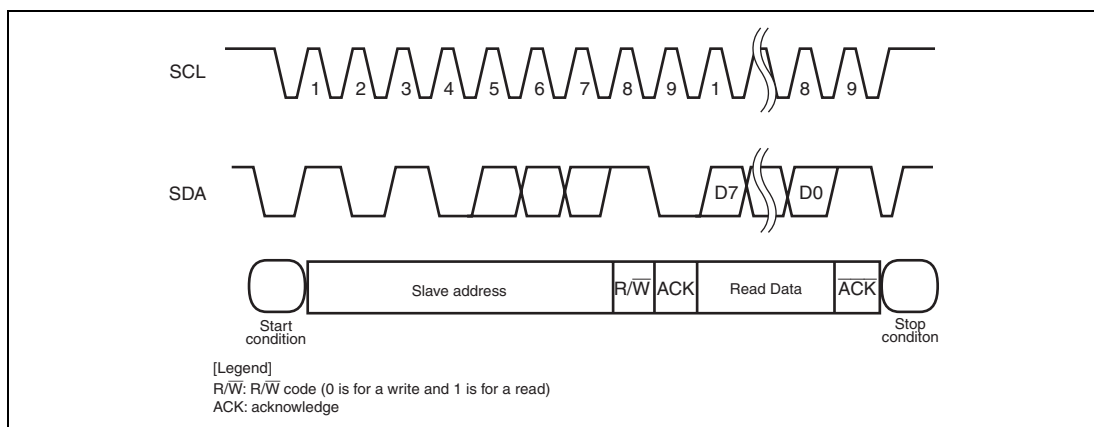

Figure 17.5 Current Address Read Operation

2. Random Address Read

This is a read operation with defined read address. A random address read requires a dummy write to set read address. The EEPROM receives a start condition, slave address + R/\overline{W} code ($R/\overline{W} = 0$), memory address (upper) and memory address (lower) sequentially. The EEPROM outputs acknowledgement "0" after receiving memory address (lower) then enters a current address read with receiving a start condition again. The EEPROM outputs the read data of the address which was defined in the dummy write operation. After receiving acknowledgement "1" and a following stop condition, the EEPROM stops the random read operation and returns to a standby state.

The random address read operation is shown in figure 17.6.

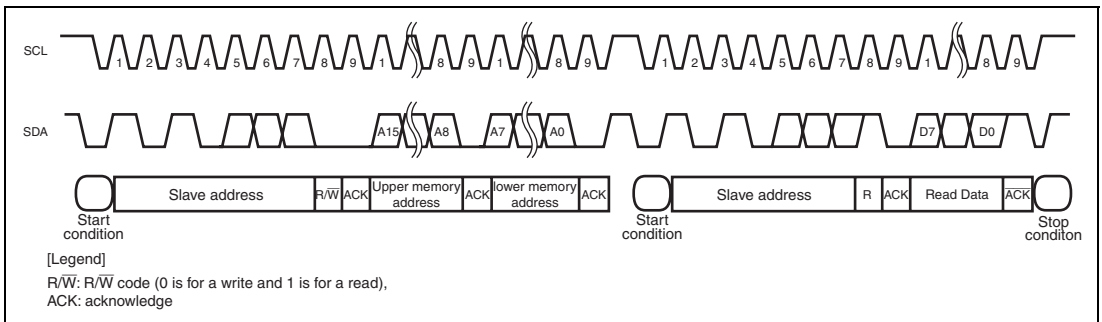

Figure 17.6 Random Address Read Operation

3. Sequential Read

This is a mode to read the data sequentially. Data is sequential read by either a current address read or a random address read. If the EEPROM receives acknowledgement "0" after 1-byte read data is output, the read address is incremented and the next 1-byte read data are coming out. Data is output sequentially by incrementing addresses as long as the EEPROM receives acknowledgement "0" after the data is output. The address will roll over and returns address zero if it reaches the last address H'01FF. The sequential read can be continued after roll over. The sequential read is terminated if the EEPROM receives acknowledgement "1" and a following stop condition as the same manner as in the random address read.

The condition of a sequential read when the current address read is used is shown in figure 17.7.

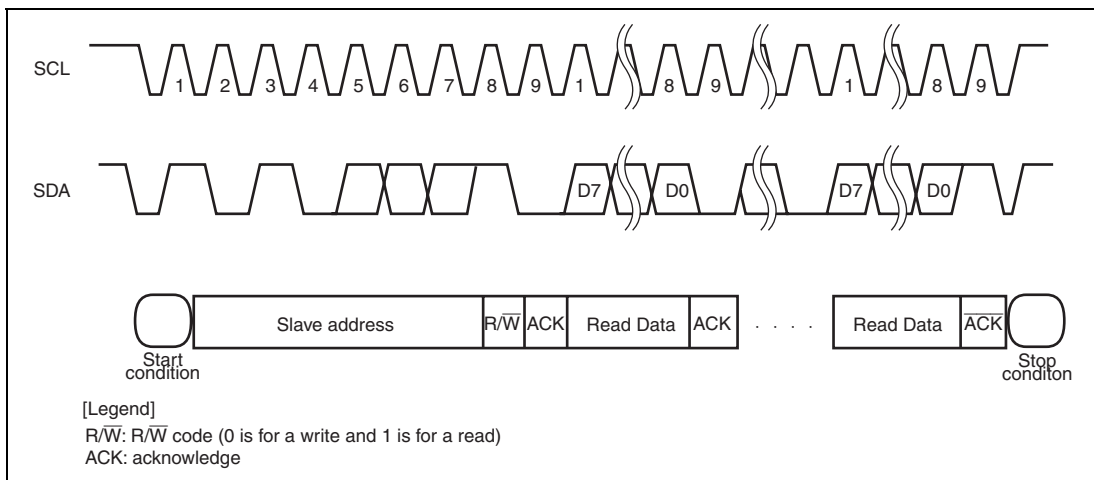

Figure 17.7 Sequential Read Operation (when current address read is used)

17.5 Usage Notes

17.5.1 Data Protection at V_{CC} On/Off

When V_{CC} is turned on or off, the data might be destroyed by malfunction. Be careful of the notices described below to prevent the data to be destroyed.

1. SCL and SDA should be fixed to V_{CC} or V_{SS} during V_{CC} on/off.
2. V_{CC} should be turned off after the EEPROM is placed in a standby state.
3. When V_{CC} is turned on from the intermediate level, malfunction is caused, so V_{CC} should be turned on from the ground level (V_{SS}).
4. V_{CC} turn on speed should be longer than 10 μ s.

17.5.2 Write/Erase Endurance

The endurance is 10^5 cycles/page (1% cumulative failure rate) in case of page programming and 10^4 cycles/byte in case of byte programming. The data retention time is more than 10 years when a device is page-programmed less than 10^4 cycles.

17.5.3 Noise Suppression Time

This EEPROM has a noise suppression function at SCL and SDA inputs, that cuts noise of width less than 50 ns. Be careful not to allow noise of width more than 50 ns because the noise of with more than 50 ns is recognized as an active pulse.

Section 18 Power-On Reset and Low-Voltage Detection Circuits (Optional)

This LSI can include a power-on reset circuit and low-voltage detection circuit as optional circuits.

The low-voltage detection circuit consists of two circuits: LVDI (interrupt by low voltage detect) and LVDR (reset by low voltage detect) circuits.

This circuit is used to prevent abnormal operation (runaway execution) from occurring due to the power supply voltage fall and to recreate the state before the power supply voltage fall when the power supply voltage rises again.

Even if the power supply voltage falls, the unstable state when the power supply voltage falls below the guaranteed operating voltage can be removed by entering standby mode when exceeding the guaranteed operating voltage and during normal operation. Thus, system stability can be improved. If the power supply voltage falls more, the reset state is automatically entered. If the power supply voltage rises again, the reset state is held for a specified period, then active mode is automatically entered.

Figure 18.1 is a block diagram of the power-on reset circuit and the low-voltage detection circuit.

18.1 Features

- Power-on reset circuit
Uses an external capacitor to generate an internal reset signal when power is first supplied.
- Low-voltage detection circuit
LVDR: Monitors the power-supply voltage, and generates an internal reset signal when the voltage falls below a specified value.
LVDI: Monitors the power-supply voltage, and generates an interrupt when the voltage falls below or rises above respective specified values.
Two pairs of detection levels for reset generation voltage are available: when only the LVDR circuit is used, or when the LVDI and LVDR circuits are both used.

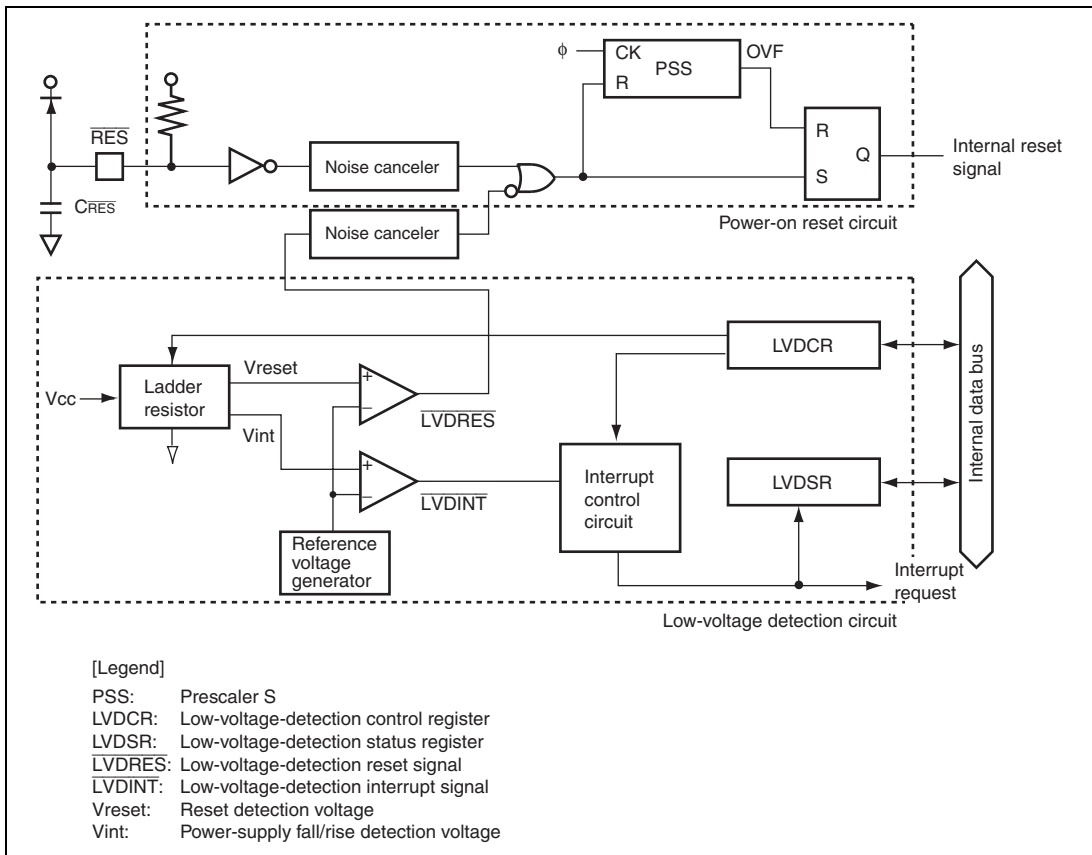

Figure 18.1 Block Diagram of Power-On Reset Circuit and Low-Voltage Detection Circuit

18.2 Register Descriptions

The low-voltage detection circuit has the following registers.

- Low-voltage-detection control register (LVDCR)
- Low-voltage-detection status register (LVDSR)

18.2.1 Low-Voltage-Detection Control Register (LVDCR)

LVDCR is used to enable or disable the low-voltage detection circuit, set the detection levels for the LVDCR function, enable or disable the LVDCR function, and enable or disable generation of an interrupt when the power-supply voltage rises above or falls below the respective levels.

Table 18.1 shows the relationship between the LVDCR settings and select functions. LVDCR should be set according to table 18.1.

| Bit | Bit Name | Initial Value | R/W | Description |
|--------|----------|---------------|-----|---|
| 7 | LVDE | 0* | R/W | LVD Enable 0: The low-voltage detection circuit is not used (In standby mode) 1: The low-voltage detection circuit is used |
| 6 to 4 | — | All 1 | — | Reserved These bits are always read as 1, and cannot be modified. |
| 3 | LVDSSEL | 0* | R/W | LVDR Detection Level Select 0: Reset detection voltage is 2.3 V (typ.) 1: Reset detection voltage is 3.6 V (typ.) When the falling or rising voltage detection interrupt is used, reset detection voltage of 2.3 V (typ.) should be used. When only a reset detection interrupt is used, reset detection voltage of 3.6 V (typ.) should be used. |
| 2 | LVDRE | 0* | R/W | LVDR Enable 0: Disables the LVDR function 1: Enables the LVDR function |
| 1 | LVDDE | 0 | R/W | Voltage-Fall-Interrupt Enable 0: Interrupt on the power-supply voltage falling below the selected detection level disabled 1: Interrupt on the power-supply voltage falling below the selected detection level enabled |
| 0 | LVDUE | 0 | R/W | Voltage-Rise-Interrupt Enable 0: Interrupt on the power-supply voltage rising above the selected detection level disabled 1: Interrupt on the power-supply voltage rising above the selected detection level enabled |

Note: * Not initialized by LVDR but initialized by a power-on reset or WDT reset.

Table 18.1 LVDCR Settings and Select Functions

| LVDCR Settings | | | | | Select Functions | | | | |
|----------------|---------|-------|-------|-------|------------------|------|---|--|--|
| LVDE | LVDSSEL | LVDRE | LVDDE | LVDUE | Power-On Reset | LVDR | Low-Voltage-Detection Falling Interrupt | Low-Voltage-Detection Rising Interrupt | |
| 0 | * | * | * | * | 0 | — | — | — | |
| 1 | 1 | 1 | 0 | 0 | 0 | 0 | — | — | |
| 1 | 0 | 0 | 1 | 0 | 0 | — | 0 | — | |
| 1 | 0 | 0 | 1 | 1 | 0 | — | 0 | 0 | |
| 1 | 0 | 1 | 1 | 1 | 0 | 0 | 0 | 0 | |

Legend: *: means invalid.

18.2.2 Low-Voltage-Detection Status Register (LVDSR)

LVDSR indicates whether the power-supply voltage falls below or rises above the respective specified values.

| Bit | Bit Name | Initial Value | R/W | Description |
|--------|----------|---------------|-----|---|
| 7 to 2 | — | All 1 | — | Reserved These bits are always read as 1, and cannot be modified. |
| 1 | LVDDF | 0* | R/W | LVD Power-Supply Voltage Fall Flag [Setting condition] When the power-supply voltage falls below Vint (D) (typ. = 3.7 V) [Clearing condition] Writing 0 to this bit after reading it as 1 |
| 0 | LVDFUF | 0* | R/W | LVD Power-Supply Voltage Rise Flag [Setting condition] When the power supply voltage falls below Vint (D) while the LVDUE bit in LVDCR is set to 1, then rises above Vint (U) (typ. = 4.0 V) before falling below Vreset1 (typ. = 2.3 V) [Clearing condition] Writing 0 to this bit after reading it as 1 |

Note: * Initialized by LVDR.

18.3 Operation

18.3.1 Power-On Reset Circuit

Figure 18.2 shows the timing of the operation of the power-on reset circuit. As the power-supply voltage rises, the capacitor which is externally connected to the $\overline{\text{RES}}$ pin is gradually charged via the on-chip pull-up resistor (typ. 150 k Ω). Since the state of the $\overline{\text{RES}}$ pin is transmitted within the chip, the prescaler S and the entire chip are in their reset states. When the level on the $\overline{\text{RES}}$ pin reaches the specified value, the prescaler S is released from its reset state and it starts counting. The OVF signal is generated to release the internal reset signal after the prescaler S has counted 131,072 clock (ϕ) cycles. The noise cancellation circuit of approximately 100 ns is incorporated to prevent the incorrect operation of the chip by noise on the $\overline{\text{RES}}$ pin.

To achieve stable operation of this LSI, the power supply needs to rise to its full level and settle within the specified time. The maximum time required for the power supply to rise and settle after power has been supplied (t_{PWON}) is determined by the oscillation frequency (f_{OSC}) and capacitance which is connected to $\overline{\text{RES}}$ pin ($C_{\overline{\text{RES}}}$). If t_{PWON} means the time required to reach 90 % of power supply voltage, the power supply circuit should be designed to satisfy the following formula.

$$t_{\text{PWON}} \text{ (ms)} \leq 90 \times C_{\overline{\text{RES}}} \text{ (\mu F)} + 162/f_{\text{OSC}} \text{ (MHz)}$$

$$(t_{\text{PWON}} \leq 3000 \text{ ms, } C_{\overline{\text{RES}}} \geq 0.22 \text{ \mu F, and } f_{\text{OSC}} = 10 \text{ in 2-MHz to 10-MHz operation)}$$

Note that the power supply voltage (V_{CC}) must fall below $V_{\text{POR}} = 100 \text{ mV}$ and rise after charge on the $\overline{\text{RES}}$ pin is removed. To remove charge on the $\overline{\text{RES}}$ pin, it is recommended that the diode should be placed near V_{CC} . If the power supply voltage (V_{CC}) rises from the point above V_{POR} , a power-on reset may not occur.

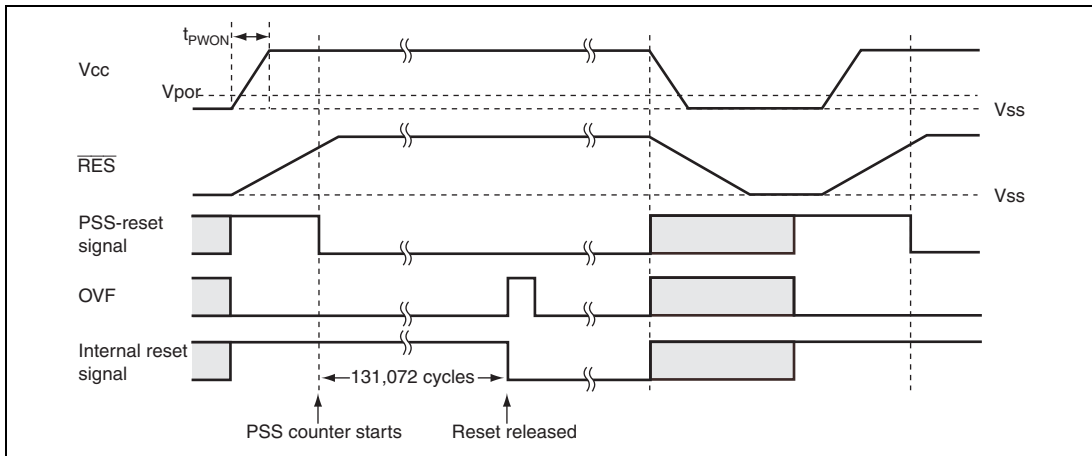

Figure 18.2 Operational Timing of Power-On Reset Circuit

18.3.2 Low-Voltage Detection Circuit

LVDR (Reset by Low Voltage Detect) Circuit:

Figure 18.3 shows the timing of the LVDR function. The LVDR enters the module-standby state after a power-on reset is canceled. To operate the LVDR, set the LVDE bit in LVDCR to 1, wait for $50\ \mu\text{s}$ (t_{LVDRON}) until the reference voltage and the low-voltage-detection power supply have stabilized by a software timer, etc., then set the LVDRE bit in LVDCR to 1. After that, the output settings of ports must be made. To cancel the low-voltage detection circuit, first the LVDRE bit should be cleared to 0 and then the LVDE bit should be cleared to 0. The LVDE and LVDRE bits must not be cleared to 0 simultaneously because incorrect operation may occur.

When the power-supply voltage falls below the V_{reset} voltage (typ. = 2.3 V or 3.6 V), the LVDR clears the $\overline{\text{LVDRES}}$ signal to 0, and resets the prescaler S. The low-voltage detection reset state remains in place until a power-on reset is generated. When the power-supply voltage rises above the V_{reset} voltage again, the prescaler S starts counting. It counts 131,072 clock (ϕ) cycles, and then releases the internal reset signal. In this case, the LVDE, LVDSEL, and LVDRE bits in LVDCR are not initialized.

Note that if the power supply voltage (V_{cc}) falls below $V_{\text{LVDRmin}} = 1.0\ \text{V}$ and then rises from that point, the low-voltage detection reset may not occur.

If the power supply voltage (V_{cc}) falls below $V_{\text{por}} = 100\ \text{mV}$, a power-on reset occurs.

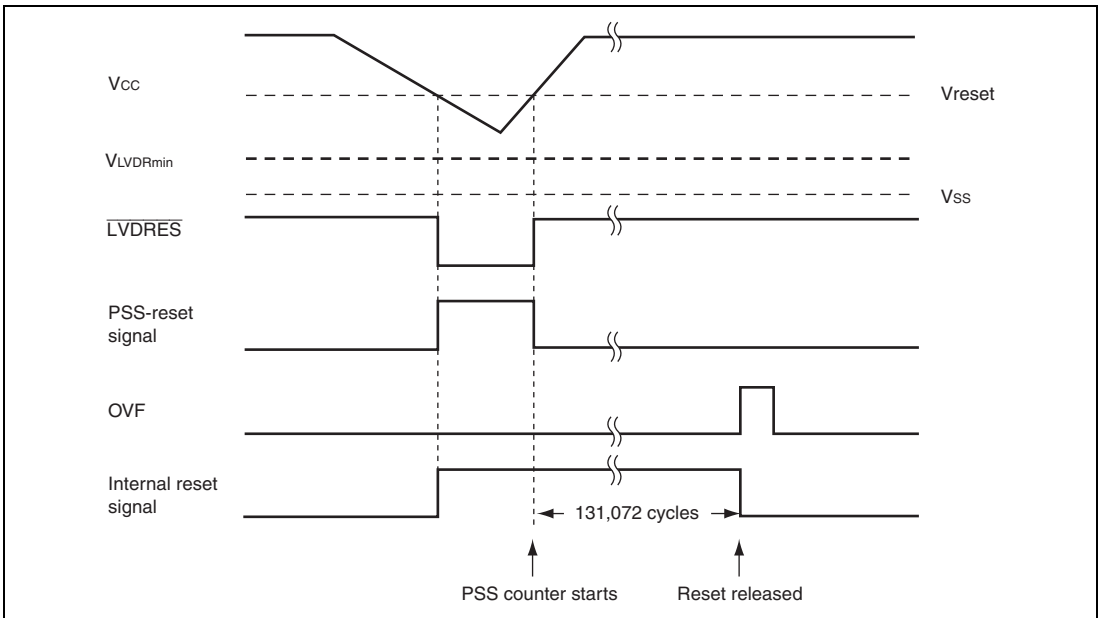

Figure 18.3 Operational Timing of LVDR Circuit

LVDI (Interrupt by Low Voltage Detect) Circuit:

Figure 18.4 shows the timing of LVDI functions. The LVDI enters the module-standby state after a power-on reset is canceled. To operate the LVDI, set the LVDE bit in LVDCR to 1, wait for 50 μs ($t_{\text{LV DON}}$) until the reference voltage and the low-voltage-detection power supply have stabilized by a software timer, etc., then set the LVDDE and LVDUE bits in LVDCR to 1. After that, the output settings of ports must be made. To cancel the low-voltage detection circuit, first the LVDDE and LVDUE bits should all be cleared to 0 and then the LVDE bit should be cleared to 0. The LVDE bit must not be cleared to 0 at the same timing as the LVDDE and LVDUE bits because incorrect operation may occur.

When the power-supply voltage falls below $V_{\text{int}}(D)$ (typ. = 3.7 V) voltage, the LVDI clears the $\overline{\text{LVDINT}}$ signal to 0 and the LVDDF bit in LVDSR is set to 1. If the LVDDE bit is 1 at this time, an IRQ0 interrupt request is simultaneously generated. In this case, the necessary data must be saved in the external EEPROM, etc, and a transition must be made to standby mode or subsleep mode. Until this processing is completed, the power supply voltage must be higher than the lower limit of the guaranteed operating voltage.

When the power-supply voltage does not fall below V_{reset1} (typ. = 2.3 V) voltage but rises above $V_{\text{int}}(U)$ (typ. = 4.0 V) voltage, the LVDI sets the $\overline{\text{LVDINT}}$ signal to 1. If the LVDUE bit is 1 at

this time, the LVDUF bit in LVDSR is set to 1 and an IRQ0 interrupt request is simultaneously generated.

If the power supply voltage (V_{cc}) falls below V_{reset1} (typ. = 2.3 V) voltage, the LVDR function is performed.

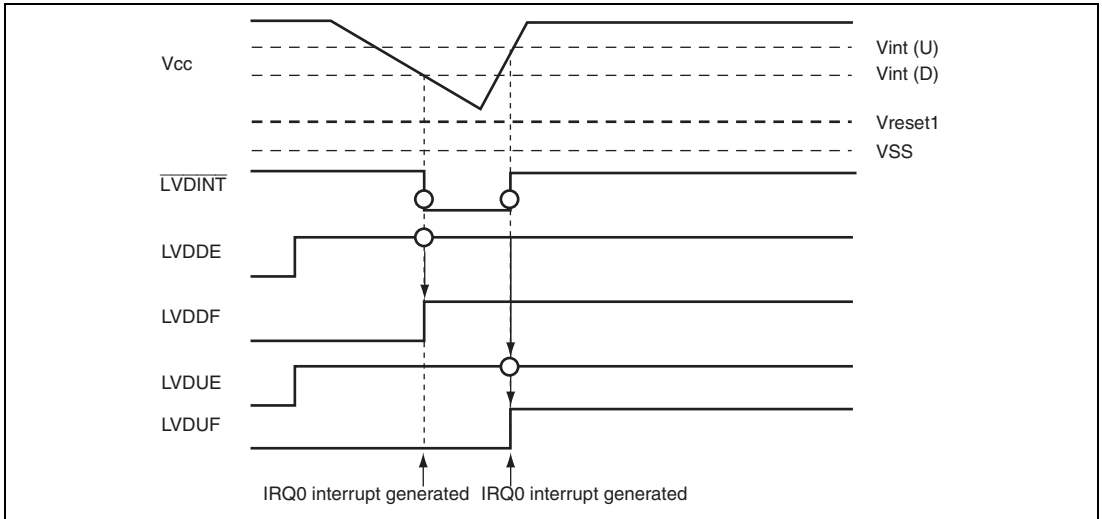

Figure 18.4 Operational Timing of LVDI Circuit

Procedures for Clearing Settings when Using LVDR and LVDI:

To operate or release the low-voltage detection circuit normally, follow the procedure described below. Figure 18.5 shows the timing for the operation and release of the low-voltage detection circuit.

1. To operate the low-voltage detection circuit, set the LVDE bit in LVDCR to 1.
2. Wait for $50\ \mu\text{s}$ ($t_{\text{LV DON}}$) until the reference voltage and the low-voltage-detection power supply have stabilized by a software timer, etc. Then, clear the LVDDF and LVDUF bits in LVDSR to 0 and set the LVDRE, LVDDE, and LVDUE bits in LVDCR to 1, as required.
3. To release the low-voltage detection circuit, start by clearing all of the LVDRE, LVDDE, and LVDUE bits to 0. Then clear the LVDE bit to 0. The LVDE bit must not be cleared to 0 at the same timing as the LVDRE, LVDDE, and LVDUE bits because incorrect operation may occur.

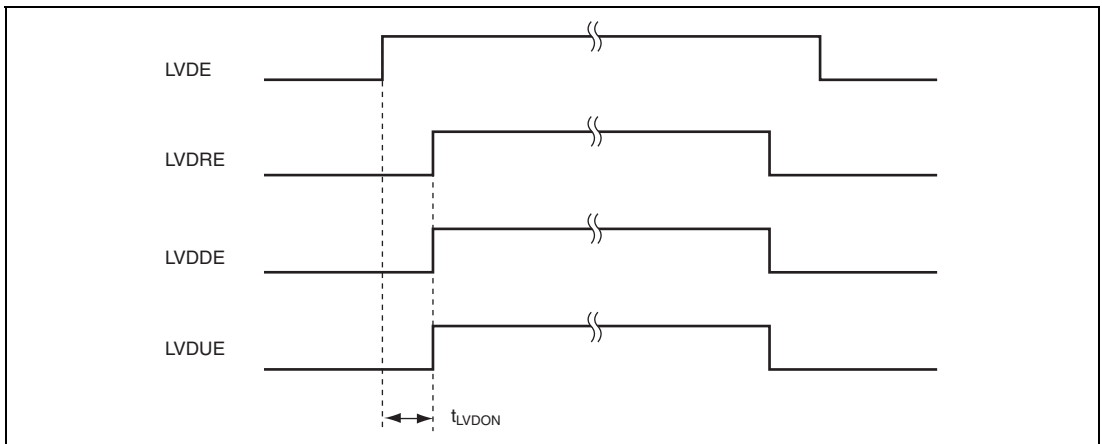

Figure 18.5 Timing for Operation/Release of Low-Voltage Detection Circuit

Section 19 Power Supply Circuit

This LSI incorporates an internal power supply step-down circuit. Use of this circuit enables the internal power supply to be fixed at a constant level of approximately 3.0 V, independently of the voltage of the power supply connected to the external V_{CC} pin. As a result, the current consumed when an external power supply is used at 3.0 V or above can be held down to virtually the same low level as when used at approximately 3.0 V. If the external power supply is 3.0 V or below, the internal voltage will be practically the same as the external voltage. It is, of course, also possible to use the same level of external power supply voltage and internal power supply voltage without using the internal power supply step-down circuit.

19.1 When Using Internal Power Supply Step-Down Circuit

Connect the external power supply to the V_{CC} pin, and connect a capacitance of approximately 0.1 μF between V_{CL} and V_{SS} , as shown in figure 19.1. The internal step-down circuit is made effective simply by adding this external circuit. In the external circuit interface, the external power supply voltage connected to V_{CC} and the GND potential connected to V_{SS} are the reference levels. For example, for port input/output levels, the V_{CC} level is the reference for the high level, and the V_{SS} level is that for the low level. The A/D converter analog power supply is not affected by the internal step-down circuit.

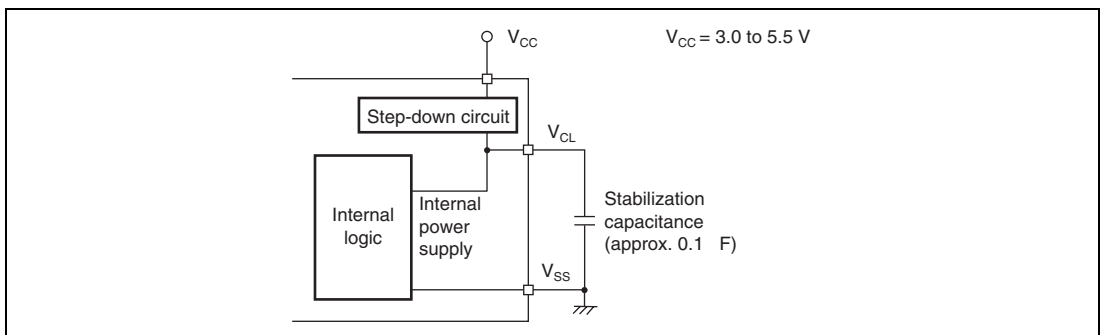

Figure 19.1 Power Supply Connection when Internal Step-Down Circuit is Used

19.2 When Not Using Internal Power Supply Step-Down Circuit

When the internal power supply step-down circuit is not used, connect the external power supply to the V_{CL} pin and V_{CC} pin, as shown in figure 19.2. The external power supply is then input directly to the internal power supply. The permissible range for the power supply voltage is 3.0 V to 3.6 V. Operation cannot be guaranteed if a voltage outside this range (less than 3.0 V or more than 3.6 V) is input.

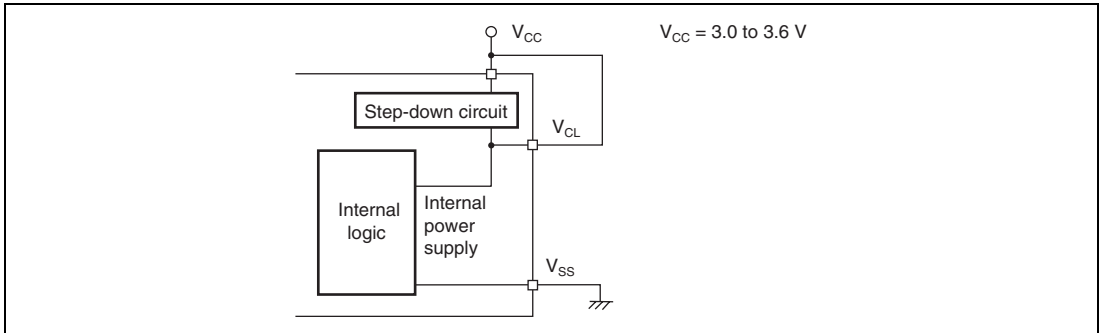

Figure 19.2 Power Supply Connection when Internal Step-Down Circuit is Not Used

Section 20 List of Registers

The register list gives information on the on-chip I/O register addresses, how the register bits are configured, and the register states in each operating mode. The information is given as shown below.

1. Register addresses (address order)

- Registers are listed from the lower allocation addresses.
- The symbol — in the register-name column represents a reserved address or range of reserved addresses.

Do not attempt to access reserved addresses.

- When the address is 16-bit wide, the address of the upper byte is given in the list.
- Registers are classified by functional modules.
- The data bus width is indicated.
- The number of access states is indicated.

2. Register bits

- Bit configurations of the registers are described in the same order as the register addresses.
- Reserved bits are indicated by — in the bit name column.
- When registers consist of 16 bits, bits are described from the MSB side.

3. Register states in each operating mode

- Register states are described in the same order as the register addresses.
- The register states described here are for the basic operating modes. If there is a specific reset for an on-chip peripheral module, refer to the section on that on-chip peripheral module.

20.1 Register Addresses (Address Order)

The data-bus width column indicates the number of bits. The access-state column shows the number of states of the selected basic clock that is required for access to the register.

Note: Access to undefined or reserved addresses should not take place. Correct operation of the access itself or later operations is not guaranteed when such a register is accessed.

| Register Name | Abbreviation | Bit No | Address | Module Name | Data Bus Width | Access State |
|--|--------------|--------|------------------|--------------------|------------------|--------------|
| — | — | — | H'F000 to H'F72F | — | — | — |
| Low-voltage detection control register | LVDCR | 8 | H'F730 | LVDC* ¹ | 8 | 2 |
| Low-voltage detection status register | LVDSR | 8 | H'F731 | LVDC* ¹ | 8 | 2 |
| — | — | — | H'F732 to H'F747 | — | — | — |
| I ² C bus control register 1 | ICCR1 | 8 | H'F748 | IIC2 | 8 | 2 |
| I ² C bus control register 2 | ICCR2 | 8 | H'F749 | IIC2 | 8 | 2 |
| I ² C bus mode register | ICMR | 8 | H'F74A | IIC2 | 8 | 2 |
| I ² C bus interrupt enable register | ICIER | 8 | H'F74B | IIC2 | 8 | 2 |
| I ² C bus status register | ICSR | 8 | H'F74C | IIC2 | 8 | 2 |
| Slave address register | SAR | 8 | H'F74D | IIC2 | 8 | 2 |
| I ² C bus transmit data register | ICDRT | 8 | H'F74E | IIC2 | 8 | 2 |
| I ² C bus receive data register | ICDRR | 8 | H'F74F | IIC2 | 8 | 2 |
| — | — | — | H'F750 to H'FF7F | — | — | — |
| Timer mode register W | TMRW | 8 | H'FF80 | Timer W | 8 | 2 |
| Timer control register W | TCRW | 8 | H'FF81 | Timer W | 8 | 2 |
| Timer interrupt enable register W | TIERW | 8 | H'FF82 | Timer W | 8 | 2 |
| Timer status register W | TSRW | 8 | H'FF83 | Timer W | 8 | 2 |
| Timer I/O control register 0 | TIOR0 | 8 | H'FF84 | Timer W | 8 | 2 |
| Timer I/O control register 1 | TIOR1 | 8 | H'FF85 | Timer W | 8 | 2 |
| Timer counter | TCNT | 16 | H'FF86 | Timer W | 16* ² | 2 |
| General register A | GRA | 16 | H'FF88 | Timer W | 16* ² | 2 |

| Register Name | Abbreviation | Bit No | Address | Module Name | Data Bus Width | Access State |
|-------------------------------------|--------------|--------|------------------|---------------|------------------|--------------|
| General register B | GRB | 16 | H'FF8A | Timer W | 16* ² | 2 |
| General register C | GRC | 16 | H'FF8C | Timer W | 16* ² | 2 |
| General register D | GRD | 16 | H'FF8E | Timer W | 16* ² | 2 |
| Flash memory control register 1 | FLMCR1 | 8 | H'FF90 | ROM | 8 | 2 |
| Flash memory control register 2 | FLMCR2 | 8 | H'FF91 | ROM | 8 | 2 |
| Flash memory power control register | FLPWCR | 8 | H'FF92 | ROM | 8 | 2 |
| Erase block register 1 | EBR1 | 8 | H'FF93 | ROM | 8 | 2 |
| — | — | — | H'FF94 to H'FF9A | — | — | — |
| Flash memory enable register | FENR | 8 | H'FF9B | ROM | 8 | 2 |
| — | — | — | H'FF9C to H'FF9F | — | — | — |
| Timer control register V0 | TCRV0 | 8 | H'FFA0 | Timer V | 8 | 3 |
| Timer control/status register V | TCSR V | 8 | H'FFA1 | Timer V | 8 | 3 |
| Timer constant register A | TCORA | 8 | H'FFA2 | Timer V | 8 | 3 |
| Timer constant register B | TCORB | 8 | H'FFA3 | Timer V | 8 | 3 |
| Timer counter V | TCNTV | 8 | H'FFA4 | Timer V | 8 | 3 |
| Timer control register V1 | TCRV1 | 8 | H'FFA5 | Timer V | 8 | 3 |
| Timer mode register A | TMA | 8 | H'FFA6 | Timer A | 8 | 2 |
| Timer counter A | TCA | 8 | H'FFA7 | Timer A | 8 | 2 |
| Serial mode register | SMR | 8 | H'FFA8 | SCI3 | 8 | 3 |
| Bit rate register | BRR | 8 | H'FFA9 | SCI3 | 8 | 3 |
| Serial control register 3 | SCR3 | 8 | H'FFAA | SCI3 | 8 | 3 |
| Transmit data register | TDR | 8 | H'FFAB | SCI3 | 8 | 3 |
| Serial status register | SSR | 8 | H'FFAC | SCI3 | 8 | 3 |
| Receive data register | RDR | 8 | H'FFAD | SCI3 | 8 | 3 |
| — | — | — | H'FFAE, H'FFAF | — | — | — |
| A/D data register A | ADDRA | 16 | H'FFB0 | A/D converter | 8 | 3 |

| Register Name | Abbreviation | Bit No | Address | Module Name | Data Bus Width | Access State |
|----------------------------------|--------------|--------|------------------|-------------------|----------------|--------------|
| A/D data register B | ADDRB | 16 | H'FFB2 | A/D converter | 8 | 3 |
| A/D data register C | ADDRC | 16 | H'FFB4 | A/D converter | 8 | 3 |
| A/D data register D | ADDRD | 16 | H'FFB6 | A/D converter | 8 | 3 |
| A/D control/status register | ADCSR | 8 | H'FFB8 | A/D converter | 8 | 3 |
| A/D control register | ADCR | 8 | H'FFB9 | A/D converter | 8 | 3 |
| — | — | — | H'FFBA to H'FFBF | — | — | — |
| Timer control/status register WD | TCSRWD | 8 | H'FFC0 | WDT* ³ | 8 | 2 |
| Timer counter WD | TCWD | 8 | H'FFC1 | WDT* ³ | 8 | 2 |
| Timer mode register WD | TMWD | 8 | H'FFC2 | WDT* ³ | 8 | 2 |
| — | — | — | H'FFC3 | — | — | — |
| — | — | — | H'FFC4 to H'FFC7 | — | — | — |
| Address break control register | ABRKCR | 8 | H'FFC8 | Address break | 8 | 2 |
| Address break status register | ABRKSR | 8 | H'FFC9 | Address break | 8 | 2 |
| Break address register H | BARH | 8 | H'FFCA | Address break | 8 | 2 |
| Break address register L | BARL | 8 | H'FFCB | Address break | 8 | 2 |
| Break data register H | BDRH | 8 | H'FFCC | Address break | 8 | 2 |
| Break data register L | BDRL | 8 | H'FFCD | Address break | 8 | 2 |
| — | — | — | H'FFCE, H'FFCF | — | — | — |

| Register Name | Abbreviation | Bit No | Address | Module Name | Data Bus Width | Access State |
|---------------------------------|--------------|--------|---------------------|-------------|----------------|--------------|
| Port pull-up control register 1 | PUCR1 | 8 | H'FFD0 | I/O port | 8 | 2 |
| Port pull-up control register 5 | PUCR5 | 8 | H'FFD1 | I/O port | 8 | 2 |
| — | — | — | H'FFD2, H'FFD3 | I/O port | — | — |
| Port data register 1 | PDR1 | 8 | H'FFD4 | I/O port | 8 | 2 |
| Port data register 2 | PDR2 | 8 | H'FFD5 | I/O port | 8 | 2 |
| — | — | 8 | H'FFD6, H'FFD7 | I/O port | — | — |
| Port data register 5 | PDR5 | 8 | H'FFD8 | I/O port | 8 | 2 |
| — | — | — | H'FFD9 | I/O port | — | — |
| Port data register 7 | PDR7 | 8 | H'FFDA | I/O port | 8 | 2 |
| Port data register 8 | PDR8 | 8 | H'FFDB | I/O port | 8 | 2 |
| — | — | — | H'FFDC | I/O port | — | — |
| Port data register B | PDRB | 8 | H'FFDD | I/O port | 8 | 2 |
| — | — | — | H'FFDE, H'FFDF | I/O port | — | — |
| Port mode register 1 | PMR1 | 8 | H'FFE0 | I/O port | 8 | 2 |
| Port mode register 5 | PMR5 | 8 | H'FFE1 | I/O port | 8 | 2 |
| — | — | — | H'FFE2, H'FFE3 | I/O port | — | — |
| Port control register 1 | PCR1 | 8 | H'FFE4 | I/O port | 8 | 2 |
| Port control register 2 | PCR2 | 8 | H'FFE5 | I/O port | 8 | 2 |
| — | — | — | H'FFE6, H'FFE7 | I/O port | — | — |
| Port control register 5 | PCR5 | 8 | H'FFE8 | I/O port | 8 | 2 |
| — | — | — | H'FFE9 | I/O port | — | — |
| Port control register 7 | PCR7 | 8 | H'FFEA | I/O port | 8 | 2 |
| Port control register 8 | PCR8 | 8 | H'FFEB | I/O port | 8 | 2 |
| — | — | — | H'FFEC to H'FFEF | I/O port | — | — |

| Register Name | Abbreviation | Bit No | Address | Module Name | Data Bus Width | Access State |
|-----------------------------------|--------------|--------|------------------|-------------|----------------|--------------|
| System control register 1 | SYSCR1 | 8 | H'FFF0 | Power-down | 8 | 2 |
| System control register 2 | SYSCR2 | 8 | H'FFF1 | Power-down | 8 | 2 |
| Interrupt edge select register 1 | IEGR1 | 8 | H'FFF2 | Interrupts | 8 | 2 |
| Interrupt edge select register 2 | IEGR2 | 8 | H'FFF3 | Interrupts | 8 | 2 |
| Interrupt enable register 1 | IENR1 | 8 | H'FFF4 | Interrupts | 8 | 2 |
| — | — | — | H'FFF5 | I/O port | — | — |
| Interrupt flag register 1 | IRR1 | 8 | H'FFF6 | Interrupts | 8 | 2 |
| — | — | — | H'FFE7 | I/O port | — | — |
| Wake-up interrupt flag register | IWPR | 8 | H'FFF8 | Interrupts | 8 | 2 |
| Module standby control register 1 | MSTCR1 | 8 | H'FFF9 | Power-down | 8 | 2 |
| — | — | — | H'FFFA to H'FFFF | — | — | — |

- EEPROM

| Register Name | Abbreviation | Bit No | Address | Module Name | Data Bus Width | Access State |
|-------------------------------|--------------|--------|---------|-------------|----------------|--------------|
| EEPROM slave address register | — | 8 | H'FF09 | EEPROM | — | — |
| EEPROM key register | EKR | 8 | H'FF10 | EEPROM | — | — |

- Notes:
1. LVDC: Low-voltage detection circuits (optional)
 2. Only word access can be used.
 3. WDT: Watchdog timer

20.2 Register Bits

The addresses and bit names of the registers in the on-chip peripheral modules are listed below. The 16-bit register is indicated in two rows, 8 bits for each row.

| Register Name | Bit 7 | Bit 6 | Bit 5 | Bit 4 | Bit 3 | Bit 2 | Bit 1 | Bit 0 | Module Name |
|---------------|--------|--------|--------|--------|--------|--------|--------|--------|--------------------------|
| — | — | — | — | — | — | — | — | — | — |
| LVDCR | LVDE | — | — | — | LVDSEL | LVDRE | LVDDE | LVDUE | LVDC |
| LVDSR | — | — | — | — | — | — | LVDDF | LVDUF | (optional)* ¹ |
| — | — | — | — | — | — | — | — | — | — |
| ICCR1 | ICE | RCVD | MST | TRS | CKS3 | CKS2 | CKS1 | CKS0 | IIC2 |
| ICCR2 | BBSY | SCP | SDAO | SDAOP | SCKO | — | IICRST | — | |
| ICMR | MLS | WAIT | — | — | BCWP | BC2 | BC1 | BC0 | |
| ICIER | TIE | TEIE | RIE | NAKIE | STIE | ACKE | ACKBR | ACKBT | |
| ICSR | TDRE | TEND | RDRF | NACKF | STOP | AL/OVE | AAS | ADZ | |
| SAR | SVA6 | SVA5 | SVA4 | SVA3 | SVA2 | SVA1 | SVA0 | FS | |
| ICDRT | ICDRT7 | ICDRT6 | ICDRT5 | ICDRT4 | ICDRT3 | ICDRT2 | ICDRT1 | ICDRT0 | |
| ICDRR | ICDRR7 | ICDRR6 | ICDRR5 | ICDRR4 | ICDRR3 | ICDRR2 | ICDRR1 | ICDRR0 | |
| — | — | — | — | — | — | — | — | — | — |
| TMRW | CTS | — | BUFEB | BUFEA | — | PWMD | PWMC | PWMB | Timer W |
| TCRW | CCLR | CKS2 | CKS1 | CKS0 | TOD | TOC | TOB | TOA | |
| TIERW | OVIE | — | — | — | IMIED | IMIEC | IMIEB | IMIEA | |
| TSRW | OVF | — | — | — | IMFD | IMFC | IMFB | IMFA | |
| TIOR0 | — | IOB2 | IOB1 | IOB0 | — | IOA2 | IOA1 | IOA0 | |
| TIOR1 | — | IOD2 | IOD1 | IOD0 | — | IOC2 | IOC1 | IOC0 | |
| TCNT | TCNT15 | TCNT14 | TCNT13 | TCNT12 | TCNT11 | TCNT10 | TCNT9 | TCNT8 | |
| | TCNT7 | TCNT6 | TCNT5 | TCNT4 | TCNT3 | TCNT2 | TCNT1 | TCNT0 | |
| GRA | GRA15 | GRA14 | GRA13 | GRA12 | GRA11 | GRA10 | GRA9 | GRA8 | |
| | GRA7 | GRA6 | GRA5 | GRA4 | GRA3 | GRA2 | GRA1 | GRA0 | |
| GRB | GRB15 | GRB14 | GRB13 | GRB12 | GRB11 | GRB10 | GRB9 | GRB8 | |
| | GRB7 | GRB6 | GRB5 | GRB4 | GRB3 | GRB2 | GRB1 | GRB0 | |
| GRC | GRC15 | GRC14 | GRC13 | GRC12 | GRC11 | GRC10 | GRC9 | GRC8 | |
| | GRC7 | GRC6 | GRC5 | GRC4 | GRC3 | GRC2 | GRC1 | GRC0 | |
| GRD | GRD15 | GRD14 | GRD13 | GRD12 | GRD11 | GRD10 | GRD9 | GRD8 | |
| | GRD7 | GRD6 | GRD5 | GRD4 | GRD3 | GRD2 | GRD1 | GRD0 | |

| Register Name | Bit 7 | Bit 6 | Bit 5 | Bit 4 | Bit 3 | Bit 2 | Bit 1 | Bit 0 | Module Name |
|---------------|--------|--------|--------|--------|--------|--------|--------|--------|---------------|
| FLMCR1 | — | SWE | ESU | PSU | EV | PV | E | P | ROM |
| FLMCR2 | FLER | — | — | — | — | — | — | — | |
| FLPWCR | PDWND | — | — | — | — | — | — | — | |
| EBR1 | — | — | — | EB4 | EB3 | EB2 | EB1 | EB0 | |
| FENR | FLSHE | — | — | — | — | — | — | — | |
| TCRV0 | CMIEB | CMIEA | OVIE | CCLR1 | CCLR0 | CKS2 | CKS1 | CKS0 | Timer V |
| TCSRv | CMFB | CMFA | OVF | — | OS3 | OS2 | OS1 | OS0 | |
| TCORA | TCORA7 | TCORA6 | TCORA5 | TCORA4 | TCORA3 | TCORA2 | TCORA1 | TCORA0 | |
| TCORB | TCORB7 | TCORB6 | TCORB5 | TCORB4 | TCORB3 | TCORB2 | TCORB1 | TCORB0 | |
| TCNTV | TCNTV7 | TCNTV6 | TCNTV5 | TCNTV4 | TCNTV3 | TCNTV2 | TCNTV1 | TCNTV0 | |
| TCRV1 | — | — | — | TVEG1 | TVEG0 | TRGE | — | ICKS0 | |
| TMA | TMA7 | TMA6 | TMA5 | — | TMA3 | TMA2 | TMA1 | TMA0 | Timer A |
| TCA | TCA7 | TCA6 | TCA5 | TCA4 | TCA3 | TCA2 | TCA1 | TCA0 | |
| SMR | COM | CHR | PE | PM | STOP | MP | CKS1 | CKS0 | SCI3 |
| BRR | BRR7 | BRR6 | BRR5 | BRR4 | BRR3 | BRR2 | BRR1 | BRR0 | |
| SCR3 | TIE | RIE | TE | RE | MPIE | TEIE | CKE1 | CKE0 | |
| TDR | TDR7 | TDR6 | TDR5 | TDR4 | TDR3 | TDR2 | TDR1 | TDR0 | |
| SSR | TDRE | RDRF | OER | FER | PER | TEND | MPBR | MPBT | |
| RDR | RDR7 | RDR6 | RDR5 | RDR4 | RDR3 | RDR2 | RDR1 | RDR0 | |
| ADDRA | AD9 | AD8 | AD7 | AD6 | AD5 | AD4 | AD3 | AD2 | A/D converter |
| | AD1 | AD0 | — | — | — | — | — | — | |
| ADDRB | AD9 | AD8 | AD7 | AD6 | AD5 | AD4 | AD3 | AD2 | |
| | AD1 | AD0 | — | — | — | — | — | — | |
| ADDRC | AD9 | AD8 | AD7 | AD6 | AD5 | AD4 | AD3 | AD2 | |
| | AD1 | AD0 | — | — | — | — | — | — | |
| ADDRD | AD9 | AD8 | AD7 | AD6 | AD5 | AD4 | AD3 | AD2 | |
| | AD1 | AD0 | — | — | — | — | — | — | |
| ADCSR | ADF | ADIE | ADST | SCAN | CKS | CH2 | CH1 | CH0 | |
| ADCR | TRGE | — | — | — | — | — | — | — | |
| — | — | — | — | — | — | — | — | — | — |
| TCSRWD | B6WI | TCWE | B4WI | TCSRWE | B2WI | WDON | B0WI | WRST | WDT*2 |
| TCWD | TCWD7 | TCWD6 | TCWD5 | TCWD4 | TCWD3 | TCWD2 | TCWD1 | TCWD0 | |

| Register Name | Bit 7 | Bit 6 | Bit 5 | Bit 4 | Bit 3 | Bit 2 | Bit 1 | Bit 0 | Module Name |
|---------------|---------|---------|--------|--------|--------|--------|--------|--------|---------------|
| TMWD | — | — | — | — | CKS3 | CKS2 | CKS1 | CKS0 | WDT*2 |
| — | — | — | — | — | — | — | — | — | — |
| ABRKCR | RTINTE | CSEL1 | CSEL0 | ACMP2 | ACMP1 | ACMP0 | DCMP1 | DCMP0 | Address break |
| ABRKSR | ABIF | ABIE | — | — | — | — | — | — | |
| BARH | BARH7 | BARH6 | BARH5 | BARH4 | BARH3 | BARH2 | BARH1 | BARH0 | |
| BARL | BARL7 | BARL6 | BARL5 | BARL4 | BARL3 | BARL2 | BARL1 | BARL0 | |
| BDRH | BDRH7 | BDRH6 | BDRH5 | BDRH4 | BDRH3 | BDRH2 | BDRH1 | BDRH0 | |
| BDRL | BDRL7 | BDRL6 | BDRL5 | BDRL4 | BDRL3 | BDRL2 | BDRL1 | BDRL0 | |
| — | — | — | — | — | — | — | — | — | — |
| PUCR1 | PUCR17 | PUCR16 | PUCR15 | PUCR14 | — | PUCR12 | PUCR11 | PUCR10 | I/O port |
| PUCR5 | — | — | PUCR55 | PUCR54 | PUCR53 | PUCR52 | PUCR51 | PUCR50 | |
| PDR1 | P17 | P16 | P15 | P14 | — | P12 | P11 | P10 | |
| PDR2 | — | — | — | — | — | P22 | P21 | P20 | |
| PDR5 | P57*3 | P56*3 | P55 | P54 | P53 | P52 | P51 | P50 | |
| PDR7 | — | P76 | P75 | P74 | — | — | — | — | |
| PDR8 | P87 | P86 | P85 | P84 | P83 | P82 | P81 | P80 | |
| PDRB | PB7 | PB6 | PB5 | PB4 | PB3 | PB2 | PB1 | PB0 | |
| PMR1 | IRQ3 | IRQ2 | IRQ1 | IRQ0 | — | — | TXD | TMOW | |
| PMR5 | — | — | WKP5 | WKP4 | WKP3 | WKP2 | WKP1 | WKP0 | |
| PCR1 | PCR17 | PCR16 | PCR15 | PCR14 | — | PCR12 | PCR11 | PCR10 | |
| PCR2 | — | — | — | — | — | PCR22 | PCR21 | PCR20 | |
| PCR5 | PCR57*3 | PCR56*3 | PCR55 | PCR54 | PCR53 | PCR52 | PCR51 | PCR50 | |
| PCR7 | — | PCR76 | PCR75 | PCR74 | — | — | — | — | |
| PCR8 | PCR87 | PCR86 | PCR85 | PCR84 | PCR83 | PCR82 | PCR81 | PCR80 | |
| SYSCR1 | SSBY | STS2 | STS1 | STS0 | NESEL | — | — | — | Power-down |
| SYSCR2 | SMSSEL | LSON | DTON | MA2 | MA1 | MA0 | SA1 | SA0 | |
| IEGR1 | NMIEG | — | — | — | IEG3 | IEG2 | IEG1 | IEG0 | Interrupts |
| IEGR2 | — | — | WPEG5 | WPEG4 | WPEG3 | WPEG2 | WPEG1 | WPEG0 | |
| IENR1 | IENDT | IENTA | IENWP | — | IEN3 | IEN2 | IEN1 | IEN0 | |
| IRR1 | IRRDT | IRRATA | — | — | IRRI3 | IRRI2 | IRRI1 | IRRI0 | |
| IWPR | — | — | IWPF5 | IWPF4 | IWPF3 | IWPF2 | IWPF1 | IWPF0 | |
| MSTCR1 | — | MSTIIC | MSTS3 | MSTAD | MSTWD | MSTTW | MSTTV | MSTTA | Power-down |
| — | — | — | — | — | — | — | — | — | |

• EEPROM

| Register Name | Bit 7 | Bit 6 | Bit 5 | Bit 4 | Bit 3 | Bit 2 | Bit 1 | Bit 0 | Module Name |
|---------------|-------|-------|-------|-------|-------|-------|-------|-------|-------------|
| EKR | | | | | | | | | EEPROM |

- Notes:
1. LVDC: Low-voltage detection circuits (optional)
 2. WDT: Watchdog timer
 3. These bits are reserved in the EEPROM stacked F-ZTAT™ and mask-ROM versions.

20.3 Registers States in Each Operating Mode

| Register Name | Reset | Active | Sleep | Subactive | Subsleep | Standby | Module |
|---------------|-------------|--------|-------|-------------|-------------|-------------|--------------------------|
| LVDCR | Initialized | — | — | — | — | — | LVDC |
| LVDSR | Initialized | — | — | — | — | — | (optional)* ¹ |
| ICCR1 | Initialized | — | — | — | — | — | IIC2 |
| ICCR2 | Initialized | — | — | — | — | — | |
| ICMR | Initialized | — | — | — | — | — | |
| ICIER | Initialized | — | — | — | — | — | |
| ICSR | Initialized | — | — | — | — | — | |
| SAR | Initialized | — | — | — | — | — | |
| ICDRT | Initialized | — | — | — | — | — | |
| ICDRR | Initialized | — | — | — | — | — | |
| TMRW | Initialized | — | — | — | — | — | Timer W |
| TCRW | Initialized | — | — | — | — | — | |
| TIERW | Initialized | — | — | — | — | — | |
| TSRW | Initialized | — | — | — | — | — | |
| TIOR0 | Initialized | — | — | — | — | — | |
| TIOR1 | Initialized | — | — | — | — | — | |
| TCNT | Initialized | — | — | — | — | — | |
| GRA | Initialized | — | — | — | — | — | |
| GRB | Initialized | — | — | — | — | — | |
| GRC | Initialized | — | — | — | — | — | |
| GRD | Initialized | — | — | — | — | — | |
| FLMCR1 | Initialized | — | — | Initialized | Initialized | Initialized | ROM |
| FLMCR2 | Initialized | — | — | — | — | — | |
| FLPWCR | Initialized | — | — | — | — | — | |
| EBR1 | Initialized | — | — | Initialized | Initialized | Initialized | |
| FENR | Initialized | — | — | — | — | — | |
| TCRV0 | Initialized | — | — | Initialized | Initialized | Initialized | Timer V |
| TCSRv | Initialized | — | — | Initialized | Initialized | Initialized | |
| TCORA | Initialized | — | — | Initialized | Initialized | Initialized | |
| TCORB | Initialized | — | — | Initialized | Initialized | Initialized | |

| Register Name | Reset | Active | Sleep | Subactive | Subsleep | Standby | Module |
|---------------|-------------|--------|-------|-------------|-------------|-------------|-------------------|
| TCNTV | Initialized | — | — | Initialized | Initialized | Initialized | Timer V |
| TCRV1 | Initialized | — | — | Initialized | Initialized | Initialized | |
| TMA | Initialized | — | — | — | — | — | Timer A |
| TCA | Initialized | — | — | — | — | — | |
| SMR | Initialized | — | — | Initialized | Initialized | Initialized | SCI3 |
| BRR | Initialized | — | — | Initialized | Initialized | Initialized | |
| SCR3 | Initialized | — | — | Initialized | Initialized | Initialized | |
| TDR | Initialized | — | — | Initialized | Initialized | Initialized | |
| SSR | Initialized | — | — | Initialized | Initialized | Initialized | |
| RDR | Initialized | — | — | Initialized | Initialized | Initialized | |
| ADDRA | Initialized | — | — | Initialized | Initialized | Initialized | |
| ADDRB | Initialized | — | — | Initialized | Initialized | Initialized | |
| ADDRC | Initialized | — | — | Initialized | Initialized | Initialized | |
| ADDRD | Initialized | — | — | Initialized | Initialized | Initialized | |
| ADCSR | Initialized | — | — | Initialized | Initialized | Initialized | |
| ADCR | Initialized | — | — | Initialized | Initialized | Initialized | |
| TCSRWD | Initialized | — | — | — | — | — | WDT* ² |
| TCWD | Initialized | — | — | — | — | — | |
| TMWD | Initialized | — | — | — | — | — | |
| ABRKCR | Initialized | — | — | — | — | — | Address Break |
| ABRKSR | Initialized | — | — | — | — | — | |
| BARH | Initialized | — | — | — | — | — | |
| BARL | Initialized | — | — | — | — | — | |
| BDRH | Initialized | — | — | — | — | — | |
| BDRL | Initialized | — | — | — | — | — | |
| PUCR1 | Initialized | — | — | — | — | — | |
| PUCR5 | Initialized | — | — | — | — | — | |
| PDR1 | Initialized | — | — | — | — | — | |
| PDR2 | Initialized | — | — | — | — | — | |
| PDR5 | Initialized | — | — | — | — | — | |
| PDR7 | Initialized | — | — | — | — | — | |
| PDR8 | Initialized | — | — | — | — | — | |
| PDRB | Initialized | — | — | — | — | — | |

| Register Name | Reset | Active | Sleep | Subactive | Subsleep | Standby | Module |
|---------------|-------------|--------|-------|-----------|----------|---------|------------|
| PMR1 | Initialized | — | — | — | — | — | I/O port |
| PMR5 | Initialized | — | — | — | — | — | |
| PCR1 | Initialized | — | — | — | — | — | |
| PCR2 | Initialized | — | — | — | — | — | |
| PCR5 | Initialized | — | — | — | — | — | |
| PCR7 | Initialized | — | — | — | — | — | |
| PCR8 | Initialized | — | — | — | — | — | |
| SYSCR1 | Initialized | — | — | — | — | — | Power-down |
| SYSCR2 | Initialized | — | — | — | — | — | Power-down |
| IEGR1 | Initialized | — | — | — | — | — | Interrupts |
| IEGR2 | Initialized | — | — | — | — | — | Interrupts |
| IENR1 | Initialized | — | — | — | — | — | Interrupts |
| IRR1 | Initialized | — | — | — | — | — | Interrupts |
| IWPR | Initialized | — | — | — | — | — | Interrupts |
| MSTCR1 | Initialized | — | — | — | — | — | Power-down |

- EEPROM

| Register Name | Reset | Active | Sleep | Subactive | Subsleep | Standby | Module |
|---------------|-------|--------|-------|-----------|----------|---------|--------|
| EKR | — | — | — | — | — | — | EEPROM |

Notes: — is not initialized

1. LVDC: Low-voltage detection circuits (optional)
2. WDT: Watchdog timer

Section 21 Electrical Characteristics

21.1 Absolute Maximum Ratings

Table 21.1 Absolute Maximum Ratings

| Item | | Symbol | Value | Unit | Note |
|-----------------------------|---------------------------------|-----------|-------------------------|------|------|
| Power supply voltage | | V_{CC} | -0.3 to +7.0 | V | * |
| Analog power supply voltage | | AV_{CC} | -0.3 to +7.0 | V | |
| Input voltage | Ports other than ports B and X1 | V_{IN} | -0.3 to $V_{CC} + 0.3$ | V | |
| | Port B | | -0.3 to $AV_{CC} + 0.3$ | V | |
| | X1 | | -0.3 to 4.3 | V | |
| Operating temperature | | T_{opr} | -20 to +75 | °C | |
| Storage temperature | | T_{stg} | -55 to +125 | °C | |

Note: * Permanent damage may result if maximum ratings are exceeded. Normal operation should be under the conditions specified in Electrical Characteristics. Exceeding these values can result in incorrect operation and reduced reliability.

21.2 Electrical Characteristics (F-ZTAT™ Version, EEPROM Stacked F-ZTAT™ Version)

21.2.1 Power Supply Voltage and Operating Ranges

Power Supply Voltage and Oscillation Frequency Range

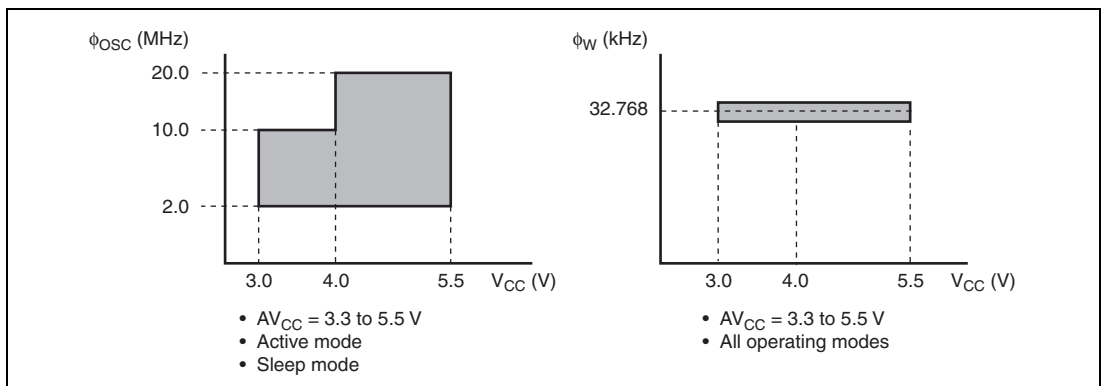

Power Supply Voltage and Operating Frequency Range

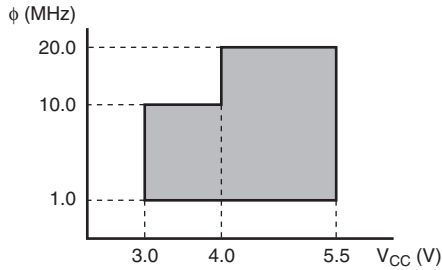

- $AV_{CC} = 3.3$ to 5.5 V
- Active mode
- Sleep mode
(When MA2 in SYSCR2 = 0)

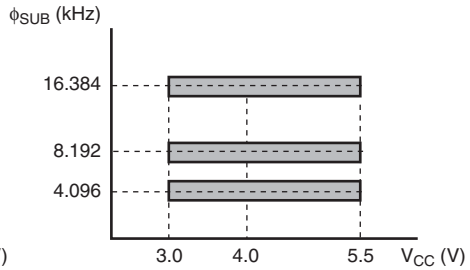

- $AV_{CC} = 3.3$ to 5.5 V
- Subactive mode
- Subsleap mode

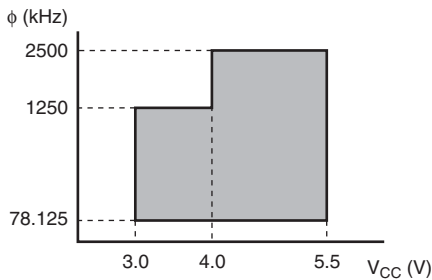

- $AV_{CC} = 3.3$ to 5.5 V
- Active mode
- Sleep mode
(When MA2 in SYSCR2 = 1)

Analog Power Supply Voltage and A/D Converter Accuracy Guarantee Range

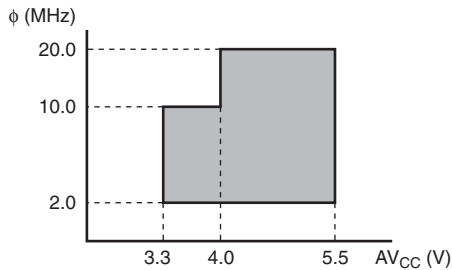

- $V_{CC} = 3.0$ to 5.5 V
- Active mode
- Sleep mode

Range of Power Supply Voltage and Oscillation Frequency when Low-Voltage Detection Circuit is Used

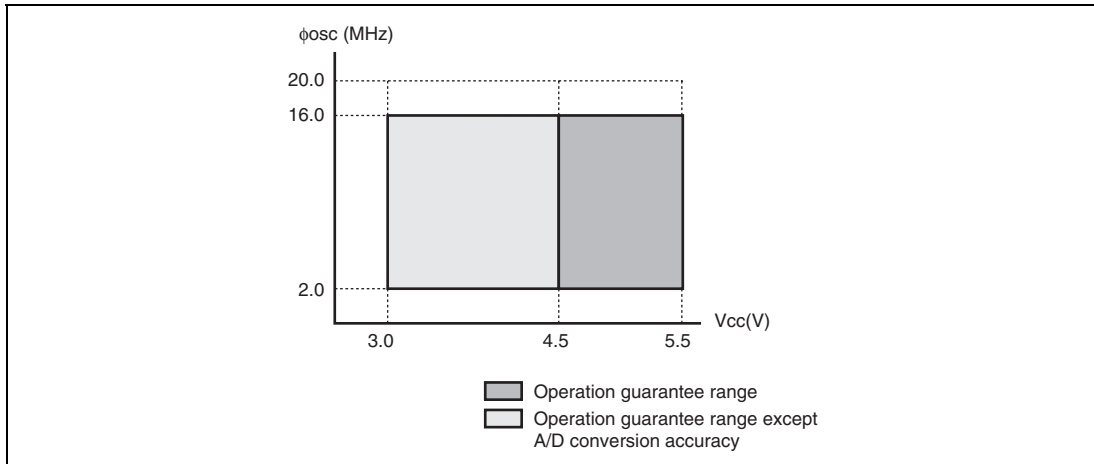

21.2.2 DC Characteristics

Table 21.2 DC Characteristics (1)

$V_{CC} = 3.0$ to 5.5 V, $V_{SS} = 0.0$ V, $T_a = -20$ to $+75^\circ\text{C}$, unless otherwise indicated.

| Item | Symbol | Applicable Pins | Test Condition | Values | | | Unit | Notes |
|--------------------|---------------------------|---|---------------------------|---------------------|----------------|---------------------|------|-------|
| | | | | Min | Typ | Max | | |
| Input high voltage | V_{IH} | RES, NMI, WKP0 to WKP5, IRQ0 to IRQ3, ADTRG, TMRIV, TMCIV, FTCL, FTIOA to FTIOD, SCK3, TRGV | $V_{CC} = 4.0$ to 5.5 V | $V_{CC} \times 0.8$ | — | $V_{CC} + 0.3$ | V | |
| | | | | $V_{CC} \times 0.9$ | — | $V_{CC} + 0.3$ | | |
| | | RXD, SCL, SDA, P10 to P12, P14 to P17, P20 to P22, P50 to P57, P74 to P76, P80 to P87 | $V_{CC} = 4.0$ to 5.5 V | $V_{CC} \times 0.7$ | — | $V_{CC} + 0.3$ | V | |
| | | | | $V_{CC} \times 0.8$ | — | $V_{CC} + 0.3$ | | |
| | | | | $V_{CC} \times 0.7$ | — | $AV_{CC} + 0.3$ | | |
| OSC1 | $V_{CC} = 4.0$ to 5.5 V | $V_{CC} - 0.5$ | — | $V_{CC} + 0.3$ | V | | | |
| | | | $V_{CC} - 0.3$ | — | $V_{CC} + 0.3$ | | | |
| Input low voltage | V_{IL} | RES, NMI, WKP0 to WKP5, IRQ0 to IRQ3, ADTRG, TMRIV, TMCIV, FTCL, FTIOA to FTIOD, SCK3, TRGV | $V_{CC} = 4.0$ to 5.5 V | -0.3 | — | $V_{CC} \times 0.2$ | V | |
| | | | | -0.3 | — | $V_{CC} \times 0.1$ | | |
| | | RXD, SCL, SDA, P10 to P12, P14 to P17, P20 to P22, P50 to P57, P74 to P76, P80 to P87 PB0 to PB7 | $V_{CC} = 4.0$ to 5.5 V | -0.3 | — | $V_{CC} \times 0.3$ | V | |
| | | | | -0.3 | — | $V_{CC} \times 0.2$ | | |
| | | | | -0.3 | — | 0.5 | | |
| OSC1 | $V_{CC} = 4.0$ to 5.5 V | -0.3 | — | 0.3 | V | | | |
| | | | -0.3 | — | 0.3 | | | |

| Item | Symbol | Applicable Pins | Test Condition | Values | | | Unit | Notes | | |
|------------------------------|------------|---|---|----------------|---------------------------|-----|---------|-------|---------|--|
| | | | | Min | Typ | Max | | | | |
| Output high voltage | V_{OH} | P10 to P12, P14 to P17, P20 to P22, P50 to P55, P74 to P76, P80 to P87 | $V_{CC} = 4.0$ to 5.5 V | $V_{CC} - 1.0$ | — | — | V | | | |
| | | | $-I_{OH} = 1.5$ mA | | | | | | | |
| | | P56, P57 | $V_{CC} = 4.0$ to 5.5 V | $V_{CC} - 2.5$ | — | — | V | | | |
| | | | $-I_{OH} = 0.1$ mA | | | | | | | |
| | | | $V_{CC} = 3.0$ to 4.0 V | $V_{CC} - 2.0$ | — | — | | | | |
| | | | $-I_{OH} = 0.1$ mA | | | | | | | |
| Output low voltage | V_{OL} | P10 to P12, P14 to P17, P20 to P22, P50 to P57, P74 to P76 | $V_{CC} = 4.0$ to 5.5 V | — | — | 0.6 | V | | | |
| | | | $V_{IOL} = 1.6$ mA | | | | | | | |
| | | P80 to P87 | $V_{CC} = 4.0$ to 5.5 V | — | — | 1.5 | V | | | |
| | | | $I_{OL} = 20.0$ mA | | | | | | | |
| | | | | | $V_{CC} = 4.0$ to 5.5 V | — | — | 1.0 | | |
| | | | | | $I_{OL} = 10.0$ mA | | | | | |
| | | | | | $V_{CC} = 4.0$ to 5.5 V | — | — | 0.4 | | |
| | | | | | $I_{OL} = 1.6$ mA | | | | | |
| | | | | | $I_{OL} = 0.4$ mA | — | — | 0.4 | | |
| | | SCL, SDA | | | $V_{CC} = 4.0$ to 5.5 V | — | — | 0.6 | V | |
| | | | $I_{OL} = 6.0$ mA | | | | | | | |
| | | | $I_{OL} = 3.0$ mA | — | — | 0.4 | | | | |
| Input/output leakage current | $ I_{IL} $ | OSC1, NMI, WKP0 to WKP5, IRQ0 to IRQ3, ADTRG, TRGV, TMRIV, TMCIV, FTCL, FTIOA to FTIOD, RXD, SCK3, SCL, SDA | $V_{IN} = 0.5$ V to $(V_{CC} - 0.5)$ V | — | — | 1.0 | μ A | | | |
| | | | $V_{IN} = 0.5$ V to $(V_{CC} - 0.5)$ V | — | — | 1.0 | | | μ A | |
| | | PB0 to PB7 | $V_{IN} = 0.5$ V to $(AV_{CC} - 0.5)$ V | — | — | 1.0 | μ A | | | |

| Item | Symbol | Applicable Pins | Test Condition | Values | | | Unit | Notes |
|------------------------------------|--------------|--|--|--------|------|-------|---------------|----------------------|
| | | | | Min | Typ | Max | | |
| Pull-up MOS current | $-I_p$ | P10 to P12, P14 to P17, P50 to P55 | $V_{CC} = 5.0\text{ V},$ $V_{IN} = 0.0\text{ V}$ | 50.0 | — | 300.0 | μA | |
| | | | $V_{CC} = 3.0\text{ V},$ $V_{IN} = 0.0\text{ V}$ | — | 60.0 | — | | Reference value |
| Input capacitance | C_{in} | All input pins except power supply pins | $f = 1\text{ MHz},$ $V_{IN} = 0.0\text{ V},$ $T_a = 25^\circ\text{C}$ | — | — | 15.0 | pF | |
| | | SDA, SCL | | — | — | 25.0 | pF | HD64N3694G |
| Active mode current consumption | I_{OPE1} | V_{CC} | Active mode 1 $V_{CC} = 5.0\text{ V},$ $f_{OSC} = 20\text{ MHz}$ | — | 20.0 | 30.0 | mA | * |
| | | | Active mode 1 $V_{CC} = 3.0\text{ V},$ $f_{OSC} = 10\text{ MHz}$ | — | 8.0 | — | | * Reference value |
| | I_{OPE2} | V_{CC} | Active mode 2 $V_{CC} = 5.0\text{ V},$ $f_{OSC} = 20\text{ MHz}$ | — | 2.0 | 3.0 | mA | * |
| | | | Active mode 2 $V_{CC} = 3.0\text{ V},$ $f_{OSC} = 10\text{ MHz}$ | — | 1.2 | — | | * Reference value |
| Sleep mode current consumption | I_{SLEEP1} | V_{CC} | Sleep mode 1 $V_{CC} = 5.0\text{ V},$ $f_{OSC} = 20\text{ MHz}$ | — | 16.0 | 22.5 | mA | * |
| | | | Sleep mode 1 $V_{CC} = 3.0\text{ V},$ $f_{OSC} = 10\text{ MHz}$ | — | 8.0 | — | | * Reference value |
| | I_{SLEEP2} | V_{CC} | Sleep mode 2 $V_{CC} = 5.0\text{ V},$ $f_{OSC} = 20\text{ MHz}$ | — | 1.8 | 2.7 | mA | * |
| | | | Sleep mode 2 $V_{CC} = 3.0\text{ V},$ $f_{OSC} = 10\text{ MHz}$ | — | 1.2 | — | | * Reference value |
| Subactive mode current consumption | I_{SUB} | V_{CC} | $V_{CC} = 3.0\text{ V}$ 32-kHz crystal resonator ($\phi_{SUB} = \phi_W/2$) | — | 40.0 | 70.0 | μA | * |
| | | | $V_{CC} = 3.0\text{ V}$ 32-kHz crystal resonator ($\phi_{SUB} = \phi_W/8$) | — | 30.0 | — | | * Reference value |

| Item | Symbol | Applicable Pins | Test Condition | Values | | | Unit | Notes |
|-----------------------------------|-------------|-----------------|--|--------|------|------|---------------|-------|
| | | | | Min | Typ | Max | | |
| Subsleep mode current consumption | I_{SUBSP} | V_{CC} | $V_{CC} = 3.0\text{ V}$ 32-kHz crystal resonator ($\phi_{SUB} = \phi_W/2$) | — | 30.0 | 50.0 | μA | * |
| Standby mode current consumption | I_{STBY} | V_{CC} | 32-kHz crystal resonator not used | — | — | 5.0 | μA | * |
| RAM data retaining voltage | V_{RAM} | V_{CC} | | 2.0 | — | — | V | |

Note: * Pin states during current consumption measurement are given below (excluding current in the pull-up MOS transistors and output buffers).

| Mode | \overline{RES} Pin | Internal State | Other Pins | Oscillator Pins |
|----------------|----------------------|--|------------|---|
| Active mode 1 | V_{CC} | Operates | V_{CC} | Main clock: ceramic or crystal resonator |
| Active mode 2 | | Operates ($\phi_{OSC}/64$) | | Subclock: Pin X1 = V_{SS} |
| Sleep mode 1 | V_{CC} | Only timers operate | V_{CC} | |
| Sleep mode 2 | | Only timers operate ($\phi_{OSC}/64$) | | |
| Subactive mode | V_{CC} | Operates | V_{CC} | Main clock: ceramic or crystal resonator |
| Subsleep mode | V_{CC} | Only timers operate | V_{CC} | Subclock: crystal resonator |
| Standby mode | V_{CC} | CPU and timers both stop | V_{CC} | Main clock: ceramic or crystal resonator Subclock: Pin X1 = V_{SS} |

Table 21.2 DC Characteristics (2)

$V_{CC} = 3.0\text{ V to }5.5\text{ V}$, $V_{SS} = 0.0\text{ V}$, $T_a = -20^{\circ}\text{C to }+75^{\circ}\text{C}$, unless otherwise indicated.

| Item | Symbol | Applicable Pins | Test Condition | Values | | | Unit | Notes |
|---------------------------------------|--------------|-----------------|---|--------|-----|-----|---------------|-------|
| | | | | Min | Typ | Max | | |
| EEPROM current consump- tion | I_{EEW} | V_{CC} | $V_{CC} = 5.0\text{ V}$, $t_{SCL} = 2.5\text{ }\mu\text{s}$ (when writing) | — | — | 2.0 | mA | * |
| | I_{EER} | V_{CC} | $V_{CC} = 5.0\text{ V}$, $t_{SCL} = 2.5\text{ }\mu\text{s}$ (when reading) | — | — | 0.3 | mA | |
| | I_{EESTBY} | V_{CC} | $V_{CC} = 5.0\text{ V}$, $t_{SCL} = 2.5\text{ }\mu\text{s}$ (at standby) | — | — | 3.0 | μA | |

Note: * The current consumption of the EEPROM chip is shown.
For the current consumption of H8/3694N, add the above current values to the current consumption of H8/3694F.

Table 21.2 DC Characteristics (3)

$V_{CC} = 3.0$ to 5.5 V, $V_{SS} = 0.0$ V, $T_a = -20$ to $+75^\circ\text{C}$, unless otherwise indicated.

| Item | Symbol | Applicable Pins | Test Condition | Values | | | Unit |
|---|----------------------|---|---------------------------|--------|-----|------|------|
| | | | | Min | Typ | Max | |
| Allowable output low current (per pin) | I_{OL} | Output pins except port 8, SCL, and SDA | $V_{CC} = 4.0$ to 5.5 V | — | — | 2.0 | mA |
| | | Port 8 | | — | — | 20.0 | |
| | | Port 8 | | — | — | 10.0 | |
| | | SCL and SDA | | — | — | 6.0 | |
| | | Output pins except port 8, SCL, and SDA | | — | — | 0.5 | |
| Allowable output low current (total) | ΣI_{OL} | Output pins except port 8, SCL, and SDA | $V_{CC} = 4.0$ to 5.5 V | — | — | 40.0 | mA |
| | | Port 8, SCL, and SDA | | — | — | 80.0 | |
| | | Output pins except port 8, SCL, and SDA | | — | — | 20.0 | |
| | | Port 8, SCL, and SDA | | — | — | 40.0 | |
| Allowable output high current (per pin) | $ -I_{OH} $ | All output pins | $V_{CC} = 4.0$ to 5.5 V | — | — | 2.0 | mA |
| | | | | — | — | 0.2 | |
| Allowable output high current (total) | $ -\Sigma I_{OH} $ | All output pins | $V_{CC} = 4.0$ to 5.5 V | — | — | 30.0 | mA |
| | | | | — | — | 8.0 | |

21.2.3 AC Characteristics

Table 21.3 AC Characteristics

$V_{CC} = 3.0$ to 5.5 V, $V_{SS} = 0.0$ V, $T_a = -20$ to $+75^\circ\text{C}$, unless otherwise indicated.

| Item | Symbol | Applicable Pins | Test Condition | Values | | | Unit | Reference Figure |
|--|--------------|-----------------|---|----------|--------|------|---------------------------|------------------|
| | | | | Min | Typ | Max | | |
| System clock oscillation frequency | f_{OSC} | OSC1, OSC2 | $V_{CC} = 4.0$ to 5.5 V | 2.0 | — | 20.0 | MHz | * ¹ |
| | | | | 2.0 | — | 10.0 | | |
| System clock (ϕ) cycle time | t_{cyc} | | | 1 | — | 64 | t_{OSC} | * ² |
| | | | | — | — | 12.8 | | |
| Subclock oscillation frequency | f_W | X1, X2 | | — | 32.768 | — | kHz | |
| Watch clock (ϕ_W) cycle time | t_W | X1, X2 | | — | 30.5 | — | μs | |
| Subclock (ϕ_{SUB}) cycle time | t_{subcyc} | | | 2 | — | 8 | t_W | * ² |
| Instruction cycle time | | | | 2 | — | — | t_{cyc} t_{subcyc} | |
| Oscillation stabilization time (crystal resonator) | t_{rc} | OSC1, OSC2 | | — | — | 10.0 | ms | |
| Oscillation stabilization time (ceramic resonator) | t_{rc} | OSC1, OSC2 | | — | — | 5.0 | ms | |
| Oscillation stabilization time | t_{rcx} | X1, X2 | | — | — | 2.0 | s | |
| External clock high width | t_{CPH} | OSC1 | $V_{CC} = 4.0$ to 5.5 V | 20.0 | — | — | ns | Figure 21.1 |
| | | | | 40.0 | — | — | | |
| External clock low width | t_{CPL} | OSC1 | $V_{CC} = 4.0$ to 5.5 V | 20.0 | — | — | ns | |
| | | | | 40.0 | — | — | | |
| External clock rise time | t_{CPr} | OSC1 | $V_{CC} = 4.0$ to 5.5 V | — | — | 10.0 | ns | |
| | | | | — | — | 15.0 | | |
| External clock fall time | t_{CPl} | OSC1 | $V_{CC} = 4.0$ to 5.5 V | — | — | 10.0 | ns | |
| | | | | — | — | 15.0 | | |
| RES pin low width | t_{REL} | RES | At power-on and in modes other than those below | t_{rc} | — | — | ms | Figure 21.2 |
| | | | In active mode and sleep mode operation | 200 | — | — | | |

| Item | Symbol | Applicable Pins | Test Condition | Values | | | Unit | Reference Figure |
|----------------------|----------|---|----------------|--------|-----|-----|---------------------------|------------------|
| | | | | Min | Typ | Max | | |
| Input pin high width | t_{IH} | NMI, IRQ0 to IRQ3, WKP0 to WKP5, TMCIV, TMRIV, TRGV, ADTRG, FTCI, FTIOA to FTIOD | | 2 | — | — | t_{cyc} t_{subcyc} | Figure 21.3 |
| Input pin low width | t_{IL} | NMI, IRQ0 to IRQ3, WKP0 to WKP5, TMCIV, TMRIV, TRGV, ADTRG, FTCI, FTIOA to FTIOD | | 2 | — | — | t_{cyc} t_{subcyc} | |

- Notes: 1. When an external clock is input, the minimum system clock oscillation frequency is 1.0 MHz.
2. Determined by MA2, MA1, MA0, SA1, and SA0 of system control register 2 (SYSCR2).

Table 21.4 I²C Bus Interface Timing

$V_{CC} = 3.0$ to 5.5 V, $V_{SS} = 0.0$ V, $T_a = -20$ to $+75^{\circ}\text{C}$, unless otherwise indicated.

| Item | Symbol | Test Condition | Values | | | Unit | Reference Figure |
|---|------------|---------------------------|-------------------|-----|------------|------|------------------|
| | | | Min | Typ | Max | | |
| SCL input cycle time | t_{SCL} | | $12t_{cyc} + 600$ | — | — | ns | Figure 21.4 |
| SCL input high width | t_{SCLH} | | $3t_{cyc} + 300$ | — | — | ns | |
| SCL input low width | t_{SCLL} | | $5t_{cyc} + 300$ | — | — | ns | |
| SCL and SDA input fall time | t_{Sf} | | — | — | 300 | ns | |
| SCL and SDA input spike pulse removal time | t_{SP} | | — | — | $1t_{cyc}$ | ns | |
| SDA input bus-free time | t_{BUF} | | $5t_{cyc}$ | — | — | ns | |
| Start condition input hold time | t_{STAH} | | $3t_{cyc}$ | — | — | ns | |
| Retransmission start condition input setup time | t_{STAS} | | $3t_{cyc}$ | — | — | ns | |
| Setup time for stop condition input | t_{STOS} | | $3t_{cyc}$ | — | — | ns | |
| Data-input setup time | t_{SDAS} | | $1t_{cyc} + 20$ | — | — | ns | |
| Data-input hold time | t_{SDAH} | | 0 | — | — | ns | |
| Capacitive load of SCL and SDA | c_b | | 0 | — | 400 | pF | |
| SCL and SDA output fall time | t_{Sf} | $V_{CC} = 4.0$ to 5.5 V | — | — | 250 | ns | |
| | | | — | — | 300 | | |

Table 21.5 Serial Communication Interface (SCI) Timing

$V_{CC} = 3.0$ to 5.5 V, $V_{SS} = 0.0$ V, $T_a = -20$ to $+75^\circ\text{C}$, unless otherwise indicated.

| Item | Symbol | Applicable Pins | Test Condition | Values | | | Unit | Reference Figure |
|--|---------------------|-----------------|-----------------------------|--------|-----|-----|------------|------------------|
| | | | | Min | Typ | Max | | |
| Input clock cycle | Asynchronous | t_{Scyc} | SCK3 | 4 | — | — | t_{cyc} | Figure 21.5 |
| | Clocked synchronous | | | 6 | — | — | | |
| Input clock pulse width | t_{SCKW} | SCK3 | | 0.4 | — | 0.6 | t_{Scyc} | |
| Transmit data delay time (clocked synchronous) | t_{TXD} | TXD | $V_{CC} = 4.0$ V to 5.5 V | — | — | 1 | t_{cyc} | Figure 21.6 |
| | | | | — | — | 1 | | |
| Receive data setup time (clocked synchronous) | t_{RXS} | RXD | $V_{CC} = 4.0$ V to 5.5 V | 50.0 | — | — | ns | |
| | | | | 100.0 | — | — | | |
| Receive data hold time (clocked synchronous) | t_{RXH} | RXD | $V_{CC} = 4.0$ V to 5.5 V | 50.0 | — | — | ns | |
| | | | | 100.0 | — | — | | |

21.2.4 A/D Converter Characteristics

Table 21.6 A/D Converter Characteristics

$V_{CC} = 3.0$ to 5.5 V, $V_{SS} = 0.0$ V, $T_a = -20$ to $+75^\circ\text{C}$, unless otherwise indicated.

| Item | Symbol | Applicable Pins | Test Condition | Values | | | Unit | Reference Figure |
|-----------------------------------|--------------|-----------------|---|----------------|----------|-----------------|---------------|-----------------------|
| | | | | Min | Typ | Max | | |
| Analog power supply voltage | AV_{CC} | AV_{CC} | | 3.3 | V_{CC} | 5.5 | V | *1 |
| Analog input voltage | AV_{IN} | AN0 to AN7 | | $V_{SS} - 0.3$ | — | $AV_{CC} + 0.3$ | V | |
| Analog power supply current | AI_{OPE} | AV_{CC} | $AV_{CC} = 5.0$ V $f_{OSC} = 20$ MHz | — | — | 2.0 | mA | |
| | AI_{STOP1} | AV_{CC} | | — | 50 | — | μA | *2 Reference value |
| | AI_{STOP2} | AV_{CC} | | — | — | 5.0 | μA | *3 |
| Analog input capacitance | C_{AIN} | AN0 to AN7 | | — | — | 30.0 | pF | |
| Allowable signal source impedance | R_{AIN} | AN0 to AN7 | | — | — | 5.0 | k Ω | |
| Resolution (data length) | | | | 10 | 10 | 10 | bit | |
| Conversion time (single mode) | | | $AV_{CC} = 3.3$ to 5.5 V | 134 | — | — | t_{cyc} | |
| Nonlinearity error | | | | — | — | ± 7.5 | LSB | |
| Offset error | | | | — | — | ± 7.5 | LSB | |
| Full-scale error | | | | — | — | ± 7.5 | LSB | |
| Quantization error | | | | — | — | ± 0.5 | LSB | |
| Absolute accuracy | | | | — | — | ± 8.0 | LSB | |
| Conversion time (single mode) | | | $AV_{CC} = 4.0$ to 5.5 V | 70 | — | — | t_{cyc} | |
| Nonlinearity error | | | | — | — | ± 7.5 | LSB | |
| Offset error | | | | — | — | ± 7.5 | LSB | |
| Full-scale error | | | | — | — | ± 7.5 | LSB | |
| Quantization error | | | | — | — | ± 0.5 | LSB | |
| Absolute accuracy | | | | — | — | ± 8.0 | LSB | |

| Item | Symbol | Applicable Pins | Test Condition | Values | | | Unit | Reference Figure |
|-------------------------------|--------|-----------------|----------------------------|--------|-----|-----------|-----------|------------------|
| | | | | Min | Typ | Max | | |
| Conversion time (single mode) | | | $AV_{CC} = 4.0$ to 5.5 V | 134 | — | — | t_{cyc} | |
| Nonlinearity error | | | | — | — | ± 3.5 | LSB | |
| Offset error | | | | — | — | ± 3.5 | LSB | |
| Full-scale error | | | | — | — | ± 3.5 | LSB | |
| Quantization error | | | | — | — | ± 0.5 | LSB | |
| Absolute accuracy | | | | — | — | ± 4.0 | LSB | |

- Notes:
1. Set $AV_{CC} = V_{CC}$ when the A/D converter is not used.
 2. AI_{STOP1} is the current in active and sleep modes while the A/D converter is idle.
 3. AI_{STOP2} is the current at reset and in standby, subactive, and subsleep modes while the A/D converter is idle.

21.2.5 Watchdog Timer Characteristics

Table 21.7 Watchdog Timer Characteristics

$V_{CC} = 3.0$ to 5.5 V, $V_{SS} = 0.0$ V, $T_a = -20$ to $+75^\circ\text{C}$, unless otherwise indicated.

| Item | Symbol | Applicable Pins | Test Condition | Values | | | Unit | Reference Figure |
|----------------------------------|-----------|-----------------|----------------|--------|-----|-----|------|------------------|
| | | | | Min | Typ | Max | | |
| On-chip oscillator overflow time | t_{OVF} | | | 0.2 | 0.4 | — | s | * |

Note: * Shows the time to count from 0 to 255, at which point an internal reset is generated, when the internal oscillator is selected.

21.2.6 Flash Memory Characteristics

Table 21.8 Flash Memory Characteristics

$V_{CC} = 3.0$ to 5.5 V, $V_{SS} = 0.0$ V, $T_a = -20$ to $+75^\circ\text{C}$, unless otherwise indicated.

| Item | Symbol | Test Condition | Values | | | Unit | |
|--|--|----------------|------------------------|-------|------|---------------|---------------|
| | | | Min | Typ | Max | | |
| Programming time (per 128 bytes)* ¹ * ² * ⁴ | t_P | | — | 7 | 200 | ms | |
| Erase time (per block) * ¹ * ³ * ⁵ | t_E | | — | 100 | 1200 | ms | |
| Reprogramming count | N_{WEC} | | 1000 | 10000 | — | Times | |
| Programming | Wait time after SWE bit setting* ¹ | x | 1 | — | — | μs | |
| | Wait time after PSU bit setting* ¹ | y | 50 | — | — | μs | |
| | Wait time after P bit setting * ¹ * ⁴ | z1 | $1 \leq n \leq 6$ | 28 | 30 | 32 | μs |
| | | z2 | $7 \leq n \leq 1000$ | 198 | 200 | 202 | μs |
| | | z3 | Additional-programming | 8 | 10 | 12 | μs |
| | Wait time after P bit clear* ¹ | α | | 5 | — | — | μs |
| | Wait time after PSU bit clear* ¹ | β | | 5 | — | — | μs |
| | Wait time after PV bit setting* ¹ | γ | | 4 | — | — | μs |
| | Wait time after dummy write* ¹ | ϵ | | 2 | — | — | μs |
| | Wait time after PV bit clear* ¹ | η | | 2 | — | — | μs |
| | Wait time after SWE bit clear* ¹ | θ | | 100 | — | — | μs |
| | Maximum programming count * ¹ * ⁴ * ⁵ | N | | — | — | 1000 | Times |

| Item | | Symbol | Test Condition | Values | | | Unit |
|---------|---|--------|----------------|--------|-----|-----|-------|
| | | | | Min | Typ | Max | |
| Erasing | Wait time after SWE bit setting* ¹ | x | | 1 | — | — | μs |
| | Wait time after ESU bit setting* ¹ | y | | 100 | — | — | μs |
| | Wait time after E bit setting* ^{1,6} | z | | 10 | — | 100 | ms |
| | Wait time after E bit clear* ¹ | α | | 10 | — | — | μs |
| | Wait time after ESU bit clear* ¹ | β | | 10 | — | — | μs |
| | Wait time after EV bit setting* ¹ | γ | | 20 | — | — | μs |
| | Wait time after dummy write* ¹ | ε | | 2 | — | — | μs |
| | Wait time after EV bit clear* ¹ | η | | 4 | — | — | μs |
| | Wait time after SWE bit clear* ¹ | θ | | 100 | — | — | μs |
| | Maximum erase count * ^{1,6,7} | N | | — | — | 120 | Times |

- Notes:
1. Make the time settings in accordance with the program/erase algorithms.
 2. The programming time for 128 bytes. (Indicates the total time for which the P bit in flash memory control register 1 (FLMCR1) is set. The program-verify time is not included.)
 3. The time required to erase one block. (Indicates the time for which the E bit in flash memory control register 1 (FLMCR1) is set. The erase-verify time is not included.)
 4. Programming time maximum value (t_p (max.)) = wait time after P bit setting (z) × maximum programming count (N)
 5. Set the maximum programming count (N) according to the actual set values of z1, z2, and z3, so that it does not exceed the programming time maximum value (t_p (max.)). The wait time after P bit setting (z1, z2) should be changed as follows according to the value of the programming count (n).

Programming count (n)

$$1 \leq n \leq 6 \quad z1 = 30 \mu\text{s}$$

$$7 \leq n \leq 1000 \quad z2 = 200 \mu\text{s}$$

6. Erase time maximum value (t_e (max.)) = wait time after E bit setting (z) × maximum erase count (N)
7. Set the maximum erase count (N) according to the actual set value of (z), so that it does not exceed the erase time maximum value (t_e (max.)).

21.2.7 EEPROM Characteristics

Table 21.9 EEPROM Characteristics

$V_{CC} = 3.0\text{ V to }5.5\text{ V}$, $V_{SS} = 0.0\text{ V}$, $T_a = -20^\circ\text{C to }+75^\circ\text{C}$, unless otherwise specified.

| Item | Symbol | Test Condition | Values | | | Unit | Reference Figure |
|---|------------|----------------|--------|-----|-----|---------------|------------------|
| | | | Min | Typ | Max | | |
| SCL input cycle time | t_{SCL} | | 2500 | — | | ns | Figure 21.7 |
| SCL input high pulse width | t_{SCLH} | | 600 | — | — | μs | |
| SCL input low pulse width | t_{SCLL} | | 1200 | — | — | ns | |
| SCL, SDA input spike pulse removal time | t_{SP} | | — | — | 50 | ns | |
| SDA input bus-free time | t_{BUF} | | 1200 | — | — | ns | |
| Start condition input hold time | t_{STAH} | | 600 | — | — | ns | |
| Retransmit start condition input setup time | t_{STAS} | | 600 | — | — | ns | |
| Stop condition input setup time | t_{STOS} | | 600 | — | — | ns | |
| Data input setup time | t_{SDAS} | | 160 | — | — | ns | |
| Data input hold time | t_{SDAH} | | 0 | — | — | ns | |
| SCL, SDA input fall time | t_{Sf} | | — | — | 300 | ns | |
| SDA input rise time | t_{Sr} | | — | — | 300 | ns | |
| Data output hold time | t_{DH} | | 50 | — | — | ns | |
| SCL, SDA capacitive load | C_b | | 0 | — | 400 | pF | |
| Access time | t_{AA} | | 100 | — | 900 | ns | |
| Cycle time at writing* | t_{WC} | | — | — | 10 | ms | |
| Reset release time | t_{RES} | | — | — | 13 | ms | |

Note: * Cycle time at writing is a time from the stop condition to write completion (internal control).

21.2.8 Power-Supply-Voltage Detection Circuit Characteristics (Optional)

Table 21.10 Power-Supply-Voltage Detection Circuit Characteristics

$V_{SS} = 0.0 \text{ V}$, $T_a = -20 \text{ to } +75^\circ\text{C}$, unless otherwise indicated.

| Item | Symbol | Test Condition | Values | | | Unit |
|---|---------------|--|--------|-----|-----|---------------|
| | | | Min | Typ | Max | |
| Power-supply falling detection voltage | Vint (D) | LVDESEL = 0 | 3.3 | 3.7 | — | V |
| Power-supply rising detection voltage | Vint (U) | LVDESEL = 0 | — | 4.0 | 4.5 | V |
| Reset detection voltage 1* ¹ | Vreset1 | LVDESEL = 0 | — | 2.3 | 2.7 | V |
| Reset detection voltage 2* ² | Vreset2 | LVDESEL = 1 | 3.0 | 3.6 | 4.2 | V |
| Lower-limit voltage of LVDR operation* ³ | $V_{LVDRmin}$ | | 1.0 | — | — | V |
| LVD stabilization time | t_{LVDRON} | | 50 | — | — | μs |
| Current consumption in standby mode | I_{STBY} | LVDE = 1, Vcc = 5.0 V, When a 32- kHz crystal resonator is not used | — | — | 350 | μA |

- Notes:
1. This voltage should be used when the falling and rising voltage detection function is used.
 2. Select the low-voltage reset 2 when only the low-voltage detection reset is used.
 3. When the power-supply voltage (Vcc) falls below $V_{LVDRmin} = 1.0 \text{ V}$ and then rises, a reset may not occur. Therefore sufficient evaluation is required.

21.2.9 Power-On Reset Circuit Characteristics (Optional)

Table 21.11 Power-On Reset Circuit Characteristics

$V_{SS} = 0.0 \text{ V}$, $T_a = -20 \text{ to } +75^\circ\text{C}$, unless otherwise indicated.

| Item | Symbol | Test Condition | Values | | | Unit |
|---|------------------|----------------|--------|-----|-----|------------------|
| | | | Min | Typ | Max | |
| Pull-up resistance of $\overline{\text{RES}}$ pin | R_{RES} | | 100 | 150 | — | $\text{k}\Omega$ |
| Power-on reset start voltage* | V_{por} | | — | — | 100 | mV |

Note: * The power-supply voltage (V_{CC}) must fall below $V_{\text{por}} = 100 \text{ mV}$ and then rise after charge of the $\overline{\text{RES}}$ pin is removed completely. In order to remove charge of the $\overline{\text{RES}}$ pin, it is recommended that the diode be placed in the V_{CC} side. If the power-supply voltage (V_{CC}) rises from the point over 100 mV , a power-on reset may not occur.

21.3 Electrical Characteristics (Mask-ROM Version, EEPROM Stacked Mask-ROM Version)

21.3.1 Power Supply Voltage and Operating Ranges

Power Supply Voltage and Oscillation Frequency Range

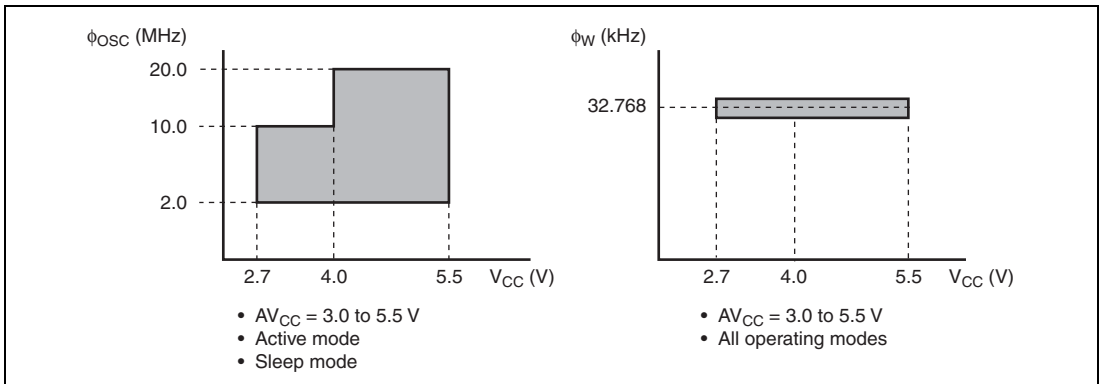

Power Supply Voltage and Operating Frequency Range

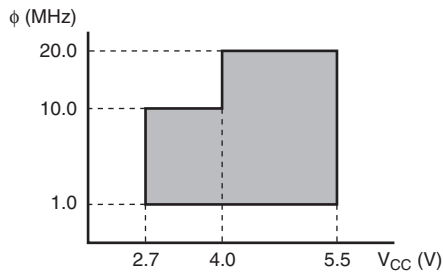

- $AV_{CC} = 3.0$ to 5.5 V
- Active mode
- Sleep mode
(When MA2 in SYSCR2 = 0)

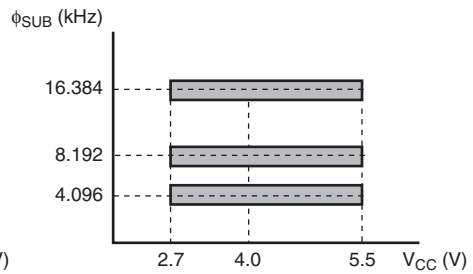

- $AV_{CC} = 3.0$ to 5.5 V
- Subactive mode
- Subsleep mode

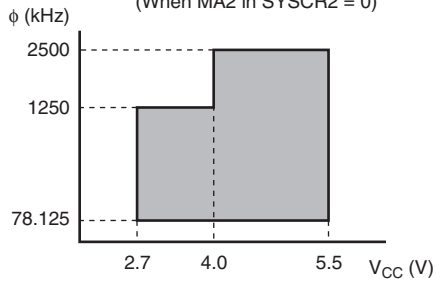

- $AV_{CC} = 3.0$ to 5.5 V
- Active mode
- Sleep mode
(When MA2 in SYSCR2 = 1)

Analog Power Supply Voltage and A/D Converter Accuracy Guarantee Range

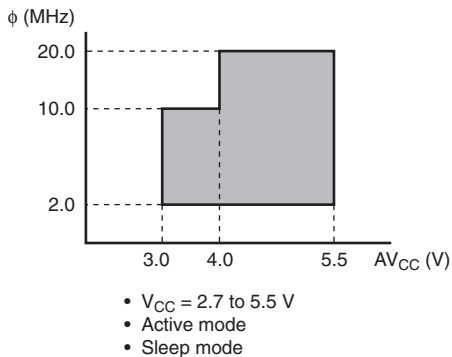

Range of Power Supply Voltage and Oscillation Frequency when Low-Voltage Detection Circuit is Used

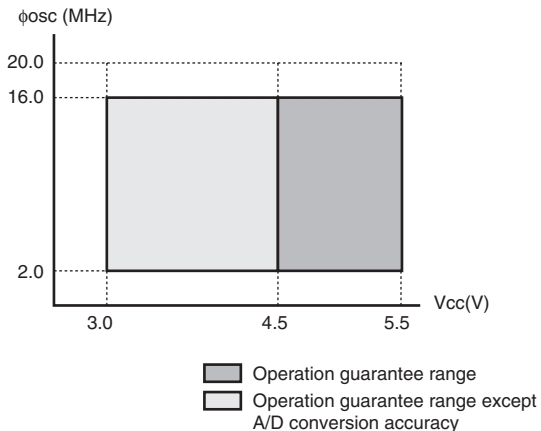

21.3.2 DC Characteristics

Table 21.12 DC Characteristics (1)

$V_{CC} = 2.7$ to 5.5 V, $V_{SS} = 0.0$ V, $T_a = -20$ to $+75^\circ\text{C}$, unless otherwise indicated.

| Item | Symbol | Applicable Pins | Test Condition | Values | | | Unit | Notes | |
|--------------------|----------|---|---------------------------|---------------------|----------------|---------------------|---------------------|-------|-----|
| | | | | Min | Typ | Max | | | |
| Input high voltage | V_{IH} | \overline{RES} , \overline{NMI} , $\overline{WKP0}$ to $\overline{WKP5}$, $\overline{IRQ0}$ to $\overline{IRQ3}$, \overline{ADTRG} , \overline{TMRIV} , TMCIV, FTCl, FTIOA to FTIOD, SCK3, TRGV | $V_{CC} = 4.0$ to 5.5 V | $V_{CC} \times 0.8$ | — | $V_{CC} + 0.3$ | V | | |
| | | | | $V_{CC} \times 0.9$ | — | $V_{CC} + 0.3$ | | | |
| | | RXD, SCL, SDA, P10 to P12, P14 to P17, P20 to P22, P50 to P57, P74 to P76, P80 to P87 | $V_{CC} = 4.0$ to 5.5 V | $V_{CC} \times 0.7$ | — | $V_{CC} + 0.3$ | V | | |
| | | | | $V_{CC} \times 0.8$ | — | $V_{CC} + 0.3$ | | | |
| | | PB0 to PB7 | $V_{CC} = 4.0$ to 5.5 V | $V_{CC} \times 0.7$ | — | $AV_{CC} + 0.3$ | V | | |
| | | | | $V_{CC} \times 0.8$ | — | $AV_{CC} + 0.3$ | | | |
| Input low voltage | V_{IL} | \overline{RES} , \overline{NMI} , $\overline{WKP0}$ to $\overline{WKP5}$, $\overline{IRQ0}$ to $\overline{IRQ3}$, \overline{ADTRG} , \overline{TMRIV} , TMCIV, FTCl, FTIOA to FTIOD, SCK3, TRGV | $V_{CC} = 4.0$ to 5.5 V | $V_{CC} - 0.5$ | — | $V_{CC} + 0.3$ | V | | |
| | | | | | $V_{CC} - 0.3$ | — | $V_{CC} + 0.3$ | | |
| | | | | | $V_{CC} - 0.3$ | — | $V_{CC} \times 0.2$ | V | |
| Input low voltage | V_{IL} | RXD, SCL, SDA, P10 to P12, P14 to P17, P20 to P22, P50 to P57, P74 to P76, P80 to P87, PB0 to PB7 | $V_{CC} = 4.0$ to 5.5 V | -0.3 | — | $V_{CC} \times 0.3$ | V | | |
| | | | | | -0.3 | — | $V_{CC} \times 0.2$ | | |
| | | | | | -0.3 | — | 0.5 | V | |
| | | | | | -0.3 | — | 0.3 | | |
| | | | | | | | -0.3 | — | 0.3 |

| Item | Symbol | Applicable Pins | Test Condition | Values | | | Unit | Notes |
|--|----------|---|--|---|---|-----|---------------|-------|
| | | | | Min | Typ | Max | | |
| Output high voltage | V_{OH} | P10 to P12, P14 to P17, P20 to P22, P50 to P55, P74 to P76, P80 to P87 | $V_{CC} = 4.0 \text{ to } 5.5 \text{ V}$ $-I_{OH} = 1.5 \text{ mA}$ | $V_{CC} - 1.0$ | — | — | V | |
| | | | $-I_{OH} = 0.1 \text{ mA}$ | $V_{CC} - 0.5$ | — | — | | |
| | | P56, P57 | $V_{CC} = 4.0 \text{ to } 5.5 \text{ V}$ $-I_{OH} = 0.1 \text{ mA}$ | $V_{CC} - 2.5$ | — | — | V | |
| | | | $V_{CC} = 2.7 \text{ to } 4.0 \text{ V}$ $-I_{OH} = 0.1 \text{ mA}$ | $V_{CC} - 2.0$ | — | — | | |
| Output low voltage | V_{OL} | P10 to P12, P14 to P17, P20 to P22, P50 to P57, P74 to P76 | $V_{CC} = 4.0 \text{ to } 5.5 \text{ V}$ $I_{OL} = 1.6 \text{ mA}$ | — | — | 0.6 | V | |
| | | | $I_{OL} = 0.4 \text{ mA}$ | — | — | 0.4 | | |
| | | P80 to P87 | $V_{CC} = 4.0 \text{ to } 5.5 \text{ V}$ $I_{OL} = 20.0 \text{ mA}$ | — | — | 1.5 | V | |
| | | | $V_{CC} = 4.0 \text{ to } 5.5 \text{ V}$ $I_{OL} = 10.0 \text{ mA}$ | — | — | 1.0 | | |
| | | | $V_{CC} = 4.0 \text{ to } 5.5 \text{ V}$ $I_{OL} = 1.6 \text{ mA}$ | — | — | 0.4 | | |
| | | | $I_{OL} = 0.4 \text{ mA}$ | — | — | 0.4 | | |
| | | SCL, SDA | $V_{CC} = 4.0 \text{ to } 5.5 \text{ V}$ $I_{OL} = 6.0 \text{ mA}$ | — | — | 0.6 | V | |
| | | | $I_{OL} = 3.0 \text{ mA}$ | — | — | 0.4 | | |
| | | | | | | | | |
| | | Input/output leakage current | $ I_{IL} $ | OSC1, \overline{NMI} , WKP0 to WKP5, $\overline{IRQ0}$ to $\overline{IRQ3}$, \overline{ADTRG} , TRGV, TMRIV, TMCIV, FTCI, FTIOA to FTIOD, RXD, SCK3, SCL, SDA | $V_{IN} = 0.5 \text{ V to } (V_{CC} - 0.5 \text{ V})$ | — | — | 1.0 |
| $V_{IN} = 0.5 \text{ V to } (V_{CC} - 0.5 \text{ V})$ | — | | | | — | 1.0 | μA | |
| $V_{IN} = 0.5 \text{ V to } (AV_{CC} - 0.5 \text{ V})$ | — | | | | — | 1.0 | μA | |

| Item | Symbol | Applicable Pins | Test Condition | Values | | | Unit | Notes |
|------------------------------------|--------------|---|--|--------|------|-------|-----------------|------------|
| | | | | Min | Typ | Max | | |
| Pull-up MOS current | $-I_p$ | P10 to P12, P14 to P17, P50 to P55 | $V_{CC} = 5.0\text{ V}$, $V_{IN} = 0.0\text{ V}$ | 50.0 | — | 300.0 | μA | |
| | | | $V_{CC} = 3.0\text{ V}$, $V_{IN} = 0.0\text{ V}$ | — | 60.0 | — | Reference value | |
| Input capacitance | C_{in} | All input pins except power supply pins | $f = 1\text{ MHz}$, $V_{IN} = 0.0\text{ V}$, $T_a = 25^\circ\text{C}$ | — | — | 15.0 | pF | |
| | | SDA, SCL | | — | — | 25.0 | pF | HD6483694G |
| Active mode current consumption | I_{OPE1} | V_{CC} | Active mode 1 $V_{CC} = 5.0\text{ V}$, $f_{OSC} = 20\text{ MHz}$ | — | 20.0 | 30.0 | mA | * |
| | | | Active mode 1 $V_{CC} = 3.0\text{ V}$, $f_{OSC} = 10\text{ MHz}$ | — | 8.0 | — | Reference value | |
| | I_{OPE2} | V_{CC} | Active mode 2 $V_{CC} = 5.0\text{ V}$, $f_{OSC} = 20\text{ MHz}$ | — | 2.0 | 3.0 | mA | * |
| | | | Active mode 2 $V_{CC} = 3.0\text{ V}$, $f_{OSC} = 10\text{ MHz}$ | — | 1.2 | — | Reference value | |
| Sleep mode current consumption | I_{SLEEP1} | V_{CC} | Sleep mode 1 $V_{CC} = 5.0\text{ V}$, $f_{OSC} = 20\text{ MHz}$ | — | 10.0 | 17.5 | mA | * |
| | | | Sleep mode 1 $V_{CC} = 3.0\text{ V}$, $f_{OSC} = 10\text{ MHz}$ | — | 5.5 | — | Reference value | |
| | I_{SLEEP2} | V_{CC} | Sleep mode 2 $V_{CC} = 5.0\text{ V}$, $f_{OSC} = 20\text{ MHz}$ | — | 1.6 | 2.4 | mA | * |
| | | | Sleep mode 2 $V_{CC} = 3.0\text{ V}$, $f_{OSC} = 10\text{ MHz}$ | — | 0.8 | — | Reference value | |
| Subactive mode current consumption | I_{SUB} | V_{CC} | $V_{CC} = 3.0\text{ V}$ 32-kHz crystal resonator ($\phi_{SUB} = \phi_W/2$) | — | 40.0 | 70.0 | μA | * |
| | | | $V_{CC} = 3.0\text{ V}$ 32-kHz crystal resonator ($\phi_{SUB} = \phi_W/8$) | — | 30.0 | — | Reference value | |

| Item | Symbol | Applicable Pins | Test Condition | Values | | | Unit | Notes |
|-----------------------------------|--------------------|-----------------|--|--------|------|------|---------------|-------|
| | | | | Min | Typ | Max | | |
| Subsleep mode current consumption | I_{SUBSP} | V_{CC} | $V_{\text{CC}} = 3.0 \text{ V}$ 32-kHz crystal resonator ($\phi_{\text{SUB}} = \phi_{\text{W}}/2$) | — | 30.0 | 50.0 | μA | * |
| Standby mode current consumption | I_{STBY} | V_{CC} | 32-kHz crystal resonator not used | — | — | 5.0 | μA | * |
| RAM data retaining voltage | V_{RAM} | V_{CC} | | 2.0 | — | — | V | |

Note: * Pin states during current consumption measurement are given below (excluding current in the pull-up MOS transistors and output buffers).

| Mode | $\overline{\text{RES}}$ Pin | Internal State | Other Pins | Oscillator Pins |
|----------------|-----------------------------|---|-----------------|--|
| Active mode 1 | V_{CC} | Operates | V_{CC} | Main clock: ceramic or crystal resonator |
| Active mode 2 | | Operates ($\phi_{\text{OSC}}/64$) | | Subclock: Pin X1 = V_{SS} |
| Sleep mode 1 | V_{CC} | Only timers operate | V_{CC} | |
| Sleep mode 2 | | Only timers operate ($\phi_{\text{OSC}}/64$) | | |
| Subactive mode | V_{CC} | Operates | V_{CC} | Main clock: ceramic or crystal resonator |
| Subsleep mode | V_{CC} | Only timers operate | V_{CC} | Subclock: crystal resonator |
| Standby mode | V_{CC} | CPU and timers both stop | V_{CC} | Main clock: ceramic or crystal resonator Subclock: Pin X1 = V_{SS} |

Table 21.12 DC Characteristics (2)

$V_{CC} = 2.7\text{ V to }5.5\text{ V}$, $V_{SS} = 0.0\text{ V}$, $T_a = -20^\circ\text{C to }+75^\circ\text{C}$, unless otherwise indicated.

| Item | Symbol | Applicable Pins | Test Condition | Values | | | Unit | Notes |
|---------------------------------------|--------------|-----------------|--|--------|-----|-----|---------------|-------|
| | | | | Min | Typ | Max | | |
| EEPROM current consump- tion | I_{EEW} | V_{CC} | $V_{CC} = 5.0\text{ V}$, $t_{SCL} = 2.5\text{ }\mu\text{s}$ (when writing) | — | — | 2.0 | mA | * |
| | I_{EER} | V_{CC} | $V_{CC} = 5.0\text{ V}$, $t_{SCL} = 2.5\text{ }\mu\text{s}$ (when reading) | — | — | 0.3 | mA | |
| | I_{EESTBY} | V_{CC} | $V_{CC} = 5.0\text{ V}$, $t_{SCL} = 2.5\text{ }\mu\text{s}$ (at standby) | — | — | 3.0 | μA | |

Note: * The current consumption of the EEPROM chip is shown.
For the current consumption of H8/3694N, add the above current values to the current consumption of H8/3694.

Table 21.12 DC Characteristics (3)

$V_{CC} = 2.7$ to 5.5 V, $V_{SS} = 0.0$ V, $T_a = -20$ to $+75^\circ\text{C}$, unless otherwise indicated.

| Item | Symbol | Applicable Pins | Test Condition | Values | | | Unit |
|---|----------------------|---|---------------------------|--------|-----|------|------|
| | | | | Min | Typ | Max | |
| Allowable output low current (per pin) | I_{OL} | Output pins except port 8, SCL, and SDA | $V_{CC} = 4.0$ to 5.5 V | — | — | 2.0 | mA |
| | | Port 8 | | — | — | 20.0 | |
| | | Port 8 | | — | — | 10.0 | |
| | | SCL, and SDA | | — | — | 6.0 | |
| | | Output pins except port 8, SCL, and SDA | | — | — | 0.5 | |
| Allowable output low current (total) | ΣI_{OL} | Output pins except port 8, SCL, and SDA | $V_{CC} = 4.0$ to 5.5 V | — | — | 40.0 | mA |
| | | Port 8, SCL, and SDA | | — | — | 80.0 | |
| | | Output pins except port 8, SCL, and SDA | | — | — | 20.0 | |
| | | Port 8, SCL, and SDA | | — | — | 40.0 | |
| Allowable output high current (per pin) | $ -I_{OH} $ | All output pins | $V_{CC} = 4.0$ to 5.5 V | — | — | 2.0 | mA |
| | | | | — | — | 0.2 | |
| Allowable output high current (total) | $ -\Sigma I_{OH} $ | All output pins | $V_{CC} = 4.0$ to 5.5 V | — | — | 30.0 | mA |
| | | | | — | — | 8.0 | |

21.3.3 AC Characteristics

Table 21.13 AC Characteristics
 $V_{CC} = 2.7$ to 5.5 V, $V_{SS} = 0.0$ V, $T_a = -20$ to $+75^\circ\text{C}$, unless otherwise indicated.

| Item | Symbol | Applicable Pins | Test Condition | Values | | | Unit | Reference Figure |
|--|--------------|-----------------|---|---|--------|------|---------------------------|------------------|
| | | | | Min | Typ | Max | | |
| System clock oscillation frequency | f_{OSC} | OSC1, OSC2 | $V_{CC} = 4.0$ to 5.5 V | 2.0 | — | 20.0 | MHz | * ¹ |
| | | | | 2.0 | — | 10.0 | | |
| System clock (ϕ) cycle time | t_{cyc} | | | 1 | — | 64 | t_{OSC} | * ² |
| | | | | — | — | 12.8 | | |
| Subclock oscillation frequency | f_W | X1, X2 | | — | 32.768 | — | kHz | |
| Watch clock (ϕ_W) cycle time | t_W | X1, X2 | | — | 30.5 | — | μs | |
| Subclock (ϕ_{SUB}) cycle time | t_{subcyc} | | | 2 | — | 8 | t_W | * ² |
| Instruction cycle time | | | | 2 | — | — | t_{cyc} t_{subcyc} | |
| Oscillation stabilization time (crystal resonator) | t_{rc} | OSC1, OSC2 | | — | — | 10.0 | ms | |
| Oscillation stabilization time (ceramic resonator) | t_{rc} | OSC1, OSC2 | | — | — | 5.0 | ms | |
| Oscillation stabilization time | t_{rcx} | X1, X2 | | — | — | 2.0 | s | |
| External clock high width | t_{CPH} | OSC1 | $V_{CC} = 4.0$ to 5.5 V | 20.0 | — | — | ns | Figure 21.1 |
| | | | | 40.0 | — | — | | |
| External clock low width | t_{CPL} | OSC1 | $V_{CC} = 4.0$ to 5.5 V | 20.0 | — | — | ns | |
| | | | | 40.0 | — | — | | |
| External clock rise time | t_{CPr} | OSC1 | $V_{CC} = 4.0$ to 5.5 V | — | — | 10.0 | ns | |
| | | | | — | — | 15.0 | | |
| External clock fall time | t_{CPf} | OSC1 | $V_{CC} = 4.0$ to 5.5 V | — | — | 10.0 | ns | |
| | | | | — | — | 15.0 | | |
| RES pin low width | t_{REL} | RES | At power-on and in modes other than those below | — | — | — | ms | Figure 21.2 |
| | | | | In active mode and sleep mode operation | 200 | — | | |

| Item | Symbol | Applicable Pins | Test Condition | Values | | | Unit | Reference Figure |
|----------------------|----------|--|----------------|--------|-----|-----|---------------------------|------------------|
| | | | | Min | Typ | Max | | |
| Input pin high width | t_{IH} | NMI, $\overline{IRQ0}$ to $\overline{IRQ3}$, WKP0 to WKP5, TMCIV, TMRIV, TRGV, ADTRG, FTCI, FTIOA to FTIOD | | 2 | — | — | t_{cyc} t_{subcyc} | Figure 21.3 |
| Input pin low width | t_{IL} | NMI, $\overline{IRQ0}$ to $\overline{IRQ3}$, WKP0 to WKP5, TMCIV, TMRIV, TRGV, ADTRG, FTCI, FTIOA to FTIOD | | 2 | — | — | t_{cyc} t_{subcyc} | |

- Notes: 1 When an external clock is input, the minimum system clock oscillation frequency is 1.0 MHz.
2. Determined by MA2, MA1, MA0, SA1, and SA0 of system control register 2 (SYSCR2).

Table 21.14 I²C Bus Interface Timing

$V_{CC} = 2.7\text{ V to }5.5\text{ V}$, $V_{SS} = 0.0\text{ V}$, $T_a = -20\text{ to }+75^\circ\text{C}$, unless otherwise specified.

| Item | Symbol | Test Condition | Values | | | Unit | Reference Figure |
|---|------------|---------------------------------------|-------------------|-----|------------|------|------------------|
| | | | Min | Typ | Max | | |
| SCL input cycle time | t_{SCL} | | $12t_{cyc} + 600$ | — | — | ns | Figure 21.4 |
| SCL input high width | t_{SCLH} | | $3t_{cyc} + 300$ | — | — | ns | |
| SCL input low width | t_{SCLL} | | $5t_{cyc} + 300$ | — | — | ns | |
| SCL and SDA input fall time | t_{Sf} | | — | — | 300 | ns | |
| SCL and SDA input spike pulse removal time | t_{SP} | | — | — | $1t_{cyc}$ | ns | |
| SDA input bus-free time | t_{BUF} | | $5t_{cyc}$ | — | — | ns | |
| Start condition input hold time | t_{STAH} | | $3t_{cyc}$ | — | — | ns | |
| Retransmission start condition input setup time | t_{STAS} | | $3t_{cyc}$ | — | — | ns | |
| Setup time for stop condition input | t_{STOS} | | $3t_{cyc}$ | — | — | ns | |
| Data-input setup time | t_{SDAS} | | $1t_{cyc} + 20$ | — | — | ns | |
| Data-input hold time | t_{SDAH} | | 0 | — | — | ns | |
| Capacitive load of SCL and SDA | c_o | | 0 | — | 400 | pF | |
| SCL and SDA output fall time | t_{Sf} | $V_{CC} = 4.0\text{ to }5.5\text{ V}$ | — | — | 250 | ns | |
| | | | — | — | 300 | | |

Table 21.15 Serial Communication Interface (SCI) Timing

$V_{CC} = 2.7\text{ V to }5.5\text{ V}$, $V_{SS} = 0.0\text{ V}$, $T_a = -20\text{ to }+75^\circ\text{C}$, unless otherwise specified.

| Item | Symbol | Applicable Pins | Test Condition | Values | | | Unit | Reference Figure |
|--|---------------------|-------------------|---------------------------------------|--------|-----|-----|--------------------------|------------------|
| | | | | Min | Typ | Max | | |
| Input clock cycle | Asynchronous | $t_{S\text{cyc}}$ | SCK3 | 4 | — | — | t_{cyc} | Figure 21.5 |
| | Clocked synchronous | | | 6 | — | — | | |
| Input clock pulse width | t_{SCKW} | SCK3 | | 0.4 | — | 0.6 | $t_{\text{S\text{cyc}}}$ | |
| Transmit data delay time (clocked synchronous) | t_{TXD} | TXD | $V_{CC} = 4.0\text{ to }5.5\text{ V}$ | — | — | 1 | t_{cyc} | Figure 21.6 |
| | | | | — | — | 1 | | |
| Receive data setup time (clocked synchronous) | t_{RXS} | RXD | $V_{CC} = 4.0\text{ to }5.5\text{ V}$ | 50.0 | — | — | ns | |
| | | | | 100.0 | — | — | | |
| Receive data hold time (clocked synchronous) | t_{RXH} | RXD | $V_{CC} = 4.0\text{ to }5.5\text{ V}$ | 50.0 | — | — | ns | |
| | | | | 100.0 | — | — | | |

21.3.4 A/D Converter Characteristics

Table 21.16 A/D Converter Characteristics

$V_{CC} = 2.7$ to 5.5 V, $V_{SS} = 0.0$ V, $T_a = -20$ to $+75^\circ\text{C}$, unless otherwise indicated.

| Item | Symbol | Applicable Pins | Test Condition | Values | | | Unit | Reference Figure |
|-----------------------------------|--------------|-----------------|---|----------------|----------|-----------------|---------------|-----------------------|
| | | | | Min | Typ | Max | | |
| Analog power supply voltage | AV_{CC} | AV_{CC} | | 3.0 | V_{CC} | 5.5 | V | *1 |
| Analog input voltage | AV_{IN} | AN0 to AN7 | | $V_{SS} - 0.3$ | — | $AV_{CC} + 0.3$ | V | |
| Analog power supply current | AI_{OPE} | AV_{CC} | $AV_{CC} = 5.0$ V $f_{OSC} = 20$ MHz | — | — | 2.0 | mA | |
| | AI_{STOP1} | AV_{CC} | | — | 50 | — | μA | *2 Reference value |
| | AI_{STOP2} | AV_{CC} | | — | — | 5.0 | μA | *3 |
| Analog input capacitance | C_{AIN} | AN0 to AN7 | | — | — | 30.0 | pF | |
| Allowable signal source impedance | R_{AIN} | AN0 to AN7 | | — | — | 5.0 | k Ω | |
| Resolution (data length) | | | | 10 | 10 | 10 | bit | |
| Conversion time (single mode) | | | $AV_{CC} = 3.0$ to 5.5 V | 134 | — | — | t_{cyc} | |
| Nonlinearity error | | | | — | — | ± 7.5 | LSB | |
| Offset error | | | | — | — | ± 7.5 | LSB | |
| Full-scale error | | | | — | — | ± 7.5 | LSB | |
| Quantization error | | | | — | — | ± 0.5 | LSB | |
| Absolute accuracy | | | | — | — | ± 8.0 | LSB | |
| Conversion time (single mode) | | | $AV_{CC} = 4.0$ to 5.5 V | 70 | — | — | t_{cyc} | |
| Nonlinearity error | | | | — | — | ± 7.5 | LSB | |
| Offset error | | | | — | — | ± 7.5 | LSB | |
| Full-scale error | | | | — | — | ± 7.5 | LSB | |
| Quantization error | | | | — | — | ± 0.5 | LSB | |
| Absolute accuracy | | | | — | — | ± 8.0 | LSB | |

| Item | Symbol | Applicable Pins | Test Condition | Values | | | Unit | Reference Figure |
|-------------------------------|--------|-----------------|----------------------------|--------|-----|-----------|-----------|------------------|
| | | | | Min | Typ | Max | | |
| Conversion time (single mode) | | | $AV_{CC} = 4.0$ to 5.5 V | 134 | — | — | t_{cyc} | |
| Nonlinearity error | | | | — | — | ± 3.5 | LSB | |
| Offset error | | | | — | — | ± 3.5 | LSB | |
| Full-scale error | | | | — | — | ± 3.5 | LSB | |
| Quantization error | | | | — | — | ± 0.5 | LSB | |
| Absolute accuracy | | | | — | — | ± 4.0 | LSB | |

- Notes: 1. Set $AV_{CC} = V_{CC}$ when the A/D converter is not used.
 2. AI_{STOP1} is the current in active and sleep modes while the A/D converter is idle.
 3. AI_{STOP2} is the current at reset and in standby, subactive, and subsleep modes while the A/D converter is idle.

21.3.5 Watchdog Timer Characteristics

Table 21.17 Watchdog Timer Characteristics

$V_{CC} = 2.7$ to 5.5 V, $V_{SS} = 0.0$ V, $T_a = -20$ to $+75^\circ\text{C}$, unless otherwise indicated.

| Item | Symbol | Applicable Pins | Test Condition | Values | | | Unit | Reference Figure |
|----------------------------------|-----------|-----------------|----------------|--------|-----|-----|------|------------------|
| | | | | Min | Typ | Max | | |
| On-chip oscillator overflow time | t_{OVF} | | | 0.2 | 0.4 | — | s | * |

Note: * Shows the time to count from 0 to 255, at which point an internal reset is generated, when the internal oscillator is selected.

21.3.6 EEPROM Characteristics

Table 21.18 EEPROM Characteristics

$V_{CC} = 2.7\text{ V to }5.5\text{ V}$, $V_{SS} = 0.0\text{ V}$, $T_a = -20^\circ\text{C to }+75^\circ\text{C}$, unless otherwise indicated.

| Item | Symbol | Test Condition | Values | | | Unit | Reference Figure |
|---|------------|----------------|--------|-----|-----|---------------|------------------|
| | | | Min | Typ | Max | | |
| SCL input cycle time | t_{SCL} | | 2500 | — | | ns | Figure 21.7 |
| SCL input high pulse width | t_{SCLH} | | 600 | — | — | μs | |
| SCL input low pulse width | t_{SCLL} | | 1200 | — | — | ns | |
| SCL, SDA input spike pulse removal time | t_{SP} | | — | — | 50 | ns | |
| SDA input bus-free time | t_{BUF} | | 1200 | — | — | ns | |
| Start condition input hold time | t_{STAH} | | 600 | — | — | ns | |
| Retransmit start condition input setup time | t_{STAS} | | 600 | — | — | ns | |
| Stop condition input setup time | t_{STOS} | | 600 | — | — | ns | |
| Data input setup time | t_{SDAS} | | 160 | — | — | ns | |
| Data input hold time | t_{SDAH} | | 0 | — | — | ns | |
| SCL, SDA input fall time | t_{Sf} | | — | — | 300 | ns | |
| SDA input rise time | t_{Sr} | | — | — | 300 | ns | |
| Data output hold time | t_{DH} | | 50 | — | — | ns | |
| SCL, SDA capacitive load | C_b | | 0 | — | 400 | pF | |
| Access time | t_{AA} | | 100 | — | 900 | ns | |
| Cycle time at writing* | t_{WC} | | — | — | 10 | ms | |
| Reset release time | t_{RES} | | — | — | 13 | ms | |

Note: * Cycle time at writing is a time from the stop condition to write completion (internal control).

21.3.7 Power-Supply-Voltage Detection Circuit Characteristics (Optional)

Table 21.19 Power-Supply-Voltage Detection Circuit Characteristics

$V_{SS} = 0.0 \text{ V}$, $T_a = -20 \text{ to } +75^\circ\text{C}$, unless otherwise indicated.

| Item | Symbol | Test Condition | Values | | | Unit |
|---|---------------|--|--------|-----|-----|---------------|
| | | | Min | Typ | Max | |
| Power-supply falling detection voltage | Vint (D) | LVDSSEL = 0 | 3.3 | 3.7 | — | V |
| Power-supply rising detection voltage | Vint (U) | LVDSSEL = 0 | — | 4.0 | 4.5 | V |
| Reset detection voltage 1* ¹ | Vreset1 | LVDSSEL = 0 | — | 2.3 | 2.7 | V |
| Reset detection voltage 2* ² | Vreset2 | LVDSSEL = 1 | 3.0 | 3.6 | 4.2 | V |
| Lower-limit voltage of LVDR operation* ³ | $V_{LVDRmin}$ | | 1.0 | — | — | V |
| LVD stabilization time | t_{LVDRON} | | 50 | — | — | μs |
| Current consumption in standby mode | I_{STBY} | LVDE = 1, Vcc = 5.0 V, When a 32- kHz crystal resonator is not used | — | — | 350 | μA |

- Notes:
1. This voltage should be used when the falling and rising voltage detection function is used.
 2. Select the low-voltage reset 2 when only the low-voltage detection reset is used.
 3. When the power-supply voltage (Vcc) falls below $V_{LVDRmin} = 1.0 \text{ V}$ and then rises, a reset may not occur. Therefore sufficient evaluation is required.

21.3.8 Power-On Reset Circuit Characteristics (Optional)

Table 21.20 Power-On Reset Circuit Characteristics

$V_{SS} = 0.0 \text{ V}$, $T_a = -20 \text{ to } +75^\circ\text{C}$, unless otherwise indicated.

| Item | Symbol | Test Condition | Values | | | Unit |
|---|------------------|----------------|--------|-----|-----|------------------|
| | | | Min | Typ | Max | |
| Pull-up resistance of $\overline{\text{RES}}$ pin | R_{RES} | | 100 | 150 | — | $\text{k}\Omega$ |
| Power-on reset start voltage* | V_{por} | | — | — | 100 | mV |

Note: * The power-supply voltage (V_{CC}) must fall below $V_{\text{por}} = 100 \text{ mV}$ and then rise after charge of the $\overline{\text{RES}}$ pin is removed completely. In order to remove charge of the $\overline{\text{RES}}$ pin, it is recommended that the diode be placed in the V_{CC} side. If the power-supply voltage (V_{CC}) rises from the point over 100 mV , a power-on reset may not occur.

21.4 Operation Timing

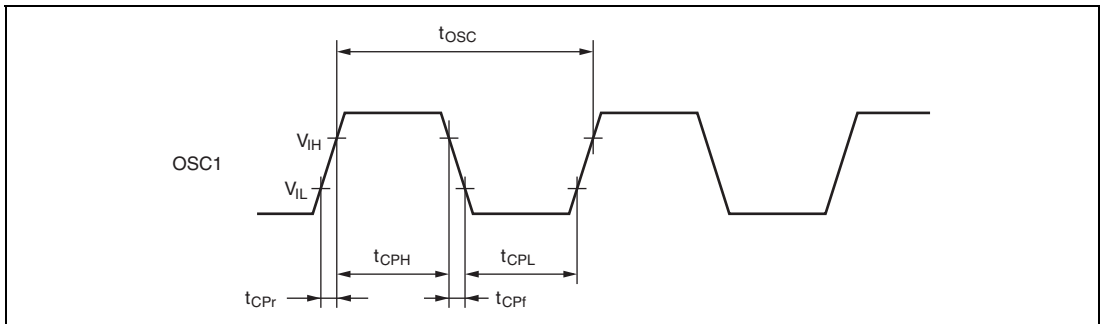

Figure 21.1 System Clock Input Timing

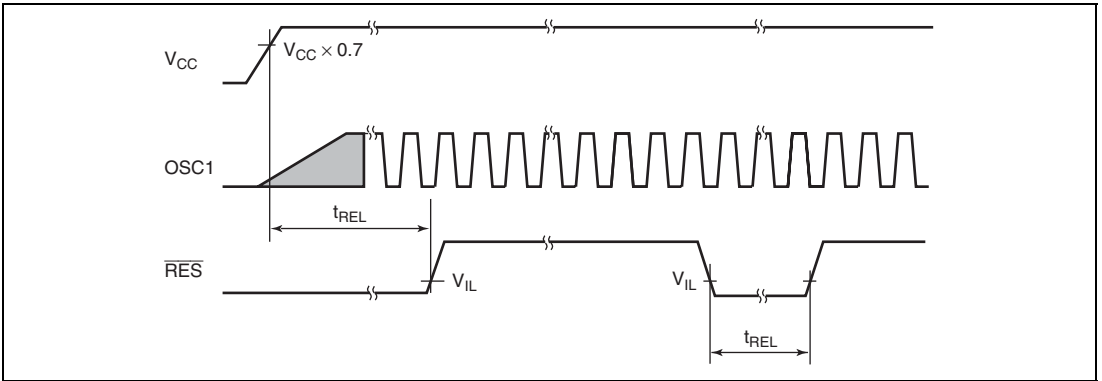

Figure 21.2 $\overline{\text{RES}}$ Low Width Timing

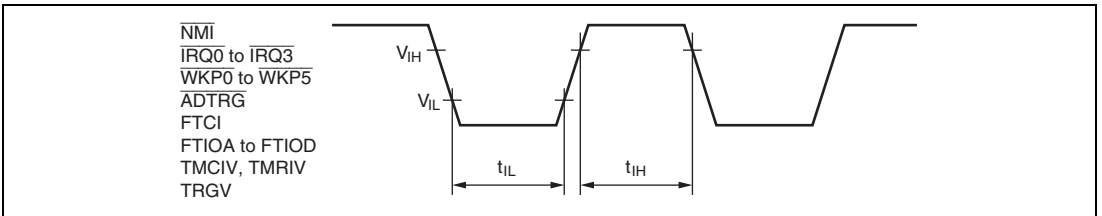

Figure 21.3 Input Timing

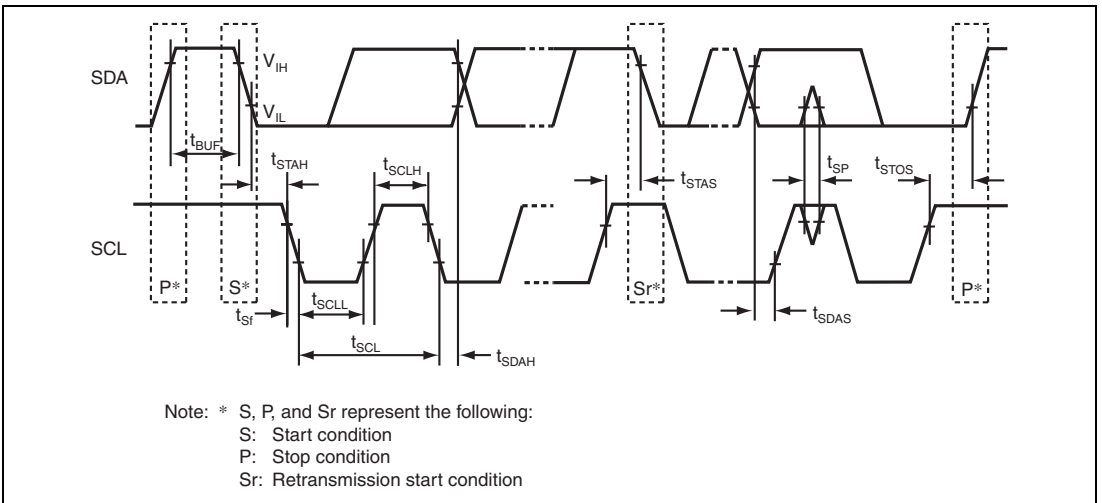

Figure 21.4 I²C Bus Interface Input/Output Timing

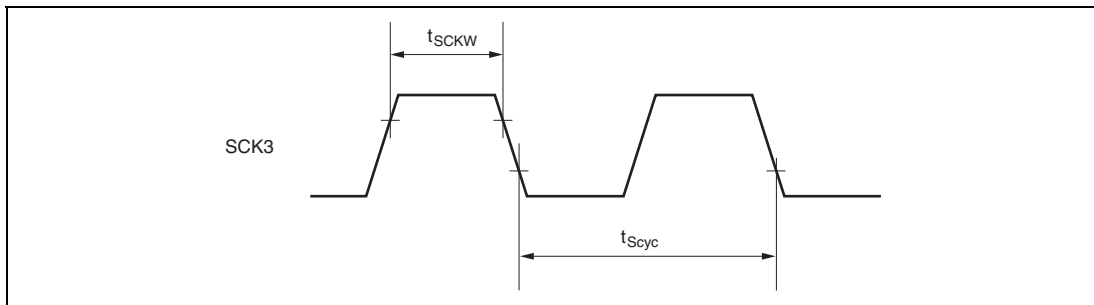

Figure 21.5 SCK3 Input Clock Timing

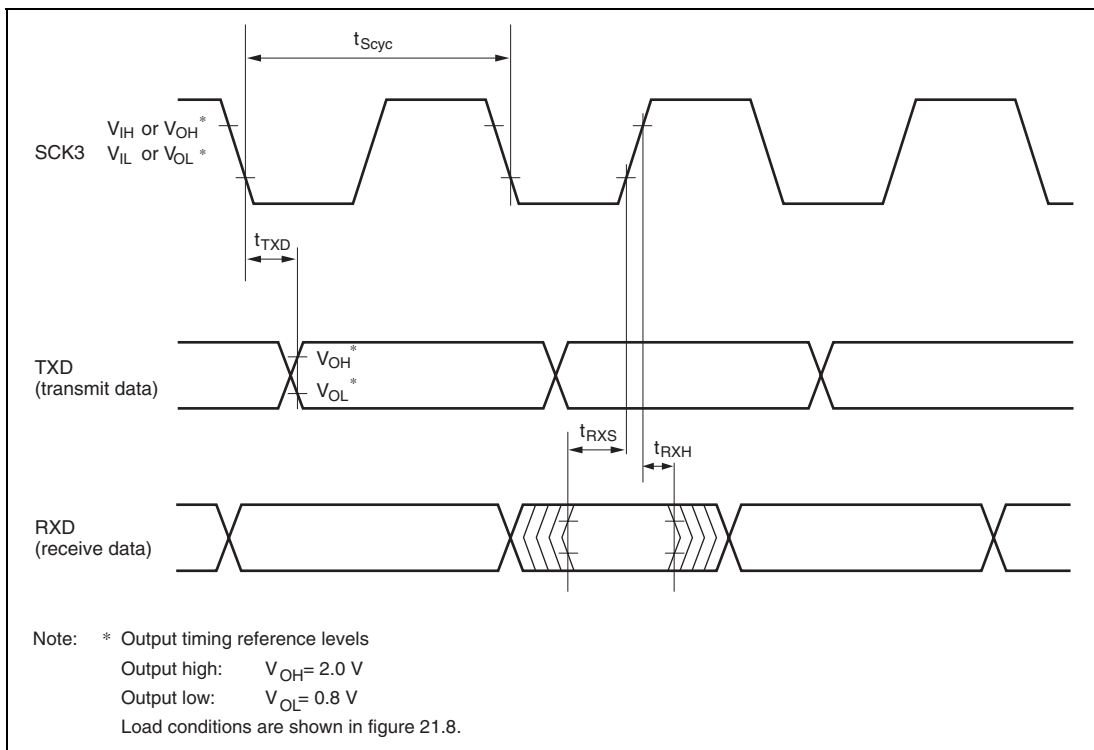

Figure 21.6 SCI Input/Output Timing in Clocked Synchronous Mode

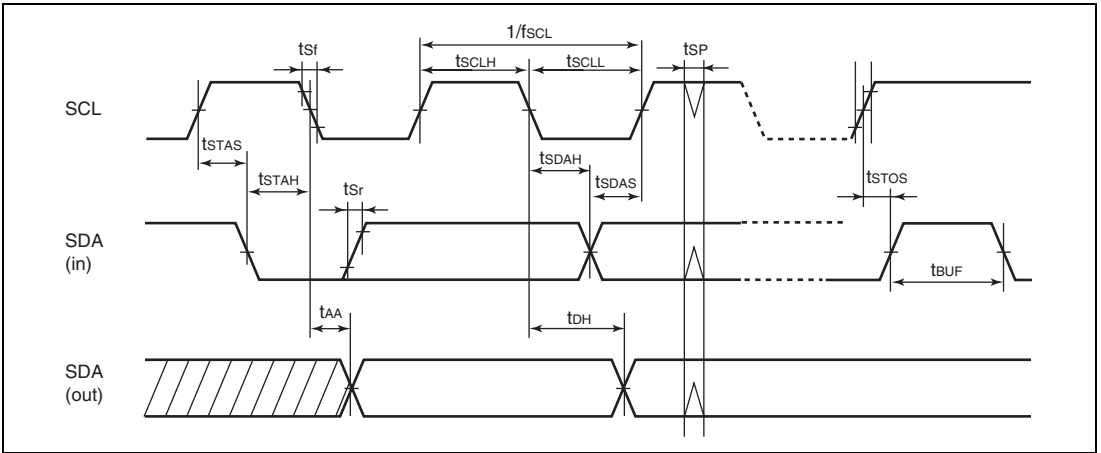

Figure 21.7 EEPROM Bus Timing

21.5 Output Load Condition

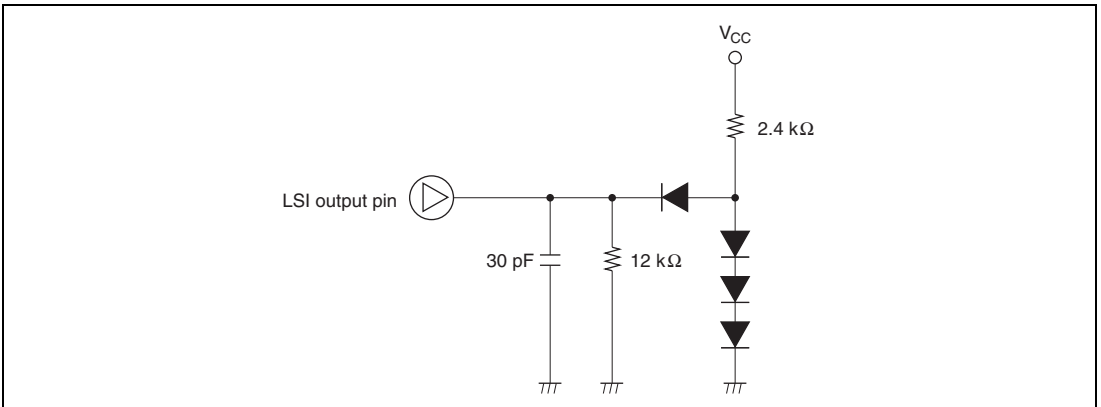

Figure 21.8 Output Load Circuit

Appendix A Instruction Set

A.1 Instruction List

Condition Code

| Symbol | Description |
|----------|---|
| Rd | General destination register |
| Rs | General source register |
| Rn | General register |
| ERd | General destination register (address register or 32-bit register) |
| ERs | General source register (address register or 32-bit register) |
| ERn | General register (32-bit register) |
| (EAd) | Destination operand |
| (EAs) | Source operand |
| PC | Program counter |
| SP | Stack pointer |
| CCR | Condition-code register |
| N | N (negative) flag in CCR |
| Z | Z (zero) flag in CCR |
| V | V (overflow) flag in CCR |
| C | C (carry) flag in CCR |
| disp | Displacement |
| → | Transfer from the operand on the left to the operand on the right, or transition from the state on the left to the state on the right |
| + | Addition of the operands on both sides |
| – | Subtraction of the operand on the right from the operand on the left |
| × | Multiplication of the operands on both sides |
| ÷ | Division of the operand on the left by the operand on the right |
| ^ | Logical AND of the operands on both sides |
| ∨ | Logical OR of the operands on both sides |
| ⊕ | Logical exclusive OR of the operands on both sides |
| ¬ | NOT (logical complement) |
| (), < > | Contents of operand |

Note: General registers include 8-bit registers (R0H to R7H and R0L to R7L) and 16-bit registers (R0 to R7 and E0 to E7).

Condition Code Notation (cont)

| Symbol | Description |
|---------------|--|
| ↕ | Changed according to execution result |
| * | Undetermined (no guaranteed value) |
| 0 | Cleared to 0 |
| 1 | Set to 1 |
| — | Not affected by execution of the instruction |
| Δ | Varies depending on conditions, described in notes |

Table A.1 Instruction Set

1. Data Transfer Instructions

| Mnemonic | | Operand Size | Addressing Mode and Instruction Length (bytes) | | | | | | | Operation | Condition Code | | | | | | No. of States ^{*1} | | | |
|------------------------|------------------------|--------------|--|----|------|------------|-------------|-----|-----------|-----------|----------------|---|---|---|---|---|-----------------------------|----|--------|----------|
| | | | #xx | Rn | @ERn | @ (d, ERn) | @-ERn/@ERn+ | @aa | @ (d, PC) | | @ @aa | I | I | H | N | Z | V | C | Normal | Advanced |
| | | | | | | | | | | | | | | | | | | | | |
| MOV | MOV.B #xx:8, Rd | B | 2 | | | | | | | | | | | | | | | 2 | | |
| | MOV.B Rs, Rd | B | | 2 | | | | | | | | | | | | | | 2 | | |
| | MOV.B @ERs, Rd | B | | | 2 | | | | | | | | | | | | | 4 | | |
| | MOV.B @(d:16, ERs), Rd | B | | | | 4 | | | | | | | | | | | | 6 | | |
| | MOV.B @(d:24, ERs), Rd | B | | | | | 8 | | | | | | | | | | | 10 | | |
| | MOV.B @ERs+, Rd | B | | | | | | 2 | | | | | | | | | | 6 | | |
| | MOV.B @aa:8, Rd | B | | | | | | | 2 | | | | | | | | | 4 | | |
| | MOV.B @aa:16, Rd | B | | | | | | | | 4 | | | | | | | | 6 | | |
| | MOV.B @aa:24, Rd | B | | | | | | | | | 6 | | | | | | | 8 | | |
| | MOV.B Rs, @ERd | B | | | 2 | | | | | | | | | | | | | 4 | | |
| | MOV.B Rs, @(d:16, ERd) | B | | | | 4 | | | | | | | | | | | | 6 | | |
| | MOV.B Rs, @(d:24, ERd) | B | | | | | 8 | | | | | | | | | | | 10 | | |
| | MOV.B Rs, @-ERd | B | | | | | | 2 | | | | | | | | | | 6 | | |
| | MOV.B Rs, @aa:8 | B | | | | | | | | 2 | | | | | | | | 4 | | |
| | MOV.B Rs, @aa:16 | B | | | | | | | | | 4 | | | | | | | 6 | | |
| | MOV.B Rs, @aa:24 | B | | | | | | | | | | 6 | | | | | | 8 | | |
| | MOV.W #xx:16, Rd | W | 4 | | | | | | | | | | | | | | | 4 | | |
| | MOV.W Rs, Rd | W | | 2 | | | | | | | | | | | | | | 2 | | |
| | MOV.W @ERs, Rd | W | | | 2 | | | | | | | | | | | | | 4 | | |
| | MOV.W @(d:16, ERs), Rd | W | | | | 4 | | | | | | | | | | | | 6 | | |
| | MOV.W @(d:24, ERs), Rd | W | | | | | 8 | | | | | | | | | | | 10 | | |
| MOV.W @ERs+, Rd | W | | | | | | 2 | | | | | | | | | | 6 | | | |
| MOV.W @aa:16, Rd | W | | | | | | | | | | 4 | | | | | | 6 | | | |
| MOV.W @aa:24, Rd | W | | | | | | | | | | | 6 | | | | | 8 | | | |
| MOV.W Rs, @ERd | W | | | 2 | | | | | | | | | | | | | 4 | | | |
| MOV.W Rs, @(d:16, ERd) | W | | | | 4 | | | | | | | | | | | | 6 | | | |
| MOV.W Rs, @(d:24, ERd) | W | | | | | 8 | | | | | | | | | | | 10 | | | |

2. Arithmetic Instructions

| | Mnemonic | Operand Size | Addressing Mode and Instruction Length (bytes) | | | | | | | Operation | Condition Code | | | | | | No. of States ^{*1} | | | |
|----------------|-------------------|--------------|--|----|------|------------|-------------|-----|-----------|-----------|----------------|-----|---|-----|-----|---|-----------------------------|---|--------|----------|
| | | | #xx | Rn | @ERn | @ (d, ERn) | @-ERn/@ERn+ | @aa | @ (d, PC) | | @@aa | | I | H | N | Z | V | C | Normal | Advanced |
| | | | | | | | | | | | | | | | | | | | | |
| ADD | ADD.B #xx:8, Rd | B | 2 | | | | | | | | | | | | | | | 2 | | |
| | ADD.B Rs, Rd | B | 2 | | | | | | | | | | | | | | | 2 | | |
| | ADD.W #xx:16, Rd | W | 4 | | | | | | | | | (1) | ↑ | ↑ | ↑ | ↑ | ↑ | 4 | | |
| | ADD.W Rs, Rd | W | 2 | | | | | | | | | (1) | ↑ | ↑ | ↑ | ↑ | ↑ | 2 | | |
| | ADD.L #xx:32, ERd | L | 6 | | | | | | | | | (2) | ↑ | ↑ | ↑ | ↑ | ↑ | 6 | | |
| ADD.L ERs, ERd | L | 2 | | | | | | | | | (2) | ↑ | ↑ | ↑ | ↑ | ↑ | 2 | | | |
| ADDX | ADDX.B #xx:8, Rd | B | 2 | | | | | | | | | ↑ | ↑ | (3) | ↑ | ↑ | 2 | | | |
| | ADDX.B Rs, Rd | B | 2 | | | | | | | | | ↑ | ↑ | (3) | ↑ | ↑ | 2 | | | |
| ADDS | ADDS.L #1, ERd | L | 2 | | | | | | | | | — | — | — | — | — | — | 2 | | |
| | ADDS.L #2, ERd | L | 2 | | | | | | | | | — | — | — | — | — | — | 2 | | |
| | ADDS.L #4, ERd | L | 2 | | | | | | | | | — | — | — | — | — | — | 2 | | |
| INC | INC.B Rd | B | 2 | | | | | | | | | — | — | ↑ | ↑ | ↑ | — | 2 | | |
| | INC.W #1, Rd | W | 2 | | | | | | | | | — | — | ↑ | ↑ | ↑ | — | 2 | | |
| | INC.W #2, Rd | W | 2 | | | | | | | | | — | — | ↑ | ↑ | ↑ | — | 2 | | |
| | INC.L #1, ERd | L | 2 | | | | | | | | | — | — | ↑ | ↑ | ↑ | — | 2 | | |
| | INC.L #2, ERd | L | 2 | | | | | | | | | — | — | ↑ | ↑ | ↑ | — | 2 | | |
| DAA | DAA Rd | B | 2 | | | | | | | | | — | * | ↑ | ↑ | * | — | 2 | | |
| SUB | SUB.B Rs, Rd | B | 2 | | | | | | | | | — | ↑ | ↑ | ↑ | ↑ | ↑ | 2 | | |
| | SUB.W #xx:16, Rd | W | 4 | | | | | | | | | (1) | ↑ | ↑ | ↑ | ↑ | ↑ | 4 | | |
| | SUB.W Rs, Rd | W | 2 | | | | | | | | | (1) | ↑ | ↑ | ↑ | ↑ | ↑ | 2 | | |
| | SUB.L #xx:32, ERd | L | 6 | | | | | | | | | (2) | ↑ | ↑ | ↑ | ↑ | ↑ | 6 | | |
| | SUB.L ERs, ERd | L | 2 | | | | | | | | | (2) | ↑ | ↑ | ↑ | ↑ | ↑ | 2 | | |
| SUBX | SUBX.B #xx:8, Rd | B | 2 | | | | | | | | | — | ↑ | ↑ | (3) | ↑ | ↑ | 2 | | |
| | SUBX.B Rs, Rd | B | 2 | | | | | | | | | — | ↑ | ↑ | (3) | ↑ | ↑ | 2 | | |
| SUBS | SUBS.L #1, ERd | L | 2 | | | | | | | | | — | — | — | — | — | — | 2 | | |
| | SUBS.L #2, ERd | L | 2 | | | | | | | | | — | — | — | — | — | — | 2 | | |
| | SUBS.L #4, ERd | L | 2 | | | | | | | | | — | — | — | — | — | — | 2 | | |
| DEC | DEC.B Rd | B | 2 | | | | | | | | | — | — | ↑ | ↑ | ↑ | — | 2 | | |
| | DEC.W #1, Rd | W | 2 | | | | | | | | | — | — | ↑ | ↑ | ↑ | — | 2 | | |
| | DEC.W #2, Rd | W | 2 | | | | | | | | | — | — | ↑ | ↑ | ↑ | — | 2 | | |

| Mnemonic | | Operand Size | Addressing Mode and Instruction Length (bytes) | | | | | | | | Operation | Condition Code | | | | | | No. of States ^{*1} | | | | |
|----------|-------------------|--------------|--|----|------|-----------|-------------|-----|----------|------|-----------|----------------|---|---|---|---|---|-----------------------------|--------|----------|---|----|
| | | | #xx | Rn | @ERn | @{d, ERn} | @-ERn/@ERn+ | @aa | @{d, PC} | @@aa | | | I | H | N | Z | V | C | Normal | Advanced | | |
| | | | | | | | | | | | | | | | | | | | | | | |
| DEC | DEC.L #1, ERd | L | 2 | | | | | | | | | | | | | | | | | | 2 | |
| | DEC.L #2, ERd | L | 2 | | | | | | | | | | | | | | | | | | | 2 |
| DAS | DAS.Rd | B | 2 | | | | | | | | | | | | | | | | | | | 2 |
| MULXU | MULXU. B Rs, Rd | B | 2 | | | | | | | | | | | | | | | | | | | 14 |
| | MULXU. W Rs, ERd | W | 2 | | | | | | | | | | | | | | | | | | | 22 |
| MULXS | MULXS. B Rs, Rd | B | 4 | | | | | | | | | | | | | | | | | | | 16 |
| | MULXS. W Rs, ERd | W | 4 | | | | | | | | | | | | | | | | | | | 24 |
| DIVXU | DIVXU. B Rs, Rd | B | 2 | | | | | | | | | | | | | | | | | | | 14 |
| | DIVXU. W Rs, ERd | W | 2 | | | | | | | | | | | | | | | | | | | 22 |
| DIVXS | DIVXS. B Rs, Rd | B | 4 | | | | | | | | | | | | | | | | | | | 16 |
| | DIVXS. W Rs, ERd | W | 4 | | | | | | | | | | | | | | | | | | | 24 |
| CMP | CMP.B #xx:8, Rd | B | 2 | | | | | | | | | | | | | | | | | | | 2 |
| | CMP.B Rs, Rd | B | 2 | | | | | | | | | | | | | | | | | | | 2 |
| | CMP.W #xx:16, Rd | W | 4 | | | | | | | | | | | | | | | | | | | 4 |
| | CMP.W Rs, Rd | W | 2 | | | | | | | | | | | | | | | | | | | 2 |
| | CMP.L #xx:32, ERd | L | 6 | | | | | | | | | | | | | | | | | | | 4 |
| | CMP.L ERs, ERd | L | 2 | | | | | | | | | | | | | | | | | | | |

| Mnemonic | | Operand Size | Addressing Mode and Instruction Length (bytes) | | | | | | | | Operation | Condition Code | | | | | | No. of States ^{*1} | | |
|----------|------------|--------------|--|----|------|------------|-------------|-----|-----------|------|-----------|----------------|---|---|---|---|---|-----------------------------|--------|----------|
| | | | #xx | Rn | @ERn | @ (d, ERn) | @-ERn/@ERn+ | @aa | @ (d, PC) | @@aa | | I | I | H | N | Z | V | C | Normal | Advanced |
| | | | | | | | | | | | | | | | | | | | | |
| NEG | NEG.B Rd | B | 2 | | | | | | | | | | | | | | | 2 | | |
| | NEG.W Rd | W | 2 | | | | | | | | | | | | | | | 2 | | |
| | NEG.L ERd | L | 2 | | | | | | | | | | | | | | | 2 | | |
| EXTU | EXTU.W Rd | W | 2 | | | | | | | | | | 0 | ↓ | 0 | — | | 2 | | |
| | EXTU.L ERd | L | 2 | | | | | | | | | | 0 | ↓ | 0 | — | | 2 | | |
| EXTS | EXTS.W Rd | W | 2 | | | | | | | | | | ↓ | ↓ | 0 | — | | 2 | | |
| | EXTS.L ERd | L | 2 | | | | | | | | | | ↓ | ↓ | 0 | — | | 2 | | |

3. Logic Instructions

| Mnemonic | | Operand Size | Addressing Mode and Instruction Length (bytes) | | | | | | | | Operation | Condition Code | | | | | | No. of States ^{*1} | | |
|----------|-------------------|--------------|--|----|------|------------|-------------|-----|-----------|------|-----------|----------------|---|---|---|---|---|-----------------------------|--------|----------|
| | | | #xx | Rn | @ERn | @ (d, ERn) | @-ERn/@ERn+ | @aa | @ (d, PC) | @@aa | | | I | H | N | Z | V | C | Normal | Advanced |
| | | | | | | | | | | | | | | | | | | | | |
| AND | AND.B #xx:8, Rd | B | 2 | | | | | | | | | | | | | | | 2 | | |
| | AND.B Rs, Rd | B | 2 | | | | | | | | | | | | | | | 2 | | |
| | AND.W #xx:16, Rd | W | 4 | | | | | | | | | | | | | | | 4 | | |
| | AND.W Rs, Rd | W | 2 | | | | | | | | | | | | | | | 2 | | |
| | AND.L #xx:32, ERd | L | 6 | | | | | | | | | | | | | | | 6 | | |
| | AND.L ERs, ERd | L | 4 | | | | | | | | | | | | | | | 4 | | |
| OR | OR.B #xx:8, Rd | B | 2 | | | | | | | | | | | | | | | 2 | | |
| | OR.B Rs, Rd | B | 2 | | | | | | | | | | | | | | | 2 | | |
| | OR.W #xx:16, Rd | W | 4 | | | | | | | | | | | | | | | 4 | | |
| | OR.W Rs, Rd | W | 2 | | | | | | | | | | | | | | | 2 | | |
| | OR.L #xx:32, ERd | L | 6 | | | | | | | | | | | | | | | 6 | | |
| | OR.L ERs, ERd | L | 4 | | | | | | | | | | | | | | | 4 | | |
| XOR | XOR.B #xx:8, Rd | B | 2 | | | | | | | | | | | | | | | 2 | | |
| | XOR.B Rs, Rd | B | 2 | | | | | | | | | | | | | | | 2 | | |
| | XOR.W #xx:16, Rd | W | 4 | | | | | | | | | | | | | | | 4 | | |
| | XOR.W Rs, Rd | W | 2 | | | | | | | | | | | | | | | 2 | | |
| | XOR.L #xx:32, ERd | L | 6 | | | | | | | | | | | | | | | 6 | | |
| | XOR.L ERs, ERd | L | 4 | | | | | | | | | | | | | | | 4 | | |
| NOT | NOT.B Rd | B | 2 | | | | | | | | | | | | | | | 2 | | |
| | NOT.W Rd | W | 2 | | | | | | | | | | | | | | | 2 | | |
| | NOT.L ERd | L | 2 | | | | | | | | | | | | | | | 2 | | |

| Mnemonic | | Addressing Mode and Instruction Length (bytes) | | | | | | | | Operation | Condition Code | | | | | | No. of States ^{*1} | | | |
|----------|--------------------|--|-----|----|------|------------|-------------|-----|-----------|-----------|----------------|--|---|---|---|---|-----------------------------|---|--------|----------|
| | | Operand Size | #xx | Rn | @ERn | @ (d, ERn) | @-ERn/@ERN+ | @aa | @ (d, PC) | | @aa | | I | H | N | Z | V | C | Normal | Advanced |
| | | | | | | | | | | | | | | | | | | | | |
| BLD | BLD #xx:3, @ERd | B | | 4 | | | | | | | | | | | | ↑ | 6 | | | |
| | BLD #xx:3, @aa:8 | B | | | | | 4 | | | | | | | | | ↑ | 6 | | | |
| BILD | BILD #xx:3, Rd | B | 2 | | | | | | | | | | | | | ↑ | 2 | | | |
| | BILD #xx:3, @ERd | B | | 4 | | | | | | | | | | | | ↑ | 6 | | | |
| | BILD #xx:3, @aa:8 | B | | | | | 4 | | | | | | | | | ↑ | 6 | | | |
| BST | BST #xx:3, Rd | B | 2 | | | | | | | | | | | | | | 2 | | | |
| | BST #xx:3, @ERd | B | | 4 | | | | | | | | | | | | | 8 | | | |
| | BST #xx:3, @aa:8 | B | | | | | 4 | | | | | | | | | | 8 | | | |
| BIST | BIST #xx:3, Rd | B | 2 | | | | | | | | | | | | | | 2 | | | |
| | BIST #xx:3, @ERd | B | | 4 | | | | | | | | | | | | | 8 | | | |
| | BIST #xx:3, @aa:8 | B | | | | | 4 | | | | | | | | | | 8 | | | |
| BAND | BAND #xx:3, Rd | B | 2 | | | | | | | | | | | | | ↑ | 2 | | | |
| | BAND #xx:3, @ERd | B | | 4 | | | | | | | | | | | | ↑ | 6 | | | |
| | BAND #xx:3, @aa:8 | B | | | | | 4 | | | | | | | | | ↑ | 6 | | | |
| BIAND | BIAND #xx:3, Rd | B | 2 | | | | | | | | | | | | | ↑ | 2 | | | |
| | BIAND #xx:3, @ERd | B | | 4 | | | | | | | | | | | | ↑ | 6 | | | |
| | BIAND #xx:3, @aa:8 | B | | | | | 4 | | | | | | | | | ↑ | 6 | | | |
| BOR | BOR #xx:3, Rd | B | 2 | | | | | | | | | | | | | ↑ | 2 | | | |
| | BOR #xx:3, @ERd | B | | 4 | | | | | | | | | | | | ↑ | 6 | | | |
| | BOR #xx:3, @aa:8 | B | | | | | 4 | | | | | | | | | ↑ | 6 | | | |
| BIOR | BIOR #xx:3, Rd | B | 2 | | | | | | | | | | | | | ↑ | 2 | | | |
| | BIOR #xx:3, @ERd | B | | 4 | | | | | | | | | | | | ↑ | 6 | | | |
| | BIOR #xx:3, @aa:8 | B | | | | | 4 | | | | | | | | | ↑ | 6 | | | |
| BXOR | BXOR #xx:3, Rd | B | 2 | | | | | | | | | | | | | ↑ | 2 | | | |
| | BXOR #xx:3, @ERd | B | | 4 | | | | | | | | | | | | ↑ | 6 | | | |
| | BXOR #xx:3, @aa:8 | B | | | | | 4 | | | | | | | | | ↑ | 6 | | | |
| BIXOR | BIXOR #xx:3, Rd | B | 2 | | | | | | | | | | | | | ↑ | 2 | | | |
| | BIXOR #xx:3, @ERd | B | | 4 | | | | | | | | | | | | ↑ | 6 | | | |
| | BIXOR #xx:3, @aa:8 | B | | | | | 4 | | | | | | | | | ↑ | 6 | | | |

6. Branching Instructions

| Mnemonic | | Addressing Mode and Instruction Length (bytes) | | | | | | | | | Operation | Condition Code | | | | | | No. of States ^{*1} | | | |
|----------|---------------------|--|-----|----|-------|------------|---------------|------|-----------|-------|--|----------------|------------------|---|---|---|---|-----------------------------|---|--------|----------|
| | | Operand Size | #xx | Rn | @ ERn | @ (d, ERn) | @ -ERn/@ ERn+ | @ aa | @ (d, PC) | @ @aa | | | Branch Condition | I | H | N | Z | V | C | Normal | Advanced |
| | | | | | | | | | | | | | | | | | | | | | |
| Bcc | BRA d:8 (BT d:8) | — | | | | | | | | 2 | If condition is true then PC ← PC+d else next; | Always | — | — | — | — | — | — | 4 | | |
| | BRA d:16 (BT d:16) | — | | | | | | | | 4 | | | — | — | — | — | — | — | 6 | | |
| | BRN d:8 (BF d:8) | — | | | | | | | | 2 | | | Never | — | — | — | — | — | — | 4 | |
| | BRN d:16 (BF d:16) | — | | | | | | | | 4 | | | | — | — | — | — | — | — | 6 | |
| | BHI d:8 | — | | | | | | | | 2 | | | Cv Z = 0 | — | — | — | — | — | — | 4 | |
| | BHI d:16 | — | | | | | | | | 4 | | | | — | — | — | — | — | — | 6 | |
| | BLS d:8 | — | | | | | | | | 2 | | | Cv Z = 1 | — | — | — | — | — | — | 4 | |
| | BLS d:16 | — | | | | | | | | 4 | | | | — | — | — | — | — | — | 6 | |
| | BCC d:8 (BHS d:8) | — | | | | | | | | 2 | | | C = 0 | — | — | — | — | — | — | 4 | |
| | BCC d:16 (BHS d:16) | — | | | | | | | | 4 | | | | — | — | — | — | — | — | 6 | |
| | BCS d:8 (BLO d:8) | — | | | | | | | | 2 | | | C = 1 | — | — | — | — | — | — | 4 | |
| | BCS d:16 (BLO d:16) | — | | | | | | | | 4 | | | | — | — | — | — | — | — | 6 | |
| | BNE d:8 | — | | | | | | | | 2 | | | Z = 0 | — | — | — | — | — | — | 4 | |
| | BNE d:16 | — | | | | | | | | 4 | | | | — | — | — | — | — | — | 6 | |
| | BEQ d:8 | — | | | | | | | | 2 | | | Z = 1 | — | — | — | — | — | — | 4 | |
| | BEQ d:16 | — | | | | | | | | 4 | | | | — | — | — | — | — | — | 6 | |
| | BVC d:8 | — | | | | | | | | 2 | | | V = 0 | — | — | — | — | — | — | 4 | |
| | BVC d:16 | — | | | | | | | | 4 | | | | — | — | — | — | — | — | 6 | |
| | BVS d:8 | — | | | | | | | | 2 | | | V = 1 | — | — | — | — | — | — | 4 | |
| | BVS d:16 | — | | | | | | | | 4 | | | | — | — | — | — | — | — | 6 | |
| | BPL d:8 | — | | | | | | | | 2 | | | N = 0 | — | — | — | — | — | — | 4 | |
| | BPL d:16 | — | | | | | | | | 4 | | | | — | — | — | — | — | — | 6 | |
| | BMI d:8 | — | | | | | | | | 2 | | | N = 1 | — | — | — | — | — | — | 4 | |
| | BMI d:16 | — | | | | | | | | 4 | | | | — | — | — | — | — | — | 6 | |
| | BGE d:8 | — | | | | | | | | 2 | | | N⊕V = 0 | — | — | — | — | — | — | 4 | |
| | BGE d:16 | — | | | | | | | | 4 | | | | — | — | — | — | — | — | 6 | |
| | BLT d:8 | — | | | | | | | | 2 | | | N⊕V = 1 | — | — | — | — | — | — | 4 | |
| | BLT d:16 | — | | | | | | | | 4 | | | | — | — | — | — | — | — | 6 | |
| | BGT d:8 | — | | | | | | | | 2 | | | Zv (N⊕V) = 0 | — | — | — | — | — | — | 4 | |
| | BGT d:16 | — | | | | | | | | 4 | | | | — | — | — | — | — | — | 6 | |
| | BLE d:8 | — | | | | | | | | 2 | | | Zv (N⊕V) = 1 | — | — | — | — | — | — | 4 | |
| | BLE d:16 | — | | | | | | | | 4 | | | | — | — | — | — | — | — | 6 | |

| Mnemonic | | Operand Size | Addressing Mode and Instruction Length (bytes) | | | | | | | | Operation | Condition Code | | | | | | No. of States ^{*1} | | |
|----------|-------------|--------------|--|----|------|------------|--------------|-----|-----------|-------|-----------|----------------|---|---|---|---|---|-----------------------------|--------|----------|
| | | | #xx | Rn | @ERn | @ (d, ERn) | @ -ERn/@ERn+ | @aa | @ (d, PC) | @ @aa | | | I | H | N | Z | V | C | Normal | Advanced |
| | | | | | | | | | | | | | | | | | | | | |
| JMP | JMP @ERn | — | | | 2 | | | | | | | | | | | | | 4 | | |
| | JMP @aa:24 | — | | | | | | 4 | | | | | | | | | | 6 | | |
| | JMP @ @aa:8 | — | | | | | | | | 2 | | | | | | | | 8 10 | | |
| BSR | BSR d:8 | — | | | | | | | | 2 | | | | | | | | 6 8 | | |
| | BSR d:16 | — | | | | | | | | 4 | | | | | | | | 8 10 | | |
| JSR | JSR @ERn | — | | | 2 | | | | | | | | | | | | | 6 8 | | |
| | JSR @aa:24 | — | | | | | | 4 | | | | | | | | | | 8 10 | | |
| | JSR @ @aa:8 | — | | | | | | | | 2 | | | | | | | | 8 12 | | |
| RTS | RTS | — | | | | | | | | 2 | | | | | | | | 8 10 | | |

7. System Control Instructions

| Mnemonic | | Operand Size | Addressing Mode and Instruction Length (bytes) | | | | | | | | Operation | Condition Code | | | | | | No. of States ^{*1} | | | |
|-----------------|-----------------------|--------------|--|----|------|------------|-------------|-----|-----------|------|--------------|--|---|---|---|---|---|-----------------------------|--------|----------|----|
| | | | #xx | Rn | @ERn | @ (d, ERn) | @-ERn/@ERn+ | @aa | @ (d, PC) | @@aa | | | I | H | N | Z | V | C | Normal | Advanced | |
| | | | | | | | | | | | | | | | | | | | | | |
| TRAPA | TRAPA #x:2 | — | | | | | | | | | 2 | PC → @-SP CCR → @-SP <vector> → PC | 1 | — | — | — | — | — | — | 14 | 16 |
| RTE | RTE | — | | | | | | | | | | CCR ← @SP+ PC ← @SP+ | ↑ | ↑ | ↑ | ↑ | ↑ | ↑ | ↑ | 10 | |
| SLEEP | SLEEP | — | | | | | | | | | | Transition to power-down state | — | — | — | — | — | — | — | 2 | |
| LDC | LDC #xx:8, CCR | B | 2 | | | | | | | | | #xx:8 → CCR | ↑ | ↑ | ↑ | ↑ | ↑ | ↑ | ↑ | 2 | |
| | LDC Rs, CCR | B | 2 | | | | | | | | | Rs8 → CCR | ↑ | ↑ | ↑ | ↑ | ↑ | ↑ | ↑ | 2 | |
| | LDC @ERs, CCR | W | | 4 | | | | | | | | @ERs → CCR | ↑ | ↑ | ↑ | ↑ | ↑ | ↑ | ↑ | 6 | |
| | LDC @(d:16, ERs), CCR | W | | | 6 | | | | | | | @(d:16, ERs) → CCR | ↑ | ↑ | ↑ | ↑ | ↑ | ↑ | ↑ | 8 | |
| | LDC @(d:24, ERs), CCR | W | | | | 10 | | | | | | @(d:24, ERs) → CCR | ↑ | ↑ | ↑ | ↑ | ↑ | ↑ | ↑ | 12 | |
| | LDC @ERs+, CCR | W | | | | | 4 | | | | | @ERs → CCR ERs32+2 → ERs32 | ↑ | ↑ | ↑ | ↑ | ↑ | ↑ | ↑ | 8 | |
| | LDC @aa:16, CCR | W | | | | | | 6 | | | | @aa:16 → CCR | ↑ | ↑ | ↑ | ↑ | ↑ | ↑ | ↑ | 8 | |
| LDC @aa:24, CCR | W | | | | | | | 8 | | | @aa:24 → CCR | ↑ | ↑ | ↑ | ↑ | ↑ | ↑ | ↑ | 10 | | |
| STC | STC CCR, Rd | B | 2 | | | | | | | | | CCR → Rd8 | — | — | — | — | — | — | — | 2 | |
| | STC CCR, @ERd | W | | 4 | | | | | | | | CCR → @ERd | — | — | — | — | — | — | — | 6 | |
| | STC CCR, @(d:16, ERd) | W | | | 6 | | | | | | | CCR → @(d:16, ERd) | — | — | — | — | — | — | — | 8 | |
| | STC CCR, @(d:24, ERd) | W | | | | 10 | | | | | | CCR → @(d:24, ERd) | — | — | — | — | — | — | — | 12 | |
| | STC CCR, @-ERd | W | | | | | 4 | | | | | ERd32-2 → ERd32 CCR → @ERd | — | — | — | — | — | — | — | 8 | |
| | STC CCR, @aa:16 | W | | | | | | 6 | | | | CCR → @aa:16 | — | — | — | — | — | — | — | 8 | |
| | STC CCR, @aa:24 | W | | | | | | | 8 | | | CCR → @aa:24 | — | — | — | — | — | — | — | 10 | |
| ANDC | ANDC #xx:8, CCR | B | 2 | | | | | | | | | CCR^#xx:8 → CCR | ↑ | ↑ | ↑ | ↑ | ↑ | ↑ | ↑ | 2 | |
| ORC | ORC #xx:8, CCR | B | 2 | | | | | | | | | CCRV#xx:8 → CCR | ↑ | ↑ | ↑ | ↑ | ↑ | ↑ | ↑ | 2 | |
| XORC | XORC #xx:8, CCR | B | 2 | | | | | | | | | CCR@#xx:8 → CCR | ↑ | ↑ | ↑ | ↑ | ↑ | ↑ | ↑ | 2 | |
| NOP | NOP | — | | | | | | | | | 2 | PC ← PC+2 | — | — | — | — | — | — | — | 2 | |

8. Block Transfer Instructions

| Mnemonic | Addressing Mode and Instruction Length (bytes) | | | | | | | | Operation | Condition Code | | | | | | No. of States ^{*1} | | | |
|----------|--|-----|----|------|------------|-------------|-----|-----------|-----------|----------------|--|---|---|---|---|-----------------------------|---|------------------------|----------|
| | Operand Size | #xx | Rn | @ERn | @ (d, ERn) | @-ERn/@ERn+ | @aa | @ (d, PC) | | @ @aa | | I | H | N | Z | V | C | Normal | Advanced |
| | | | | | | | | | | | | | | | | | | | |
| EEPMOV | EEPMOV. B | — | | | | | | | | 4 | if R4L ≠ 0 then repeat @R5 → @R6 R5+1 → R5 R6+1 → R6 R4L-1 → R4L until R4L=0 else next | — | — | — | — | — | — | 8+ 4n ^{*2} | |
| | EEPMOV. W | — | | | | | | | | 4 | if R4 ≠ 0 then repeat @R5 → @R6 R5+1 → R5 R6+1 → R6 R4-1 → R4 until R4=0 else next | — | — | — | — | — | — | 8+ 4n ^{*2} | |

- Notes: 1. The number of states in cases where the instruction code and its operands are located in on-chip memory is shown here. For other cases see appendix A.3, Number of Execution States.
2. n is the value set in register R4L or R4.
- (1) Set to 1 when a carry or borrow occurs at bit 11; otherwise cleared to 0.
 - (2) Set to 1 when a carry or borrow occurs at bit 27; otherwise cleared to 0.
 - (3) Retains its previous value when the result is zero; otherwise cleared to 0.
 - (4) Set to 1 when the adjustment produces a carry; otherwise retains its previous value.
 - (5) The number of states required for execution of an instruction that transfers data in synchronization with the E clock is variable.
 - (6) Set to 1 when the divisor is negative; otherwise cleared to 0.
 - (7) Set to 1 when the divisor is zero; otherwise cleared to 0.
 - (8) Set to 1 when the quotient is negative; otherwise cleared to 0.

A.2 Operation Code Map

Table A.2 Operation Code Map (1)

Instruction code:

| | | | |
|----------|----|----------|----|
| 1st byte | | 2nd byte | |
| AH | AL | BH | BL |

| AL / AH | 0 | 1 | 2 | 3 | 4 | 5 | 6 | 7 | 8 | 9 | A | B | C | D | E | F |
|---------|---------------|---------------|---------------|---------------|-------|--------|--------|---------------|---------------|---------------|---------------|---------------|---------------|-----|------|---------------|
| 0 | NOP | Table A-2 (2) | STC | LDC | ORC | XORC | ANDC | LDC | ADD | ADD | Table A-2 (2) | Table A-2 (2) | Table A-2 (2) | MOV | ADDX | Table A-2 (2) |
| 1 | Table A-2 (2) | Table A-2 (2) | Table A-2 (2) | Table A-2 (2) | ORL.B | XORL.B | ANDL.B | Table A-2 (2) | SUB | SUB | Table A-2 (2) | Table A-2 (2) | CMP | CMP | SUBX | Table A-2 (2) |
| 2 | MOV.B | | | | | | | | | | | | | | | |
| 3 | MOV | | | | | | | | | | | | | | | |
| 4 | BRA | BRN | BHI | BLS | BCC | BCS | BNE | BEQ | BVC | BVS | BPL | BMI | BGE | BLT | BGT | BLE |
| 5 | MULXU | DIVXU | MULXU | DIVXU | RTS | BSR | RTE | TRAPA | Table A-2 (2) | JMP | JMP | BSR | BSR | JSR | | |
| 6 | BSET | BNOT | BCLR | BTST | BOR | BXOR | AND | BSL | MOV | | | | | | | |
| 7 | | | | | BIOR | BIXOR | BAND | BILD | MOV | Table A-2 (2) | Table A-2 (2) | EEMOV | Table A-2 (3) | | | |
| 8 | ADD | | | | | | | | | | | | | | | |
| 9 | ADDX | | | | | | | | | | | | | | | |
| A | CMP | | | | | | | | | | | | | | | |
| B | SUBX | | | | | | | | | | | | | | | |
| C | OR | | | | | | | | | | | | | | | |
| D | XOR | | | | | | | | | | | | | | | |
| E | AND | | | | | | | | | | | | | | | |
| F | MOV | | | | | | | | | | | | | | | |

Table A.2 Operation Code Map (2)

| | | 1st byte | | 2nd byte | | | | | | | | | | | | | | | | | | | |
|----|----|----------|-----|----------|-------|---------|-----|-----|------|-------|-----|-----|-----|-----|------------------|------------------|------------------|------|--|--|--|--|--|
| | | AH | AL | BH | BL | | | | | | | | | | | | | | | | | | |
| BH | AL | 0 | 1 | 2 | 3 | 4 | 5 | 6 | 7 | 8 | 9 | A | B | C | D | E | F | | | | | | |
| | 01 | MOV | | | | LDC/STC | | | | SLEEP | | | | | Table A-2 (3) | Table A-2 (3) | Table A-2 (3) | | | | | | |
| | 0A | INC | ADD | | | | | | | | | | | | | | | | | | | | |
| | 0B | ADDS | | | | | INC | | INC | ADDS | | | | | INC | | INC | | | | | | |
| | 0F | DAA | MOV | | | | | | | | | | | | | | | | | | | | |
| | 10 | SHLL | | | SHLL | | | | | SHAL | | | | | SHAL | | | | | | | | |
| | 11 | SHLR | | | SHLR | | | | | SHAR | | | | | SHAR | | | | | | | | |
| | 12 | ROTXL | | | ROTXL | | | | | ROTL | | | | | ROTL | | | | | | | | |
| | 13 | ROTXR | | | ROTXR | | | | | ROTR | | | | | ROTR | | | | | | | | |
| | 17 | NOT | | | NOT | | | | EXTU | NEG | | | | | NEG | | | EXTS | | | | | |
| | 1A | DEC | SUB | | | | | | | | | | | | | | | | | | | | |
| | 1B | SUBS | | | | | DEC | | DEC | SUB | | | | | DEC | | DEC | | | | | | |
| | 1F | DAS | CMP | | | | | | | | | | | | | | | | | | | | |
| | 58 | BRA | BRN | BHI | BLS | BCC | BCS | BNE | BEQ | BVC | BVS | BPL | BMI | BGE | BLT | BGT | BLE | | | | | | |
| | 79 | MOV | ADD | CMP | SUB | OR | XOR | AND | | | | | | | | | | | | | | | |
| | 7A | MOV | ADD | CMP | SUB | OR | XOR | AND | | | | | | | | | | | | | | | |

Instruction code:

| | |
|----------|----------|
| 1st byte | 2nd byte |
| AH AL | BH BL |

Table A.2 Operation Code Map (3)

| Instruction code: | | 1st byte | | 2nd byte | | 3rd byte | | 4th byte | |
|-------------------|----|----------|------|----------|-------|----------|------|----------|------|
| | | AH | AL | BH | BL | CH | CL | DH | DL |
| CL | 0 | | | | | | | | |
| AH | 1 | | | | | | | | |
| ALBH | 2 | | | | | | | | |
| BLCH | 3 | | | | | | | | |
| 01406 | 4 | | | | | | | | |
| 01C05 | 5 | MULXS | | | | | | | |
| 01D05 | 6 | DIVXS | | | | | | | |
| 01F06 | 7 | | | OR | XOR | AND | | | |
| 7C06*1 | 8 | BTST | | | | | | | |
| 7C07*1 | 9 | BTST | | BOR | BXOR | BAND | BLD | BILD | BIST |
| 7D06*1 | 10 | BSET | BNOT | BIOR | BIXOR | BIAND | BIST | BIST | BIST |
| 7D07*1 | 11 | BSET | BNOT | BCLR | | | | | |
| 7Eaa6*2 | 12 | BTST | | | | | | | |
| 7Eaa7*2 | 13 | BTST | | BOR | BXOR | BAND | BLD | BILD | BIST |
| 7Faaf*2 | 14 | BSET | BNOT | BIOR | BIXOR | BIAND | BIST | BIST | BIST |
| 7Faaf*2 | 15 | BSET | BNOT | BCLR | | | | | |

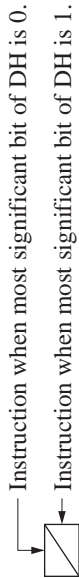

Notes: 1. r is the register designation field.
 2. aa is the absolute address field.

A.3 Number of Execution States

The status of execution for each instruction of the H8/300H CPU and the method of calculating the number of states required for instruction execution are shown below. Table A.4 shows the number of cycles of each type occurring in each instruction, such as instruction fetch and data read/write. Table A.3 shows the number of states required for each cycle. The total number of states required for execution of an instruction can be calculated by the following expression:

$$\text{Execution states} = I \times S_I + J \times S_J + K \times S_K + L \times S_L + M \times S_M + N \times S_N$$

Examples: When instruction is fetched from on-chip ROM, and an on-chip RAM is accessed.

BSET #0, @FF00

From table A.4:

$$I = L = 2, \quad J = K = M = N = 0$$

From table A.3:

$$S_I = 2, \quad S_L = 2$$

$$\text{Number of states required for execution} = 2 \times 2 + 2 \times 2 = 8$$

When instruction is fetched from on-chip ROM, branch address is read from on-chip ROM, and on-chip RAM is used for stack area.

JSR @@ 30

From table A.4:

$$I = 2, \quad J = K = 1, \quad L = M = N = 0$$

From table A.3:

$$S_I = S_J = S_K = 2$$

$$\text{Number of states required for execution} = 2 \times 2 + 1 \times 2 + 1 \times 2 = 8$$

Table A.3 Number of Cycles in Each Instruction

| Execution Status (Instruction Cycle) | | Access Location | |
|---|-------|-----------------|---------------------------|
| | | On-Chip Memory | On-Chip Peripheral Module |
| Instruction fetch | S_I | 2 | — |
| Branch address read | S_J | | |
| Stack operation | S_K | | |
| Byte data access | S_L | | 2 or 3* |
| Word data access | S_M | | 2 or 3* |
| Internal operation | S_N | | 1 |

Note: * Depends on which on-chip peripheral module is accessed. See section 20.1, Register Addresses (Address Order).

Table A.4 Number of Cycles in Each Instruction

| Instruction | Mnemonic | Instruction | Branch | Stack | Byte Data | Word Data | Internal |
|-------------|-------------------|-------------|------------|-----------|-----------|-----------|-----------|
| | | Fetch | Addr. Read | Operation | Access | Access | Operation |
| | | I | J | K | L | M | N |
| ADD | ADD.B #xx:8, Rd | 1 | | | | | |
| | ADD.B Rs, Rd | 1 | | | | | |
| | ADD.W #xx:16, Rd | 2 | | | | | |
| | ADD.W Rs, Rd | 1 | | | | | |
| | ADD.L #xx:32, ERd | 3 | | | | | |
| | ADD.L ERs, ERd | 1 | | | | | |
| ADDS | ADDS #1/2/4, ERd | 1 | | | | | |
| ADDX | ADDX #xx:8, Rd | 1 | | | | | |
| | ADDX Rs, Rd | 1 | | | | | |
| AND | AND.B #xx:8, Rd | 1 | | | | | |
| | AND.B Rs, Rd | 1 | | | | | |
| | AND.W #xx:16, Rd | 2 | | | | | |
| | AND.W Rs, Rd | 1 | | | | | |
| | AND.L #xx:32, ERd | 3 | | | | | |
| | AND.L ERs, ERd | 2 | | | | | |
| ANDC | ANDC #xx:8, CCR | 1 | | | | | |
| BAND | BAND #xx:3, Rd | 1 | | | | | |
| | BAND #xx:3, @ERd | 2 | | | 1 | | |
| | BAND #xx:3, @aa:8 | 2 | | | 1 | | |
| Bcc | BRA d:8 (BT d:8) | 2 | | | | | |
| | BRN d:8 (BF d:8) | 2 | | | | | |
| | BHI d:8 | 2 | | | | | |
| | BLS d:8 | 2 | | | | | |
| | BCC d:8 (BHS d:8) | 2 | | | | | |
| | BCS d:8 (BLO d:8) | 2 | | | | | |
| | BNE d:8 | 2 | | | | | |
| | BEQ d:8 | 2 | | | | | |
| | BVC d:8 | 2 | | | | | |
| | BVS d:8 | 2 | | | | | |
| | BPL d:8 | 2 | | | | | |
| | BMI d:8 | 2 | | | | | |
| | BGE d:8 | 2 | | | | | |

| Instruction | Mnemonic | Instruction | Branch | Stack | Byte Data | Word Data | Internal |
|-------------|--------------------|-------------|------------|-----------|-----------|-----------|-----------|
| | | Fetch | Addr. Read | Operation | Access | Access | Operation |
| | | I | J | K | L | M | N |
| Bcc | BLT d:8 | 2 | | | | | |
| | BGT d:8 | 2 | | | | | |
| | BLE d:8 | 2 | | | | | |
| | BRA d:16(BT d:16) | 2 | | | | | 2 |
| | BRN d:16(BF d:16) | 2 | | | | | 2 |
| | BHI d:16 | 2 | | | | | 2 |
| | BLS d:16 | 2 | | | | | 2 |
| | BCC d:16(BHS d:16) | 2 | | | | | 2 |
| | BCS d:16(BLO d:16) | 2 | | | | | 2 |
| | BNE d:16 | 2 | | | | | 2 |
| | BEQ d:16 | 2 | | | | | 2 |
| | BVC d:16 | 2 | | | | | 2 |
| | BVS d:16 | 2 | | | | | 2 |
| | BPL d:16 | 2 | | | | | 2 |
| | BMI d:16 | 2 | | | | | 2 |
| | BGE d:16 | 2 | | | | | 2 |
| | BLT d:16 | 2 | | | | | 2 |
| | BGT d:16 | 2 | | | | | 2 |
| BLE d:16 | 2 | | | | | 2 | |
| BCLR | BCLR #xx:3, Rd | 1 | | | | | |
| | BCLR #xx:3, @ERd | 2 | | | 2 | | |
| | BCLR #xx:3, @aa:8 | 2 | | | 2 | | |
| | BCLR Rn, Rd | 1 | | | | | |
| | BCLR Rn, @ERd | 2 | | | 2 | | |
| | BCLR Rn, @aa:8 | 2 | | | 2 | | |
| BIAND | BIAND #xx:3, Rd | 1 | | | | | |
| | BIAND #xx:3, @ERd | 2 | | | 1 | | |
| | BIAND #xx:3, @aa:8 | 2 | | | 1 | | |
| BILD | BILD #xx:3, Rd | 1 | | | | | |
| | BILD #xx:3, @ERd | 2 | | | 1 | | |
| | BILD #xx:3, @aa:8 | 2 | | | 1 | | |

| Instruction | Mnemonic | Instruction | Branch | Stack | Byte Data | Word Data | Internal |
|-------------|--------------------|-------------|------------|-----------|-----------|-----------|-----------|
| | | Fetch | Addr. Read | Operation | Access | Access | Operation |
| | | I | J | K | L | M | N |
| BIOR | BIOR #xx:8, Rd | 1 | | | | | |
| | BIOR #xx:8, @ERd | 2 | | | 1 | | |
| | BIOR #xx:8, @aa:8 | 2 | | | 1 | | |
| BIST | BIST #xx:3, Rd | 1 | | | | | |
| | BIST #xx:3, @ERd | 2 | | | 2 | | |
| | BIST #xx:3, @aa:8 | 2 | | | 2 | | |
| BIXOR | BIXOR #xx:3, Rd | 1 | | | | | |
| | BIXOR #xx:3, @ERd | 2 | | | 1 | | |
| | BIXOR #xx:3, @aa:8 | 2 | | | 1 | | |
| BLD | BLD #xx:3, Rd | 1 | | | | | |
| | BLD #xx:3, @ERd | 2 | | | 1 | | |
| | BLD #xx:3, @aa:8 | 2 | | | 1 | | |
| BNOT | BNOT #xx:3, Rd | 1 | | | | | |
| | BNOT #xx:3, @ERd | 2 | | | 2 | | |
| | BNOT #xx:3, @aa:8 | 2 | | | 2 | | |
| | BNOT Rn, Rd | 1 | | | | | |
| | BNOT Rn, @ERd | 2 | | | 2 | | |
| | BNOT Rn, @aa:8 | 2 | | | 2 | | |
| BOR | BOR #xx:3, Rd | 1 | | | | | |
| | BOR #xx:3, @ERd | 2 | | | 1 | | |
| | BOR #xx:3, @aa:8 | 2 | | | 1 | | |
| BSET | BSET #xx:3, Rd | 1 | | | | | |
| | BSET #xx:3, @ERd | 2 | | | 2 | | |
| | BSET #xx:3, @aa:8 | 2 | | | 2 | | |
| | BSET Rn, Rd | 1 | | | | | |
| | BSET Rn, @ERd | 2 | | | 2 | | |
| | BSET Rn, @aa:8 | 2 | | | 2 | | |
| BSR | BSR d:8 | 2 | | 1 | | | |
| | BSR d:16 | 2 | | 1 | | | 2 |
| BST | BST #xx:3, Rd | 1 | | | | | |
| | BST #xx:3, @ERd | 2 | | | 2 | | |
| | BST #xx:3, @aa:8 | 2 | | | 2 | | |

| Instruction | Mnemonic | Instruction | Branch | Stack | Byte Data | Word Data | Internal |
|-------------|-------------------|-------------|------------|-----------|-------------|-----------|-----------|
| | | Fetch | Addr. Read | Operation | Access | Access | Operation |
| | | I | J | K | L | M | N |
| BTST | BTST #xx:3, Rd | 1 | | | | | |
| | BTST #xx:3, @ERd | 2 | | | 1 | | |
| | BTST #xx:3, @aa:8 | 2 | | | 1 | | |
| | BTST Rn, Rd | 1 | | | | | |
| | BTST Rn, @ERd | 2 | | | 1 | | |
| | BTST Rn, @aa:8 | 2 | | | 1 | | |
| BXOR | BXOR #xx:3, Rd | 1 | | | | | |
| | BXOR #xx:3, @ERd | 2 | | | 1 | | |
| | BXOR #xx:3, @aa:8 | 2 | | | 1 | | |
| CMP | CMP.B #xx:8, Rd | 1 | | | | | |
| | CMP.B Rs, Rd | 1 | | | | | |
| | CMP.W #xx:16, Rd | 2 | | | | | |
| | CMP.W Rs, Rd | 1 | | | | | |
| | CMP.L #xx:32, ERd | 3 | | | | | |
| | CMP.L ERs, ERd | 1 | | | | | |
| DAA | DAA Rd | 1 | | | | | |
| DAS | DAS Rd | 1 | | | | | |
| DEC | DEC.B Rd | 1 | | | | | |
| | DEC.W #1/2, Rd | 1 | | | | | |
| | DEC.L #1/2, ERd | 1 | | | | | |
| DIVXS | DIVXS.B Rs, Rd | 2 | | | | | 12 |
| | DIVXS.W Rs, ERd | 2 | | | | | 20 |
| DIVXU | DIVXU.B Rs, Rd | 1 | | | | | 12 |
| | DIVXU.W Rs, ERd | 1 | | | | | 20 |
| EEPMOV | EEPMOV.B | 2 | | | $2n+2^{*1}$ | | |
| | EEPMOV.W | 2 | | | $2n+2^{*1}$ | | |
| EXTS | EXTS.W Rd | 1 | | | | | |
| | EXTS.L ERd | 1 | | | | | |
| EXTU | EXTU.W Rd | 1 | | | | | |
| | EXTU.L ERd | 1 | | | | | |

| Instruction | Mnemonic | Instruction | Branch | Stack | Byte Data | Word Data | Internal |
|-------------|------------------------|-------------|------------|-----------|-----------|-----------|-----------|
| | | Fetch | Addr. Read | Operation | Access | Access | Operation |
| | | I | J | K | L | M | N |
| INC | INC.B Rd | 1 | | | | | |
| | INC.W #1/2, Rd | 1 | | | | | |
| | INC.L #1/2, ERd | 1 | | | | | |
| JMP | JMP @ERn | 2 | | | | | |
| | JMP @aa:24 | 2 | | | | | 2 |
| | JMP @@aa:8 | 2 | 1 | | | | 2 |
| JSR | JSR @ERn | 2 | | 1 | | | |
| | JSR @aa:24 | 2 | | 1 | | | 2 |
| | JSR @@aa:8 | 2 | 1 | 1 | | | |
| LDC | LDC #xx:8, CCR | 1 | | | | | |
| | LDC Rs, CCR | 1 | | | | | |
| | LDC@ERs, CCR | 2 | | | | 1 | |
| | LDC@(d:16, ERs), CCR | 3 | | | | 1 | |
| | LDC@(d:24, ERs), CCR | 5 | | | | 1 | |
| | LDC@ERs+, CCR | 2 | | | | 1 | 2 |
| | LDC@aa:16, CCR | 3 | | | | 1 | |
| | LDC@aa:24, CCR | 4 | | | | 1 | |
| MOV | MOV.B #xx:8, Rd | 1 | | | | | |
| | MOV.B Rs, Rd | 1 | | | | | |
| | MOV.B @ERs, Rd | 1 | | | 1 | | |
| | MOV.B @(d:16, ERs), Rd | 2 | | | 1 | | |
| | MOV.B @(d:24, ERs), Rd | 4 | | | 1 | | |
| | MOV.B @ERs+, Rd | 1 | | | 1 | | 2 |
| | MOV.B @aa:8, Rd | 1 | | | 1 | | |
| | MOV.B @aa:16, Rd | 2 | | | 1 | | |
| | MOV.B @aa:24, Rd | 3 | | | 1 | | |
| | MOV.B Rs, @Erd | 1 | | | 1 | | |
| | MOV.B Rs, @(d:16, ERd) | 2 | | | 1 | | |
| | MOV.B Rs, @(d:24, ERd) | 4 | | | 1 | | |
| | MOV.B Rs, @-ERd | 1 | | | 1 | | 2 |
| | MOV.B Rs, @aa:8 | 1 | | | 1 | | |

| Instruction | Mnemonic | Instruction | Branch | Stack | Byte Data | Word Data | Internal |
|-----------------------|------------------------|-------------|------------|-----------|-----------|-----------|-----------|
| | | Fetch | Addr. Read | Operation | Access | Access | Operation |
| | | I | J | K | L | M | N |
| MOV | MOV.B Rs, @aa:16 | 2 | | | 1 | | |
| | MOV.B Rs, @aa:24 | 3 | | | 1 | | |
| | MOV.W #xx:16, Rd | 2 | | | | | |
| | MOV.W Rs, Rd | 1 | | | | | |
| | MOV.W @ERs, Rd | 1 | | | | 1 | |
| | MOV.W @(d:16,ERs), Rd | 2 | | | | 1 | |
| | MOV.W @(d:24,ERs), Rd | 4 | | | | 1 | |
| | MOV.W @ERs+, Rd | 1 | | | | 1 | 2 |
| | MOV.W @aa:16, Rd | 2 | | | | 1 | |
| | MOV.W @aa:24, Rd | 3 | | | | 1 | |
| | MOV.W Rs, @ERd | 1 | | | | 1 | |
| | MOV.W Rs, @(d:16,ERd) | 2 | | | | 1 | |
| MOV.W Rs, @(d:24,ERd) | 4 | | | | 1 | | |
| MOV | MOV.W Rs, @-ERd | 1 | | | | 1 | 2 |
| | MOV.W Rs, @aa:16 | 2 | | | | 1 | |
| | MOV.W Rs, @aa:24 | 3 | | | | 1 | |
| | MOV.L #xx:32, ERd | 3 | | | | | |
| | MOV.L ERs, ERd | 1 | | | | | |
| | MOV.L @ERs, ERd | 2 | | | | 2 | |
| | MOV.L @(d:16,ERs), ERd | 3 | | | | 2 | |
| | MOV.L @(d:24,ERs), ERd | 5 | | | | 2 | |
| | MOV.L @ERs+, ERd | 2 | | | | 2 | 2 |
| | MOV.L @aa:16, ERd | 3 | | | | 2 | |
| | MOV.L @aa:24, ERd | 4 | | | | 2 | |
| | MOV.L ERs, @ERd | 2 | | | | 2 | |
| | MOV.L ERs, @(d:16,ERd) | 3 | | | | 2 | |
| | MOV.L ERs, @(d:24,ERd) | 5 | | | | 2 | |
| | MOV.L ERs, @-ERd | 2 | | | | 2 | 2 |
| | MOV.L ERs, @aa:16 | 3 | | | | 2 | |
| MOV.L ERs, @aa:24 | 4 | | | | 2 | | |
| MOVFP | MOVFP @aa:16, Rd*2 | 2 | | | 1 | | |
| MOVTP | MOVTP Rs, @aa:16*2 | 2 | | | 1 | | |

| Instruction | Mnemonic | Instruction | Branch | Stack | Byte Data | Word Data | Internal |
|-------------|------------------|-------------|------------|-----------|-----------|-----------|-----------|
| | | Fetch | Addr. Read | Operation | Access | Access | Operation |
| | | I | J | K | L | M | N |
| MULXS | MULXS.B Rs, Rd | 2 | | | | | 12 |
| | MULXS.W Rs, ERd | 2 | | | | | 20 |
| MULXU | MULXU.B Rs, Rd | 1 | | | | | 12 |
| | MULXU.W Rs, ERd | 1 | | | | | 20 |
| NEG | NEG.B Rd | 1 | | | | | |
| | NEG.W Rd | 1 | | | | | |
| | NEG.L ERd | 1 | | | | | |
| NOP | NOP | 1 | | | | | |
| NOT | NOT.B Rd | 1 | | | | | |
| | NOT.W Rd | 1 | | | | | |
| | NOT.L ERd | 1 | | | | | |
| OR | OR.B #xx:8, Rd | 1 | | | | | |
| | OR.B Rs, Rd | 1 | | | | | |
| | OR.W #xx:16, Rd | 2 | | | | | |
| | OR.W Rs, Rd | 1 | | | | | |
| | OR.L #xx:32, ERd | 3 | | | | | |
| | OR.L ERs, ERd | 2 | | | | | |
| ORC | ORC #xx:8, CCR | 1 | | | | | |
| POP | POP.W Rn | 1 | | | | 1 | 2 |
| | POP.L ERn | 2 | | | | 2 | 2 |
| PUSH | PUSH.W Rn | 1 | | | | 1 | 2 |
| | PUSH.L ERn | 2 | | | | 2 | 2 |
| ROTL | ROTL.B Rd | 1 | | | | | |
| | ROTL.W Rd | 1 | | | | | |
| | ROTL.L ERd | 1 | | | | | |
| ROTR | ROTR.B Rd | 1 | | | | | |
| | ROTR.W Rd | 1 | | | | | |
| | ROTR.L ERd | 1 | | | | | |
| ROTXL | ROTXL.B Rd | 1 | | | | | |
| | ROTXL.W Rd | 1 | | | | | |
| | ROTXL.L ERd | 1 | | | | | |

| Instruction | Mnemonic | Instruction | Branch | Stack | Byte Data | Word Data | Internal |
|-------------|----------------------|-------------|------------|-----------|-----------|-----------|-----------|
| | | Fetch | Addr. Read | Operation | Access | Access | Operation |
| | | I | J | K | L | M | N |
| ROTXR | ROTXR.B Rd | 1 | | | | | |
| | ROTXR.W Rd | 1 | | | | | |
| | ROTXR.L ERd | 1 | | | | | |
| RTE | RTE | 2 | | 2 | | | 2 |
| RTS | RTS | 2 | | 1 | | | 2 |
| SHAL | SHAL.B Rd | 1 | | | | | |
| | SHAL.W Rd | 1 | | | | | |
| | SHAL.L ERd | 1 | | | | | |
| SHAR | SHAR.B Rd | 1 | | | | | |
| | SHAR.W Rd | 1 | | | | | |
| | SHAR.L ERd | 1 | | | | | |
| SHLL | SHLL.B Rd | 1 | | | | | |
| | SHLL.W Rd | 1 | | | | | |
| | SHLL.L ERd | 1 | | | | | |
| SHLR | SHLR.B Rd | 1 | | | | | |
| | SHLR.W Rd | 1 | | | | | |
| | SHLR.L ERd | 1 | | | | | |
| SLEEP | SLEEP | 1 | | | | | |
| STC | STC CCR, Rd | 1 | | | | | |
| | STC CCR, @ERd | 2 | | | | 1 | |
| | STC CCR, @(d:16,ERd) | 3 | | | | 1 | |
| | STC CCR, @(d:24,ERd) | 5 | | | | 1 | |
| | STC CCR, @-ERd | 2 | | | | 1 | 2 |
| | STC CCR, @aa:16 | 3 | | | | 1 | |
| | STC CCR, @aa:24 | 4 | | | | 1 | |
| SUB | SUB.B Rs, Rd | 1 | | | | | |
| | SUB.W #xx:16, Rd | 2 | | | | | |
| | SUB.W Rs, Rd | 1 | | | | | |
| | SUB.L #xx:32, ERd | 3 | | | | | |
| | SUB.L ERs, ERd | 1 | | | | | |
| SUBS | SUBS #1/2/4, ERd | 1 | | | | | |

| Instruction | Mnemonic | Instruction | Branch | Stack | Byte Data | Word Data | Internal |
|-------------|-------------------|-------------|------------|-----------|-----------|-----------|-----------|
| | | Fetch | Addr. Read | Operation | Access | Access | Operation |
| | | I | J | K | L | M | N |
| SUBX | SUBX #xx:8, Rd | 1 | | | | | |
| | SUBX. Rs, Rd | 1 | | | | | |
| TRAPA | TRAPA #xx:2 | 2 | 1 | 2 | | | 4 |
| XOR | XOR.B #xx:8, Rd | 1 | | | | | |
| | XOR.B Rs, Rd | 1 | | | | | |
| | XOR.W #xx:16, Rd | 2 | | | | | |
| | XOR.W Rs, Rd | 1 | | | | | |
| | XOR.L #xx:32, ERd | 3 | | | | | |
| | XOR.L ERs, ERd | 2 | | | | | |
| XORC | XORC #xx:8, CCR | 1 | | | | | |

- Notes:
1. n: Specified value in R4L. The source and destination operands are accessed n+1 times respectively.
 2. It can not be used in this LSI.

A.4 Combinations of Instructions and Addressing Modes

Table A.5 Combinations of Instructions and Addressing Modes

| Functions | Instructions | Addressing Mode | | | | | | | | | | | | |
|----------------------------------|----------------------------|-----------------|-----|------|-------------|-------------|------------|-------|--------|--------|-----------|------------|--------|----|
| | | #xx | Rn | @ERn | @(d:16.ERn) | @(d:24.ERn) | @ERn+/@ERn | @aa:8 | @aa:16 | @aa:24 | @(d:8.PC) | @(d:16.PC) | @@aa:8 | |
| Data transfer instructions | MOV | BWL | BWL | BWL | BWL | BWL | BWL | B | BWL | BWL | — | — | — | — |
| | POP, PUSH | — | — | — | — | — | — | — | — | — | — | — | — | WL |
| | MOVFP, MOVTPE | — | — | — | — | — | — | — | — | — | — | — | — | — |
| Arithmetic operations | ADD, CMP | BWL | BWL | — | — | — | — | — | — | — | — | — | — | — |
| | SUB | WL | BWL | — | — | — | — | — | — | — | — | — | — | — |
| | ADDX, SUBX | B | B | — | — | — | — | — | — | — | — | — | — | — |
| | ADDS, SUBS | — | L | — | — | — | — | — | — | — | — | — | — | — |
| | INC, DEC | — | BWL | — | — | — | — | — | — | — | — | — | — | — |
| | DAA, DAS | — | B | — | — | — | — | — | — | — | — | — | — | — |
| | MULXU, MULXS, DIVXU, DIVXS | — | BW | — | — | — | — | — | — | — | — | — | — | — |
| | NEG | — | BWL | — | — | — | — | — | — | — | — | — | — | — |
| | EXTU, EXTS | — | WL | — | — | — | — | — | — | — | — | — | — | — |
| Logical operations | AND, OR, XOR | — | BWL | — | — | — | — | — | — | — | — | — | — | — |
| | NOT | — | BWL | — | — | — | — | — | — | — | — | — | — | — |
| Shift operations | | — | BWL | — | — | — | — | — | — | — | — | — | — | — |
| Bit manipulations | | — | B | B | — | — | — | B | — | — | — | — | — | — |
| Branching instructions | BCC, BSR | — | — | — | — | — | — | — | — | — | — | — | — | — |
| | JMP, JSR | — | — | ○ | — | — | — | — | — | — | ○ | ○ | — | — |
| | RTS | — | — | — | — | — | — | — | — | ○ | — | — | ○ | — |
| System control instructions | TRAPA | — | — | — | — | — | — | — | — | — | — | — | — | ○ |
| | RTE | — | — | — | — | — | — | — | — | — | — | — | — | ○ |
| | SLEEP | — | — | — | — | — | — | — | — | — | — | — | — | ○ |
| | LDC | B | B | W | W | W | W | — | W | W | — | — | — | ○ |
| | STC | — | B | W | W | W | W | — | W | W | — | — | — | — |
| | ANDC, ORC, XORC | B | — | — | — | — | — | — | — | — | — | — | — | — |
| | NOP | — | — | — | — | — | — | — | — | — | — | — | — | ○ |
| Block data transfer instructions | | — | — | — | — | — | — | — | — | — | — | — | — | BW |

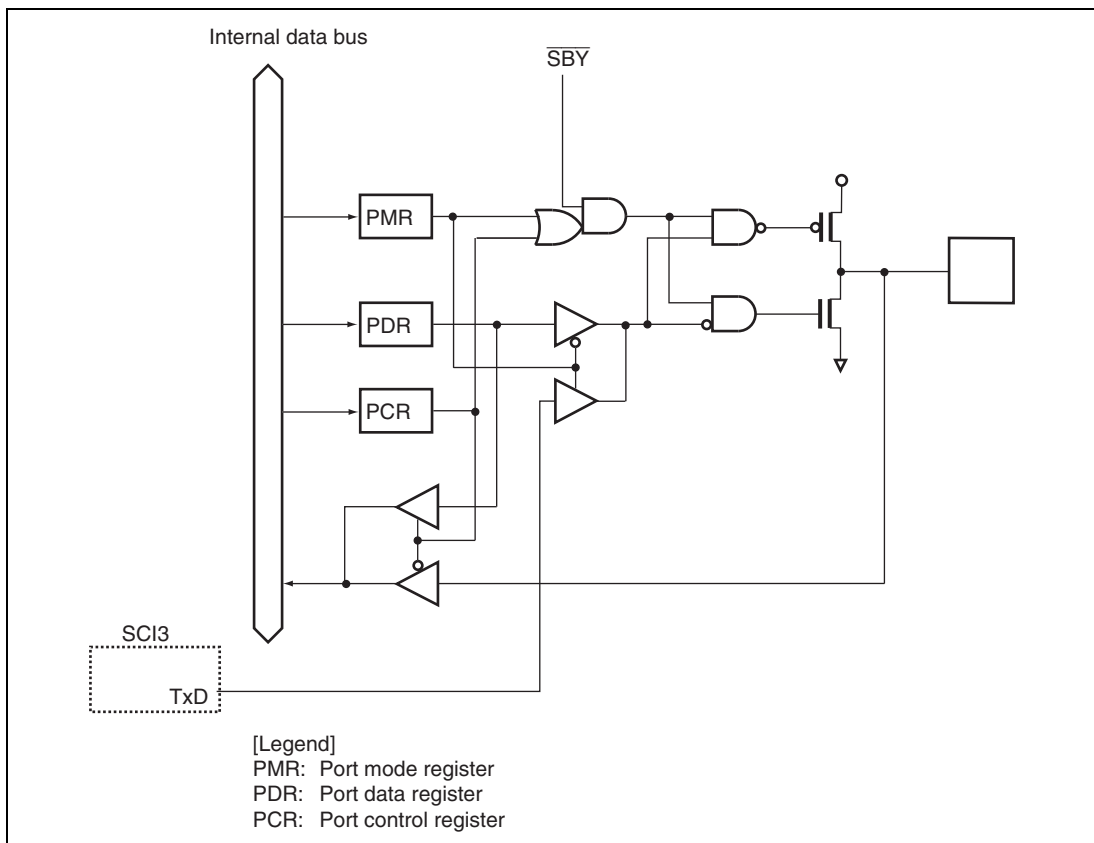

Figure B.5 Port 2 Block Diagram (P22)

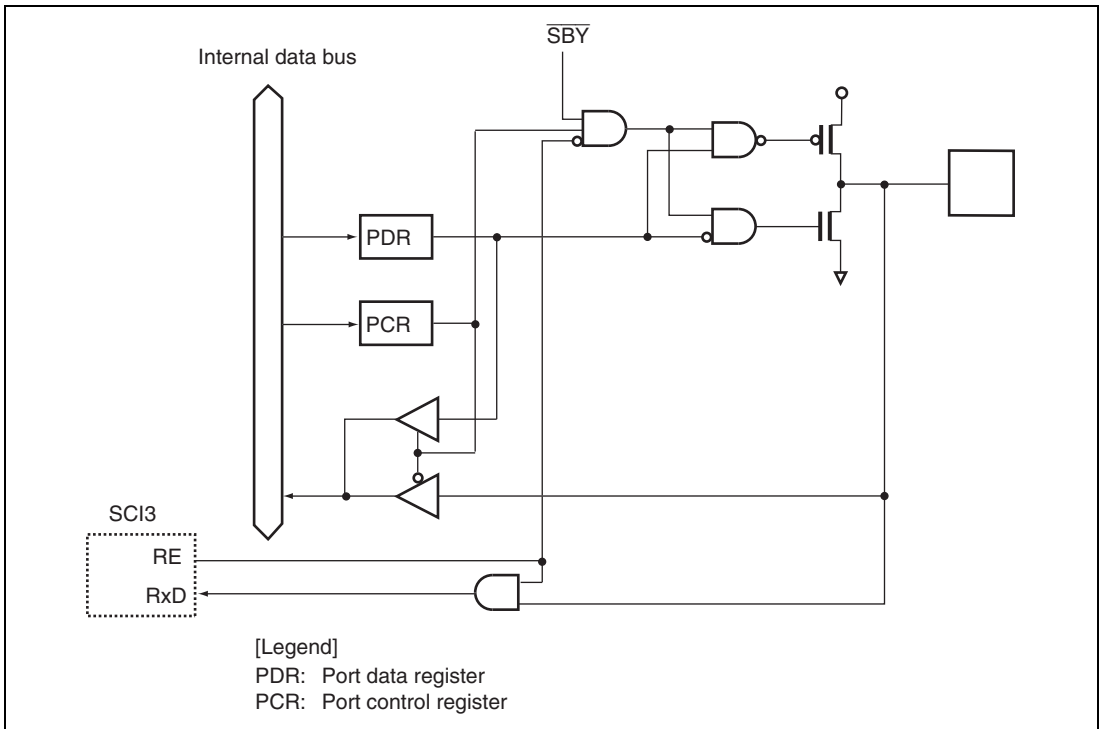

Figure B.6 Port 2 Block Diagram (P21)

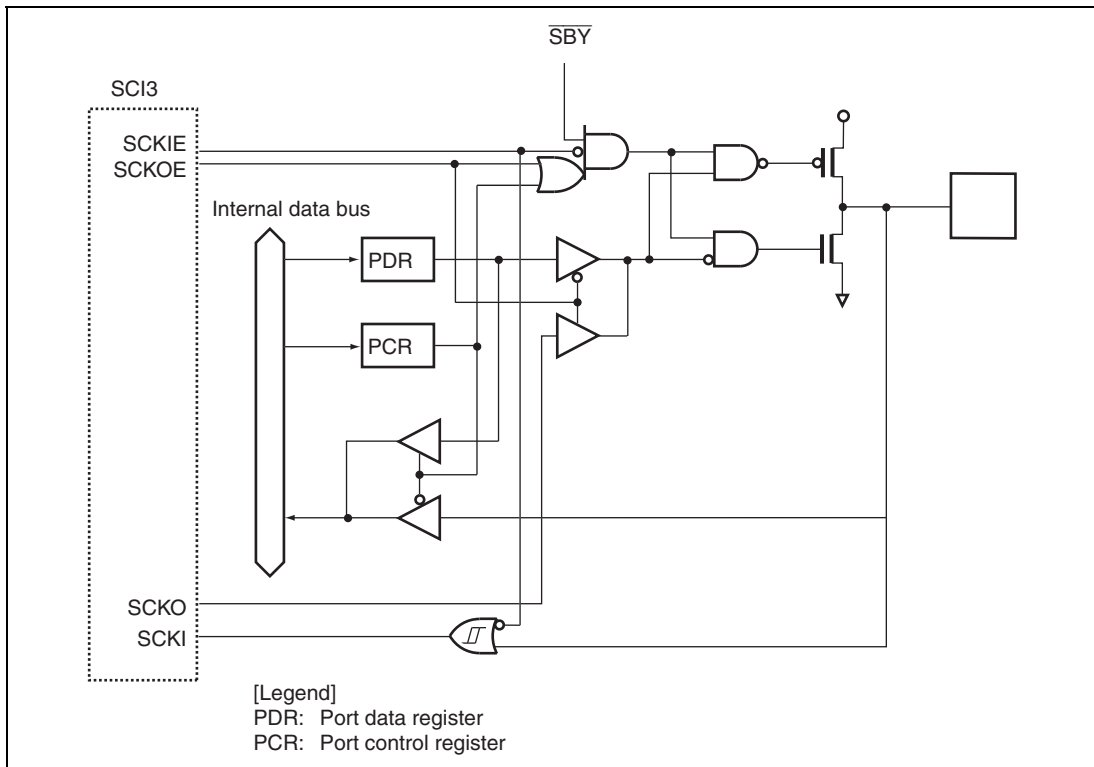

Figure B.7 Port 2 Block Diagram (P20)

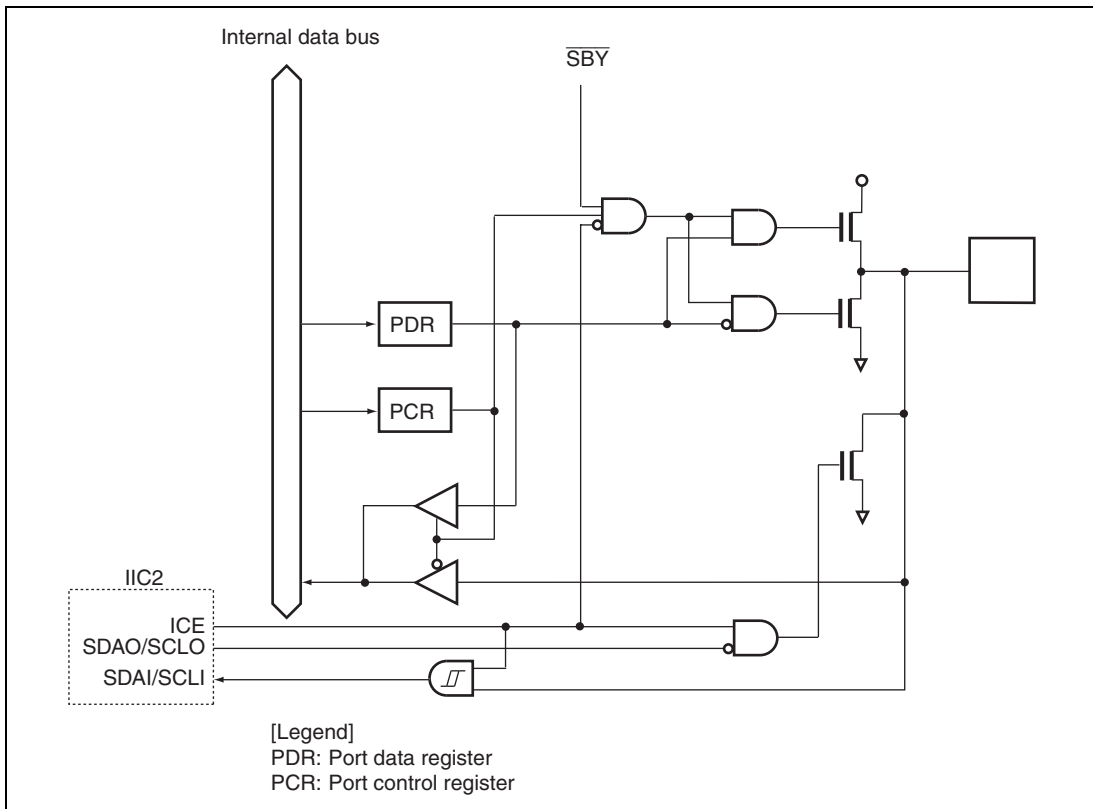

Figure B.8 Port 5 Block Diagram (P57, P56)*

Note: * This diagram is applied to the SCL and SDA pins in the H8/3694N.

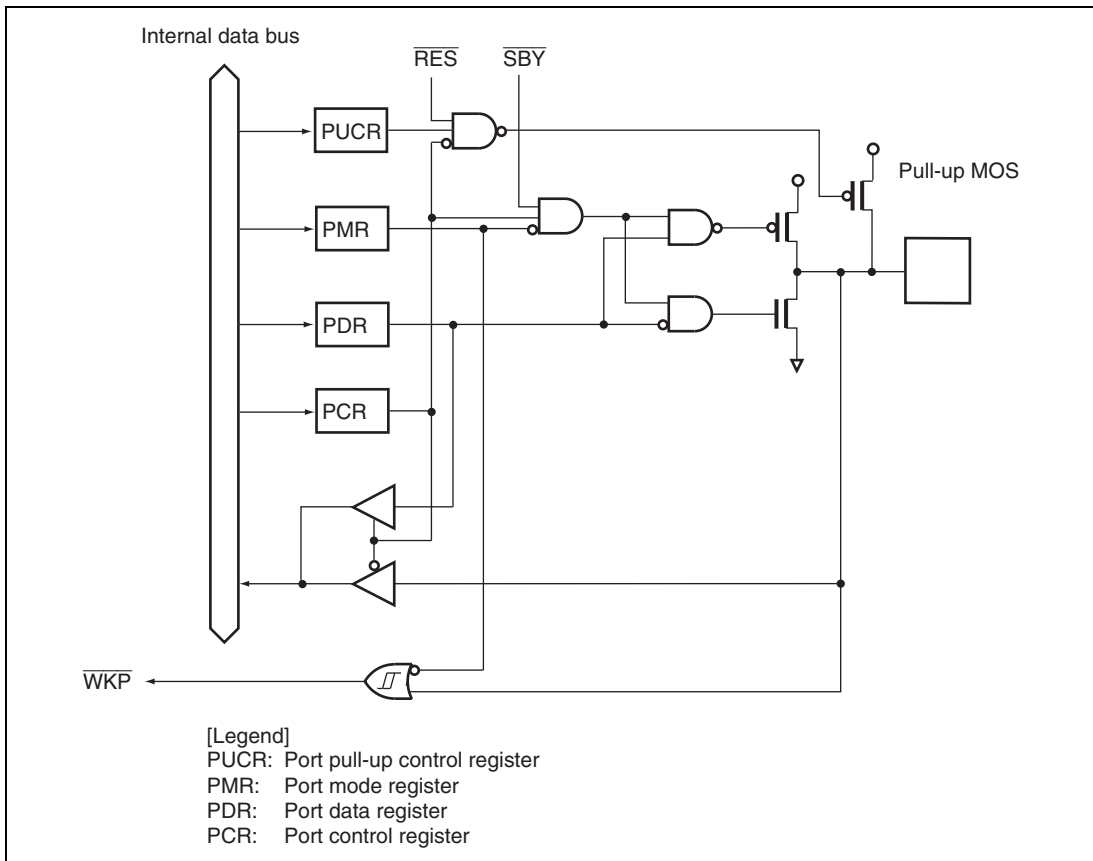

Figure B.10 Port 5 Block Diagram (P54 to P50)

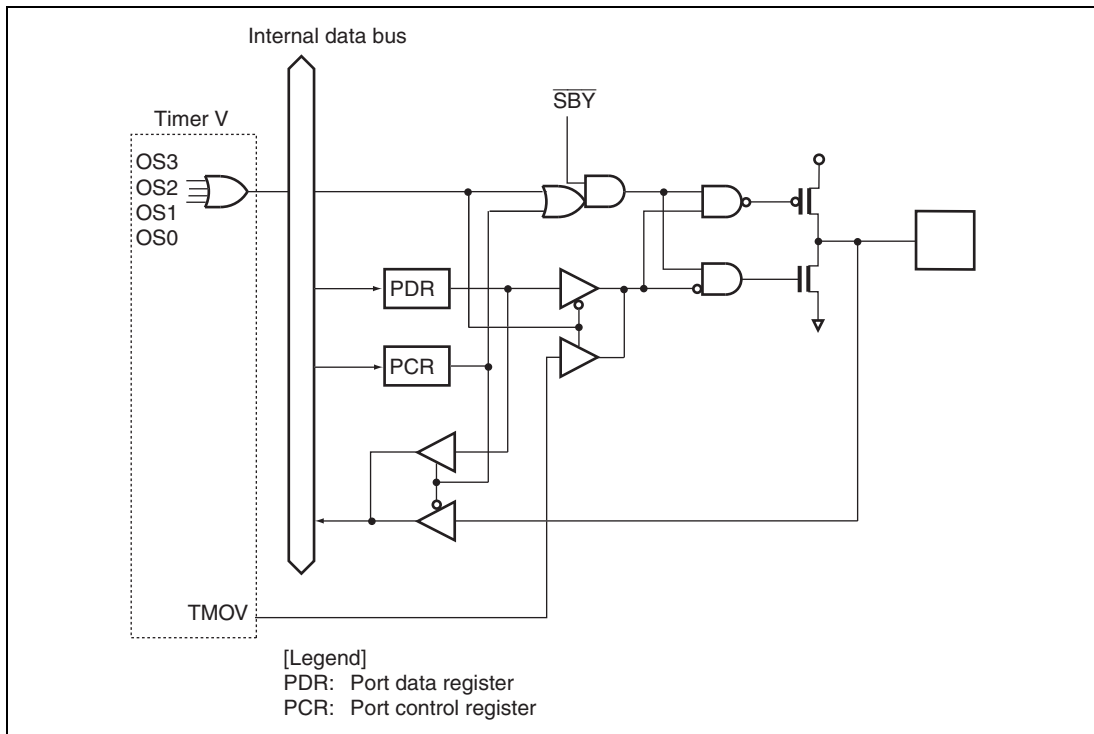

Figure B.11 Port 7 Block Diagram (P76)

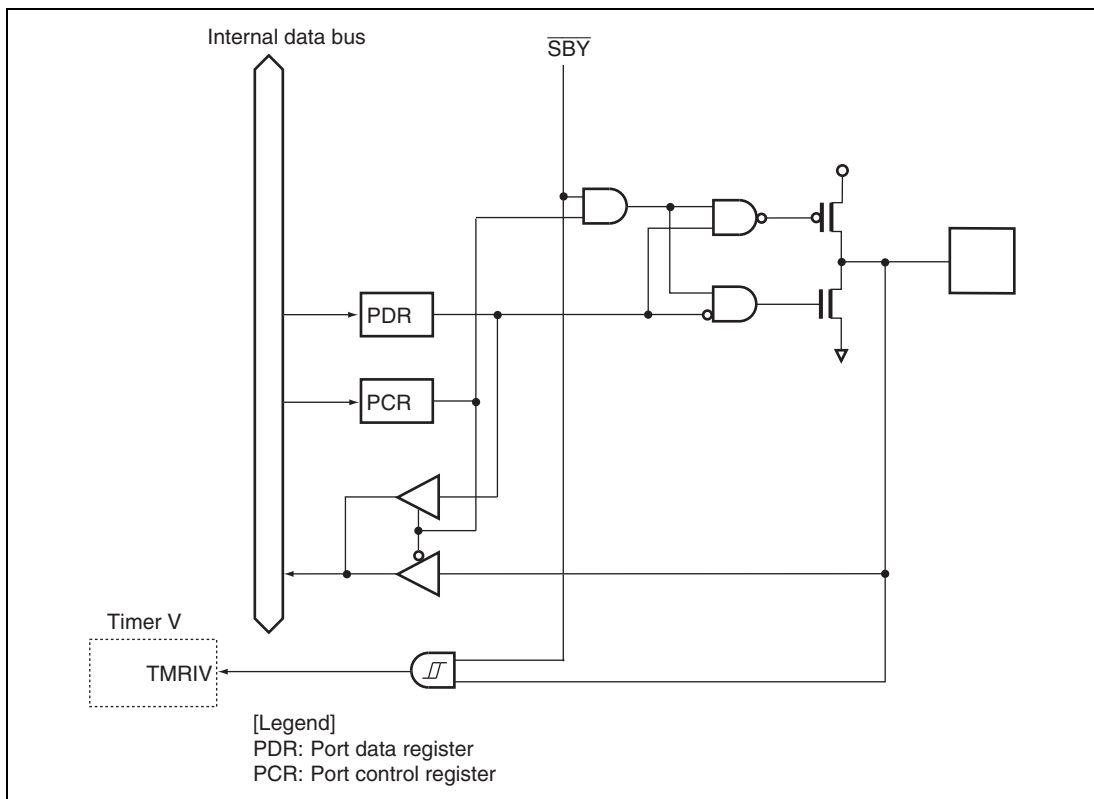

Figure B.13 Port 7 Block Diagram (P74)

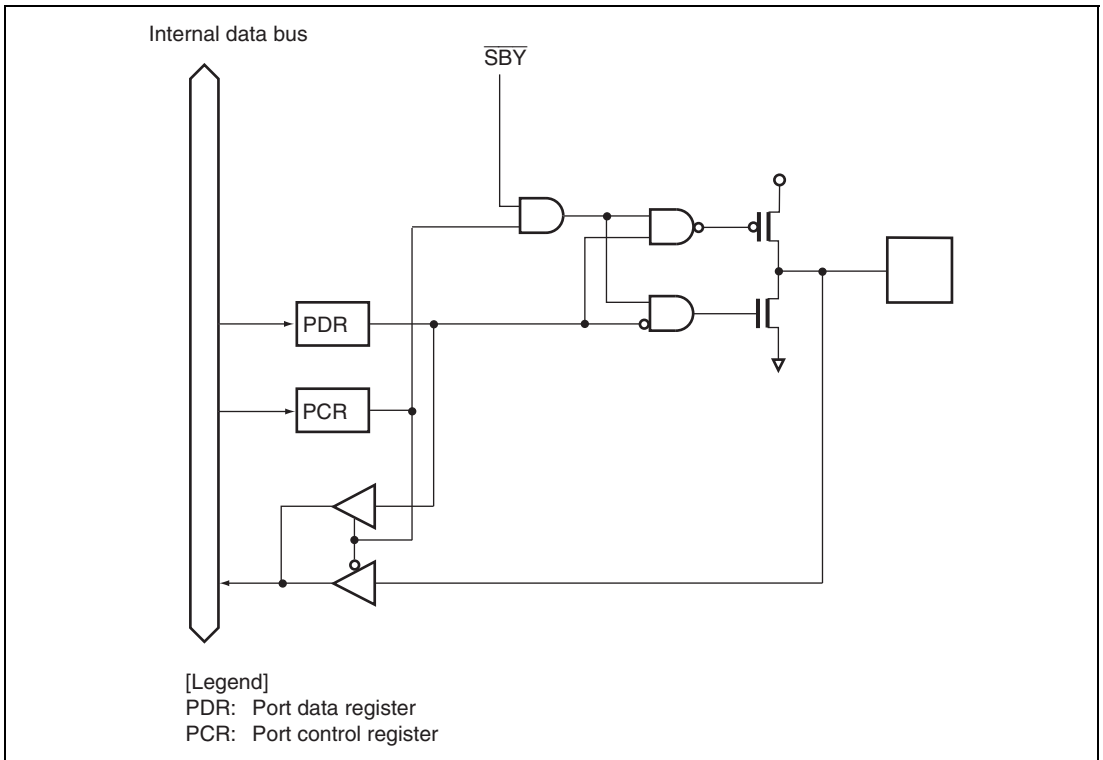

Figure B.14 Port 8 Block Diagram (P87 to P85)

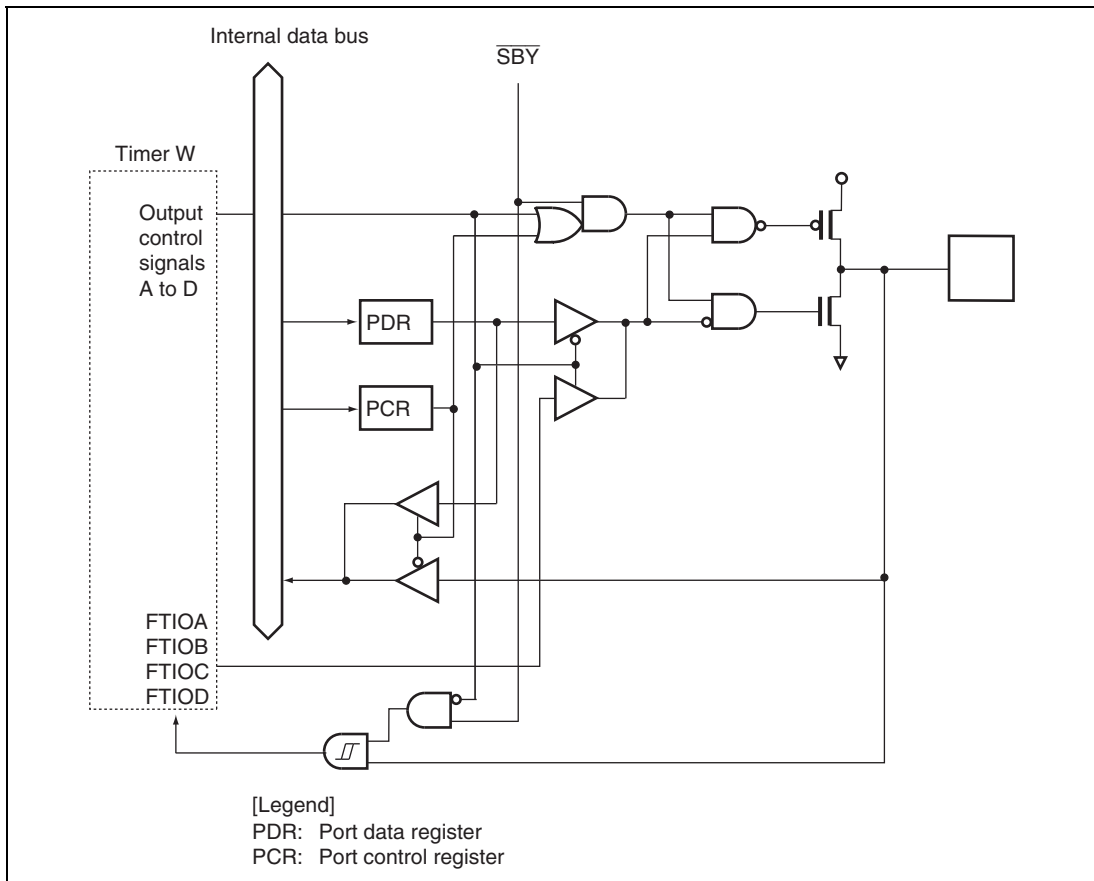

Figure B.15 Port 8 Block Diagram (P84 to P81)

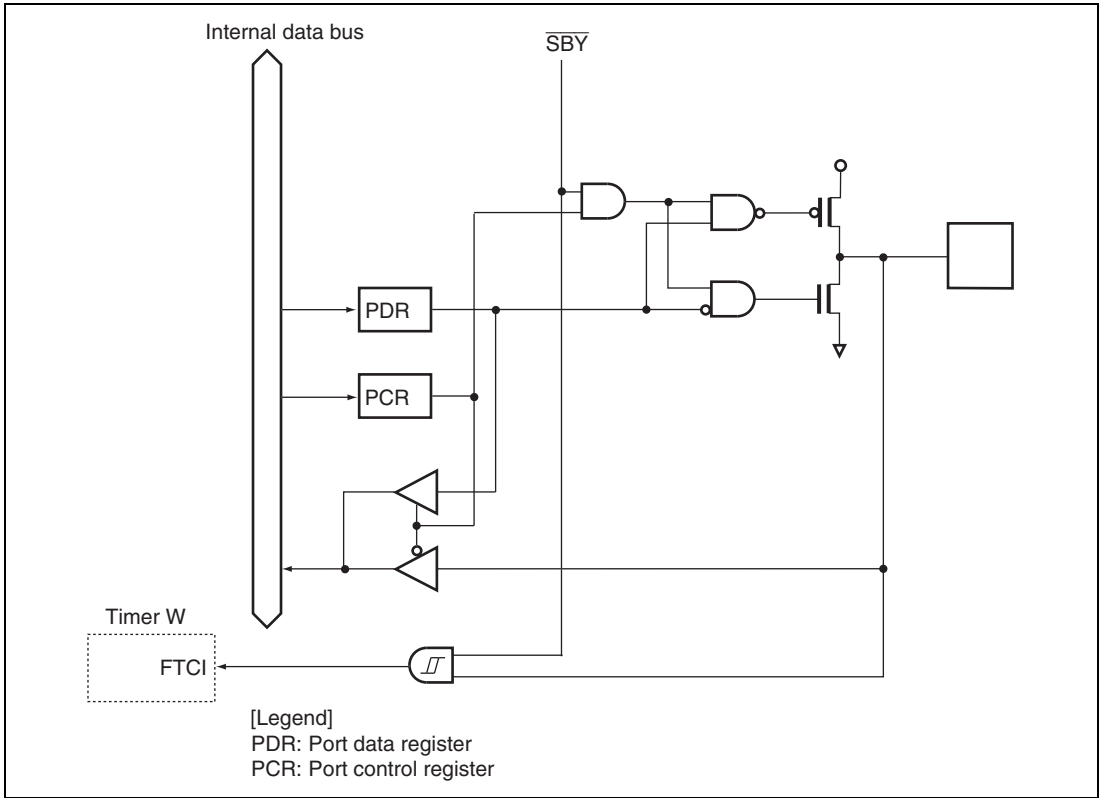

Figure B.16 Port 8 Block Diagram (P80)

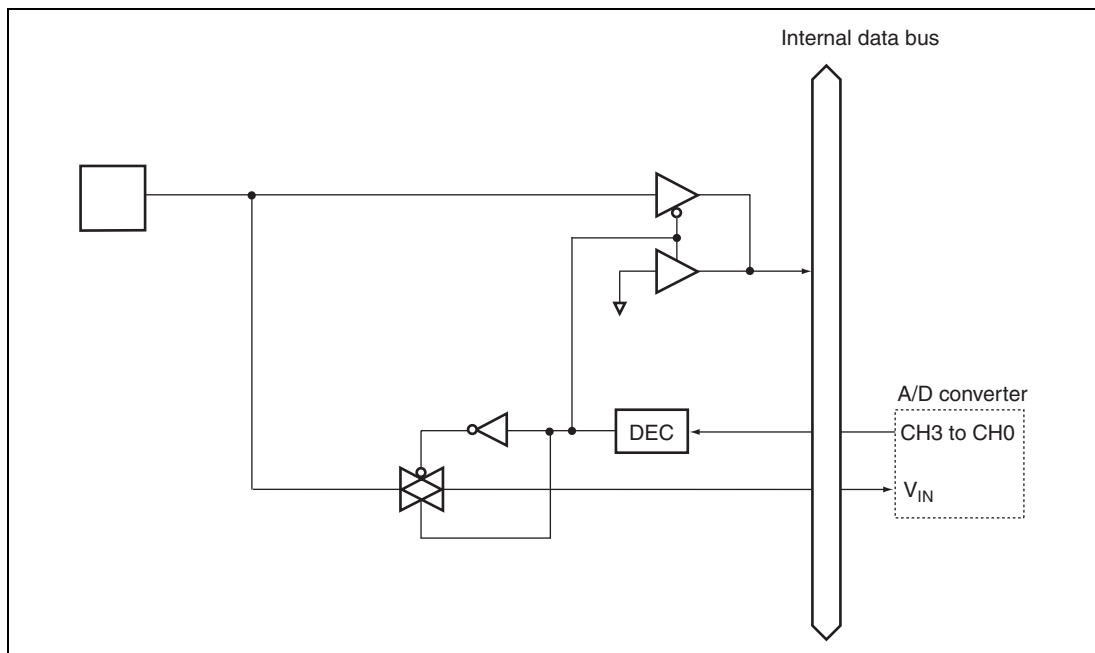

Figure B.17 Port B Block Diagram (PB7 to PB0)

B.2 Port States in Each Operating State

| Port | Reset | Sleep | Subsleep | Standby | Subactive | Active |
|---------------------------|----------------|----------------|----------------|------------------------------|----------------|----------------|
| P17 to P14, P12 to P10 | High impedance | Retained | Retained | High impedance* ¹ | Functioning | Functioning |
| P22 to P20 | High impedance | Retained | Retained | High impedance | Functioning | Functioning |
| P57 to P50* ² | High impedance | Retained | Retained | High impedance* ¹ | Functioning | Functioning |
| P76 to P74 | High impedance | Retained | Retained | High impedance | Functioning | Functioning |
| P87 to P80 | High impedance | Retained | Retained | High impedance | Functioning | Functioning |
| PB7 to PB0 | High impedance | High impedance | High impedance | High impedance | High impedance | High impedance |

Notes: 1. High level output when the pull-up MOS is in on state.

2. The P55 to P50 pins are applied to the H8/3694N.

Appendix C Product Code Lineup

| Product Classification | | | Product Code | Model Marking | Package Code | |
|-------------------------|-------------------------|------------------|--------------|------------------|-------------------|------------------|
| H8/3694 | Flash memory version | Standard product | HD64F3694H | HD64F3694H | QFP-64 (FP-64A) | |
| | | | HD64F3694FP | HD64F3694FP | LQFP-64 (FP-64E) | |
| | | | HD64F3694FX | HD64F3694FX | LQFP-48 (FP-48F) | |
| | | | HD64F3694FY | HD64F3694FY | LQFP-48 (FP-48B) | |
| | | | HD64F3694FT | HD64F3694FT | QFN-48(TNP-48) | |
| | Product with POR & LVDC | | | HD64F3694GH | HD64F3694GH | QFP-64 (FP-64A) |
| | | | | HD64F3694GFP | HD64F3694GFP | LQFP-64 (FP-64E) |
| | | | | HD64F3694GFX | HD64F3694GFX | LQFP-48 (FP-48F) |
| | | | | HD64F3694GFY | HD64F3694GFY | LQFP-48 (FP-48B) |
| | | | | HD64F3694GFT | HD64F3694GFT | QFN-48(TNP-48) |
| | Mask ROM version | Standard product | | HD6433694H | HD6433694(***)H | QFP-64 (FP-64A) |
| | | | | HD6433694FP | HD6433694(***)FP | LQFP-64 (FP-64E) |
| | | | | HD6433694FX | HD6433694(***)FX | LQFP-48 (FP-48F) |
| | | | | HD6433694FY | HD6433694(***)FY | LQFP-48 (FP-48B) |
| HD6433694FT | | | | HD6433694(***)FT | QFN-48(TNP-48) | |
| Product with POR & LVDC | | | | HD6433694GH | HD6433694G(***)H | QFP-64 (FP-64A) |
| | | | | HD6433694GFP | HD6433694G(***)FP | LQFP-64 (FP-64E) |
| | | | | HD6433694GFX | HD6433694G(***)FX | LQFP-48 (FP-48F) |
| | | | | HD6433694GFY | HD6433694G(***)FY | LQFP-48 (FP-48B) |
| | | | | HD6433694GFT | HD6433694G(***)FT | QFN-48(TNP-48) |
| H8/3693 | Mask ROM version | Standard product | HD6433693H | HD6433693(***)H | QFP-64 (FP-64A) | |
| | | | HD6433693FP | HD6433693(***)FP | LQFP-64 (FP-64E) | |
| | | | HD6433693FX | HD6433693(***)FX | LQFP-48 (FP-48F) | |
| | | | HD6433693FY | HD6433693(***)FY | LQFP-48 (FP-48B) | |
| | | | HD6433693FT | HD6433693(***)FT | QFN-48(TNP-48) | |
| | Product with POR & LVDC | | | HD6433693GH | HD6433693G(***)H | QFP-64 (FP-64A) |
| | | | | HD6433693GFP | HD6433693G(***)FP | LQFP-64 (FP-64E) |
| | | | | HD6433693GFX | HD6433693G(***)FX | LQFP-48 (FP-48F) |
| | | | | HD6433693GFY | HD6433693G(***)FY | LQFP-48 (FP-48B) |
| | | | | HD6433693GFT | HD6433693G(***)FT | QFN-48(TNP-48) |

| Product Classification | | | Product Code | Model Marking | Package Code | |
|-------------------------|-------------------------|------------------|-------------------|------------------|------------------|------------------|
| H8/3692 | Mask ROM version | Standard product | HD6433692H | HD6433692(***)H | QFP-64 (FP-64A) | |
| | | | HD6433692FP | HD6433692(***)FP | LQFP-64 (FP-64E) | |
| | | | HD6433692FX | HD6433692(***)FX | LQFP-48 (FP-48F) | |
| | | | HD6433692FY | HD6433692(***)FY | LQFP-48 (FP-48B) | |
| | | | HD6433692FT | HD6433692(***)FT | QFN-48(TNP-48) | |
| | Product with POR & LVDC | HD6433692GH | HD6433692G(***)H | QFP-64 (FP-64A) | | |
| | | HD6433692GFP | HD6433692G(***)FP | LQFP-64 (FP-64E) | | |
| | | HD6433692GFX | HD6433692G(***)FX | LQFP-48 (FP-48F) | | |
| | | HD6433692GFY | HD6433692G(***)FY | LQFP-48 (FP-48B) | | |
| | | HD6433692GFT | HD6433692G(***)FT | QFN-48(TNP-48) | | |
| | H8/3691 | Mask ROM version | Standard product | HD6433691H | HD6433691(***)H | QFP-64 (FP-64A) |
| | | | | HD6433691FP | HD6433691(***)FP | LQFP-64 (FP-64E) |
| | | | | HD6433691FX | HD6433691(***)FX | LQFP-48 (FP-48F) |
| | | | | HD6433691FY | HD6433691(***)FY | LQFP-48 (FP-48B) |
| HD6433691FT | | | | HD6433691(***)FT | QFN-48(TNP-48) | |
| Product with POR & LVDC | | HD6433691GH | HD6433691G(***)H | QFP-64 (FP-64A) | | |
| | | HD6433691GFP | HD6433691G(***)FP | LQFP-64 (FP-64E) | | |
| | | HD6433691GFX | HD6433691G(***)FX | LQFP-48 (FP-48F) | | |
| | | HD6433691GFY | HD6433691G(***)FY | LQFP-48 (FP-48B) | | |
| | | HD6433691GFT | HD6433691G(***)FT | QFN-48(TNP-48) | | |
| H8/3690 | | Mask ROM version | Standard product | HD6433690H | HD6433690(***)H | QFP-64 (FP-64A) |
| | | | | HD6433690FP | HD6433690(***)FP | LQFP-64 (FP-64E) |
| | | | | HD6433690FX | HD6433690(***)FX | LQFP-48 (FP-48F) |
| | | | | HD6433690FY | HD6433690(***)FY | LQFP-48 (FP-48B) |
| | HD6433690FT | | | HD6433690(***)FT | QFN-48(TNP-48) | |
| | Product with POR & LVDC | HD6433690GH | HD6433690G(***)H | QFP-64 (FP-64A) | | |
| | | HD6433690GFP | HD6433690G(***)FP | LQFP-64 (FP-64E) | | |
| | | HD6433690GFX | HD6433690G(***)FX | LQFP-48 (FP-48F) | | |
| | | HD6433690GFY | HD6433690G(***)FY | LQFP-48 (FP-48B) | | |
| | | HD6433690GFT | HD6433690G(***)FT | QFN-48(TNP-48) | | |

| Product Classification | | Product Code | Model Marking | Package Code |
|--|---------------------------------------|---------------------|----------------------|---------------------|
| H8/3694N EEPROM Flash stacked memory version | Product with POR & LVDC version | HD64N3694GFP | HD64N3694GFP | LQFP-64 (FP-64E) |
| | Mask ROM version | HD6483694GFP | HD6483694G(***)FP | LQFP-64 (FP-64E) |

Legend:

(***): ROM code.

POR & LVDC: Power-on reset and low-voltage detection circuits.

Appendix D Package Dimensions

The package dimensions that are shown in the Renesas Semiconductor Packages Data Book have priority.

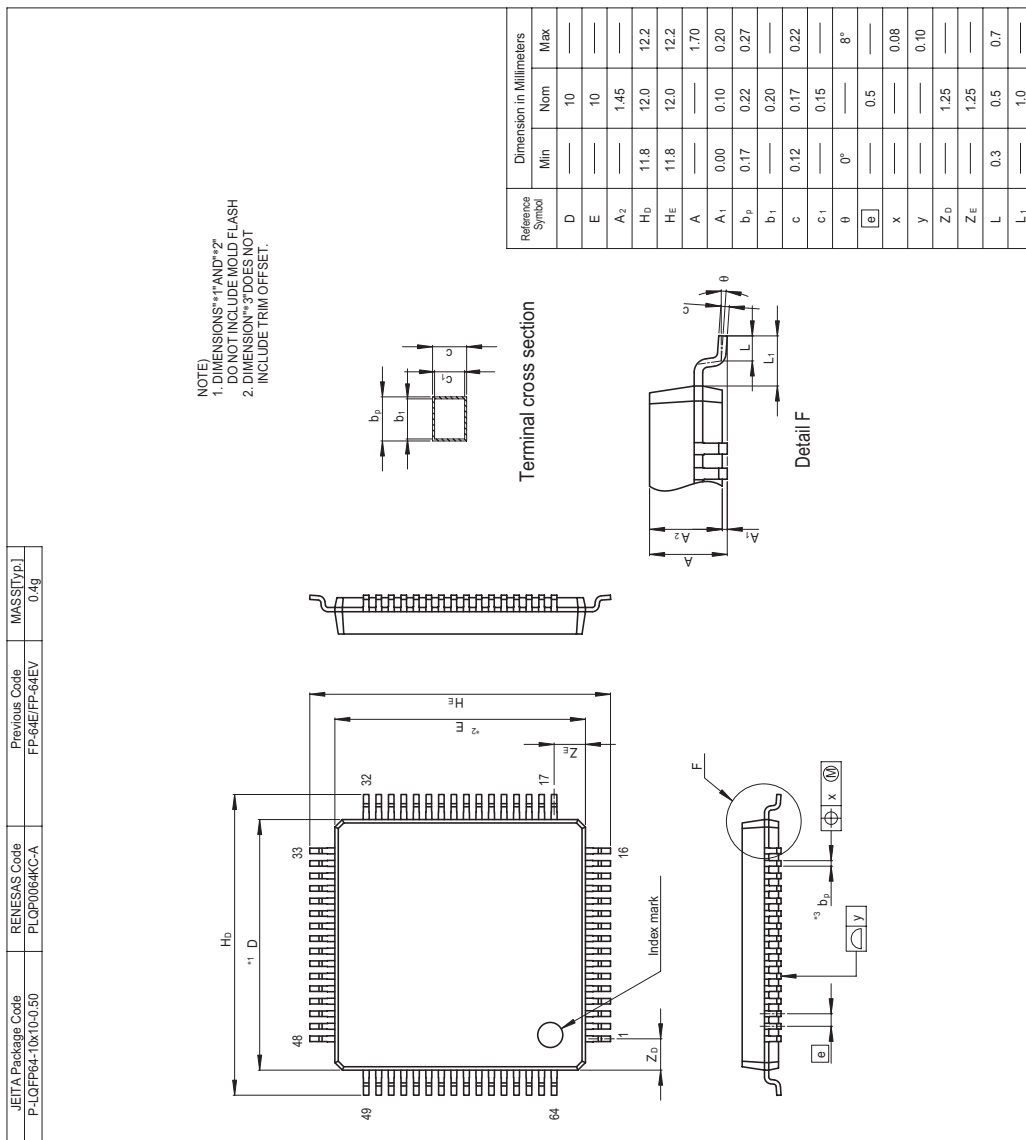

Figure D.1 FP-64E Package Dimensions

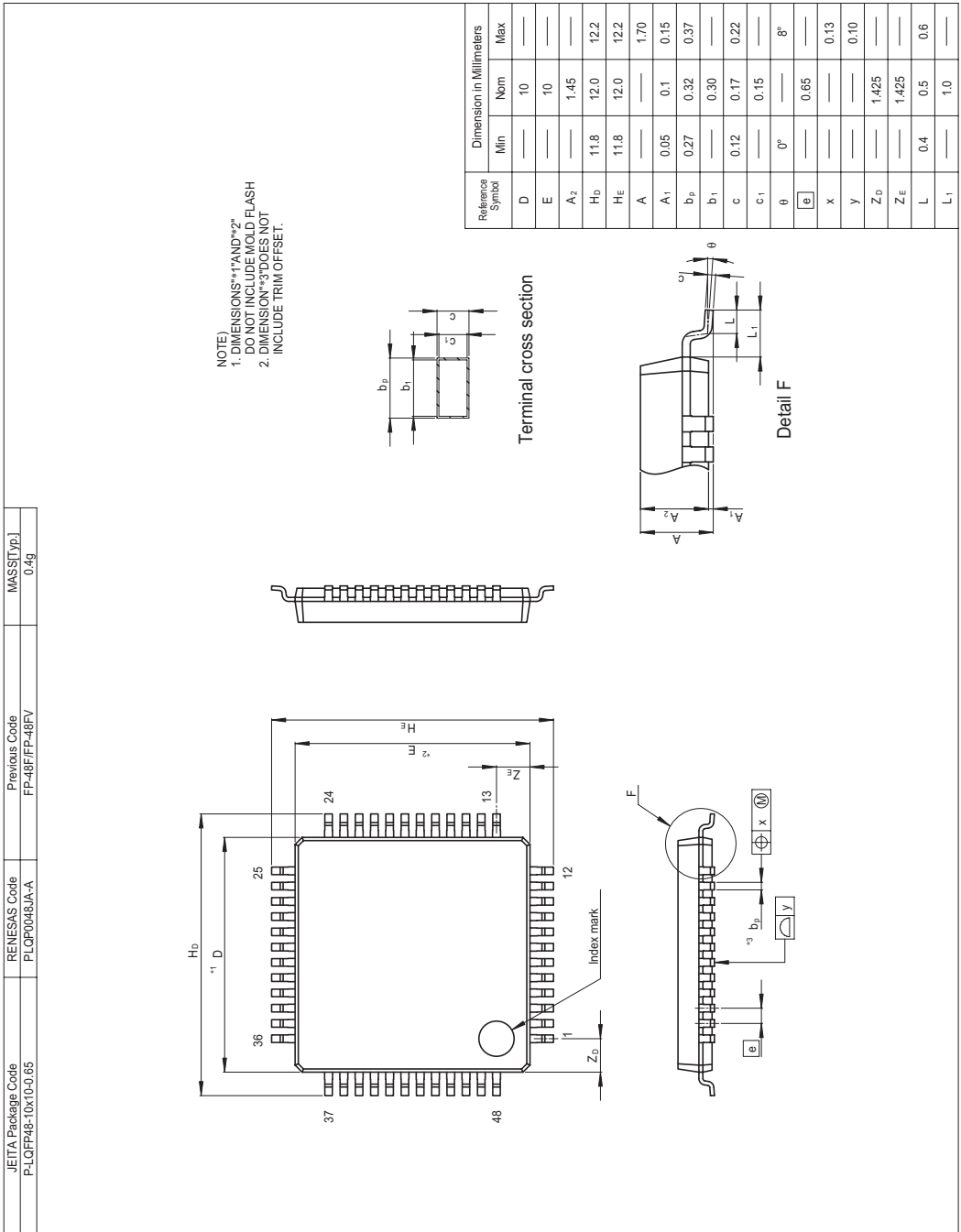

Figure D.3 FP-48F Package Dimensions

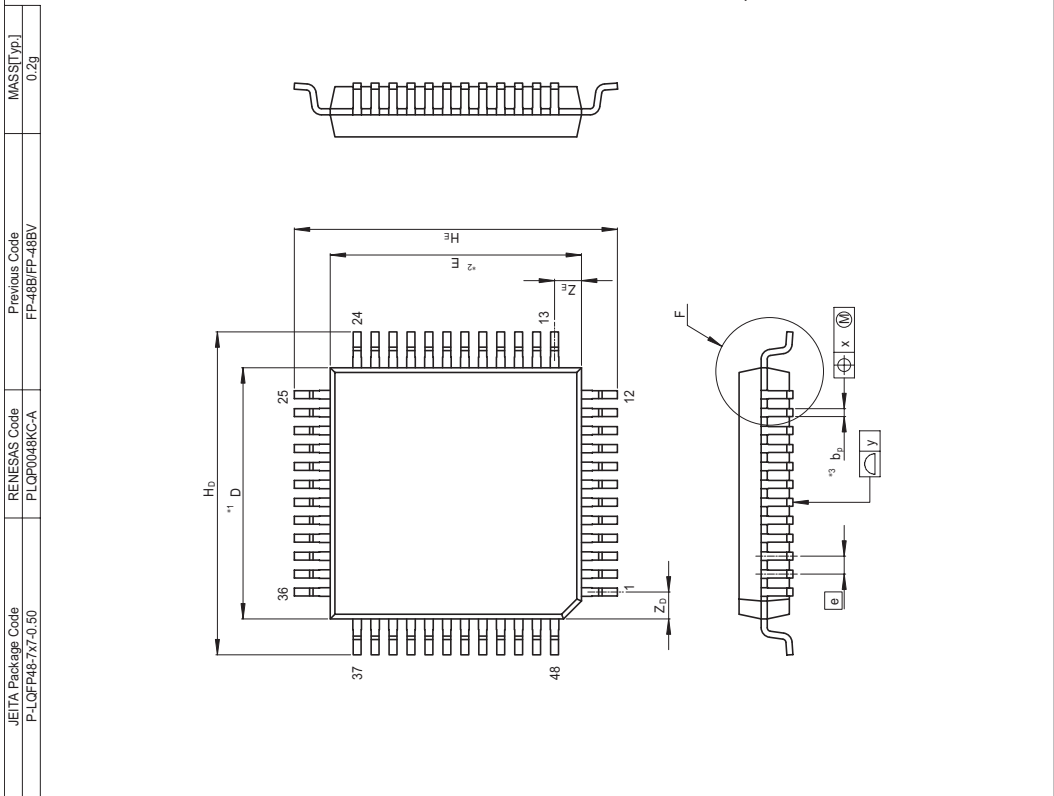
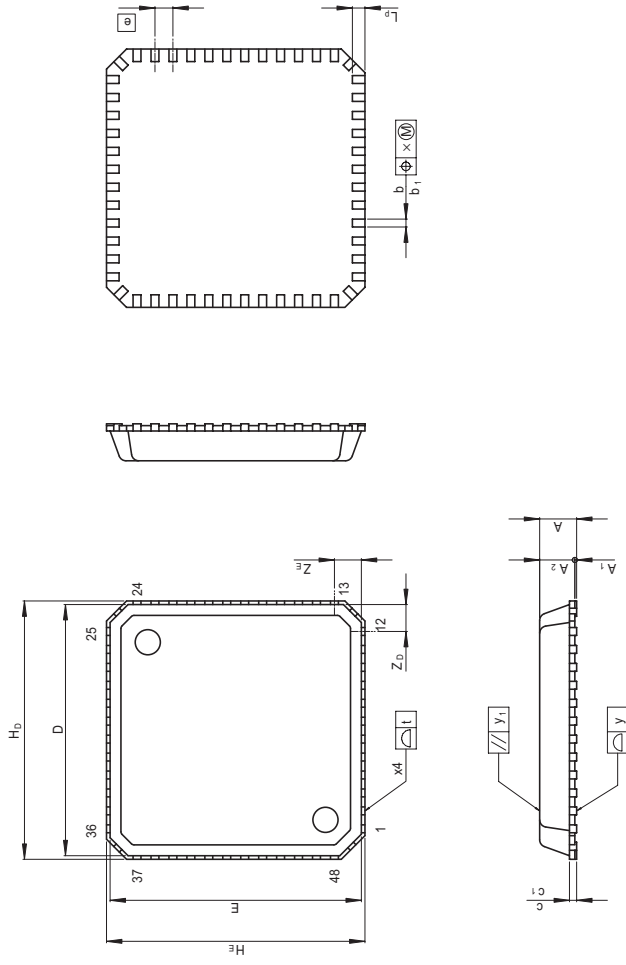

Figure D.4 FP-48B Package Dimensions

| | | | |
|---|-------------------------------|---------------------------------|---------------------|
| JEITA Package Code P-VQFN48-7x7-0.50 | RENESAS Code P1VQFN048KA-A | Previous Code TNP-48/TNP-48V | MASS [Typ.] 0.1g |
|---|-------------------------------|---------------------------------|---------------------|



| Reference Symbol | Dimension in Millimeters | | |
|------------------|--------------------------|------|------|
| | Mfn | Nom | Max |
| D | — | 7.0 | — |
| E | — | 7.0 | — |
| A ₂ | — | 0.90 | — |
| A | — | — | 1.00 |
| A ₁ | 0.005 | 0.02 | 0.04 |
| b | 0.17 | 0.22 | 0.27 |
| b ₁ | — | 0.20 | — |
| ϕ | — | 0.5 | — |
| L _P | 0.23 | 0.35 | 0.47 |
| x | — | — | 0.05 |
| y | — | — | 0.05 |
| y ₁ | — | — | 0.20 |
| t | — | — | 0.20 |
| H _D | — | 7.2 | — |
| H _E | — | 7.2 | — |
| Z _D | — | 0.75 | — |
| Z _E | — | 0.75 | — |
| c | 0.12 | 0.17 | 0.22 |
| c ₁ | — | 0.15 | — |

Figure D.5 TNP-48 Package Dimensions

Appendix E EEPROM Stacked-Structure Cross-Sectional View

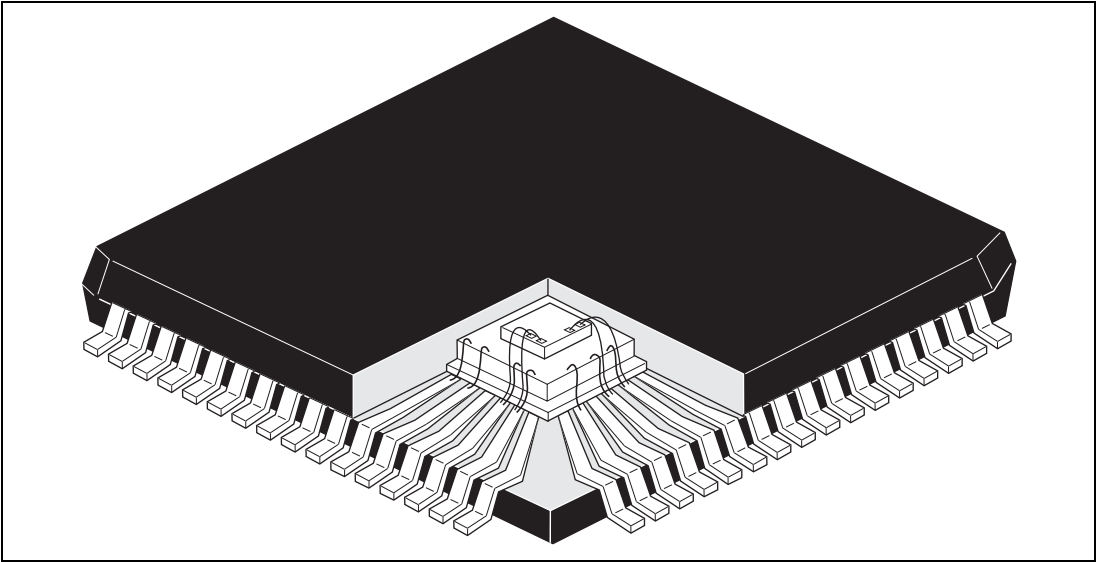

Figure E.1 EEPROM Stacked-Structure Cross-Sectional View

Main Revisions and Additions in this Edition

| Item | Page | Revision (See Manual for Details) |
|---------|---------|---|
| Preface | vi, vii | <p>Notes:</p> <p>When using the on-chip emulator (E7, E8) for H8/3694 program development and debugging, the following restrictions must be noted.</p> <ol style="list-style-type: none"> 1. The $\overline{\text{NMI}}$ pin is reserved for the E7 or E8, and cannot be used. 3. Area H'7000 to H'7FFF is used by the E7 or E8, and is not available to the user. 5. When the E7 or E8 is used, address breaks can be set as either available to the user or for use by the E7 or E8. If address breaks are set as being used by the E7 or E8, the address break control registers must not be accessed. 6. When the E7 or E8 is used, $\overline{\text{NMI}}$ is an input/output pin (open-drain in output mode), P85 and P87 are input pins, and P86 is an output pin. <p>Note has been deleted.</p> |

Section 1 Overview 4, 5

Figure 1.1 Internal Block Diagram of H8/3694 Group of F-ZTAT™ and Mask-ROM Versions,

Figure 1.2 Internal Block Diagram of H8/3694N (EEPROM Stacked Version)

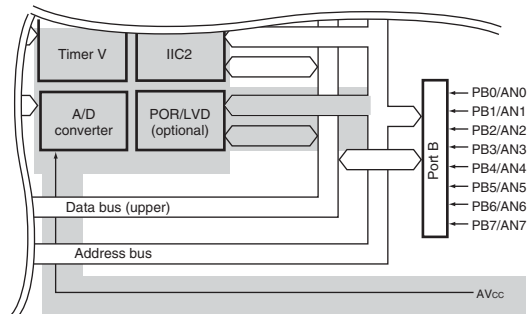

Item **Page** **Revision (See Manual for Details)**

Section 5 Clock Pulse Generators 70

Figure 5.3 Typical Connection to Crystal Resonator

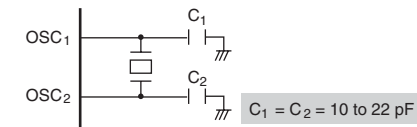
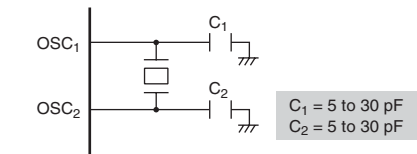

Figure 5.5 Typical Connection to Ceramic Resonator 71



Section 6 Power-Down Modes 76

6.1.1 System Control Register 1 (SYSCR1)

| Bit | Bit Name | Description |
|-----|----------|--|
| 3 | NESEL | <p>Noise Elimination Sampling Frequency Select</p> <p>The subclock pulse generator generates the watch clock signal (ϕ_w) and the system clock pulse generator generates the oscillator clock (ϕ_{osc}). This bit selects the sampling frequency of the oscillator clock when the watch clock signal (ϕ_w) is sampled. When $\phi_{osc} = 4$ to 20 MHz, clear NESEL to 0.</p> |

Section 8 RAM 107

Note: * When the E7 or E8 is used, area H'F780 to H'FB7F must not be accessed.

Section 13 Watchdog Timer 184

13.2.1 Timer Control/Status Register WD (TCSRWD)

| Bit | Bit Name | Description |
|-----|----------|--|
| 4 | TCSRWE | Timer Control/Status Register WD Write Enable |

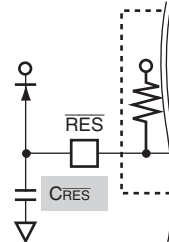
| Item | Page | Revision (See Manual for Details) | | | | | | | | | | | | | | | | | | | |
|--|----------|--|---------------------------|---------------------|-----------------|----------------|----------------|--|--------------------|----------|------------|---------------------------|---------------------|---------------------|-------------------|----------|--------------------------------------|---------------------------|------|--------------------------|------|
| Section 15 I ² C Bus Interface 2 (IIC2) 15.3.5 I ² C Bus Status Register (ICSR) | 242 | <table border="1"> <thead> <tr> <th>Bit</th> <th>Bit Name</th> <th>Description</th> </tr> </thead> <tbody> <tr> <td>3</td> <td>STOP</td> <td> Stop Condition Detection Flag [Setting conditions] <ul style="list-style-type: none"> In master mode, when a stop condition is detected after frame transfer In slave mode, when a stop condition is detected after the general call address or the first byte slave address, next to detection of start condition, accords with the address set in SAR </td> </tr> </tbody> </table> | Bit | Bit Name | Description | 3 | STOP | Stop Condition Detection Flag [Setting conditions] <ul style="list-style-type: none"> In master mode, when a stop condition is detected after frame transfer In slave mode, when a stop condition is detected after the general call address or the first byte slave address, next to detection of start condition, accords with the address set in SAR | | | | | | | | | | | | | |
| Bit | Bit Name | Description | | | | | | | | | | | | | | | | | | | |
| 3 | STOP | Stop Condition Detection Flag [Setting conditions] <ul style="list-style-type: none"> In master mode, when a stop condition is detected after frame transfer In slave mode, when a stop condition is detected after the general call address or the first byte slave address, next to detection of start condition, accords with the address set in SAR | | | | | | | | | | | | | | | | | | | |
| 15.7 Usage Notes | 264 | Added | | | | | | | | | | | | | | | | | | | |
| Section 16 A/D Converter 16.3.1 A/D Data Registers A to D (ADDRA to ADDR D) | 268 | Therefore byte access to ADDR should be done by reading the upper byte first then the lower one. Word access is also possible. ADDR is initialized to H'0000. | | | | | | | | | | | | | | | | | | | |
| Section 18 Power-On Reset and Low-Voltage Detection Circuits (Optional) | 290 |  <p>Figure 18.1 Block Diagram of Power-On Reset Circuit and Low-Voltage Detection Circuit</p> | | | | | | | | | | | | | | | | | | | |
| Section 21 Electrical Characteristics Table 21.2 DC Characteristics (1) | 318 | <table border="1"> <thead> <tr> <th rowspan="2">Item</th> <th rowspan="2">Symbol</th> <th rowspan="2">Applicable Pins</th> <th rowspan="2">Test Condition</th> <th>Values</th> </tr> <tr> <th>Min</th> </tr> </thead> <tbody> <tr> <td rowspan="2">Input high voltage</td> <td rowspan="2">V_{IH}</td> <td rowspan="2">PB0 to PB7</td> <td rowspan="2">$V_{CC} = 4.0$ to 5.5 V</td> <td>$V_{CC} \times 0.7$</td> </tr> <tr> <td>$V_{CC} \times 0.8$</td> </tr> <tr> <td rowspan="2">Input low voltage</td> <td rowspan="2">V_{IL}</td> <td>RXD,SCL, SDA, P10 to P12, :</td> <td rowspan="2">$V_{CC} = 4.0$ to 5.5 V</td> <td>-0.3</td> </tr> <tr> <td>P80 to P87 PB0 to PB7</td> <td>-0.3</td> </tr> </tbody> </table> | Item | Symbol | Applicable Pins | Test Condition | Values | Min | Input high voltage | V_{IH} | PB0 to PB7 | $V_{CC} = 4.0$ to 5.5 V | $V_{CC} \times 0.7$ | $V_{CC} \times 0.8$ | Input low voltage | V_{IL} | RXD,SCL, SDA, P10 to P12, : | $V_{CC} = 4.0$ to 5.5 V | -0.3 | P80 to P87 PB0 to PB7 | -0.3 |
| Item | Symbol | Applicable Pins | | | | | Test Condition | Values | | | | | | | | | | | | | |
| | | | Min | | | | | | | | | | | | | | | | | | |
| Input high voltage | V_{IH} | PB0 to PB7 | $V_{CC} = 4.0$ to 5.5 V | $V_{CC} \times 0.7$ | | | | | | | | | | | | | | | | | |
| | | | | $V_{CC} \times 0.8$ | | | | | | | | | | | | | | | | | |
| Input low voltage | V_{IL} | RXD,SCL, SDA, P10 to P12, : | $V_{CC} = 4.0$ to 5.5 V | -0.3 | | | | | | | | | | | | | | | | | |
| | | P80 to P87 PB0 to PB7 | | -0.3 | | | | | | | | | | | | | | | | | |

Item **Page** **Revision (See Manual for Details)**

Table 21.2 DC Characteristics (1)

| Mode | $\overline{\text{RES}}$ Pin | Internal State |
|---------------|-----------------------------|--|
| Active mode 1 | V_{CC} | Operates |
| Active mode 2 | | Operates ($\phi\text{OSC}/64$) |
| Sleep mode 1 | V_{CC} | Only timers operate |
| Sleep mode 2 | | Only timers operate ($\phi\text{OSC}/64$) |

Table 21.12 DC Characteristics (1)

| Item | Symbol | Applicable Pins | Test Condition | Values |
|--------------------|-----------------|---|----------------------------------|----------------------------|
| | | | | Min |
| Input high voltage | V_{IH} | PB0 to PB7 | $V_{\text{CC}} = 4.0$ to 5.5 V | $V_{\text{CC}} \times 0.7$ |
| | | | | $V_{\text{CC}} \times 0.8$ |
| Input low voltage | V_{IL} | RXD, SCL, SDA P10 to P12, : P80 to P87 PB0 to PB7 | $V_{\text{CC}} = 4.0$ to 5.5 V | -0.3 |
| | | | | -0.3 |

| Mode | $\overline{\text{RES}}$ Pin | Internal State |
|---------------|-----------------------------|--|
| Active mode 1 | V_{CC} | Operates |
| Active mode 2 | | Operates ($\phi\text{OSC}/64$) |
| Sleep mode 1 | V_{CC} | Only timers operate |
| Sleep mode 2 | | Only timers operate ($\phi\text{OSC}/64$) |

Figure 21.4 I²C Bus Interface Input/Output Timing

352

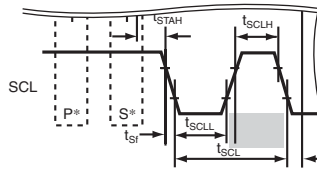

Appendix D Package Dimensions

405 to 409 Swapped with new ones.

Index

| | |
|---|-----|
| A | |
| A/D converter | 265 |
| Sample-and-hold circuit..... | 272 |
| Scan mode..... | 271 |
| Single mode..... | 271 |
| Address break | 63 |
| Addressing modes..... | 34 |
| Absolute address..... | 36 |
| Immediate | 36 |
| Memory indirect | 37 |
| Program-counter relative | 36 |
| Register direct..... | 35 |
| Register indirect..... | 35 |
| Register indirect with displacement..... | 35 |
| Register indirect with post-increment... | 35 |
| Register indirect with pre-decrement.... | 36 |
| C | |
| Clock pulse generators..... | 69 |
| Prescaler S | 73 |
| Prescaler W..... | 73 |
| Subclock generator | 72 |
| System clock generator..... | 70 |
| Condition field..... | 33 |
| Condition-code register (CCR)..... | 19 |
| CPU | 13 |
| E | |
| EEPROM..... | 277 |
| Acknowledge..... | 281 |
| Acknowledge polling..... | 284 |
| Byte write | 283 |
| Current address read | 285 |
| EEPROM interface | 280 |
| Page write | 283 |
| Random address read | 286 |
| Sequential read..... | 286 |
| Slave address reference register (ESAR)..... | 281 |
| Slave addressing..... | 281 |
| Start condition..... | 280 |
| Stop condition | 281 |
| Effective address | 38 |
| Effective address extension..... | 33 |
| Exception handling | 49 |
| Reset exception handling | 56 |
| Trap instruction..... | 49 |
| F | |
| Flash memory | 87 |
| Boot mode..... | 93 |
| Boot program | 93 |
| Erase/erase-verify | 100 |
| Erasing units | 87 |
| Error protection..... | 103 |
| Hardware protection..... | 103 |
| Power-down state..... | 104 |
| Program/program-verify | 98 |
| Programmer mode..... | 104 |
| Programming units..... | 87 |
| Programming/erasing in user program mode | 96 |
| Software protection..... | 103 |
| G | |
| General registers | 18 |
| I | |
| I/O ports | 109 |

| | |
|---|-----|
| I/O port block diagrams | 385 |
| I ² C bus data format | 246 |
| I ² C bus interface 2 (IIC2) | 231 |
| Acknowledge | 247 |
| Bit synchronous circuit | 263 |
| Clocked synchronous serial format..... | 255 |
| Noise canceler | 257 |
| Slave address | 246 |
| Start condition | 246 |
| Stop condition..... | 247 |
| Transfer rate..... | 235 |
| Instruction set | 24 |
| Arithmetic operations instructions..... | 26 |
| Bit Manipulation instructions | 29 |
| Block data transfer instructions | 33 |
| Branch instructions | 31 |
| Data transfer instructions..... | 25 |
| Logic operations instructions..... | 28 |
| Shift instructions..... | 28 |
| System control instructions..... | 32 |
| Internal power supply step-down circuit | 299 |
| Interrupt | |
| Internal interrupts | 58 |
| Interrupt response time | 60 |
| IRQ3 to IRQ0 interrupts | 57 |
| NMI interrupt..... | 57 |
| WKP5 to WKP0 interrupts | 57 |
| Interrupt mask bit (I)..... | 19 |

L

| | |
|---|-----|
| Large current ports..... | 2 |
| Low-voltage detection circuit | 289 |
| LVDI | 295 |
| LVDI (interrupt by low voltage detect) circuit..... | 295 |
| LVDR | 294 |
| LVDR (reset by low voltage detect) circuit | 294 |

M

| | |
|-------------------------------|----|
| Memory map..... | 14 |
| Module standby function | 86 |

O

| | |
|----------------------------------|----|
| On-board programming modes | 93 |
| Operation field..... | 33 |

P

| | |
|------------------------------|-----|
| Package | 3 |
| Package dimensions..... | 405 |
| Pin arrangement | 6 |
| Power-down modes..... | 75 |
| Sleep mode..... | 83 |
| Standby mode | 83 |
| Subactive mode..... | 84 |
| Subsleep mode | 83 |
| Power-on reset | 289 |
| Power-on reset circuit | 293 |
| Product code lineup | 402 |
| Program counter (PC)..... | 19 |

R

Register

| | |
|--------------|--------------------|
| ABRKCR | 64, 304, 309, 312 |
| ABRKSR | 65, 304, 309, 312 |
| ADCR | 270, 304, 308, 312 |
| ADCSR | 269, 304, 308, 312 |
| ADDRA | 268, 303, 308, 312 |
| ADDRB | 268, 304, 308, 312 |
| ADDRC | 268, 304, 308, 312 |
| ADDRD | 268, 304, 308, 312 |
| BARH | 66, 304, 309, 312 |
| BARL..... | 66, 304, 309, 312 |
| BDRH | 66, 304, 309, 312 |
| BDRL..... | 66, 304, 309, 312 |
| BRR | 198, 303, 308, 312 |

| | | | |
|--------------|--------------------|----------------------------------|--------------------|
| EBR1 | 91, 303, 308, 311 | PUCR5 | 120, 305, 309, 312 |
| EKR | 279, 306, 310, 313 | RDR | 192, 303, 308, 312 |
| FENR | 92, 303, 308, 311 | RSR | 192 |
| FLMCR1 | 89, 303, 308, 311 | SAR | 244, 302, 307, 311 |
| FLMCR2 | 90, 303, 308, 311 | SCR3 | 194, 303, 308, 312 |
| FLPWCR | 92, 303, 308, 311 | SMR | 193, 303, 308, 312 |
| GRA | 165, 302, 307, 311 | SSR | 196, 303, 308, 312 |
| GRB | 165, 303, 307, 311 | SYSCR1 | 76, 306, 309, 313 |
| GRC | 165, 303, 307, 311 | SYSCR2 | 78, 306, 309, 313 |
| GRD | 165, 303, 307, 311 | TCA | 134, 303, 308, 312 |
| ICCR1 | 234, 302, 307, 311 | TCNT | 164, 302, 307, 311 |
| ICCR2 | 236, 302, 307, 311 | TCNTV | 139, 303, 308, 312 |
| ICDRR | 245, 302, 307, 311 | TCORA | 139, 303, 308, 311 |
| ICDRS | 245 | TCORB | 139, 303, 308, 311 |
| ICDRT | 245, 302, 307, 311 | TCRV0 | 140, 303, 308, 311 |
| ICIER | 239, 302, 307, 311 | TCRV1 | 143, 303, 308, 312 |
| ICMR | 237, 302, 307, 311 | TCRW | 158, 302, 307, 311 |
| ICSR | 241, 302, 307, 311 | TCSRV | 142, 303, 308, 311 |
| IEGR1 | 51, 306, 309, 313 | TCSRWD | 184, 304, 308, 312 |
| IEGR2 | 52, 306, 309, 313 | TCWD | 185, 304, 308, 312 |
| IENR1 | 53, 306, 309, 313 | TDR | 192, 303, 308, 312 |
| IRR1 | 54, 306, 309, 313 | TIERW | 159, 302, 307, 311 |
| IWPR | 55, 306, 309, 313 | TIOR0 | 161, 302, 307, 311 |
| LVDCR | 290, 302, 307, 311 | TIOR1 | 163, 302, 307, 311 |
| LVDSR | 292, 302, 307, 311 | TMA | 133, 303, 308, 312 |
| MSTCR1 | 79, 306, 309, 313 | TMRW | 157, 302, 307, 311 |
| PCR1 | 111, 305, 309, 313 | TMWD | 186, 304, 309, 312 |
| PCR2 | 115, 305, 309, 313 | TSR | 192 |
| PCR5 | 119, 305, 309, 313 | TSRW | 160, 302, 307, 311 |
| PCR7 | 124, 305, 309, 313 | Register field | 33 |
| PCR8 | 126, 305, 309, 313 | | |
| PDR1 | 111, 305, 309, 312 | | |
| PDR2 | 115, 305, 309, 312 | S | |
| PDR5 | 119, 305, 309, 312 | Serial communication interface 3 | |
| PDR7 | 124, 305, 309, 312 | (SCI3) | 189 |
| PDR8 | 127, 305, 309, 312 | Asynchronous mode | 205 |
| PDRB | 130, 305, 309, 312 | Bit rate | 198 |
| PMR1 | 110, 305, 309, 313 | Break | 229 |
| PMR5 | 118, 305, 309, 313 | Clocked synchronous mode | 213 |
| PUCR1 | 112, 305, 309, 312 | Framing error | 209 |

| | |
|---|-----|
| Mark state | 229 |
| Multiprocessor communication function..... | 221 |
| Overrun error | 209 |
| Parity error..... | 209 |
| Stacked-structure cross sectional view of H8/3694N | 410 |
| Stack pointer (SP)..... | 19 |

T

| | |
|---------------|-----|
| Timer A | 131 |
|---------------|-----|

| | |
|--------------|-----|
| Timer V..... | 137 |
| Timer W..... | 153 |

V

| | |
|---------------------|----|
| Vector address..... | 49 |
|---------------------|----|

W

| | |
|---------------------|-----|
| Watchdog timer..... | 183 |
|---------------------|-----|

**Renesas 16-Bit Single-Chip Microcomputer
Hardware Manual
H8/3694 Group**

Publication Date: 1st Edition, Jul, 2001

Rev.5.00, Nov. 02, 2005

Published by: Sales Strategic Planning Div.

Renesas Technology Corp.

Edited by: Customer Support Department

Global Strategic Communication Div.

Renesas Solutions Corp.

Renesas Technology Corp. Sales Strategic Planning Div. Nippon Bldg., 2-6-2, Ohte-machi, Chiyoda-ku, Tokyo 100-0004, Japan



RENESAS SALES OFFICES

<http://www.renesas.com>

Refer to "<http://www.renesas.com/en/network>" for the latest and detailed information.

Renesas Technology America, Inc.

450 Holger Way, San Jose, CA 95134-1368, U.S.A
Tel: <1> (408) 382-7500, Fax: <1> (408) 382-7501

Renesas Technology Europe Limited

Dukes Meadow, Millboard Road, Bourne End, Buckinghamshire, SL8 5FH, United Kingdom
Tel: <44> (1628) 585-100, Fax: <44> (1628) 585-900

Renesas Technology (Shanghai) Co., Ltd.

Unit2607 Ruijing Building, No.205 Maoming Road (S), Shanghai 200020, China
Tel: <86> (21) 6472-1001, Fax: <86> (21) 6415-2952

Renesas Technology Hong Kong Ltd.

7th Floor, North Tower, World Finance Centre, Harbour City, 1 Canton Road, Tsimshatsui, Kowloon, Hong Kong
Tel: <852> 2265-6688, Fax: <852> 2730-6071

Renesas Technology Taiwan Co., Ltd.

10th Floor, No.99, Fushing North Road, Taipei, Taiwan
Tel: <886> (2) 2715-2888, Fax: <886> (2) 2713-2999

Renesas Technology Singapore Pte. Ltd.

1 Harbour Front Avenue, #06-10, Keppel Bay Tower, Singapore 098632
Tel: <65> 6213-0200, Fax: <65> 6278-8001

Renesas Technology Korea Co., Ltd.

Kukje Center Bldg. 18th Fl., 191, 2-ka, Hangang-ro, Yongsan-ku, Seoul 140-702, Korea
Tel: <82> 2-796-3115, Fax: <82> 2-796-2145

Renesas Technology Malaysia Sdn. Bhd.

Unit 906, Block B, Menara Amcorp, Amcorp Trade Centre, No.18, Jalan Persiaran Barat, 46050 Petaling Jaya, Selangor Darul Ehsan, Malaysia
Tel: <603> 7955-9390, Fax: <603> 7955-9510



H8/3694Group Hardware Manual



Renesas Electronics Corporation

1753, Shimonumabe, Nakahara-ku, Kawasaki-shi, Kanagawa 211-8668 Japan

REJ09B0028-0500