

FX-500 Low Jitter Frequency Translator

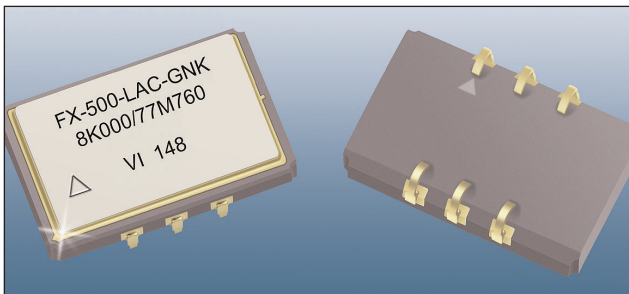

Description

The FX-500 is a complete crystal-based frequency translator used in communications applications where low jitter is paramount.

Performance advantages include superior jitter performance, high output frequencies and small package size. Advanced custom ASIC technology results in a highly robust, reliable and predictable device.

The device is packaged in a 6 pin J-Lead ceramic package with a hermetic seam welded lid.

Features

- Complete Frequency Translator to 77.760 MHz
- 3.3 Volt or 5.0 Volt Supply
- Capable of locking to an 8 kHz pulse/ BITS clock
- Tri-State Output allows board test
- Lock Detect
- J-Lead Ceramic Package
- Advanced Custom ASIC Technology
- Absolute Pull Range Performance to ± 100 ppm
- CMOS Output
- Commercial or Industrial Temperature Range
- EIA Compatible Tape and Reel Packaging

Applications

- Frequency Translation, Clock Smoothing
- Telecom - SONET/SDH/ATM/DWDM
- Datacom - DSLAM, DSLAR, Access Nodes
- Cable Modem Head End
- Base Station - GSM, CDMA

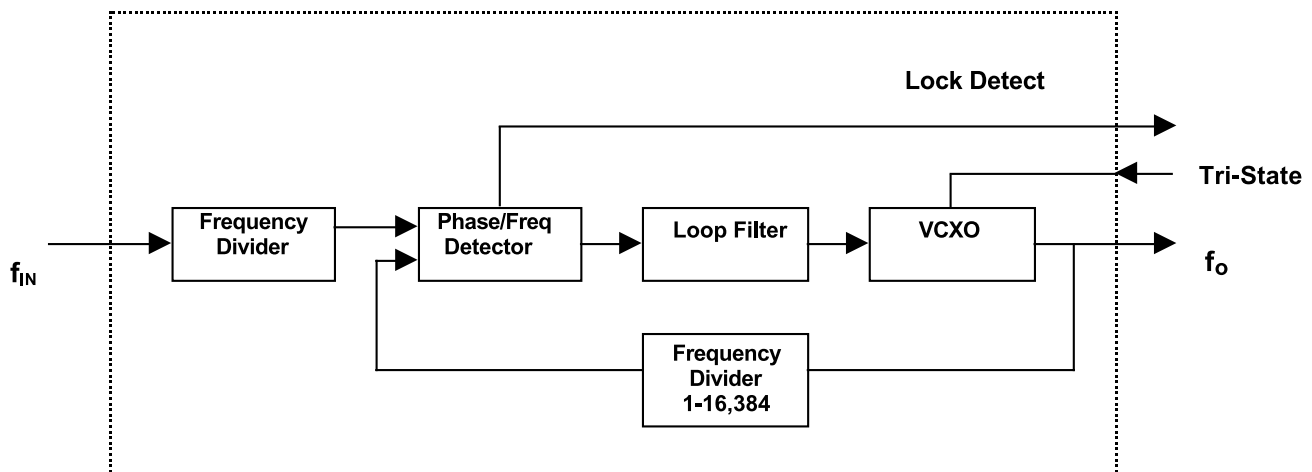

Figure 1. FX-500 Block Diagram

FX-500 Low Jitter Frequency Translator

Performance Characteristics

Electrical Performance

Parameter	Symbol	Minimum	Typical	Maximum	Units
Output Frequency ⁴	f_o	0.100		77.76	MHz
Supply Voltage ¹	V_{DD}	3.0	3.3	3.6	V
	V_{DD}	4.5	5.0	5.5	V
Supply Current @ 19.44MHz 48.408MHz 77.760MHz	I_{DD}		15	20	mA
	I_{DD}		25	30	mA
	I_{DD}		35	40	mA
Input Input Low Level Voltage Input High Level Voltage Frequency Pulse Width	V_{IL}			$0.3 * V_{DD}$	V
	V_{IH}	$0.7 * V_{DD}$			V
	f_{IN}	1k		77.76M	Hz
Output ² Output High Level Voltage Output Low Level Voltage	V_{OH}	$0.9 * V_{DD}$			V
	V_{OL}			$0.1 * V_{DD}$	V
Transition times ² Rise Time Fall Time	t_R		1.8	3.0	ns
	t_F		1.8	3.0	ns
Duty Cycle ³ ≤60MHz >60MHz	D	45		55	%
	D	40		60	%
Absolute Pull Range	APR	See Part Numbering			ppm
Leakage Current of Input	I_c	-1		1	μA
Loop Bandwidth (-3 dB), 8kHz input	BW		10		Hz
Jitter (Application: 8 kHz to 77.760 MHz translation) rms peak/peak peak/peak			4.7		ps
			44		ps
			0.003		UI
Size		14mm x 9mm x 4.5 mm			

1. A 0.1 μF low frequency tantalum bypass capacitor in parallel with a 0.01 μF high frequency ceramic capacitor is recommended.
2. Figure 2 defines the waveform parameters. Figure 3 illustrates the standard test conditions under which these parameters are specified and tested.
3. Duty cycle is defined as (on time ÷ period), with $V_S = V_{DD}/2$, per Figure 2. Duty cycle is measured with a 15pf load per Figure 3.
4. Other frequencies may be available, please contact factory.

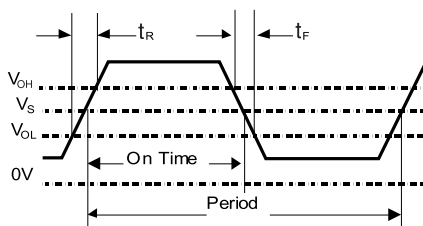

Figure 2. Output Waveform

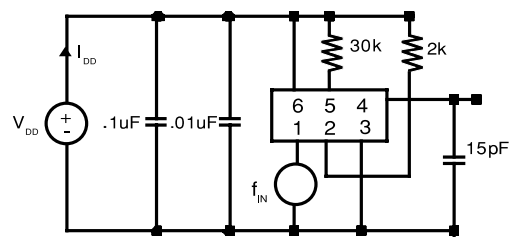
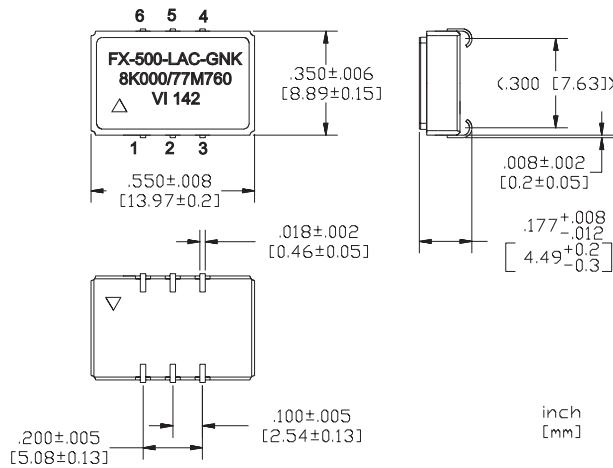

Figure 3. Output Test Conditions
(25 ±5°C)

FX-500 Low Jitter Frequency Translator

Outline Diagram



Pad Layout

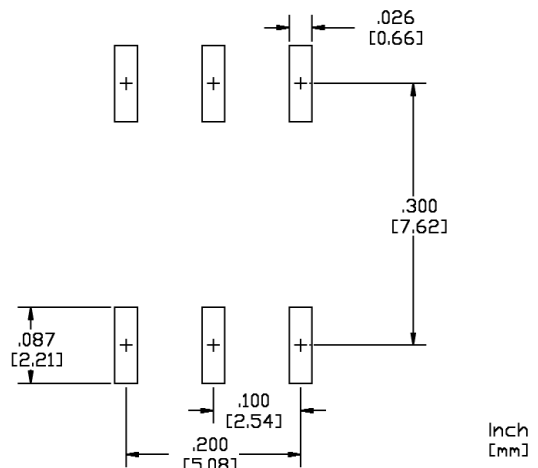

Pin Out

Pin #	Symbol	Function
1	f_{IN}	Input Frequency
2	Tri-state ¹	Logic Low = Output Disable / Logic High = Output Enabled
3	GND	Case and Electrical Ground
4	F_O	Output Frequency
5	LD ²	Lock Detect
6	V _{DD}	Power Supply Voltage (3.3 V ± 0.3 or 5.0 V ± 0.5)

1. Tri-state is driven to logic high or logic low; there is no internal pull up or pull down resistor.
2. LD is an open collector output requiring a 30k ohm pullup resistor to V_{DD}. LD output is logic high under locked condition, logic low for no input at f_{IN} , and for "out-of-lock" condition LD transitions between logic low and logic high at the phase detector frequency.

Tape and Reel

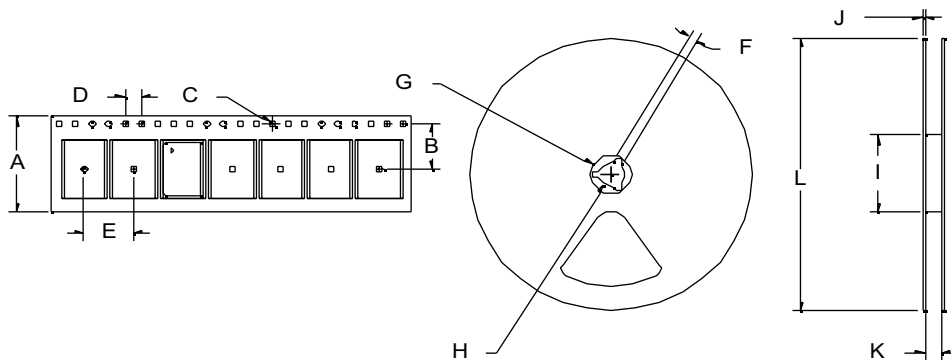

Tape and Reel Dimensions (mm)

Product	Tape Dimensions					Reel Dimensions							# Per Reel
	A	B	C	D	E	F	G	H	I	J	K	L	
FX-500	24	11.5	1.5	4	12	1.78	21	13	100	5	25	330	200

FX-500 Low Jitter Frequency Translator

Absolute Maximum Ratings

Stresses in excess of the absolute maximum ratings can permanently damage the device. Functional operation is not implied at these or any other conditions in excess of conditions represented in the operational sections of this data sheet. Exposure to absolute maximum ratings for extended periods may adversely affect device reliability.

Parameter	Symbol	Ratings	Unit
Power Supply	V _{DD}	7	Vdc
Storage Temperature	T _{storage}	-55/125	°C

Reliability

Absolute Maximum Ratings

Parameter	Conditions
Mechanical Shock	MIL-STD-883 Method 2002/Test A
Mechanical Vibration	MIL-STD-883 Method 2007/Test A
Lead Solderability	MIL-STD-883 Method 2003
Gross and Fine Leak	MIL-STD-883 Method 1014

Handling Precautions

Although ESD protection circuitry has been designed into this device, proper precautions should be taken when handling and mounting. VI employs a Human Body Model and a charged device model for ESD-susceptibility testing and design protection evaluation. ESD thresholds are dependent on the circuit parameters used to define the model. Although no industry wide standard has been adopted for the CDM, a standard HBM of resistance = 1500Ω and capacitance = 100pf is widely used and therefore can be used for comparison purposes.

ESD Ratings

Model	Minimum	Conditions
Mechanical Shock	1000V	MIL-STD-883, Method 3015
Mechanical Vibration	1000V	JESD22-C101

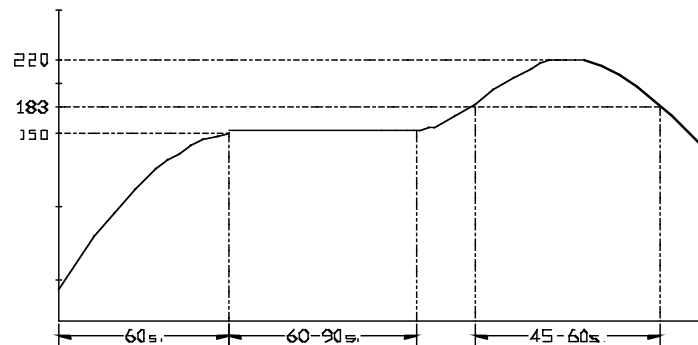

Figure 6. Suggested Reflow Profile

FX-500 Low Jitter Frequency Translator

Standard Frequencies

1.000 kHz A1	4.000 kHz A2	8.000 kHz A3	16.000 kHz A4	64.000 kHz A5	1.024 MHz B2
1.544 MHz B3	2.048 MHz B4	3.088 MHz B6	4.096 MHz B5	6.480 MHz C2	8.192 MHz C3
10.000 MHz C4	12.352 MHz D1	13.000 MHz D3	15.000 MHz D4	16.384 MHz D5	18.432 MHz D7
19.440 MHz D6	20.000 MHz E2	20.480 MHz E4	24.576 MHz E6	24.704 MHz E7	26.000 MHz F3
27.000 MHz F4	30.720 MHz H1	32.000 MHz H2	32.768 MHz H3	34.368 MHz H6	37.056 MHz H4
38.880 MHz H5	40.960 MHz J1	44.736 MHz J3	49.152 MHz J7	51.840 MHz J4	61.440 MHz J5
62.208 MHz J8	62.500 MHz J9	65.536 MHz J6	74.152 MHz K1	74.250 MHz K7	77.760 MHz K2

Note 1: Other frequencies are available upon request, please contact VI for details

SS is code for non-standard frequencies, list the frequency after the part number.

Note 2: Not all combinations are possible.

Note 3: Output frequency must be equal to or greater than the input frequency. The ratio of f_o/f_{IN} must be an Integer.

Also, the output frequency must be equal to or greater than 100 kHz.

Ordering Information

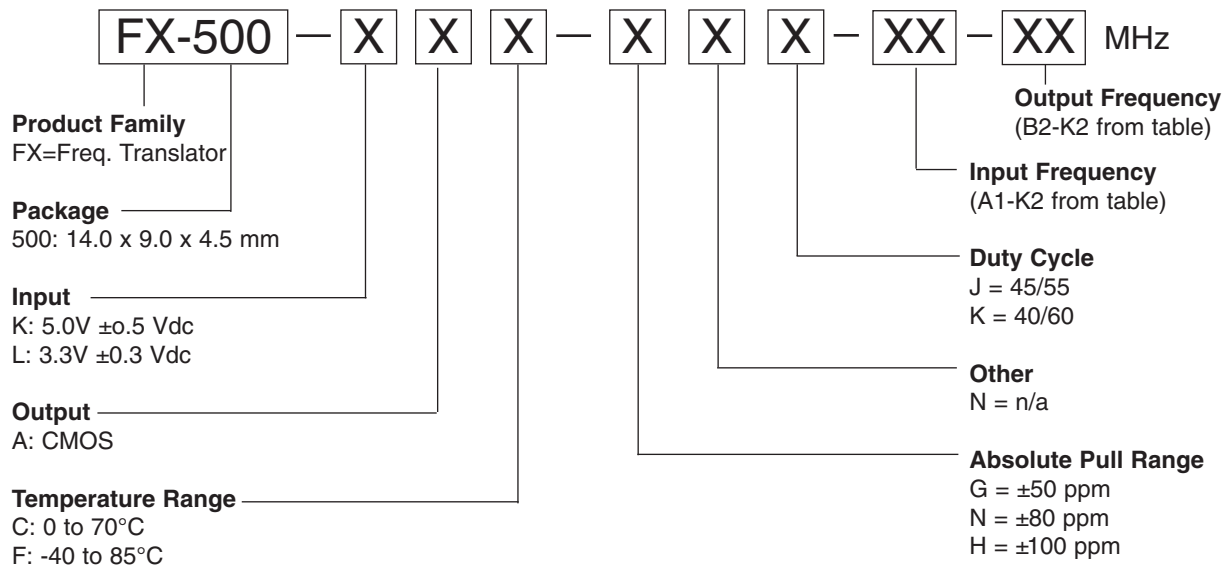

EXAMPLE: FX-500-LAC-GNK-A3-K2

FX-500, 3.3V, CMOS output, 0 to 70C operating temperature,

±50 ppm APR, 40/60 % duty cycle with an 8kHz input and 77.760MHz output

FX-500 Low Jitter Frequency Translator

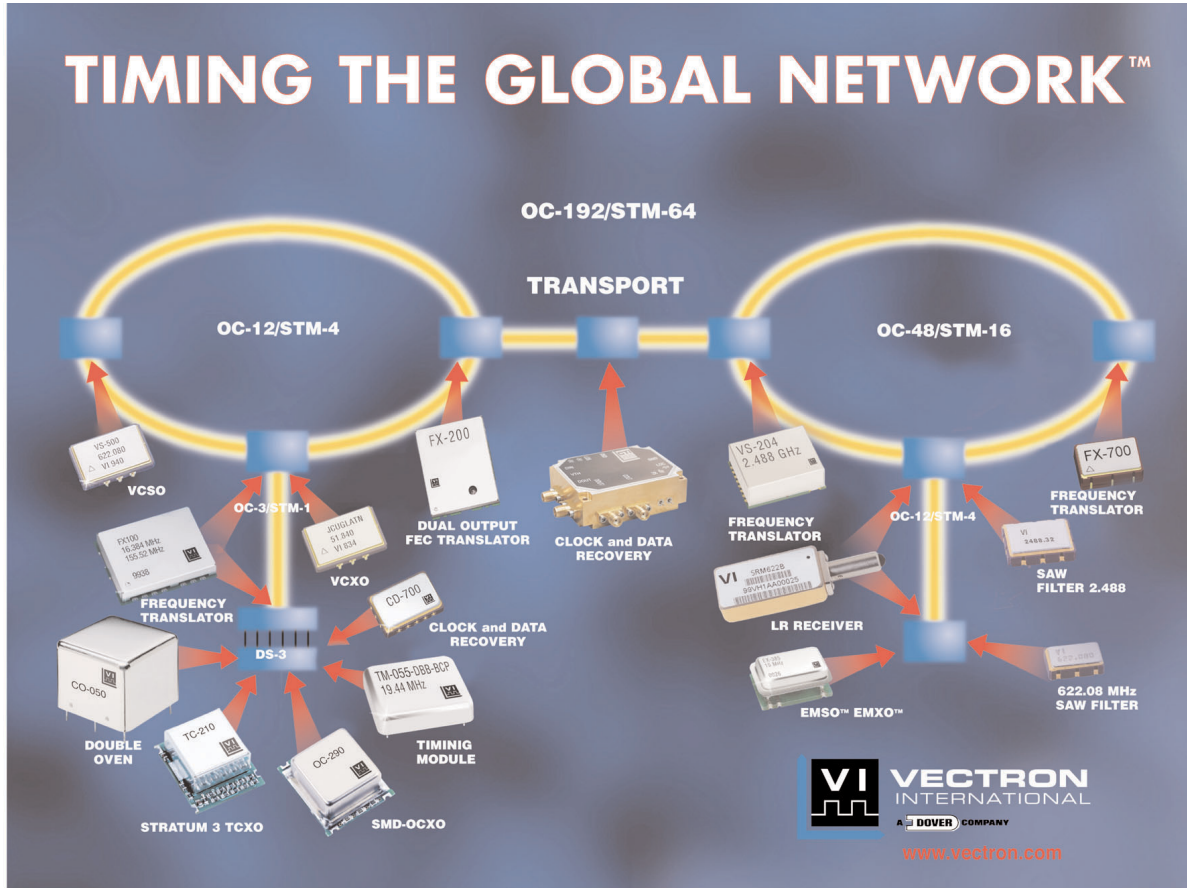

For additional information please contact:



USA: Vectron International • 267 Lowell Road, Hudson, NH 03051 Tel: 1-88-VECTRON-1 • Fax: 1-888-FAX-VECTRON
 EUROPE: Tel: 49 (0) 3328 4784 17 * Fax: 49 (0) 3328 4784 30
 ASIA: Tel: +86 21 28909740 / 41 / 42 Fax: +86 21 28909240 / 28909999

www.vectron.com

Vectron International reserves the right to make changes to the product(s) and/or information contained herein without notice.
 No liability is assumed as a result of their use or application. No rights under any patent accompany the sale of any such product(s) or information.
 ©2001, Vectron International. Rev.25Mar02, 20Aug02