

# FM220-MHT THRU FM2200-MHT

## List

List.....	1
Package outline.....	2
Features.....	2
Mechanical data.....	2
Maximum ratings .....	2
Rating and characteristic curves.....	3
Pinning information.....	4
Marking.....	4
Suggested solder pad layout.....	4
Packing information.....	5
Reel packing.....	6
Suggested thermal profiles for soldering processes.....	6
High reliability test capabilities.....	7

# FM220-MHT THRU FM2200-MHT

## 2.0A Surface Mount Schottky Barrier Rectifiers - 20V-200V

### Features

- Batch process design, excellent power dissipation offers better reverse leakage current and thermal resistance.
- Low profile surface mounted application in order to optimize board space.
- Tiny plastic SMD package.
- Low power loss, high efficiency.
- High current capability, low forward voltage drop.
- High surge capability.
- Guardring for overvoltage protection.
- Ultra high-speed switching.
- Silicon epitaxial planar chip, metal silicon junction.
- Lead-free parts meet environmental standards of MIL-STD-19500 / 228
- Suffix "-H" indicates Halogen-free part, ex.FM220-MHT-H.

### Mechanical data

- Epoxy : UL94-V0 rated flame retardant
- Case : Molded plastic, SOD-123HT
- Terminals :Plated terminals, solderable per MIL-STD-750, Method 2026
- Polarity : Indicated by cathode band
- Mounting Position : Any
- Weight : Approximated 0.011 gram

### Package outline

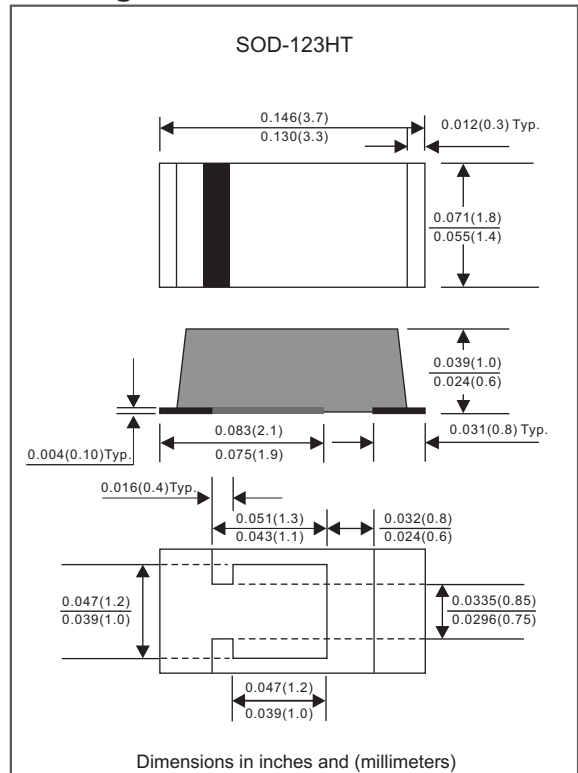

### Maximum ratings and Electrical Characteristics (AT T<sub>A</sub>=25°C unless otherwise noted)

PARAMETER	CONDITIONS	Symbol	MIN.	TYP.	MAX.	UNIT
Forward rectified current	See Fig.1	I <sub>O</sub>			2.0	A
Forward surge current	8.3ms single half sine-wave (JEDEC methode)	I <sub>FSM</sub>			50	A
Reverse current	V <sub>R</sub> = V <sub>RRM</sub> T <sub>J</sub> = 25°C	I <sub>R</sub>			0.2	mA
	V <sub>R</sub> = V <sub>RRM</sub> T <sub>J</sub> = 100°C				10	
Thermal resistance	Junction to ambient	R <sub>θJA</sub>		72		°C/W
	Junction to case	R <sub>θJC</sub>		36		°C/W
Diode junction capacitance	f=1MHz and applied 4V DC reverse voltage	C <sub>J</sub>		160		pF
Storage temperature		T <sub>STG</sub>	-65		+175	°C

SYMBOLS	V <sub>RRM</sub> <sup>*1</sup> (V)	V <sub>RMS</sub> <sup>*2</sup> (V)	V <sub>R</sub> <sup>*3</sup> (V)	V <sub>F</sub> <sup>*4</sup> (V)	Operating temperature T <sub>J</sub> , (°C)
FM220-MHT	20	14	20	0.50	-55 to +125
FM230-MHT	30	21	30		
FM240-MHT	40	28	40		
FM250-MHT	50	35	50	0.70	-55 to +150
FM260-MHT	60	42	60		
FM280-MHT	80	56	80		
FM2100-MHT	100	70	100	0.85	
FM2150-MHT	150	105	150		
FM2200-MHT	200	140	200		

\*1 Repetitive peak reverse voltage

\*2 RMS voltage

\*3 Continuous reverse voltage

\*4 Maximum forward voltage@I<sub>F</sub>=2.0A

## Rating and characteristic curves (FM220-MHT THRU FM2200-MHT)

FIG.1-TYPICAL FORWARD CURRENT DERATING CURVE

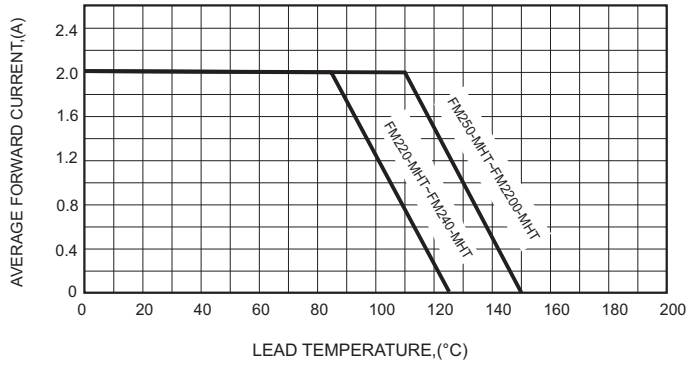

FIG.2-TYPICAL FORWARD CHARACTERISTICS

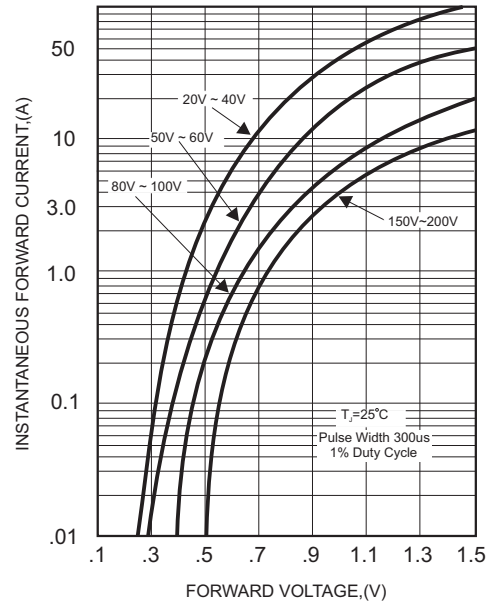

FIG.3-MAXIMUM NON-REPETITIVE FORWARD SURGE CURRENT

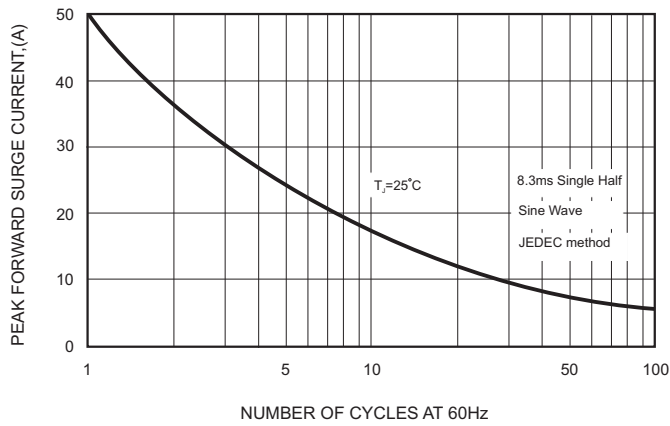

FIG.4-TYPICAL JUNCTION CAPACITANCE

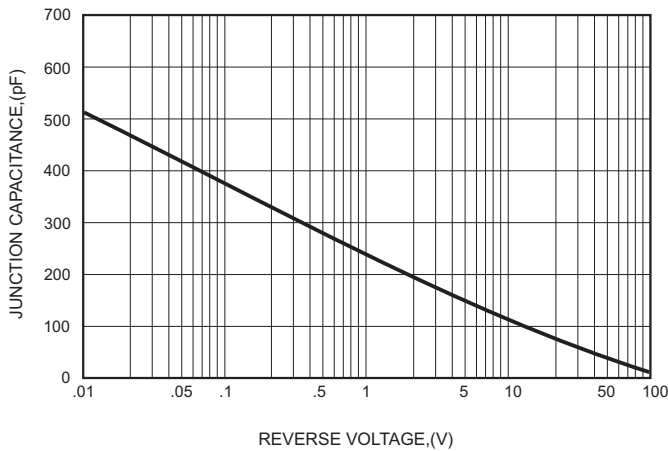
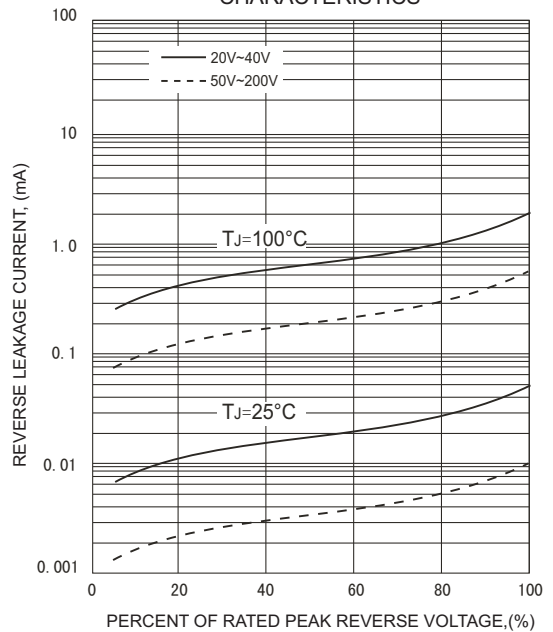



FIG.5 - TYPICAL REVERSE CHARACTERISTICS



# FM220-MHT THRU FM2200-MHT

## Pinning information

Pin	Simplified outline	Symbol
Pin1 cathode Pin2 anode		

## Marking

Type number	Marking code
FM220-MHT	22
FM230-MHT	23
FM240-MHT	24
FM250-MHT	25
FM260-MHT	26
FM280-MHT	28
FM2100-MHT	20
FM2150-MHT	215
FM2200-MHT	220

## Suggested solder pad layout

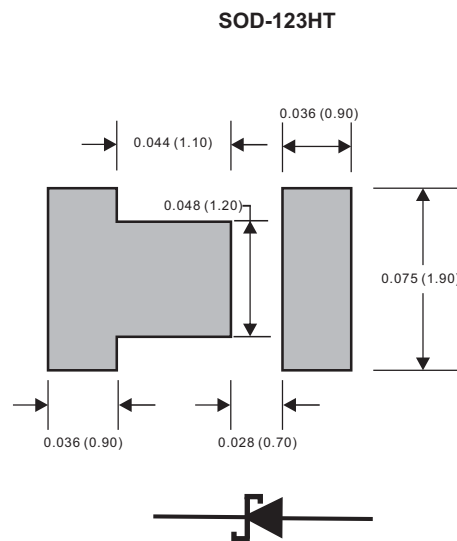

Dimensions in inches and (millimeters)

# FM220-MHT THRU FM2200-MHT

## Packing information

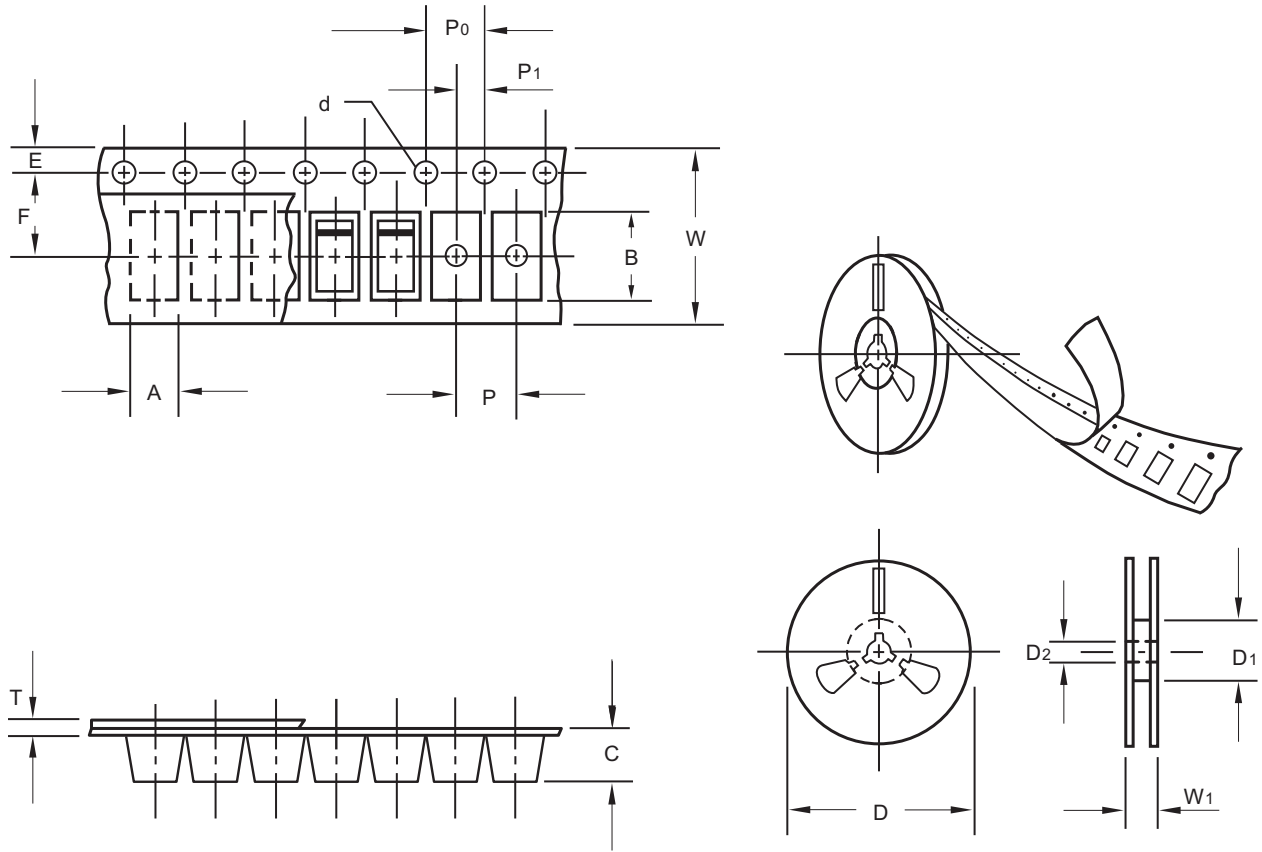

unit:mm

Item	Symbol	Tolerance	SOD-123HT
Carrier width	A	0.1	2.00
Carrier length	B	0.1	3.85
Carrier depth	C	0.1	1.10
Sprocket hole	d	0.1	1.50
13" Reel outside diameter	D	2.0	-
13" Reel inner diameter	D <sub>1</sub>	min	-
7" Reel outside diameter	D	2.0	178.00
7" Reel inner diameter	D <sub>1</sub>	min	62.00
Feed hole diameter	D <sub>2</sub>	0.5	13.00
Sprocket hole position	E	0.1	1.75
Punch hole position	F	0.1	3.50
Punch hole pitch	P	0.1	4.00
Sprocket hole pitch	P <sub>0</sub>	0.1	4.00
Embossment center	P <sub>1</sub>	0.1	2.00
Overall tape thickness	T	0.1	0.23
Tape width	W	0.3	8.00
Reel width	W <sub>1</sub>	1.0	11.40

Note: Devices are packed in accordance with EIA standard RS-481-A and specifications listed above.

# FM220-MHT THRU FM2200-MHT

## Reel packing

PACKAGE	REEL SIZE	REEL (pcs)	COMPONENT SPACING (m/m)	BOX (pcs)	INNER BOX (m/m)	REEL DIA, (m/m)	CARTON SIZE (m/m)	CARTON (pcs)	APPROX. GROSS WEIGHT (kg)
SOD-123HT	7"	3,000	4.0	30,000	183*123*183	178	382*257*387	240,000	9.0

## Suggested thermal profiles for soldering processes

- 1.Storage environment: Temperature=5°C~40°C Humidity=55%±25%
- 2.Reflow soldering of surface-mount devices

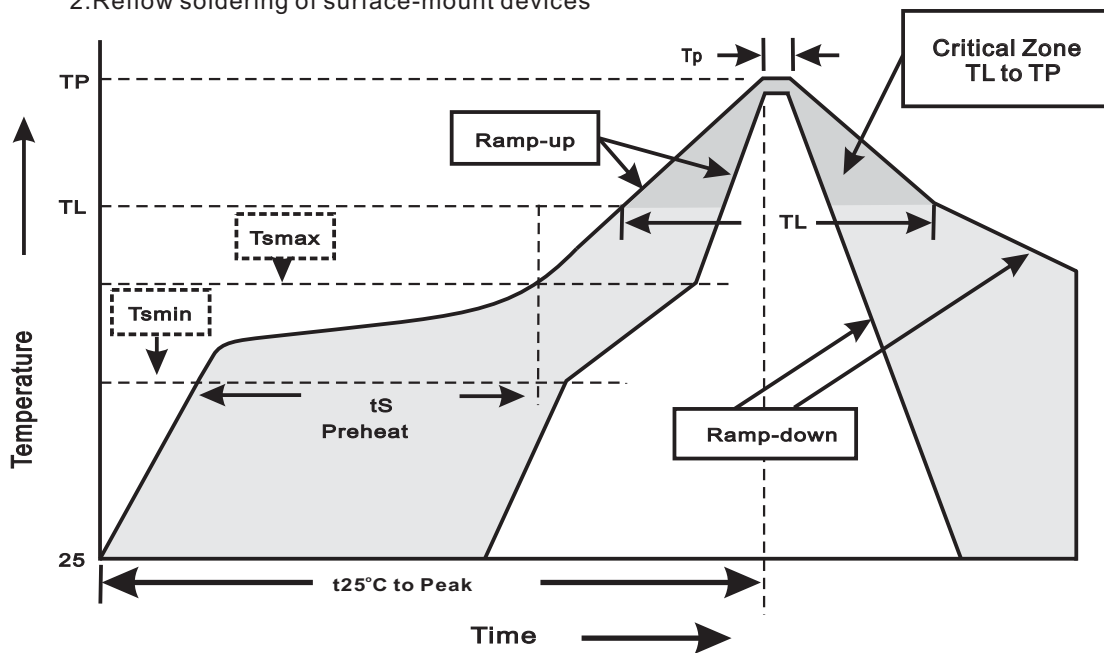

### 3.Reflow soldering

Profile Feature	Soldering Condition
Average ramp-up rate(T <sub>L</sub> to T <sub>P</sub> )	<3°C/sec
Preheat -Temperature Min(T <sub>smmin</sub> ) -Temperature Max(T <sub>smmax</sub> ) -Time(min to max)(t <sub>s</sub> )	150°C 200°C 60~120sec
T <sub>smmax</sub> to T <sub>L</sub> -Ramp-upRate	<3°C/sec
Time maintained above: -Temperature(T <sub>L</sub> ) -Time(t <sub>L</sub> )	217°C 60~260sec
Peak Temperature(T <sub>P</sub> )	255°C-0/+5°C
Time within 5°C of actual Peak Temperature(t <sub>P</sub> )	10~30sec
Ramp-down Rate	<3°C/sec
Time 25°C to Peak Temperature	<6minutes

**FM220-MHT THRU FM2200-MHT****High reliability test capabilities**

Item Test	Conditions	Reference
1. Solder Resistance	at $260\pm 5^{\circ}\text{C}$ for $10\pm 2\text{sec.}$ immerse body into solder $1/16''\pm 1/32''$	MIL-STD-750D METHOD-2031
2. Solderability	at $245\pm 5^{\circ}\text{C}$ for 5 sec.	MIL-STD-202F METHOD-208
3. High Temperature Reverse Bias	$V_R=80\%$ rate at $T_J=125^{\circ}\text{C}$ for 168 hrs.	MIL-STD-750D METHOD-1038
4. Forward Operation Life	Rated average rectifier current at $T_A=25^{\circ}\text{C}$ for 500hrs.	MIL-STD-750D METHOD-1027
5. Intermittent Operation Life	$T_A = 25^{\circ}\text{C}$ , $I_F = I_o$ On state: power on for 5 min. off state: power off for 5 min. on and off for 500 cycles.	MIL-STD-750D METHOD-1036
6. Pressure Cooker	$15P_{SIG}$ at $T_A=121^{\circ}\text{C}$ for 4 hrs.	JESD22-A102
7. Temperature Cycling	$-55^{\circ}\text{C}$ to $+125^{\circ}\text{C}$ dwelled for 30 min. and transferred for 5min. total 10 cycles.	MIL-STD-750D METHOD-1051
8. Forward Surge	8.3ms single half sine-wave , one surge.	MIL-STD-750D METHOD-4066-2
9. Humidity	at $T_A=85^{\circ}\text{C}$ , RH=85% for 1000hrs.	MIL-STD-750D METHOD-1021
10. High Temperature Storage Life	at $175^{\circ}\text{C}$ for 1000 hrs.	MIL-STD-750D METHOD-1031