

## FLI8125

### Single-Chip LCD and CRT TV Controller

#### APPLICATION

- Cost Effective, Large Screen LCD and CRT TVs
- Portable / Handheld LCD TVs
- Small Screen Video Displays

#### FEATURES

- Faroudja® DCDi – Edge™
- Integrated Triple ADC
- Digital Input Port
- Scaling Engine
- Image Enhancement
- Digital Output
- Interlaced and Progressive Scan Input/Output
- OSD Controller
- Embedded Microprocessor
- VBI Slicer
- JTAG Support

#### PACKAGE

- 208 PQFP

#### DESCRIPTION

The FLI8125 is a highly-integrated cost-effective mixed signal solution for LCD and CRT TV and Digital Video applications. Capable of meeting global broadcast market requirements, the FLI8125 incorporates a multi-standard video decoder, high-speed triple 8-bit Analog-to-Digital Converter (ADC), and front end switching. The integrated VBI Slicer adds Closed Captioning (CC) and Teletext service support, and the integrated microprocessor enables full system control without external devices.

The FLI8125 can capture and process both video and RGB graphics streams. The multi-standard video decoder is capable of accepting NTSC, PAL or SECAM and other sub-formats. The integrated ADC accepts both analog RGB and YPrPb inputs.

Interlaced video signals are converted into progressive scan signals using a memory-less deinterlacing technique. Progressive scan signals are then passed to the Faroudja® DCDi–Edge™ suite for further image processing. Faroudja® DCDi–Edge™ incorporates Faroudja’s patented and Emmy award winning Edge Correction technology eliminating objectionable staircasing on diagonal lines; Horizontal Enhancement technology is used to make an image look crisper and more realistic; Adaptive Contrast and Color (ACC) enables dynamic contrast enhancement and color saturation correction; and Active Color Management-II (ACM-II) enables color correction for subtle changes in color that can dramatically improve the image (e.g. flesh tone, green stretch, etc.). A fully programmable 3x3 matrix provides color space conversion and global color correction technology. Programmable Color Look Up Tables (CLUT) provides gamma correction of the output signal. Combined, these features facilitate accurate color reproduction that enables use of the full dynamic range on any fixed pixel display device.

#### FLI8125 SYSTEM DIAGRAM (“SMART” VIDEO DISPLAY)

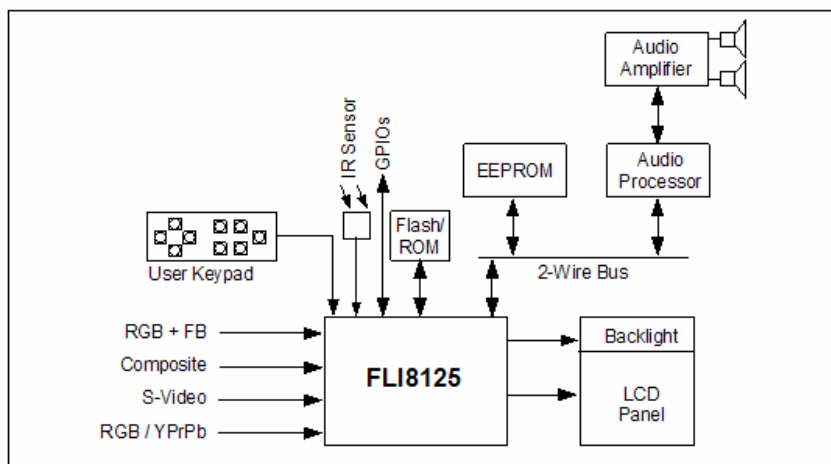

**FAROUDJA**

DCDi

EDGE™

## FLI8125 FUNCTIONAL BLOCK DIAGRAM

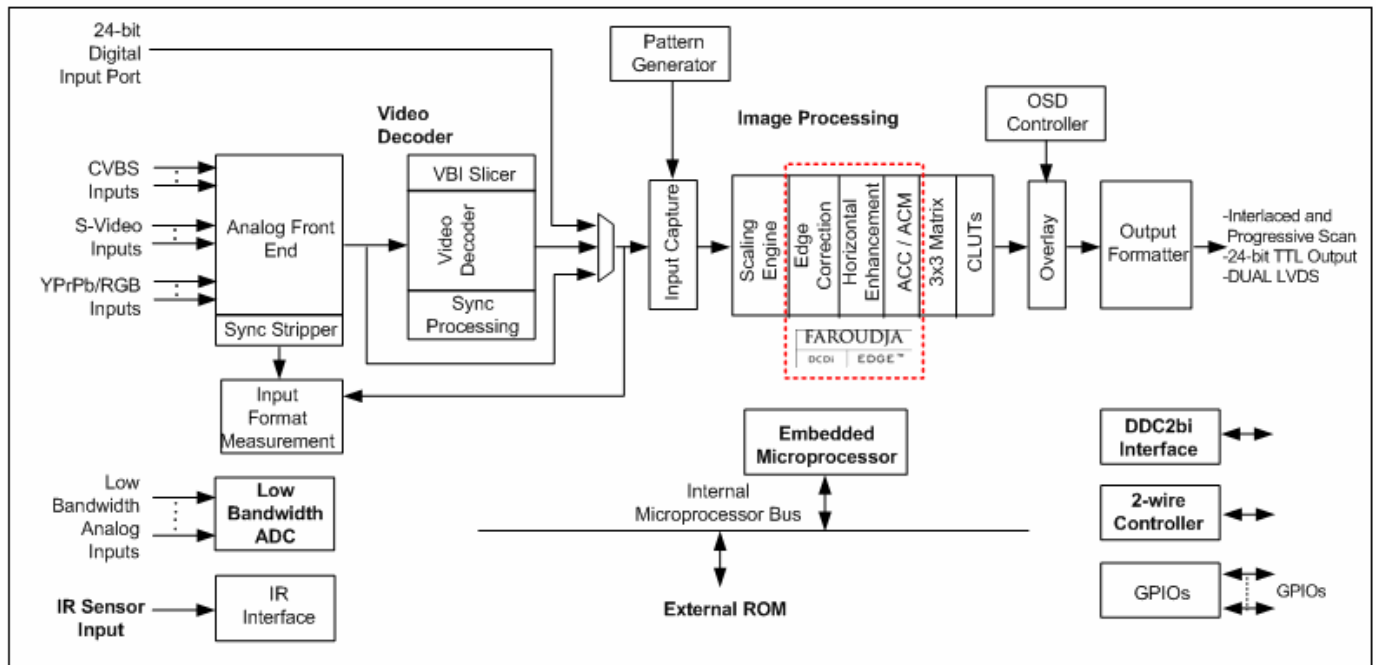

## FEATURE ATTRIBUTES

### INTEGRATED TRIPLE ADC

- RGB/YPrPb support up to 135MHz
- SCART-RGB + Fast Blank support
- Interlaced and progressive scan
- External OSD support

### DIGITAL INPUT PORT

- 24-bit re-configurable input port

### INTEGRATED 2D VIDEO DECODER

- Worldwide NTSC/PAL/SECAM support
- Macrovision™<sup>(1)</sup> and VCR trick mode support

### EMBEDDED MICROPROCESSOR

- Turbo 186 core
- Internal RAM/ROM
- Serial Flash/Parallel ROM support
- 2-wire slave controller, UART support
- Internal RESET Controller
- GPIOs, Low Bandwidth ADC-6 input
- Infrared Interface

### SCALING ENGINE

- Independent H & V scaling factors
- 4:2:2 YPrPb or 4:4:4 RGB scaling
- Anamorphic scaling (non-linear)

### FAROUDJA DCDI – EDGE™

- Edge Correction
  - Eliminates objectionable stair-casing
  - Enhances clarity and realism
- Horizontal Enhancement
- Adaptive Contrast and Color (ACC)
- Active Color Management-II (ACM-II)

### DIGITAL OUTPUT

- 18/24-bit 85MHz TTL output
- Dual LVDS up to SXGA
- Energy Spectrum Management for reducing EMI
- Programmable CLUT for gamma correction
- Interlaced and progressive scan **output**

### OSD CONTROLLER

- Up to 4 windows: 1, 2, or 4-bits per pixel color
- Programmable Font scalar to meet Teletext requirements

### VBI SLICER

- V-Chip, Closed Captioning, XDS, CGMS, WSS decode
- Teletext 1.5 support

### JTAG SUPPORT

- Boundary Scan support

<sup>1</sup> Macrovision is a trademark of Macrovision Corporation