

FAN8038 (KA3038)

4-Channel Motor Drive IC

Features

- 4-CH H-bridge driver
- Built-in DC/DC converter controller circuit
- Built-in reset circuit
- Built-in battery charging circuit
- Built-in voltage drop detector
- Built-in thermal shutdown circuit
- Built-in general op-amp
- Low power consumption
- Built-in power controller circuit

Description

FAN8038 is monolithic IC for portable CD player.

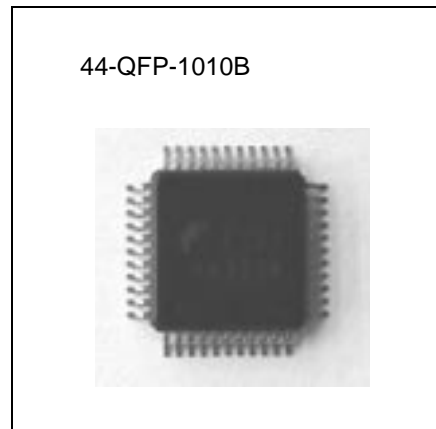

Typical application

- Portable compact disk player (CDP)
- Portable Mini disk player (MD)
- Disc-man
- Other portable compact disk media

Ordering Information

Device	Package	Operating Temp.
FAN8038	44-QFP-1010B	-35°C ~ +85°C

Pin Assignments

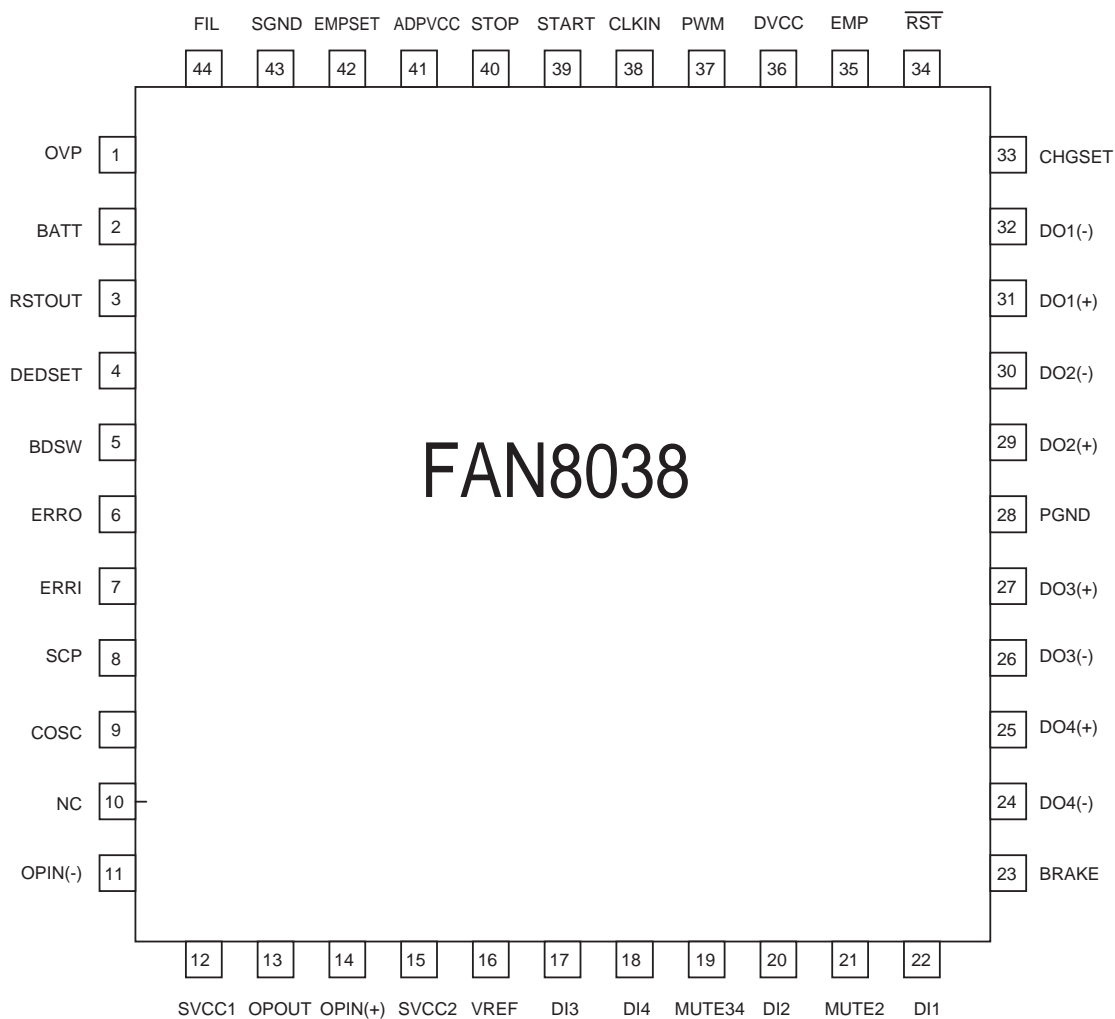

Pin Definitions

Pin Number	Pin Name	Pin Function Description
1	OVP	Battery power supply mode
2	BATT	Battery power supply
3	RSTOUT	RSTOUT detection output
4	DEDSET	DEDSET time setting
5	BDSW	Booster transistor drive
6	ERRO	Error amp output
7	ERRI	Error amp input
8	SCP	Short circuit protection setting
9	COSC	Triangular wave output
10	N.C	No connection
11	OPIN(-)	Op-amp negative input
12	SVCC1	control circuit power supply
13	OPOUT	Op-amp output
14	OPIN(+)	Op-amp positive input
15	SVCC2	Pre-drive power supply
16	VREF	Reference voltage
17	DI3	CH3 control signal input
18	DI4	CH4 control signal input
19	MUTE34	CH3, 4 mute
20	DI2	CH2 control signal input
21	MUTE2	CH2 mute
22	DI1	CH1 control signal input
23	BRAKE	CH1 Brake
24	DO4(-)	CH4 negative output
25	DO4(+)	CH4 positive output
26	DO3(-)	CH3 negative output
27	DO3(+)	CH3 positive output
28	PGND	Power unit power ground
29	DO2(+)	CH2 positive output
30	DO2(-)	CH2 negative output
31	DO1(+)	CH1 positive output
32	DO1(-)	CH1 negative output
33	CHGSET	Charge current setting
34	RST	RSTOUT inverting output
35	EMP	Empty detection output
36	DVCC	H-bridge power supply
37	PWM	PWM transistor drive
38	CLKIN	External clock input
39	START	Boost DC/DC converter starting
40	STOP	Boost DC/DC converter off
41	ADPVCC	Charging circuit power supply
42	EMPSET	Empty dection level converting
43	SGND	Signal ground
44	FIL	PWM phase compensation

Internal Block Diagram

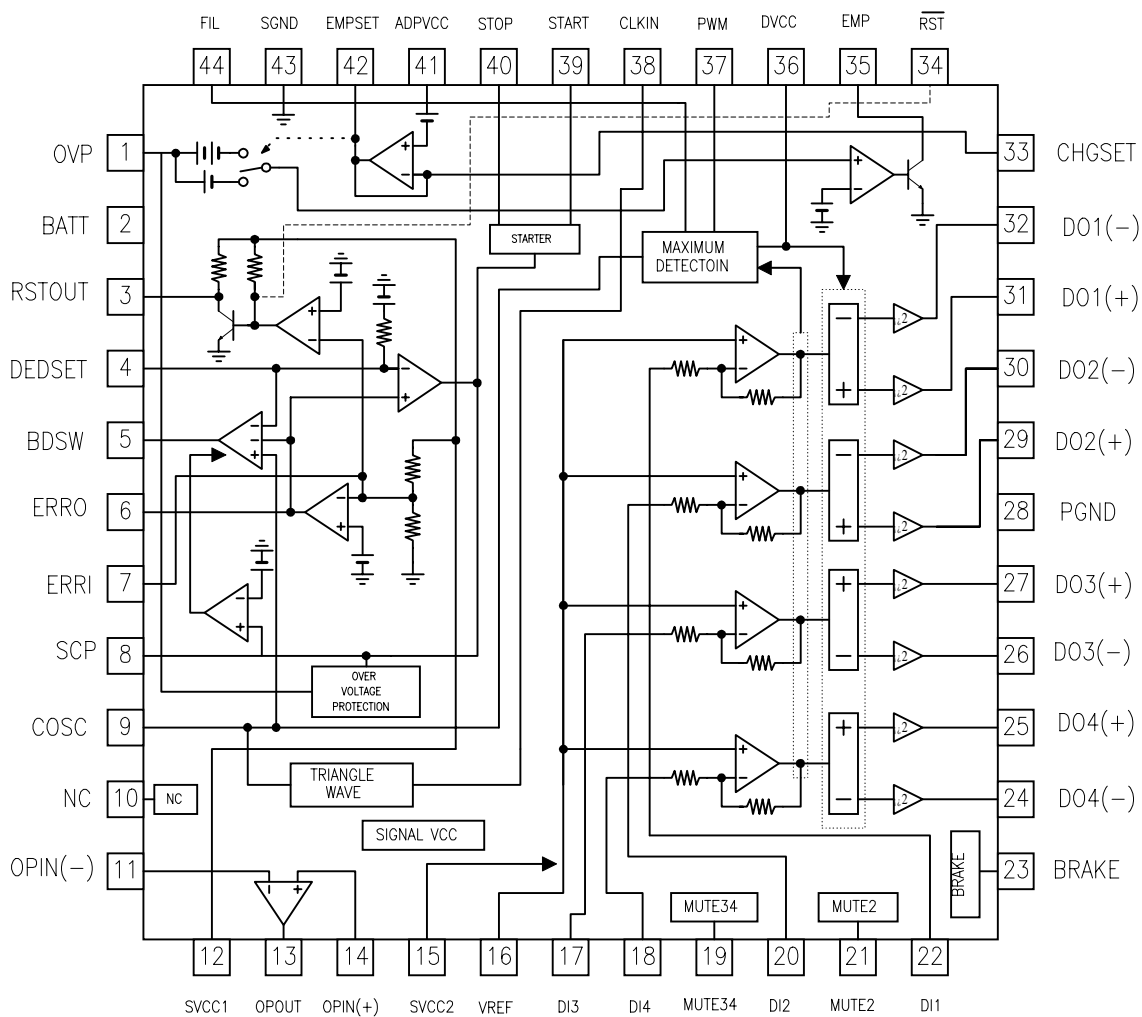

Absolute Maximum Ratings (Ta = 25°C)

Parameter	Symbol	Value	Unit
Maximum supply voltage	V _{CC}	13.2	V
Maximum output current	I _O	500	mA
Power dissipation	P _D	1.0	W
Operating temperature	T _{OPR}	-35 ~ +85	°C
Storage temperature	T _{STG}	-55 ~ +150	°C

Recommended Operating Conditions (Ta = 25°C)

Parameter	Symbol	Min.	Typ.	Max.	Unit
Charging circuit power supply voltage	ADPV _{CC}	3.0	4.5	8.0	V
Power Supply Voltage	BATT	1.5	2.4	8.0	V
Control Circuit Power Supply voltage	SV _{CC}	2.7	3.2	5.5	V
PRE-DRIVER V _{CC}	SV _{CC2}	2.7	3.2	5.5	V
Output Voltage	V _M	-	PWM	BATT	V
Operating Temperature	T _a	-10	25	70	°C

Electrical characteristics

(Ta=25°C, BATT=2.4V, SVCC1=SVCC2=3.2V, VREF=1.6V, ADPVCC=0V, fCLKIN=88.2KHz)

Parameter	Symbol	Conditions	Min.	Typ.	Max.	Units
COMMON SECTION						
BATT stand-by current	IST	BATT=10.5V, SVCC1,2=VREF=0V	-	-	5	μA
BATT supply current (No load)	IBATT	DVCC=0.45V, MUTE34=3.2V	-	2.5	3.5	mA
SVCC supply current (NO load)	ISVCC1	DVCC=0.45V, MUTE34=3.2V, ERRI=0V	-	3.0	3.5	mA
SVCC2 supply current (No load)	ISVCC2	DVCC=0.45V, MUTE34=3.2V	-	3.5	5.0	mA
ADPVCC supply current (No load)	IADPVCC	ADPVCC=4.5V, ROUT=OPEN	-	0.2	1.0	mA
H-DRIVE PART						
Voltage gain CH1, 3, 4 CH2	GVC134 GVC2	-	12 21.5	14 23.5	16 24.5	dB
Gain error by polarity	ΔGVC	-	-2	0	2	dB
Input pin resistance CH1, 3, 4 CH2	RD1134 RD12	IN=1.7 & 1.8V	9 6	11 7.5	13 9	KΩ
Maximum output voltage	VOUT	RL=8Ω, DVCC=BATT=4V, IN=0 ~ 3.2V	1.9	2.1	-	V
Saturation voltage (Lower)	VSAT1	IO=-300mA, IN=0 & 3.2V	-	240	400	mV
Saturation voltage (Upper)	VSAT2	IO=300mA, IN=0 & 3.2V	-	240	400	mV
Input offset voltage	VIO	-	-8	0	8	mV
Output offset voltage CH1, 3, 4 CH2	VOO134 VOO2	VREF=IN=1.6V	-70 -130	0 0	70 130	mV
DEAD zone	VDB	-	-30	0	30	mV
Brake1 on voltage	VM1ON	DI1=1.8V	2.0	-	-	V
Brake1 off voltage	VM1OFF	DI1=1.8V	-	-	0.8	V
MUTE2 on voltage	VM2ON	DI2=1.8V	2.0	-	-	V
MUTE2 off voltage	VM2OFF	DI2=1.8V	-	-	0.8	V
MUTE34 on voltage	VM34ON	DI3=DI4=1.8V	-	-	0.8	V
MUTE34 off voltage	VM34OFF	DI3=DI4=1.8V	2.0	-	-	V
VREF on voltage	VREFON	INn=1.8V(N=1, 2, 3, 4)	1.2	-	-	V
VREF off voltage	VREFOFF	INn=1.8V(N=1, 2, 3, 4)	-	-	0.8	V
BRAKE1 brake current	IBRAKE	brake current	4	7	10	mA

Electrical Characteristics (Continued)

Parameter	Symbol	Conditions	Min.	Typ.	Max.	Units
PWM POWER SUPPLY DRIVING						
PWM sink current	IPWM	DI1=2.1V	10	13	17	mA
DVCC level shift voltage	VSHIF	DI1=1.8V, DVCC-OUT1F	0.35	0.45	0.55	V
DVCC leak current	IDLK	DVCC=9V, SVCC1,2=BATT=0V	-	0	5	μA
PWM amp transfer gain	GPWM	DI1=1.8V, DVCC=1.2V ~ 1.4V	1/60	1/50	1/40	1/KΩ
DC/DC CONVERTER						
ERROR AMP						
SVCC1 pin threshold voltage	VS1TH	-	3.05	3.20	3.35	V
ERRO pin output voltage H	VEOH	ERRI=0.7V, IO=-100μA	1.4	1.6	-	V
ERRO pin output voltage L	VEOL	ERRI=1.3V, IO=100μA	-	-	0.3	V
SHORT CIRCUIT PROTECTION						
SCP pin voltage	VSCP	ERRI=1.3V	-	0	0.1	V
SCP pin current 1	ISCP1	ERRI=0.7V	6	10	16	μA
SCP pin current 2	ISCP2	ERRI=1.3V, OFF=0V	12	20	32	μA
SCP pin current 3	ISCP3	ERRI=1.3V, BATT=9.5V	12	20	32	μA
SCP pin impedance	RSCP	-	175	220	265	KΩ
SCP pin threshold voltage	VSCPTH	ERRI=0.7V, COSC=470PF	1.10	1.20	1.30	V
Over-voltage protection detect	VOVP	OVP Voltage	9.5	10	10.5	V
TRANSISTOR DRIVING						
BDSW pin output voltage 1H	VSW1H	BATT=COSC=1.5V =SVCC2=0V, 10mA	0.78	0.98	1.13	V
BDSW pin output voltage 2H	VSW2H	COSC=0V, IO=-10mA, ERRI=0.7V SCP=0V	1.0	1.5	-	V
BDSW pin output voltage 2L	VSW2L	CT=2V, IO=1-mA	-	0.3	0.45	V
BDSW pin oscillating reequency 1	fsw1	COSC=470pF, =SVCC2=0V	65	80	95	KHz
SW pin oscillating reequency 2	fsw2	COSC=470pF, CLKIN=0V	60	70	82	KHz
BDSW pin oscillating reequency 3	fsw3	COSC=470pF	-	88.2	-	KHz
BDSW pin minimum pulse width	TSWMIN	COSC=470pF, ERRO=0.5 → 0.7V	0.01	-	0.6	μs
Pulse duty start	DSW1	COSC=470PF, SVSS1,SVCC2=0V	40	50	60	%
MAX. pulse duty at self-running	DSW2	COSC=470pF, ERRO=0.8V, CLKIN=0V	50	60	70	%
MAX. pulse duty at CLKIN synchronization	DSW3	ERRO=0.8V, COSC=470pF	45	55	65	%

Electrical Characteristics (Continued)

Parameter	Symbol	Conditions	Min.	Typ.	Max.	Units
DEAD TIME						
DEASET pin impedance	RDEASET	-	52	65	78	K Ω
DEASET pin output voltage	VDEASET	-	0.78	0.88	0.98	V
INTERFACE						
STOP pin threshold voltage	VSTOPH	ERRI=1.3V	2.0	-	-	V
STOP pin bias current	ISTOP	OFF=0V	75	95	115	μ A
START pin on threshold voltage	VSTATH1	SVCC1,SVCC2=0V, COSC=2V	1.3	-	-	V
START pin off threshold voltage	VSTATH2	SVCC1,SVCC2=0V, COSC=2V	-	-	2.1	V
START pin bias current	ISTART	START=0V	13	16	19	μ A
CLKIN pin threshold voltage H	VCLKINTH H	-	2.0	-	-	V
CLKIN pin threshold voltage L	VCLKINTH L	-	-	-	0.8	V
CLKIN pin bias current	ICLKIN	CLKIN=3.2V	-	-	10	μ A
START CURCUIT						
Starter switching voltage	VSSV	SVCC1,SVCC2=0V \rightarrow 3.2V START=0V	2.3	2.5	2.7	V
Starter switching hysteresis width	VSSHS	START=0V	130	200	300	mV
Discharge release voltage	VDIS	-	1.63	1.83	2.03	V
RESET CIRCUIT						
SVCC1 RESET threshold voltage ratio	RRSTOTH	-	85	90	95	%
RESET detection hysteresis width	VRSTHS	-	25	50	100	mV
RSTOUT pin output voltage	VRSTO	IO=1mA, SVCC1,SVCC2=2.8V	-	-	0.5	V
RSTOUT pin pull up resistance	RRSTO	-	72	90	108	K Ω
RST pin output voltage 1	VRST1	IO=-1mA, SVCC1,SVCC2=2.8V	2.0	-	2.4	V
RST pin output voltage 2	VRST2	IO=-1mA, SVCC1,SVCC2=0V	2.0	-	2.4	V
RST pin pull up resistance	RRST	-	77	95	113	K Ω

Electrical Characteristics (Continued)

Parameter	Symbol	Conditions	Min.	Typ.	Max.	Units
OP-AMP						
Input bias current	IBIAS	IN(+)=1.6V	-	-	300	nA
Input offset voltage	VOFOP	IN(+)=1.6V	-5.5	0	5.5	mV
High level output voltage	VOHOP	RL=OPEN	2.8	-	-	V
Low level output voltage	VOLOP	RL=OPEN	-	-	0.2	V
Output drive current (Source)	VSOURCE	50Ω GND	-	-6.5	-3.0	mA
Output drive current (Sink)	VSINK	50Ω SVCC	0.4	0.7	-	mA
Open loop voltage gain	GVO	VIN=-75dB, F=1KHz	-	70	-	dB
Slew rate	SR	-	-	0.5	-	V/μs
BATTERY CHARGING CURCUIT						
CHGSET pin bias voltage	VCHGSET	ADPVCC=4.5V, CHGSET=1.8KΩ	0.71	0.81	0.91	V
CHGSET pin output resistance	RCHGSET	ADPVCC=4.5V	0.75	0.95	1.20	KΩ
EMPSET pin leak current 1	IEMPSET	ADPVCC=4.5V, CHGSET=OPEN	-	-	1.0	μA
EMPSET pin leak current 2	IEMPSET	ADPVCC=0.6V, CHGSET=1.8KΩ	-	-	1.0	μA
EMPSET pin saturation voltage	VEMPSET	ADPVCC=4.5V, IO=300mA, CHGSET=0Ω	-	0.45	1.0	V
EMPTY DETECTION						
EMP detection voltage 1	VEMPT1	VEMPSET=0V	2.1	2.2	2.3	V
EMP detection voltage 2	VEMPT2	IEMPSET=-2μA	1.7	1.8	1.9	V
EMP detection hysteresis voltage 1	VEMHS1	VEMPSET=0V	25	50	100	mV
EMP detection hysteresis voltage 2	VEMHS2	IEMPSET=-2μA	25	50	100	mV
EMP pin output voltage	VEMP	IO=1mA, OVP=1V	-	-	0.5	V
EMP pin output leak current	IEMPLK	OVP=2.4V	-	-	1.0	μA
OVP pin input resistance	ROVP	VEMPSET=0V	17	23	27	KΩ
OVP pin leak current	IOVPLK	SVCC1=SVCC2=0V, OVP=4.5V	-	-	1.0	V
EMP_SET pin detection voltage	VEMPSET	VEMPSET=BATT-EMPSET, OVP=2V	1.5	-	-	V
EMP_SET pin detection current	IEMPSET	EMPSET	-2	-	-	μA

Application Information

1. MUTE FUNCTION

- When The BRAKE Pin is low is normal opration (high is CH1 mute on).
- When The Mute2 Pin is low is normal opration (high is CH2 mute on).
- When The Mute34 Pin is high is normal opration (low is CH3,4 mute on).

2. VREF DROP MUTE (FIGURE 1)

- When the Voltage of the mute pin is above 1V, the mute circuit is stopped and the output circuit is.

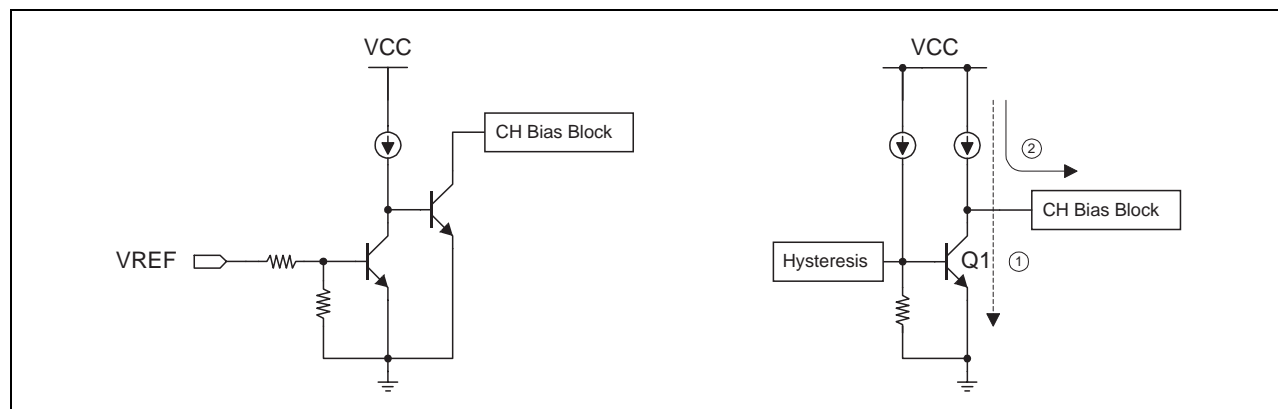

Figure 1. VREF Drop MUTE Circuit

Figure 2. TSD Circuit

3. THERMAL SHUTDOWN(FIGURE 2)

- If the chip temperature rises above 150°C, then the thermal shutdown (TSD) circuit is activated and the output circuit will be mute.

4. H-BRIDGE DRIVER (4-CHANNELS)

Driver input resistance is 10KΩ of CH1, CH3, CH4 and input resistance of CH2 is 7.5KΩ.

Driver gain can obtain under -mentioned

$$\text{CH1, 3, 4: } GV = 20\log \left| \frac{55K}{11K + R} \right|$$

$$\text{CH2 } GV = 20\log \left| \frac{110K}{7.5K + R} \right|$$

R is External resistance.

5. SWITCHING REGULATED POWER SUPPLY DRIVE

- This circuit detects a maximum output value of 4CH drivers and then generates PWM Signal.
- External Component is PNP-Tr, Coil, Schottky Diode and Capacitor .

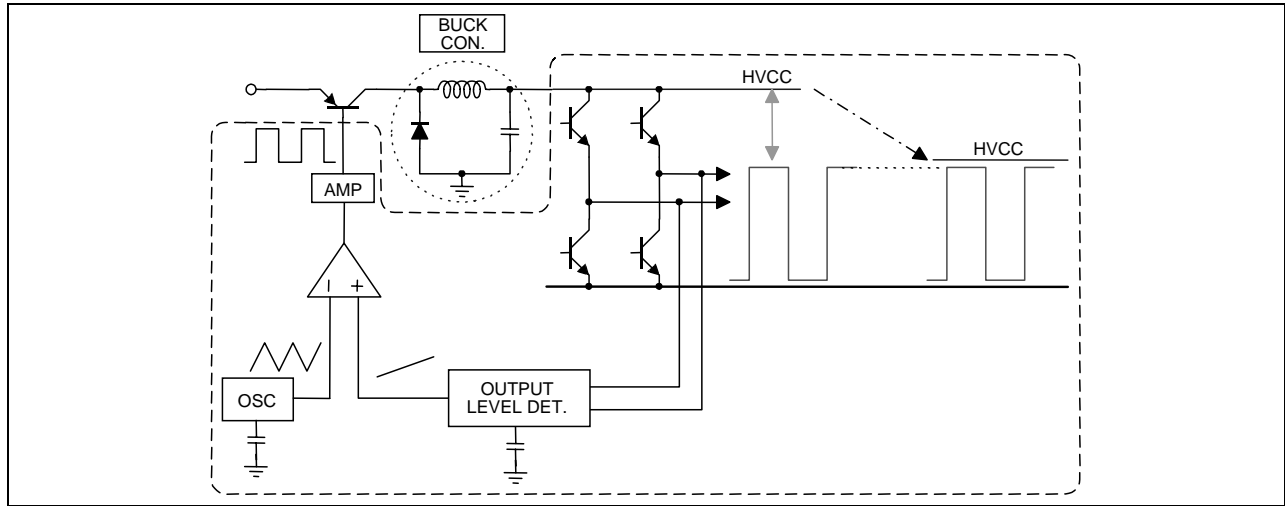

Figure 1. Switching Regulated Power Supply

6. DC/DC CONVERTER CONTROL CIRCUIT

- Booster circuit needs External component. and the voltage() is defined as follows.

$$SVCC1 = 1.267 \times \frac{R1 \cdot R3 + R2 \cdot R4}{R1 + R3} \cdot \frac{R2 \cdot R4}{R2 + R4}$$

R1 = Resistor1
 R2 = Resistor2
 R3 = 30KΩ
 R4 = 30.5KΩ

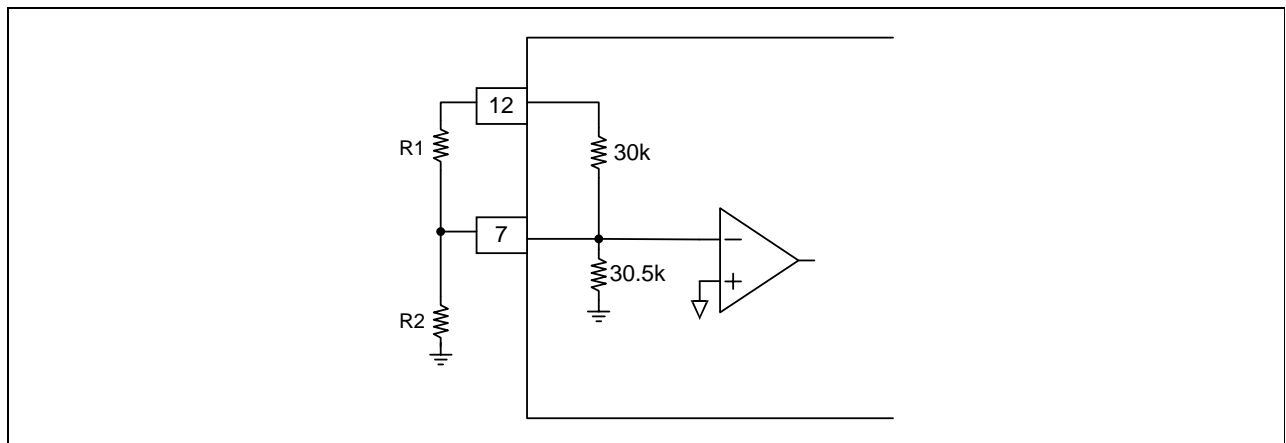

Figure 2. Output Voltage

- Short Circuit Protection function when GND and is short, ERRI become LOW and ERRO HIGH and it makes capacitor charging. fanally AMP3 is OFF.(figure 5)

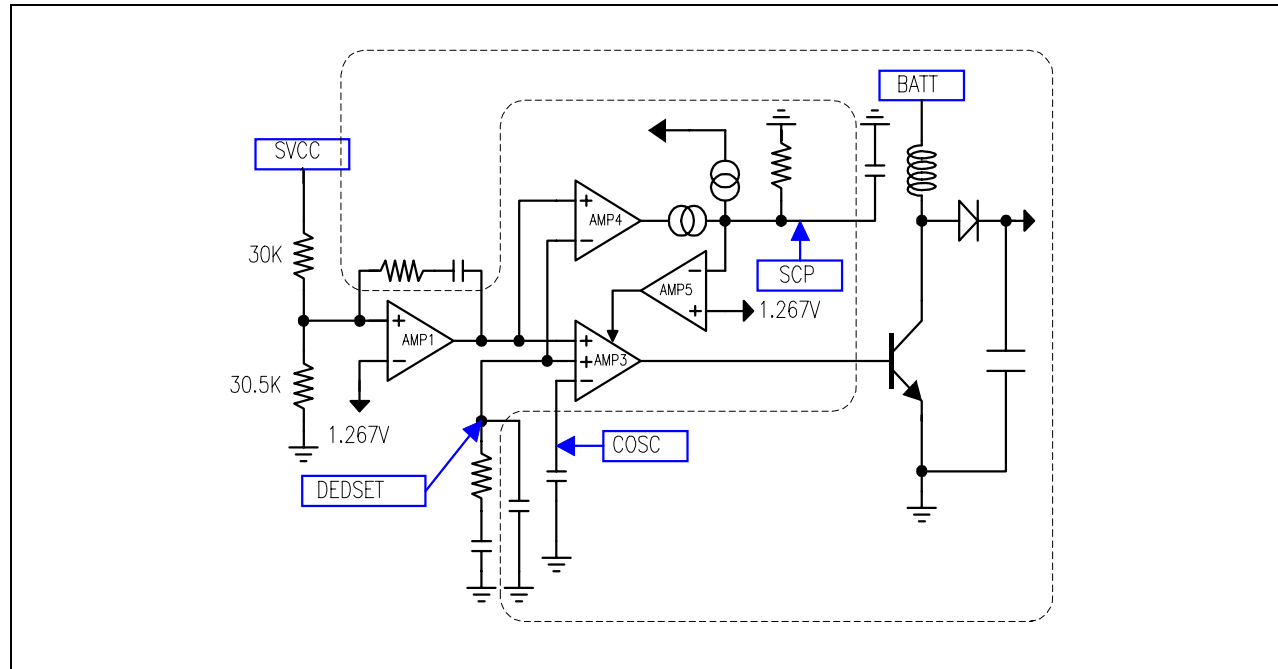

Figure 3. DC/DC Converter Control Circuit

Switching off time depend on a capacitor of the SCP. and the equation is as follow.

$$t = C_{SCP} \times \frac{V_{TH}}{I_{SCP}} \quad (V_{TH} = 1.25V, I_{SPRT} = 10\mu A)$$

- Max Duty can be controlled resistor. the equation is as follow.

$$t = C_{DESET} \times R \quad (R = 65K\Omega)$$

- Capacitor of the SCP terminal can control disable switching time and it can be calculated by as follow equation.

$$t = C_{SCP} \times \frac{V_{TH}}{I_{STOP}} \quad (V_{TH} = 1.25V, I_{OFF} = 20\mu A)$$

- Over Voltage Protection BATT Voltage is over 9.7V charging SCP terminal Capacitor, it reach to V_{TH} SW terminal signal is OFF the equation is as follow

$$t = C_{SCP} \times \frac{V_{TH}}{I_{HV}} \quad (V_{TH} = 1.25V, I_{HV} = 20\mu A)$$

- If Output Voltage of RSTOUT Circuit DC/DC Converter is over than 90%, RSTOUT terminal turn to HIGH and Hysteresis is 50mV. and RSTOUT state is ON.

7. EMPTY DETECTING CIRCUIT.

EMPSET	Detect Voltage	Hysteresis	Mode
LOW	2.2V	50mV	Battery Mode
HIGH-Z	1.8V	50mV	Adapter Mode

8. BATTERY CHARGING CIRCUIT

- the battery charger circuit is separated from any other block .
- TSD operate at 150°C. Hysteresis is 30°C

Typical Performance Characteristics

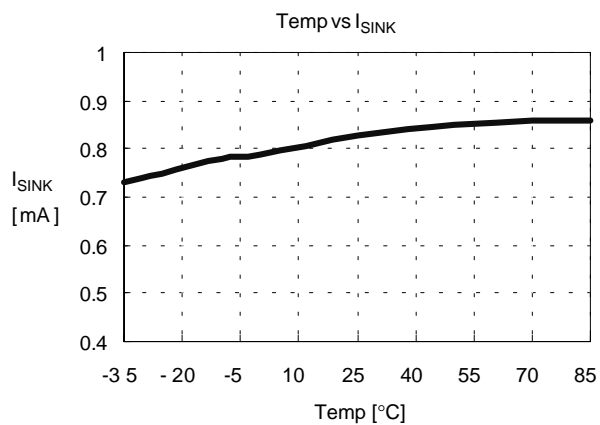
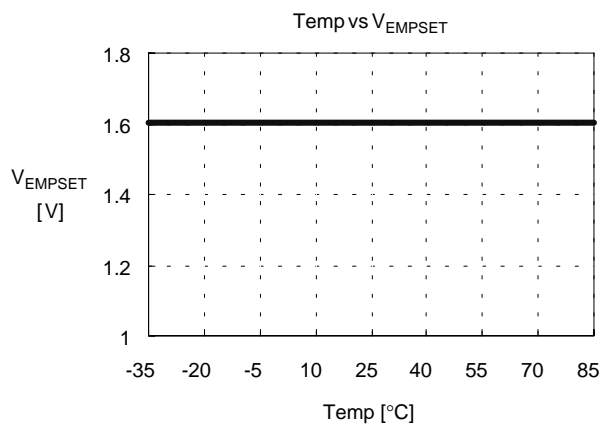
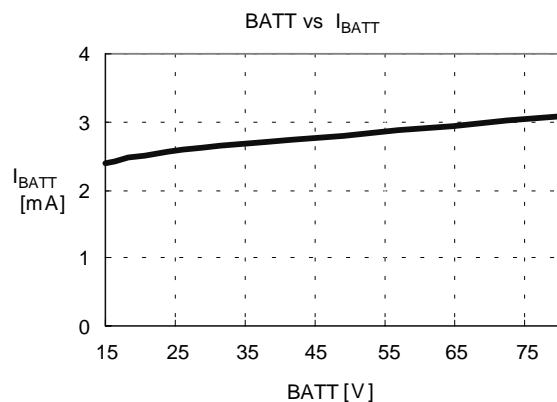
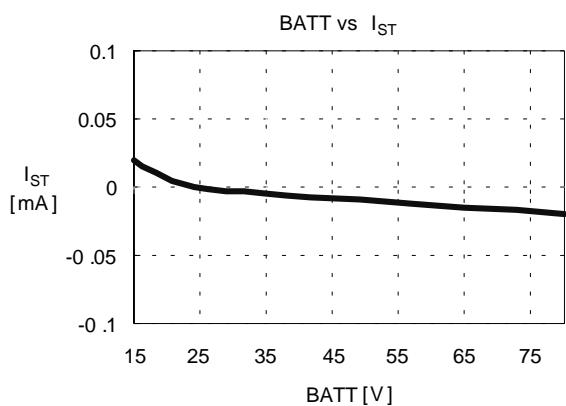
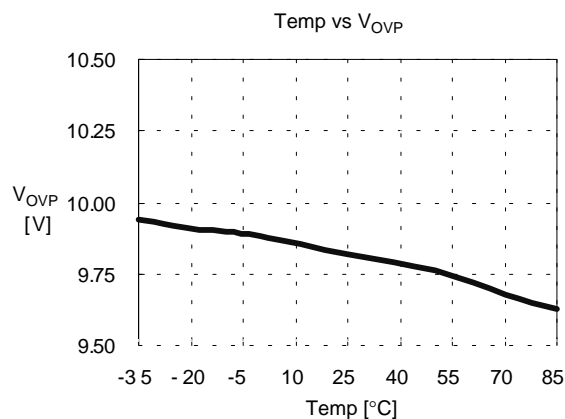
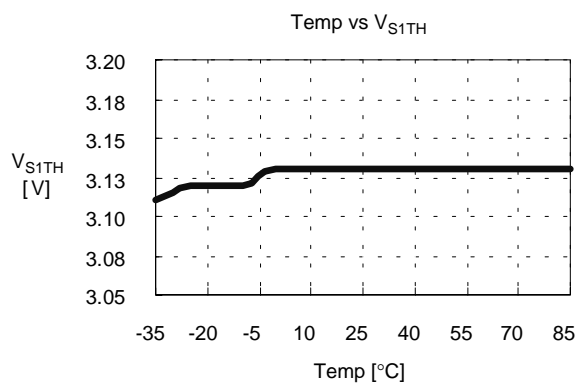

Application Circuits

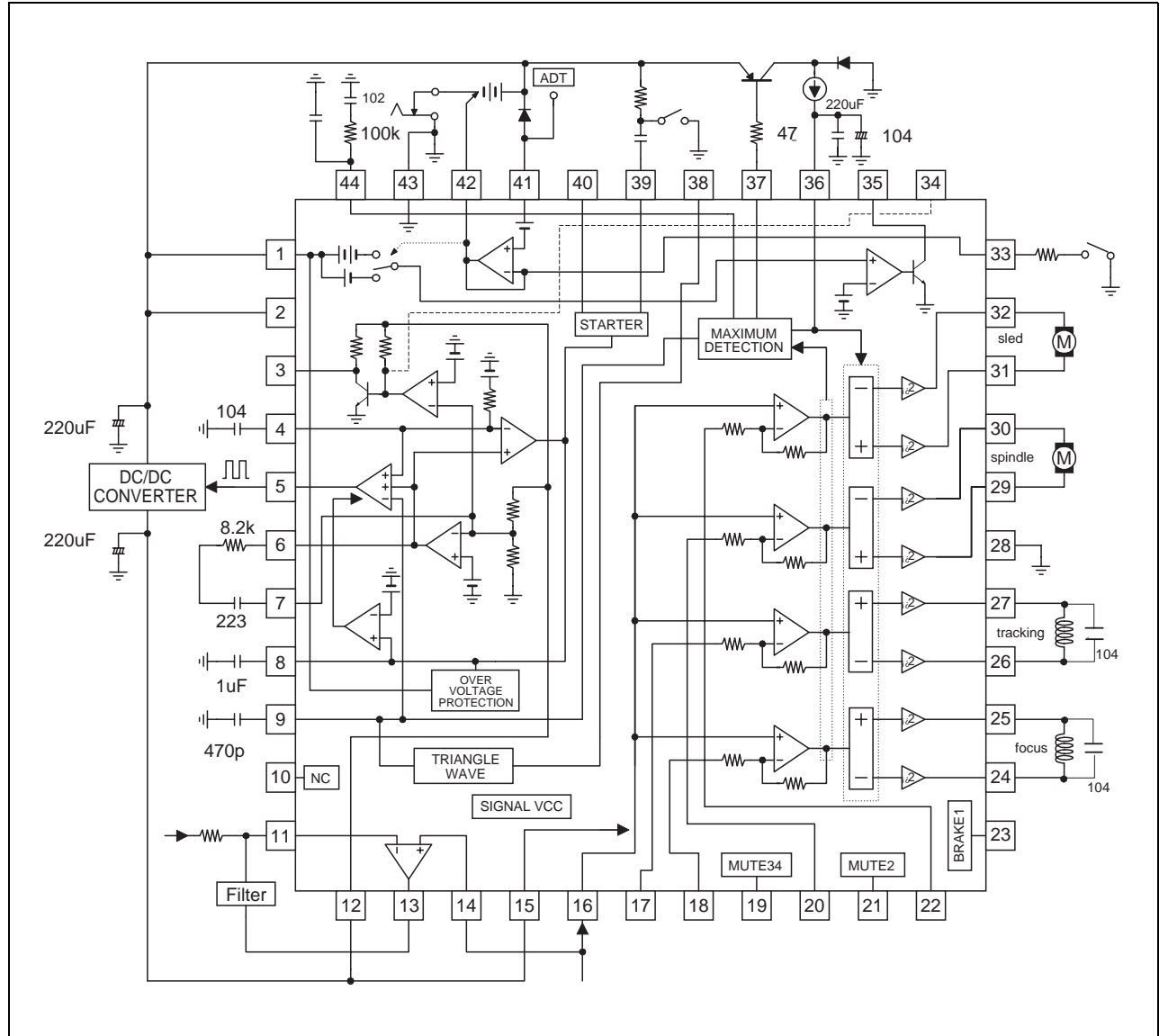

TRADEMARKS

The following are registered and unregistered trademarks Fairchild Semiconductor owns or is authorized to use and is not intended to be an exhaustive list of all such trademarks.

ACE ^x [™]	FAST ^r [™]	QFET [™]	VCX [™]
Bottomless [™]	GlobalOptoisolator [™]	QS [™]	
CoolFET [™]	GTO [™]	QT Optoelectronics [™]	
CROSSVOLT [™]	HiSeC [™]	Quiet Series [™]	
DOME [™]	ISOPLANAR [™]	SuperSOT [™] -3	
E ² CMOS [™]	MICROWIRE [™]	SuperSOT [™] -6	
EnSigna [™]	OPTOLOGIC [™]	SuperSOT [™] -8	
FACT [™]	OPTOPLANAR [™]	SyncFET [™]	
FACT Quiet Series [™]	POP [™]	TinyLogic [™]	
FAST [®]	PowerTrench [®]	UHC [™]	

DISCLAIMER

FAIRCHILD SEMICONDUCTOR RESERVES THE RIGHT TO MAKE CHANGES WITHOUT FURTHER NOTICE TO ANY PRODUCTS HEREIN TO IMPROVE RELIABILITY, FUNCTION OR DESIGN. FAIRCHILD DOES NOT ASSUME ANY LIABILITY ARISING OUT OF THE APPLICATION OR USE OF ANY PRODUCT OR CIRCUIT DESCRIBED HEREIN; NEITHER DOES IT CONVEY ANY LICENSE UNDER ITS PATENT RIGHTS, NOR THE RIGHTS OF OTHERS.

LIFE SUPPORT POLICY

FAIRCHILD'S PRODUCTS ARE NOT AUTHORIZED FOR USE AS CRITICAL COMPONENTS IN LIFE SUPPORT DEVICES OR SYSTEMS WITHOUT THE EXPRESS WRITTEN APPROVAL OF FAIRCHILD SEMICONDUCTOR CORPORATION. As used herein:

1. Life support devices or systems are devices or systems which, (a) are intended for surgical implant into the body, or (b) support or sustain life, or (c) whose failure to perform when properly used in accordance with instructions for use provided in the labeling, can be reasonably expected to result in significant injury to the user.
2. A critical component is any component of a life support device or system whose failure to perform can be reasonably expected to cause the failure of the life support device or system, or to affect its safety or effectiveness.

PRODUCT STATUS DEFINITIONS

Definition of Terms

Datasheet Identification	Product Status	Definition
Advance Information	Formative or In Design	This datasheet contains the design specifications for product development. Specifications may change in any manner without notice.
Preliminary	First Production	This datasheet contains preliminary data, and supplementary data will be published at a later date. Fairchild Semiconductor reserves the right to make changes at any time without notice in order to improve design.
No Identification Needed	Full Production	This datasheet contains final specifications. Fairchild Semiconductor reserves the right to make changes at any time without notice in order to improve design.
Obsolete	Not In Production	This datasheet contains specifications on a product that has been discontinued by Fairchild semiconductor. The datasheet is printed for reference information only.