



FAH4830

Haptic Driver for DC Motors (ERMs) and Linear Resonant Actuators (LRAs)

Features

- Direct Drive of ERM and LRA Motors
- External PWM Input (10 kHz to 50 kHz)
- External Motor Enable/Disable Input
- Internal Mode-Select Register: ERM or LRA
- Low Standby Current: <500 nA
- Fast Wake-up Time
- Nearly Rail-to-Rail Output Swing
- Register-Based Control by I²C
- Over Driving Motor Control
- Under-Voltage, Over-Current, and Over-Temperature Protections
- Settable Filter and External Gain Control
- Package: 10-Lead MLP

Applications

- Mobile Phones
- Handheld Devices
- Any Key-Pad Interface

Related Resources

- [AN-5067 — PCB Land Pattern Design and Surface-Mount Guidelines for MLP Packages](#)

Description

The FAH4830 is a high-performance enhanced haptic drive for mobile phone and other hand-held devices. The haptic driver takes a single-ended PWM input signal to control a DC motor. It can drive both Eccentric Rotating Mass (ERM) and Linear Resonant Actuator (LRA) motors. The device utilizes an external 10 kHz to 50 kHz PWM signal capable of meeting the wide range of resonant frequencies.

The FAH4830 has its own register maps accessible via I²C serial communication. A gain control setting can be used to help prevent PWM noise from getting into the motor and to control the maximum output voltage on the motor. For ERM motors, the over-drive control block is designed to control the inertial momentum of the motor.

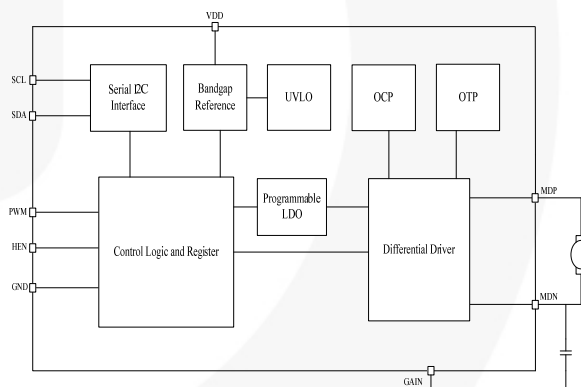

Figure 1. Block Diagram

Ordering Information

Part Number	Operating Temperature Range	Package	Packing Method
FAH4830MPX	-40°C to +85°C	10-Lead, Dual, JEDEC MO-229, 3mm Square, Molded Leadless Package (MLP)	3000 Units on Tape & Reel

Pin Configuration

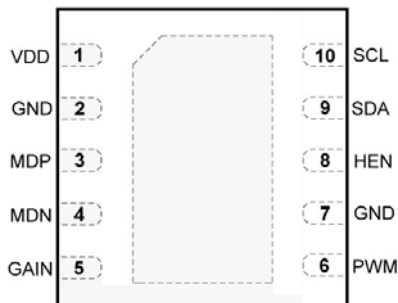

Figure 2. Pin Assignments (Top View)

Pin Definitions

Name	Pin #	Type	Description
VDD	1	Power	Power
GND	2, 7	Power	Ground
MDP	3	Output	Positive motor driver output
MDN	4	Output	Negative motor driver output
GAIN	5	Input	Gain control for motor driving (39 nF capacitor required to tied to MDN)
PWM	6	Input	PWM input
HEN	8	Input	Haptic motor enable/disable (HIGH: enable, LOW: disable)
SDA	9	Input	I ² C data input
SCL	10	Input	I ² C clock input

Note:

- The exposed DAP should be connected to ground.

Absolute Maximum Ratings

Stresses exceeding the absolute maximum ratings may damage the device. The device may not function or be operable above the recommended operating conditions and stressing the parts to these levels is not recommended. In addition, extended exposure to stresses above the recommended operating conditions may affect device reliability. The absolute maximum ratings are stress ratings only.

Symbol	Parameter	Min.	Max.	Unit
V _{DD}	DC Supply Voltage	-0.3	6.0	V
V _{IO}	Analog and Digital I/O (All Input and Output Pins)	-0.3	V _{CC} +0.3	V

Reliability Information

Symbol	Parameter	Min.	Typ.	Max.	Unit
T _J	Junction Temperature			+150	°C
T _{STG}	Storage Temperature Range	-65		+150	°C
Θ _{JA}	Thermal Resistance, JEDEC Standard, Multilayer Test Boards, Still Air		200		°C/W

Electrostatic Discharge Information

Symbol	Parameter	Max.	Unit
ESD	Human Body Model, JESD22-A114	8	kV
	Charged Device Model, JESD22-C101	2	

Recommended Operating Conditions

The Recommended Operating Conditions table defines the conditions for actual device operation. Recommended operating conditions are specified to ensure optimal performance to the datasheet specifications. Fairchild does not recommend exceeding them or designing to Absolute Maximum Ratings.

Symbol	Parameter	Min.	Typ.	Max.	Unit
T _A	Operating Temperature Range	-40		+85	°C
V _{DD}	Supply Voltage Range	2.7	3.3	5.5	V

Electrical Characteristics

Typical values are at $T_A = 25^\circ\text{C}$, $V_{DD} = 3.3\text{ V}$, and $V_{LDO} = 3.0\text{ V}$ unless otherwise noted.

Symbol	Parameter	Conditions	Min.	Typ.	Max.	Unit
I_{IQY}	PWM Input Frequency	Square Wave Input	10		50	kHz
$I_{IH_{PWM}}$	Input Current	$PWM = 3.3\text{ V}$		0.1	1.0	μA
$I_{IH_{HEN}}$	Input Current	$HEN = 3.3\text{ V}$		0.1	1.0	μA
$I_{IL_{PWM}}$	Input Current	$PWM = 0.0\text{ V}$		0.1	1.0	μA
$I_{IL_{HEN}}$	Input Current	$HEN = 0.0\text{ V}$		0.1	1.0	μA
$I_{IH_{SCL}}$	Input Current	$SCL = 3.3\text{ V}$		0.1	1.0	μA
$I_{IH_{SDA}}$	Input Current	$SDA = 3.3\text{ V}$		0.1	1.0	μA
$I_{IL_{SCL}}$	Input Current	$SCL = 0.0\text{ V}$		0.1	1.0	μA
$I_{IL_{SDA}}$	Input Current	$SDA = 0.0\text{ V}$		0.1	1.0	μA
V_{IH}	Input Logic high		$0.7 \times V_{DD}$			V
V_{IL}	Input Logic Low				$0.3 \times V_{DD}$	V
I_{CAP}	Input Capacitance	PWM Capacitance to GND or VDD		19		pF
V_{OL}	Output Voltage	$V_{DD} = 3.3\text{ V}$, $R_L = 10\ \Omega$		100	200	mV
V_{OH}	Output Voltage	$V_{DD} = 3.3\text{ V}$, $R_L = 10\ \Omega$	$V_{LDO}-0.3$	2.9	3.1	V
I_{OUT}	Short-Circuit Protection	$V_{DD} = 3.3\text{ V}$, MDP to MDN Short to Each Other & Short to GND		500		mA
t_{WU}	Wake-up Time			30	50	μs
t_{SD}	Shutdown Time	$PWM = 50\%$ Duty Cycle, $CF = 39.0\text{ nF}$, HEN HIGH to LOW		1	3	μs
R_{IN}	Input Resistance	Gain Input – Default Register Setting		10		k Ω
C_{IN}	Input Capacitance	Gain Input		10		pF
I_{DD}	Supply Current	$PWM = 22.4\text{ kHz}$ 50% Duty, LRA/ERM Mode, $R_L = 10\ \Omega$		4	7	mA
I_{PO}	Power-Down Supply Current	$V_{PWM} = 0\text{ V}$, $V_{DD} = 2.7\text{ V}$, $V_{LDO} = 2.4\text{ V}$, Reg 0x20 bit 7=0		100	400	nA
V_{OUT}	Output Voltage Range		2.4	3.0	3.6	V
V_{REG}	Output Voltage Accuracy		-1		1	%

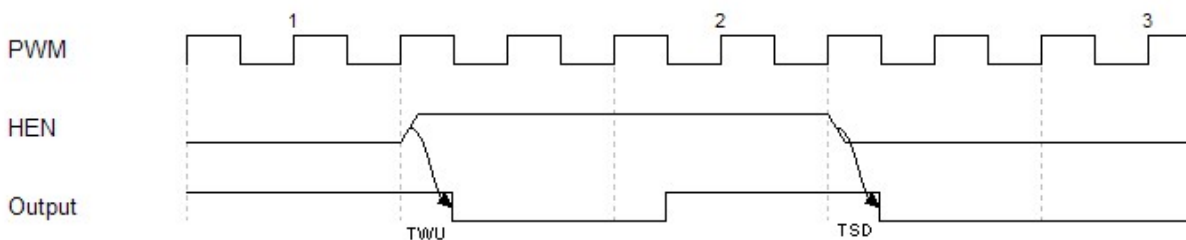

Figure 3. Haptic Enable/Disable Functional Timing

I²C DC Electrical Characteristics

T_A = 25°C, V_{DD} = 3.3 V, and V_{LDO} = 3.0 V unless otherwise noted.

Symbol	Parameter	Fast Mode (400kHz)		
		Min.	Max.	Unit
V _{IL}	Low-Level Input Voltage	-0.3	0.6	V
V _{IH}	High-Level Input Voltage	1.3		V
V _{OL}	Low-Level Output Voltage at 3 mA Sink Current (Open-Drain or Open-Collector)	0	0.4	V
I _{IH}	High-Level Input Current of Each I/O Pin, Input Voltage = V _{DD}	-1	1	μA
I _{IL}	Low-Level Input Current of Each I/O Pin, Input Voltage = 0 V	-1	1	μA

I²C AC Electrical Characteristics

Symbol	Parameter	Fast Mode (400kHz)		
		Min.	Max.	Unit
f _{SCL}	SCL Clock Frequency	0	400	kHz
t _{HD,STA}	Hold Time (Repeated) START Condition	0.6		μs
t _{LOW}	Low Period of SCL Clock	1.3		μs
t _{HIGH}	High Period of SCL Clock	0.6		μs
t _{SU,STA}	Set-up Time for Repeated START Condition	0.6		μs
t _{HD,DAT}	Data Hold Time	0	0.9	μs
t _{SU,DAT}	Data Set-up Time ⁽²⁾	100		ns
t _r	Rise Time of SDA and SCL Signals ⁽³⁾	20+0.1C _b	300	ns
t _f	Fall Time of SDA and SCL Signals ⁽³⁾	20+0.1C _b	300	ns
t _{SU,STO}	Set-up Time for STOP Condition	0.6		μs
t _{BUF}	Bus-Free Time between STOP and START Conditions	1.3		μs
t _{SP}	Pulse Width of Spikes that Must Be Suppressed by the Input Filter	0	50	ns

Notes:

- A Fast-Mode I²C Bus® device can be used in a Standard-Mode I²C bus system, but the requirement t_{SU,DAT} ≥ 250 ns must then be met. This is automatically the case if the device does not stretch the LOW period of the SCL signal. If such a device does stretch the LOW period of the SCL signal, it must output the next data bit to the Serial Data (SDA) line t_{r,max} + t_{SU,DAT} = 1000 + 250 = 1250 ns (according to the Standard-Mode I²C Bus specification) before the SCL line is released.
- C_b equals the total capacitance of one bus line in pf. If mixed with High-Speed Mode devices, faster fall times are allowed according to the I²C specification.

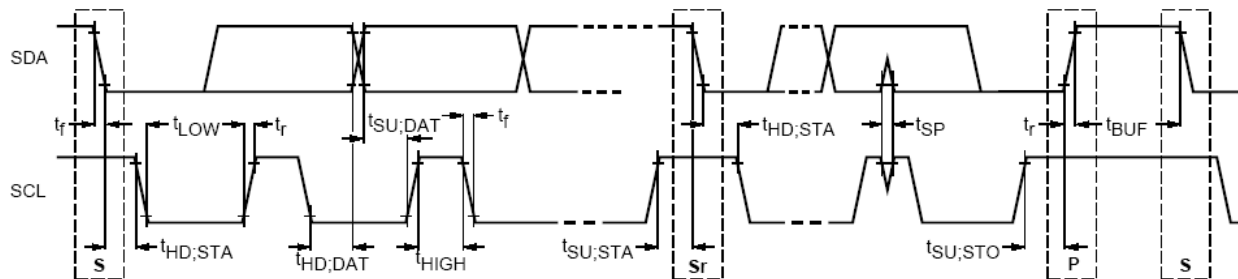

Figure 4. Definition of Timing for Full-Speed Mode Devices on the I²C Bus

Functional Description

I²C Control

Writing to and reading from registers is accomplished via the I²C interface. The I²C protocol requires that one device on the bus initiates and controls all read and write operations. This device is called the “master” device. The master device generates the SCL signal, which is the clock signal for all other devices on the bus. All other devices on the bus are called “slave” devices. The FAH4830 is a slave device. Both the master and slave devices can send and receive data on the bus.

During I²C operations, one data bit is transmitted per clock cycle. All I²C operations follow a repeating nine-clock-cycle pattern that consists of eight bits (one byte) of transmitted data followed by an acknowledge (ACK) or not acknowledge (NACK) from the receiving device. Note that there are no unused clock cycles during any operation; therefore, there must be no breaks in the stream of data and ACKs/NACKs during data transfers.

For most operations, I²C protocol requires the SDA line remain stable (unmoving) whenever SCL is HIGH. For example, transitions on the SDA line can only occur when SCL is LOW. The exceptions are when the master device issues a START or STOP condition. The slave device cannot issue a START or STOP condition.

START Condition: This condition occurs when the SDA line transitions from HIGH to LOW while SCL is HIGH. The master device uses this condition to indicate that a data transfer is about to begin.

STOP Condition: This condition occurs when the SDA line transitions from LOW to HIGH while SCL is HIGH. The master device uses this condition to signal the end of a data transfer.

Acknowledge and Not Acknowledge: When data is transferred to the slave device, the slave device sends acknowledge (ACK) after receiving every byte of data. The receiving device sends an ACK by pulling SDA LOW for one clock cycle.

When the master device is reading data from the slave device, the master sends an ACK after receiving every byte of data. Following the last byte, a master device sends a “not acknowledge” (NACK) instead of an ACK, followed by a STOP condition. A NACK is indicated by leaving SDA HIGH during the clock after the last byte.

Slave Address

Each slave device on the bus must have a unique address so the master can identify which device is sending or receiving data. The FAH4830 slave address is 0000110X binary, where “X” is the read/write bit. Master write operations are indicated when X = 0. Master read operations are indicated when X = 1.

Writing to and Reading from the FAH4830

All read and write operations must begin with a START condition generated by the master. After the START condition, the master must immediately send a slave address (7 bits), followed by a read/write bit. If the slave address matches the address of the FAH4830, the FAH4830 sends an ACK after receiving the read/write bit by pulling the SDA line LOW for one clock cycle.

Setting the Pointer

For all operations, a “pointer” stored in the command register must be indicating the register to be written or read. To change the pointer value in the command register, the read/write bit following the address must be 0. This indicates that the master writes new information into the command register.

After the FAH4830 sends an ACK in response to receiving the address and read/write bit, the master must transmit an appropriate 8-bit pointer value, as explained in the I²C Registers section. The FAH4830 sends an ACK after receiving the new pointer data.

The pointer-set operation is illustrated in Figure 7 and Figure 8. Any time a pointer-set is performed, it must be immediately followed by a read or write operation. The command register retains the pointer between operations; once a register is indicated, subsequent read operations do not require a pointer set cycle. Write operations always require the pointer be reset.

Reading

If the pointer is already pointing to the desired register, the master can read from that register by setting the read/write bit (following the slave address) to 1. After sending an ACK, data transmission begins during the following clock cycle. The master should respond with a NACK, followed by a STOP condition (see Figure 5).

The master can read multiple bytes by responding to the data with an ACK instead of a NACK and continuing to send SCL pulses, as shown in Figure 6. The FAH4830 increments the pointer by one and sends the data from the next register. The master indicates the last data byte by responding with a NACK, followed by a STOP.

To read from a register other than the one currently indicated by the command register, a pointer to the desired register must be set. Immediately following the pointer-set, the master must perform a REPEAT START condition (see Figure 8), which indicates to the FAH4830 that a new operation is about to occur. If the REPEAT START condition does not occur, the FAH4830 assumes that a write is taking place and the selected register is overwritten by the upcoming data on the data bus. After the START condition, the master must again send the device address and read/write bit. This time, the read/write bit must be set to 1 to indicate a read. The rest of the read cycle is the same as described for reading from a preset pointer location.

Writing

All writes must be preceded by a pointer set, even if the pointer is already pointing to the desired register.

Immediately following the pointer-set, the master must begin transmitting the data to be written. After transmitting each byte of data, the master must release the Serial Data (SDA) line for one clock cycle to allow the FAH4830 to acknowledge receiving the byte. The write operation should be terminated by a STOP condition from the master (see Figure 7).

As with reading, the master can write multiple bytes by continuing to send data. The FAH4830 increments the pointer by one and accepts data for the next register. The master indicates the last data byte by issuing a STOP condition.

Read / Write Diagrams

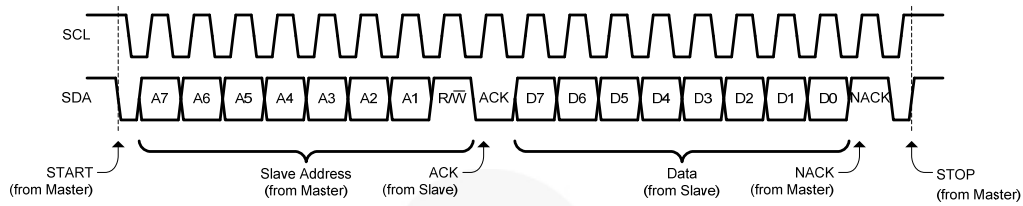

Figure 5. I²C Read

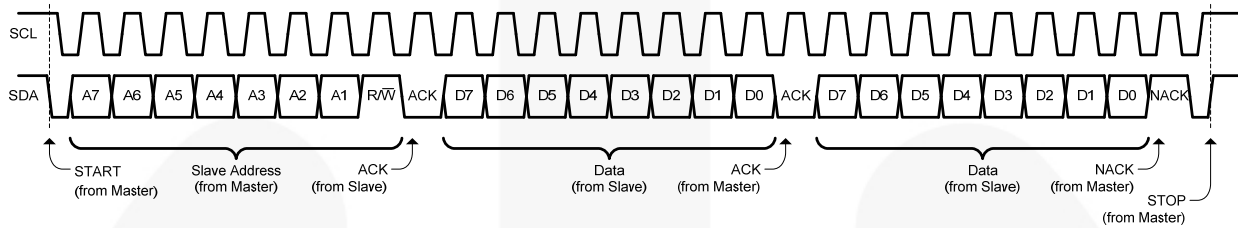

Figure 6. I²C Multiple Byte Read

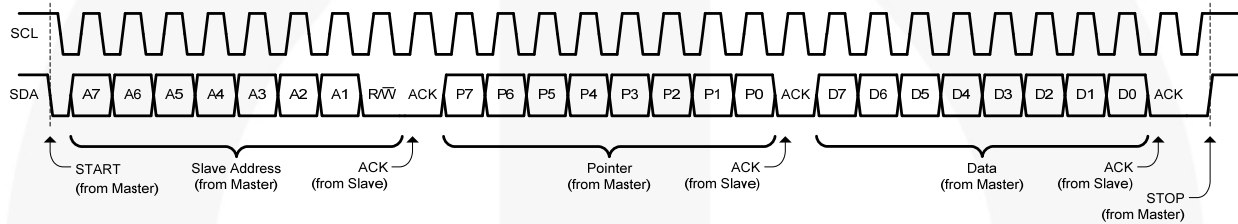

Figure 7. I²C Write

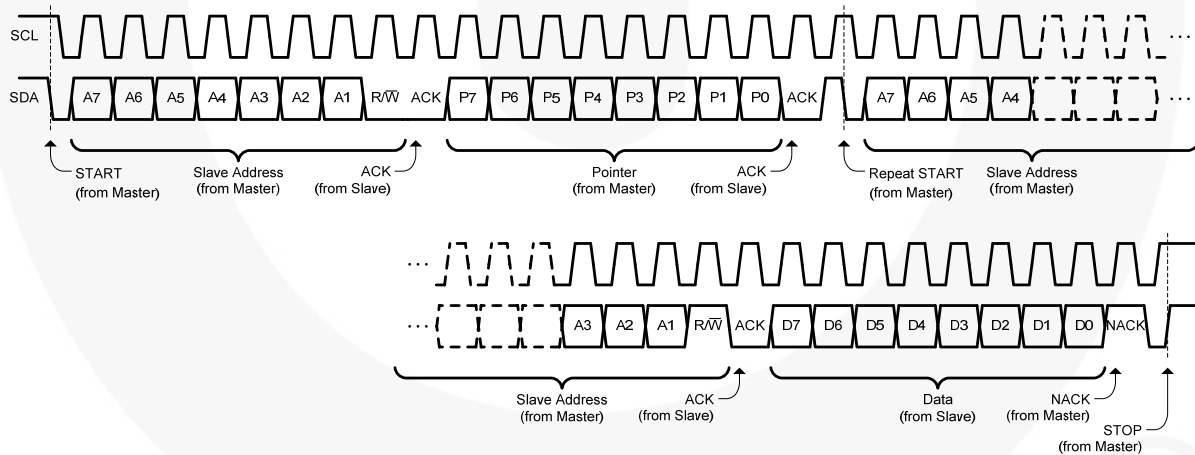

Figure 8. I²C Write Followed by Read

Digital Interface

The I²C-compatible interface is used to program the FAH4830 as listed in the below register configurations. The I²C address of the FAH4830 is 0x06.

Binary	Hex
0000110	0x06

Register Definitions

Table 1. Control Registers and Default Values

Address	Register Name	Type	Reset Value
0x20	CONTROL0	R/W	10010000
0x21	CONTROL1	R/W	00101100
0x22	Haptic_STAT	R	00001110

Table 2. Control Register MAP (Control0, Control1, Status)

Bit7	Bit6	Bit5	Bit4	Bit3	Bit2	Bit1	Bit0
Haptic_En	ODRV_EN	ODRVEN_HL	MOT_TYP	Reserved		PWM_DIV	
Input Resistance[7:5]			VLDO_OUT			Reserved	
Reserved[7:4]				VDD_G	VREG_G	OT	Reserved

Notes:

- Connect the bottom DAP to ground.

Table 3. Control 0

- Address: 20h
- Reset Value: 1001_0000
- Type: Read/Write
- BOLD** is default state

Bit #	Name	Size (Bits)	Description
7	Haptic_En	1	Haptic Drive Enable Mode 0: Power-Down Mode 1: Normal Operation Mode
6	ODRV_EN	1	Haptic Over-Drive Enable Mode (for ERM) 0: Disable Over Drive 1: Enable Over Drive
5	ODRVEN_HL	1	Selection of Over-Drive 0: Over-Drive LOW (GND RAIL) 1: Over-Drive HIGH (VDD RAIL)
4	MOT_TYP	1	Select Motor Type 0: LRA (Linear Resonant Actuator) 1: ERM (Eccentric Rotation Mass)
3:2	Reserved	2	Not used
1:0	PWM_DIV	2	Select PWM Divide 00: 1/1 01: 1/128 10: 1/256 11: 1/512

Table 4. Control 1

- Address: 21h
- Reset Value: 0010_1100
- Type: Read/Write
- **BOLD** is default state

Bit #	Name	Size (Bits)	Description
7:5	Input Resistance	3	000: 8 kΩ 001: 10 kΩ 010: 12 kΩ 011: 14 kΩ 100: 16 kΩ 101: 18 kΩ 110: 20 kΩ 111: 22 kΩ
4:2	VLDO_OUT	3	000: 2.4 V 001: 2.6 V 010: 2.8 V 011: 3.0 V 100: 3.2 V 101 :3.4 V 110: 3.6 V
1:0	Reserved	2	Not used

Table 5. Status

- Address: 22h
- Reset Value: 0000_1110
- Type: Read Only

Bit #	Name	Size (Bits)	Description
7:4	Reserved	4	Not used
3	VDD_G	1	0: Input voltage is not valid (under UVLO); input voltage is less than 2.3 V (rising) / 2.1 V (falling) 1: Input voltage is valid (over UVLO)
2	VLDO_OUT_G	1	0: Regulator output is not valid (VLDO_OUT is less than 70% of VLDO_OUT programmed) 1: Regulator output is valid
1	OT	1	0: Over-temperature protection is tripped 1: Over-temperature protection is not tripped
0	Reserved	1	Not used, default is 0

Table 6. V_{DD} vs. V_{LDO_OUT}

V _{LDO_OUT} (Programmed Voltage)	V _{DD} (V)					
	2.7	3.0	3.3	4.5	5.0	5.5
2.4	2.4	2.4	2.4	2.4	2.4	2.4
2.6	2.6	2.6	2.6	2.6	2.6	2.6
	2.8	2.8	2.8	2.8	2.8	2.8
		3.0	3.0	3.0	3.0	3.0
		3.2	3.2	3.2	3.2	3.2
			3.4	3.4	3.4	3.4
			3.6	3.6	3.6	3.6

Applications Information

The FAH4830 has the external PWM input pin for the motor driver block. In ERM Mode, the device uses the 39 nF external capacitor as an integrator. This converts the PWM output to differential DC levels on the MDP / MDN outputs.

In the LRA Mode, to control the 10 kHz to 50 kHz frequency range of the PWM input signal; the device incorporates an internal clock-dividing feature that can be modified via the I²C register settings. This allows the

user flexibility to obtain the correct resonant frequency for the chosen LRA device.

The input signal's duty cycle changes the amplitude of the positive and negative outputs for the motor drive. The LRA and ERM motor vibration strength depends on the PWM duty cycle. When the duty cycle is 50/50, the device stops. The vibration is maximum when the duty ratio is 1% to 99% or 99% to 1%. The regulator voltage level controls the amplitude of the signal at the motor.

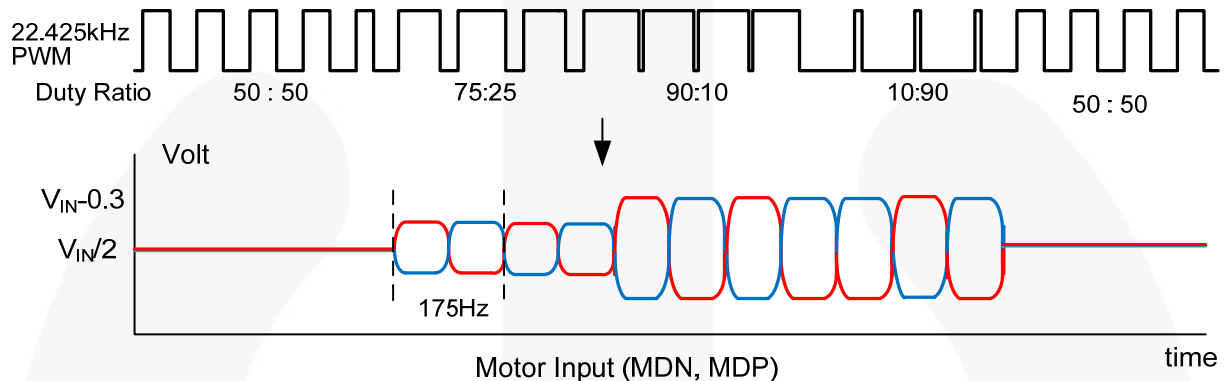

Figure 9. LRA Motor Drive (MDN, MDP)

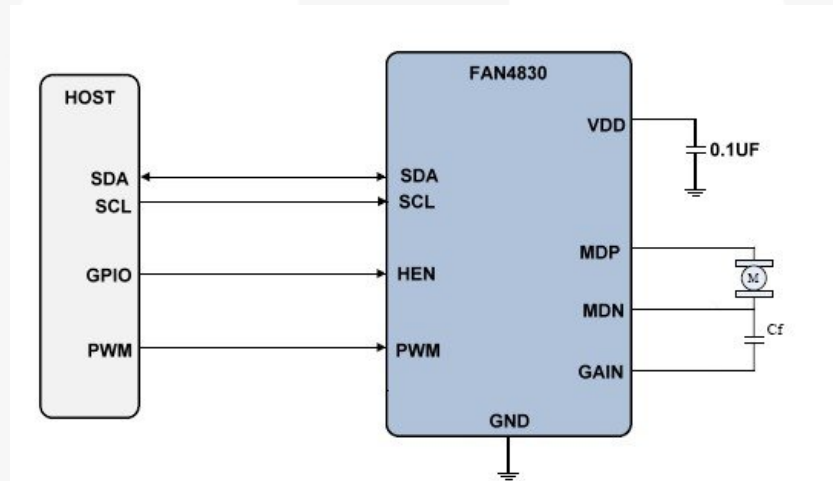

Figure 10. System Block Diagram

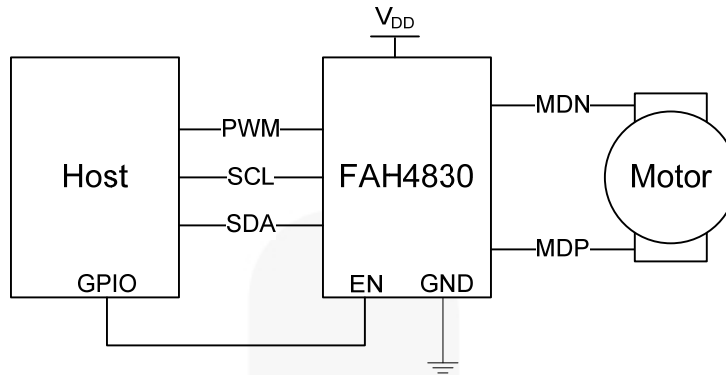
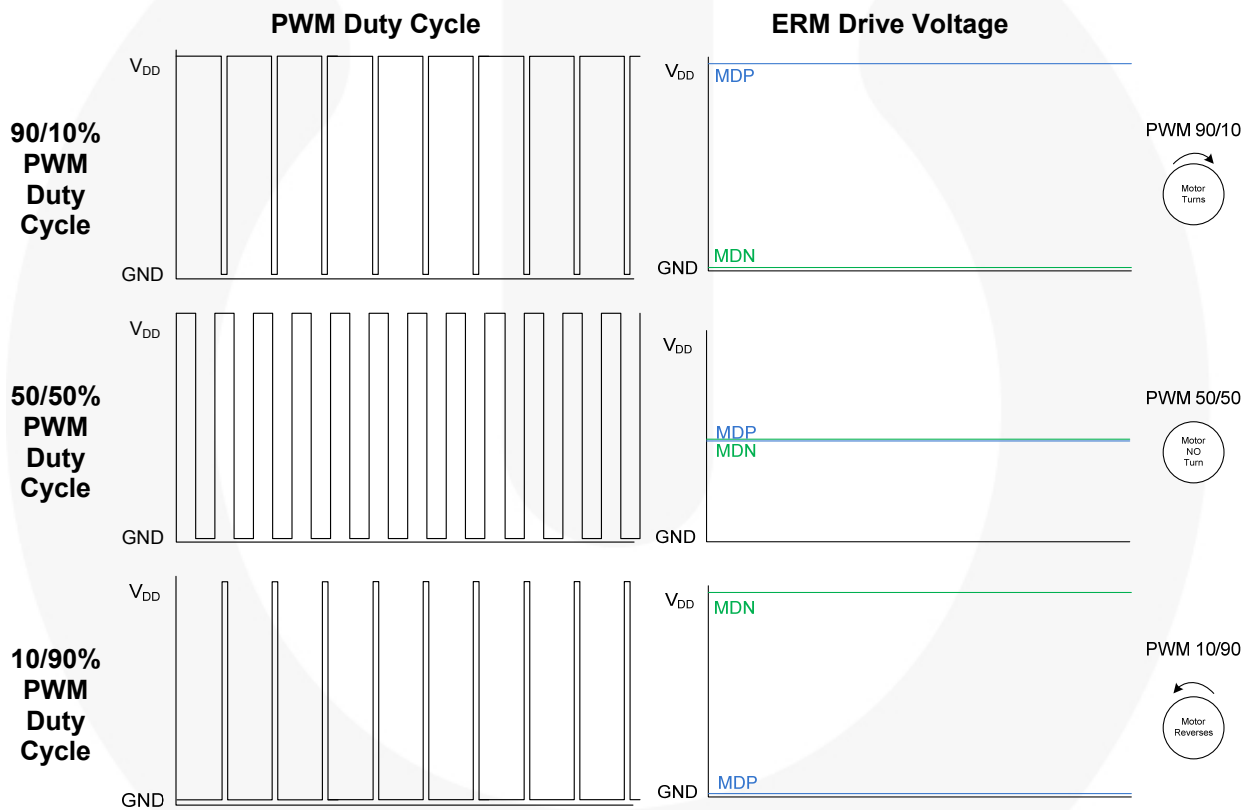

Figure 11. ERM System Block Diagram

Table 7. ERM Motor Function



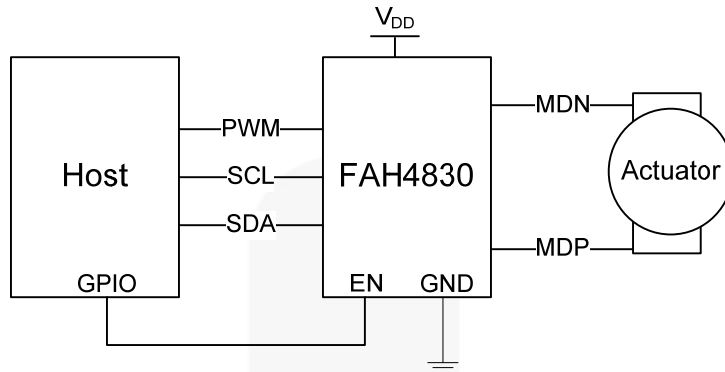
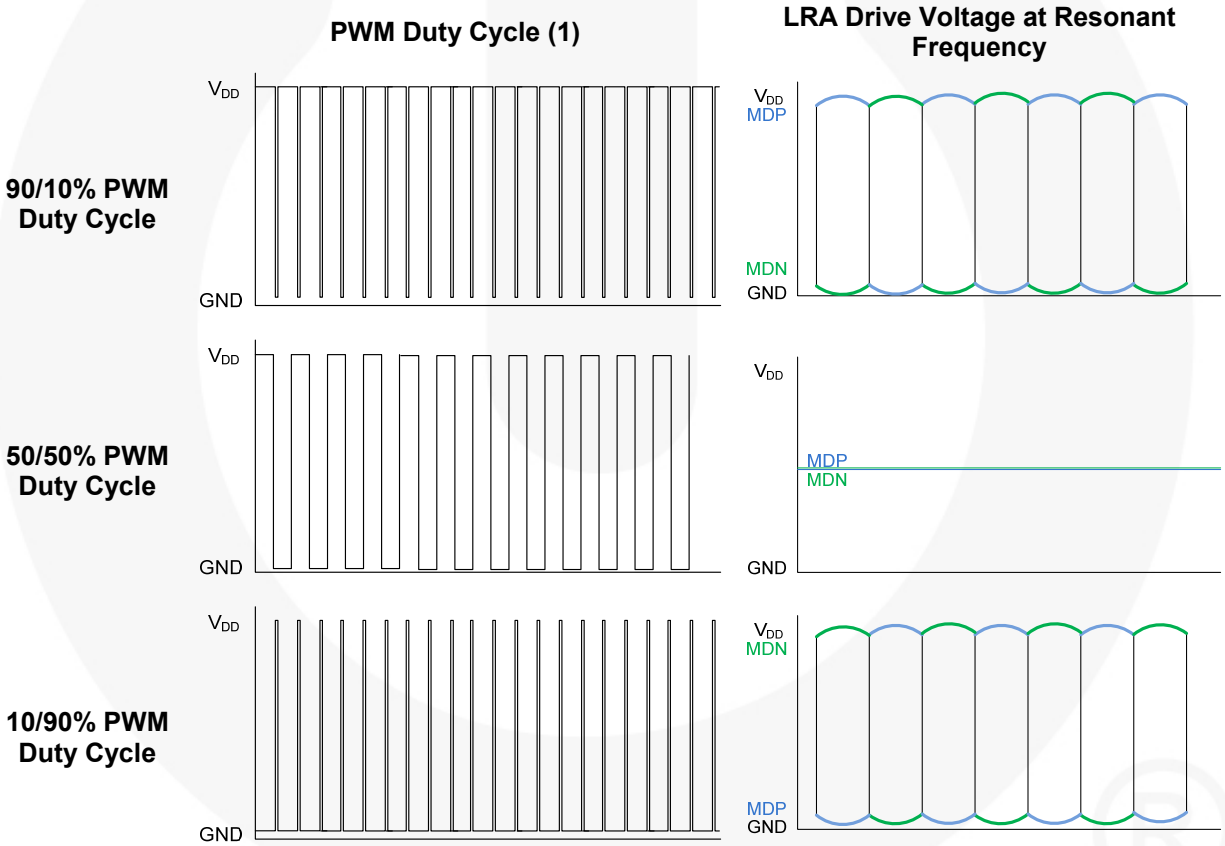

Figure 12. LRA System Block Diagram

Table 8. LRA Resonant Actuator Function



Note:

- PWM frequency is a multiple of the LRA resonant frequency, which is controlled by I²C register control 0 bit zero and one. For example, if the LRA resonant frequency is 175 Hz, the PWM frequency would be 22.4 kHz and the I²C Divide By register would be programmed to 1/128.

Filter and Gain Control

Low-Pass Filter

The C_f in Figure 1 (low-pass filter) is used to reduce the high-frequency harmonics caused by the PWM signal when the internal clock processing block operates. If C_f is increased, the lower-frequency harmonics are reduced. If the value is decreased, the higher-frequency harmonics are decreased. Usually, 39 nF is recommended for ERM devices. Verify that the cut-off frequency is higher than the resonant frequency of the haptic device. C_f is a required component for the circuit to operate properly. The low-pass filter cut-off frequency may be determined as $f_c = 1 / (2\pi R_f C)$. At default settings and $C_f = 39$ nF, the cut-off frequency is 408 Hz.

Gain Control

The gain of the FAH4830 is permanently set to a value of 1 with the internal resistors, at any programmable resistor value setting. If a motor requires a voltage less than is programmable with the LDO, an external resistor may be placed in parallel with capacitor C_f . The resultant gain is the parallel combination of external R_f and Internal R_f , divided by the R_i resistor.

Internal LDO

The internal LDO is designed for an I²C seven-step adjustable output voltage. This provides flexibility for various motor voltages and configurations for low-power consumption. The LDO includes an internal circuit for short-circuit current protection.

Serial Interface

On power-up, the device default values are invoked. The FAH4830 allows programming through the registers: the motor type, PWM dividing ratio, power down, and others functions. The device functions without any I²C input signals connected.

Thermal Shutdown

The device has thermal shutdown capability. If the junction temperature is above 150°C, the temperature control block shuts down and stays off until the temperature is below 134°C. The register values are kept as written so that it's not required to initialize again.

Over-Current Limitation

The driver includes a current-limitation block to protect against an over-current condition, mainly caused by a stuck-rotor condition. Over-current protection limitation is 500 mA typical.

Over-Drive Motor Control for ERM

A common approach to driving DC motors is to over-drive a voltage that overcomes the inertia of the motor's mass. The motor is often overdriven for a short time before returning to the motor's rated voltage to sustain rotation. The FAH4830 haptic block can over-drive a motor up to the V_{DD} voltage. Over-drive can also be used to stop (or brake) a motor quickly. The haptic driver can brake down to a voltage of GND. *Reference the motor datasheet for safe and reliable over-drive voltage and duration.* Normally, an ERM motor's rated voltage is 1.5 V, but it can be driven up to V_{DD} for an over-drive condition. The over-drive function should be used during start and stop ONLY because it can damage the ERM motor if it is used for longer than the time guaranteed in the motor datasheet. The over-drive feature also helps to eliminate long vibration tails, which are undesirable in haptic feedback systems.

This function could be used in the following steps:

1. HEN = LOW
2. PWM = 90%-10% (example)
3. ORDRVEN_HL = 1 (HIGH drive)
4. ORDVEN = 1 (enabled) apply $+V_{REG}$ to motor (start)
5. HEN = 1 (enabled motor drive)
6. ORDVEN = 0 (disabled)
7. PWM = signal (example "3 clicks")
8. ORDRVEN_HL = Low
9. ORDVEN = 1 (enabled) apply $-V_{REG}$ to motor (brake)
10. HEN = 0 (disable motor drive)
11. ORDVEN = 0 (disabled)

Over-Drive Duration

It is important that over-drive time not damage motors. The over-drive duration time must be dependent on the motor datasheet and care taken not to assert an over-voltage condition over the rated time limit of the motor.

Status Registers

The FAH4830 has a status register set that monitors LDO input voltage, regulator output voltage, and over-temperature status.

Physical Dimensions

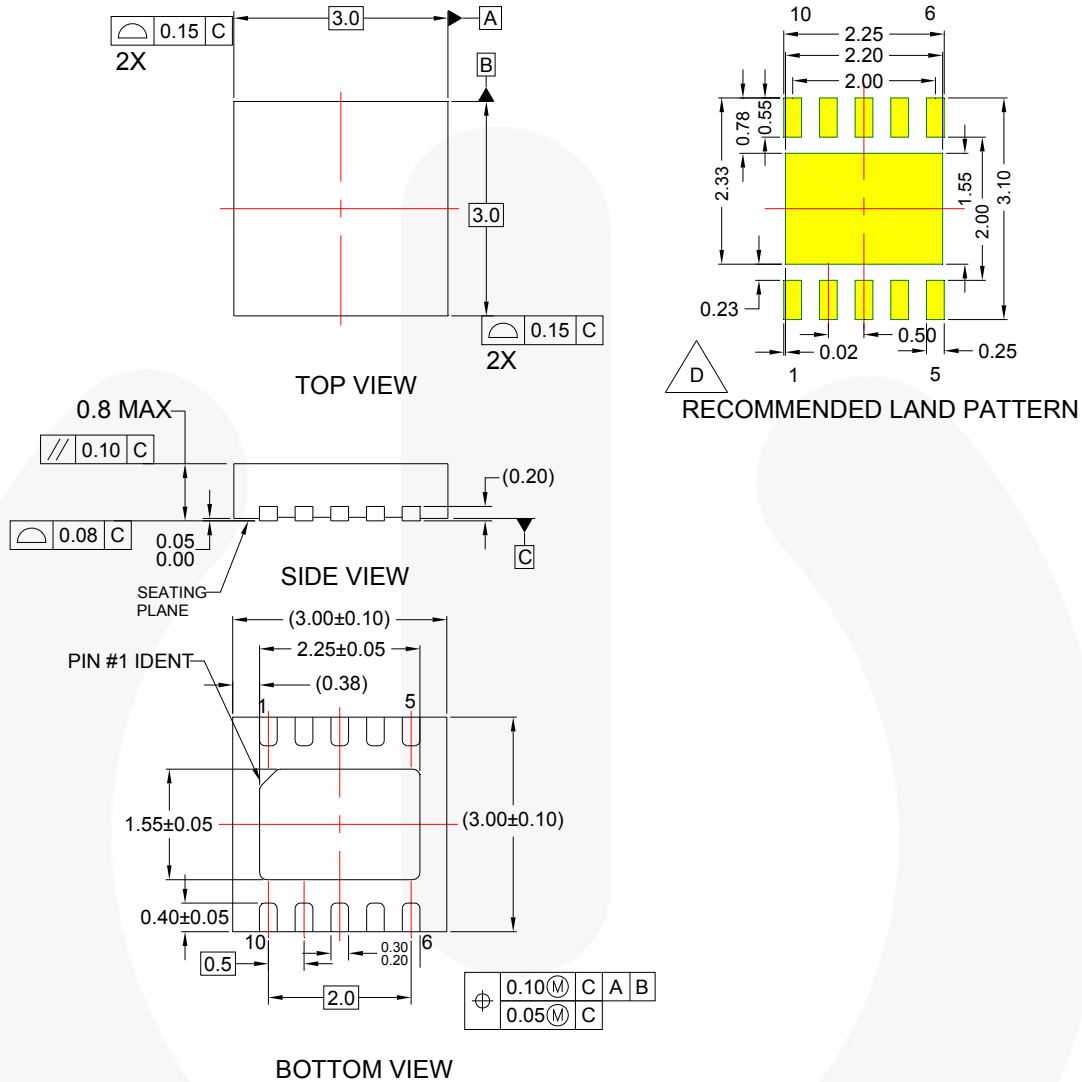

NOTES:

- A. CONFORMS TO JEDEC REGISTRATION MO-229, VARIATION WEED-5
- B. DIMENSIONS ARE IN MILLIMETERS.
- C. DIMENSIONS AND TOLERANCES PER ASME Y14.5M, 1994
- △ D. LAND PATTERN DIMENSIONS ARE NOMINAL REFERENCE VALUES ONLY

MLP10BrevA





Figure 13. 10-Lead, JEDEC MO-229, 3 mm Square, Molded Leadless Package (MLP)

Package drawings are provided as a service to customers considering Fairchild components. Drawings may change in any manner without notice. Please note the revision and/or date on the drawing and contact a Fairchild Semiconductor representative to verify or obtain the most recent revision. Package specifications do not expand the terms of Fairchild's worldwide terms and conditions, specifically the warranty therein, which covers Fairchild products.

Always visit Fairchild Semiconductor's online packaging area for the most recent package drawings:
<http://www.fairchildsemi.com/packaging/>

TRADEMARKS

The following includes registered and unregistered trademarks and service marks, owned by Fairchild Semiconductor and/or its global subsidiaries, and is not intended to be an exhaustive list of all such trademarks.

2Cool™	FPS™		Sync-Lock™
AccuPower™	F-PFS™	PowerTrench®	
AX-CAP®*	FRFET®	PowerXS™	TinyBoost™
BitSiC™	Global Power Resource™	Programmable Active Droop™	TinyBuck™
Build it Now™	GreenBridge™	QFET®	TinyCalc™
CorePLUS™	Green FPS™	QS™	TinyLogic®
CorePOWER™	Green FPS™ e-Series™	Quiet Series™	TINYOPTO™
CROSSVOLT™	Gmax™	RapidConfigure™	TinyPower™
CTL™	GTO™		TinyPVM™
Current Transfer Logic™	IntelliMAX™	Saving our world, 1mW/W/kW at a time™	TinyWire™
DEUXPEED®	ISOPLANAR™	SignalWise™	TranSiC™
Dual Cool™	Making Small Speakers Sound Louder and Better™	SmartMax™	TriFault Detect™
EcoSPARK®	MegaBuck™	SMART START™	TRUECURRENT®*
EfficientMax™	MICROCOUPLER™	Solutions for Your Success™	μSerDes™
ESBC™	MicroFET™	SPM®	
	MicroPak™	STEALTH™	UHC®
Fairchild®	MicroPak2™	SuperFET®	Ultra FRFET™
Fairchild Semiconductor®	MillerDrive™	SuperSOT™-3	UniFET™
FACT Quiet Series™	MotionMax™	SuperSOT™-6	VCX™
FACT®	mWSaver™	SuperSOT™-8	VisualMax™
FAST®	OptoHiT™	SupreMOS®	VoltagePlus™
FastvCore™	OPTOLOGIC®	SyncFET™	XS™
FETBench™	OPTOPLANAR®		

* Trademarks of System General Corporation, used under license by Fairchild Semiconductor.

DISCLAIMER

FAIRCHILD SEMICONDUCTOR RESERVES THE RIGHT TO MAKE CHANGES WITHOUT FURTHER NOTICE TO ANY PRODUCTS HEREIN TO IMPROVE RELIABILITY, FUNCTION, OR DESIGN. FAIRCHILD DOES NOT ASSUME ANY LIABILITY ARISING OUT OF THE APPLICATION OR USE OF ANY PRODUCT OR CIRCUIT DESCRIBED HEREIN; NEITHER DOES IT CONVEY ANY LICENSE UNDER ITS PATENT RIGHTS, NOR THE RIGHTS OF OTHERS. THESE SPECIFICATIONS DO NOT EXPAND THE TERMS OF FAIRCHILD'S WORLDWIDE TERMS AND CONDITIONS, SPECIFICALLY THE WARRANTY THEREIN, WHICH COVERS THESE PRODUCTS.

LIFE SUPPORT POLICY

FAIRCHILD'S PRODUCTS ARE NOT AUTHORIZED FOR USE AS CRITICAL COMPONENTS IN LIFE SUPPORT DEVICES OR SYSTEMS WITHOUT THE EXPRESS WRITTEN APPROVAL OF FAIRCHILD SEMICONDUCTOR CORPORATION.

As used herein:

- Life support devices or systems are devices or systems which, (a) are intended for surgical implant into the body or (b) support or sustain life, and (c) whose failure to perform when properly used in accordance with instructions for use provided in the labeling, can be reasonably expected to result in a significant injury of the user.
- A critical component in any component of a life support, device, or system whose failure to perform can be reasonably expected to cause the failure of the life support device or system, or to affect its safety or effectiveness.

ANTI-COUNTERFEITING POLICY

Fairchild Semiconductor Corporation's Anti-Counterfeiting Policy. Fairchild's Anti-Counterfeiting Policy is also stated on our external website, www.fairchildsemi.com, under Sales Support.

Counterfeiting of semiconductor parts is a growing problem in the industry. All manufacturers of semiconductor products are experiencing counterfeiting of their parts. Customers who inadvertently purchase counterfeit parts experience many problems such as loss of brand reputation, substandard performance, failed applications, and increased cost of production and manufacturing delays. Fairchild is taking strong measures to protect ourselves and our customers from the proliferation of counterfeit parts. Fairchild strongly encourages customers to purchase Fairchild parts either directly from Fairchild or from Authorized Fairchild Distributors who are listed by country on our web page cited above. Products customers buy either from Fairchild directly or from Authorized Fairchild Distributors are genuine parts, have full traceability, meet Fairchild's quality standards for handling and storage and provide access to Fairchild's full range of up-to-date technical and product information. Fairchild and our Authorized Distributors will stand behind all warranties and will appropriately address any warranty issues that may arise. Fairchild will not provide any warranty coverage or other assistance for parts bought from Unauthorized Sources. Fairchild is committed to combat this global problem and encourage our customers to do their part in stopping this practice by buying direct or from authorized distributors.

PRODUCT STATUS DEFINITIONS
Definition of Terms

Datasheet Identification	Product Status	Definition
Advance Information	Formative / In Design	Datasheet contains the design specifications for product development. Specifications may change in any manner without notice.
Preliminary	First Production	Datasheet contains preliminary data; supplementary data will be published at a later date. Fairchild Semiconductor reserves the right to make changes at any time without notice to improve design.
No Identification Needed	Full Production	Datasheet contains final specifications. Fairchild Semiconductor reserves the right to make changes at any time without notice to improve the design.
Obsolete	Not In Production	Datasheet contains specifications on a product that is discontinued by Fairchild Semiconductor. The datasheet is for reference information only.

Rev. I64