

DESCRIPTION

The EV1527DR-02A evaluation board is designed to drive a single Lumileds LED with low, forward voltage for Camera Flash applications. The board is set up to obtain 150mA torch current and 750mA flash current with an input voltage range of 3.0V to 4.2V. The torch and flash currents can be adjusted by resistors R2 and R3 on the Evaluation Board.

The MP1527 switches at 1.3MHz and allows the use of tiny, low cost capacitors and small inductors. External compensation and soft-start result in small inrush current and extend the battery life. The MP1527 operates from an input voltage as low as 2.6V.

ELECTRICAL SPECIFICATIONS

Parameter	Symbol	Value	Units
Supply Voltage	V_{IN}	3.0 – 4.2	V
LED Current (Torch)	I_{OUT1}	150	mA
LED Current (Flash)	I_{OUT2}	750	mA

FEATURES

- 3V to 4.2V Input Voltage Range
- Tiny Capacitors and Inductors Due to 1.3MHz Fixed Switching Frequency
- Output LED Currents: 150mA at Torch Mode, 750mA at Flash Mode
- Surface-Mount Components
- Fully Assembled and Tested

APPLICATIONS

- Camera Phone Flash
- Handheld Computers and PDAs
- Digital Still and Video Cameras
- External Modems
- Small LCD Displays
- White LED Drivers

"MPS" and "The Future of Analog IC Technology" are Registered Trademarks of Monolithic Power Systems, Inc.

EV1527DR-02A EVALUATION BOARD



(L x W x H) 2.0" x 2.2" x 0.5"
(5.0cm x 5.6cm x 1.0cm)

Board Number	MPS IC Number
EV1527DR-02A	MP1527DR

Load Transient

$V_{IN} = 3.6V$ (1 LED)

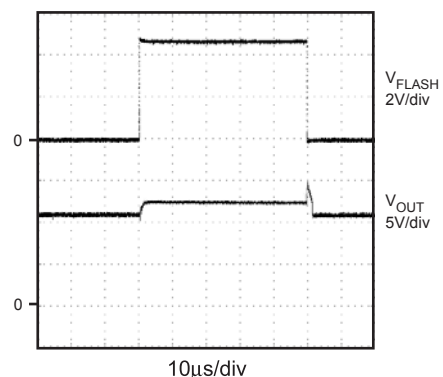

EV1527DR-02A_WF01

EVALUATION BOARD SCHEMATIC

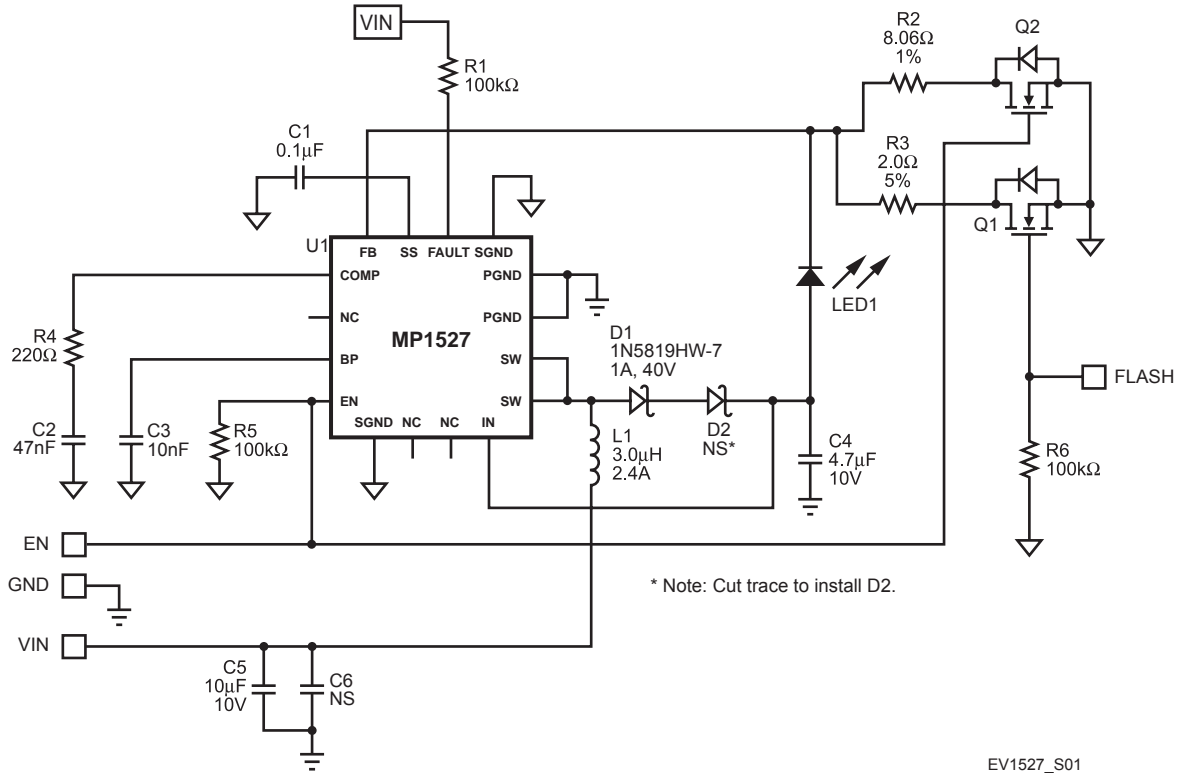

EV1527DR-02A BILL OF MATERIALS

Qty	Ref	Value	Description	Package	Manufacturer Part Number
1	C1	0.1µF	Ceramic Capacitor, 16V, X7R	0603	AVX: 0603YC104KAT
1	C2	47nF	Ceramic Capacitor, 25V, X7R	0603	AVX: 06033C473KAT
1	C3	10nF	Ceramic Capacitor, 50V, X7R	0603	AVX: 06035C103KAT
1	C4	4.7µF	Ceramic Capacitor, 10V, X5R	1210	AVX: 1210YD475KAT2W
1	C5	10µF	Ceramic Capacitor, 10V, X7R	1210	AVX: 1210YD106KAT2W
1	C6		Not Stuffed		
1	D1		Schottky Diode, 1A, 40V	SOD123	Diodes Inc.: 1N5819HW-7
1	D2		Not Stuffed		
1	L1	3.0µH	Inductor, 2.4A	S	Sumida: CDRH5D28-3R0NC
1	LED1		Not Stuffed		

EV1527DR-02A BILL OF MATERIALS (continued)

Qty	Ref	Value	Description	Package	Manufacturer Part Number
2	Q1, Q2		N-Channel MOSFET, 4.5A, 20V	SOT23-6	Zetex Inc.: ZXMN2A03E6TA
3	R1, R5, R6	100k Ω	Resistor, 5%	0603	Panasonic: ERJ-3GEYJ104V
1	R2	8.06 Ω	Resistor, 1%	0805	Yageo: 9C08052A8R06FGHFT
1	R3	2.0 Ω	Resistor, 5%	1210	Panasonic: ERJ-14YJ2R0U
1	R4	220 Ω	Resistor, 5%	0603	Panasonic: ERJ-3GEYJ221V
1	U1		Step-Up Converter	QFN16	MPS: MP1527DR

PRINTED CIRCUIT BOARD LAYOUT

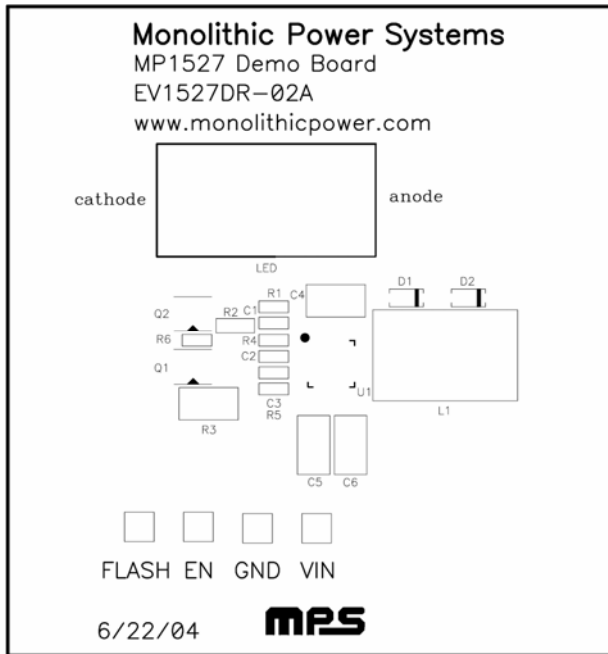

Figure 1—Top Silk Layer

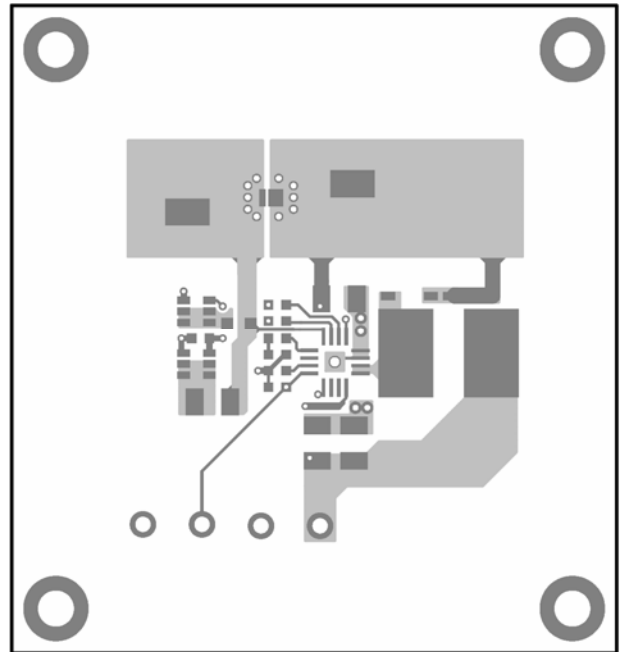

Figure 2—Top Layer

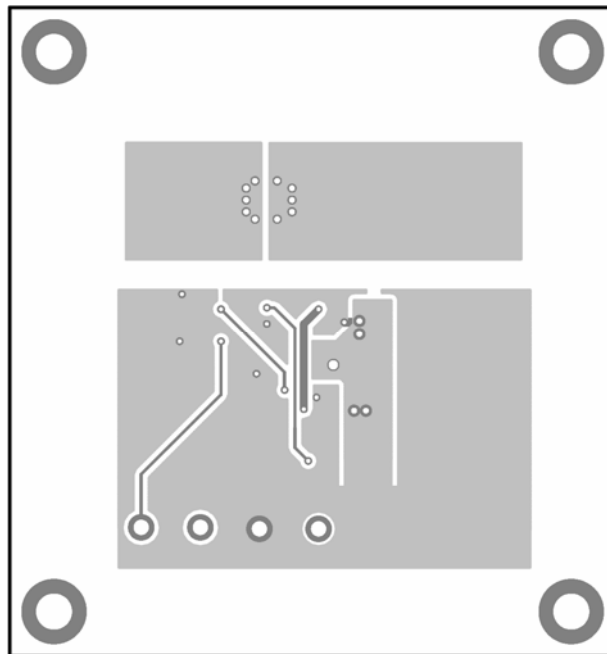

Figure 3—Bottom Layer

QUICK START GUIDE

1. Connect a Lumileds DS25 to LED terminals on the EV1527DR-02A board.
2. Preset the power supply to 3V - 4.2V.
3. Turn the power supply off.
4. Connect the power supply terminals to:
 - a. Positive (+): VIN
 - b. Negative (-): GND
5. Connect EN to VIN.
6. Turn on the power supply after making said connections.
7. The MP1527 is enabled on the demo board once V_{IN} is applied.
8. Drive FLASH of Q1 with a pulsed signal (3V or above for High, 0V for Low) to switch between two (2) LED currents.
9. I_{OUT1} is set to 150mA on the board.
10. I_{OUT2} is set to 750mA on the board.

NOTICE: The information in this document is subject to change without notice. Please contact MPS for current specifications. Users should warrant and guarantee that third party Intellectual Property rights are not infringed upon when integrating MPS products into any application. MPS will not assume any legal responsibility for any said applications.