

- IEEE 802.3 and IEEE 802.5 compatible
- Robust construction allows IR/VP reflow processes
- Operating Temperature : 0°C to +70°C
- 500 Vrms Hipot

Electrical Parameters @ 25° C

OCL ($\mu\text{H} \pm 20\%$)	Leakage Inductance (μH Max.)	Interwinding Capacitance (pF Max.)	ET Product (V-uS)	Insulation Resistance (G Ω Min.)	DCR (Ω Max.)
100 KHz, 0.1 Vrms	100 KHz, 0.1 Vrms	100 KHz, 0.1 Vrms		@ 500 Vdc	
85	0.25	15 Line to Line	2.5	10 Line to Line	0.2 Each Line

Schematic

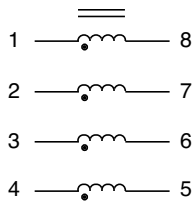

Typical Impedance

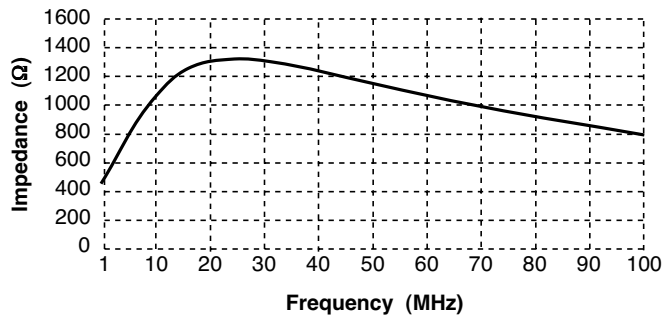

Package

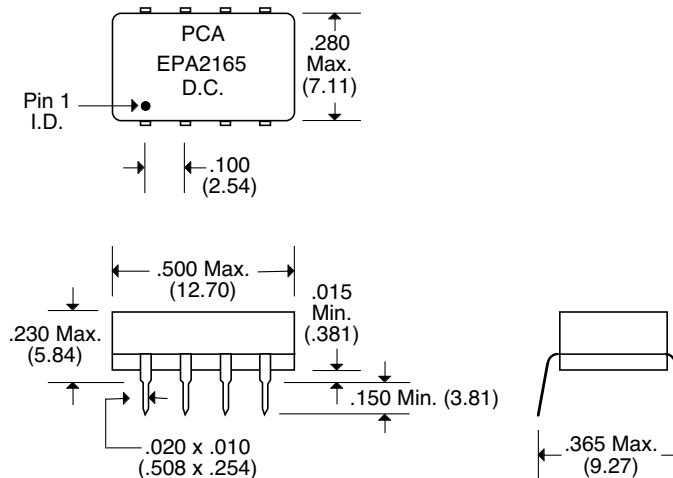

Unless Otherwise Specified Dimensions are in Inches /mm $\pm .010 / .25$