

## Table of Contents

<b>1. Introduction</b>	
1.1 Description .....	2
1.2 Pin Configurations .....	2
1.3 Features .....	3
<b>2. Device Functions</b>	
2.1 Block Diagram .....	5
2.2 Pin Description .....	6
<b>3. Electrical Specifications</b>	
3.1 Absolute Maximum Ratings .....	8
3.2 Recommended operating conditions.....	9
3.3 Electrical characteristics .....	10
3.4 AC Characteristics .....	11
3.5 I/O Circuits .....	14
<b>4. Architecture</b>	
4.1 Overview .....	16
4.2 Register File .....	16
4.3 Peripheral File (PF) .....	17
4.4 Stack Pointer (SP) .....	18
4.5 Status Register (ST) .....	18
4.6 Program Counter (PC) .....	19
4.7 Peripheral File Map .....	19
4.8 Interrupt and Reset Priorities .....	22
<b>5. Function</b>	
5.1 Input/Output Ports .....	24
5.2 Device Initialization .....	28
5.3 I/O Control Register .....	28
5.4 Interrupt Logic and External Interrupt.....	34
5.5 Programmable Timer / Event Counter.....	37
5.6 A/D Converter .....	45
5.7 I2C .....	49
5.8 6-bit PWM (PWM1_0, PWM1_8) .....	63
5.9 14-bit PWM (PWM0) .....	68
5.10 On Screen Display .....	73
<b>6. OTP Deivce Specifications</b>	
6.1 Pin Assignment of OTP programming Adapter Board.....	83
6.2 Package Descriptions (Mechanical Data) .....	88
<b>* Appendix : OSD Font Design Guide</b> .....	89



## 1. INTRODUCTION

### 1.1 Description

The DMC73C167 is an 8-bit CMOS microcontroller with 16K bytes of on-chip ROM, 256 bytes of on-chip RAM, OSD (On Screen Display), A/D converter, 10 PWM output ports, three timers, multi-master I2C communications port, 8 output only pins, and 20 normal I/O pins. The high-performance CPU internal peripherals allow flexible design in industrial equipment, televisions, camcorders, VCRs, and other home appliances.

### 1.2 Pin Configurations

PWM0 (14bit) ←	1	54 ←	VCC
PWM1_0 (6bit) ←	2	53 ↔	A7
PWM1_1 (6bit) ←	3	52 ↔	SCL
PWM1_2 (6bit) ←	4	51 ↔	SDA
PWM1_3 (6bit) ←	5	50 ↔	A6
PWM1_4 (6bit) ←	6	49 ↔	A5/INT5_0
PWM1_5 (6bit) ←	7	48 ↔	A4/INT3_0
PWM1_6 (6bit) ←	8	47 ↔	A3/INT1
PWM1_7 (6bit) ←	9	46 ↔	A1/ECI1
PWM1_8 (6bit) ←	10	45 ←	/RESET
B0/T1OUT(OPEN D) ←	11	44 →	OSC OUT(CPU)
B1/T3OUT(OPEN D) ←	12	43 ←	OSC IN(CPU)
B2(OEPN DRAIN) ←	13	42 ←	TEST
B3(OEPN DRAIN) ←	14	41 ↔	A2/ECI2
B4(OEPN DRAIN) ←	15	40 →	OSC OUT(OSD)
B5(OEPN DRAIN) ←	16	39 ←	OSC IN(OSD)
B6(OEPN DRAIN) ←	17	38 ←	/Vsync
B7(OEPN DRAIN) ←	18	37 ←	/Hsync
A0/4BIT ADC ↔	19	36 →	Yout or /Yout
C0 ↔	20	35 →	BLUE
C1 ↔	21	34 →	GREEN
C2 ↔	22	33 →	RED
C3 ↔	23	32 ↔	D3
C4 ↔	24	31 ↔	D2
C5 ↔	25	30 ↔	D1
C6 ↔	26	29 ↔	D0
VSS →	27	28 ↔	C7



### 1.3 Features

- **8-bit architecture with CMOS technology**
- **Flexible memory configurations**
  - 16K-bytes on-chip ROM
  - 256-byte on-chip RAM register file
  - Memory-mapped I/O ports for easy addressing
- **Three on-chip timers**
  - One 16-bit timer with 5-bit prescaler, 16-bit capture latch, and timer outputs
  - Two 8-bit timers with 2-bit prescaler, 8-bit capture latch, and timer outputs
  - Direct connection of timer clock through I/O ports for event counting
  - Generate Internal interrupts and automatic timer reload
- **One On-chip A/D converter**
  - 4-bit resolution with successive approximation conversion
  - Conversion speed of 40 machine cycles
- **On-chip OSD generator**
  - Display pattern :           20 columns x  2 lines (hardware)  
  20 columns x 12 lines (software)
  - Character font :           12 dots x 18 dots
  - Number of characters : 128 fonts
  - Color :                       8 colors per character
- **Ten PWM D/A converters**
  - One 14-bit PWM output port with polarity control
  - Nine 6-bit PWM output ports with polarity control
- **On-chip I2C bus interface hardware**
  - Master mode operation
  - Slave mode operation
  - Multi-master mode operation

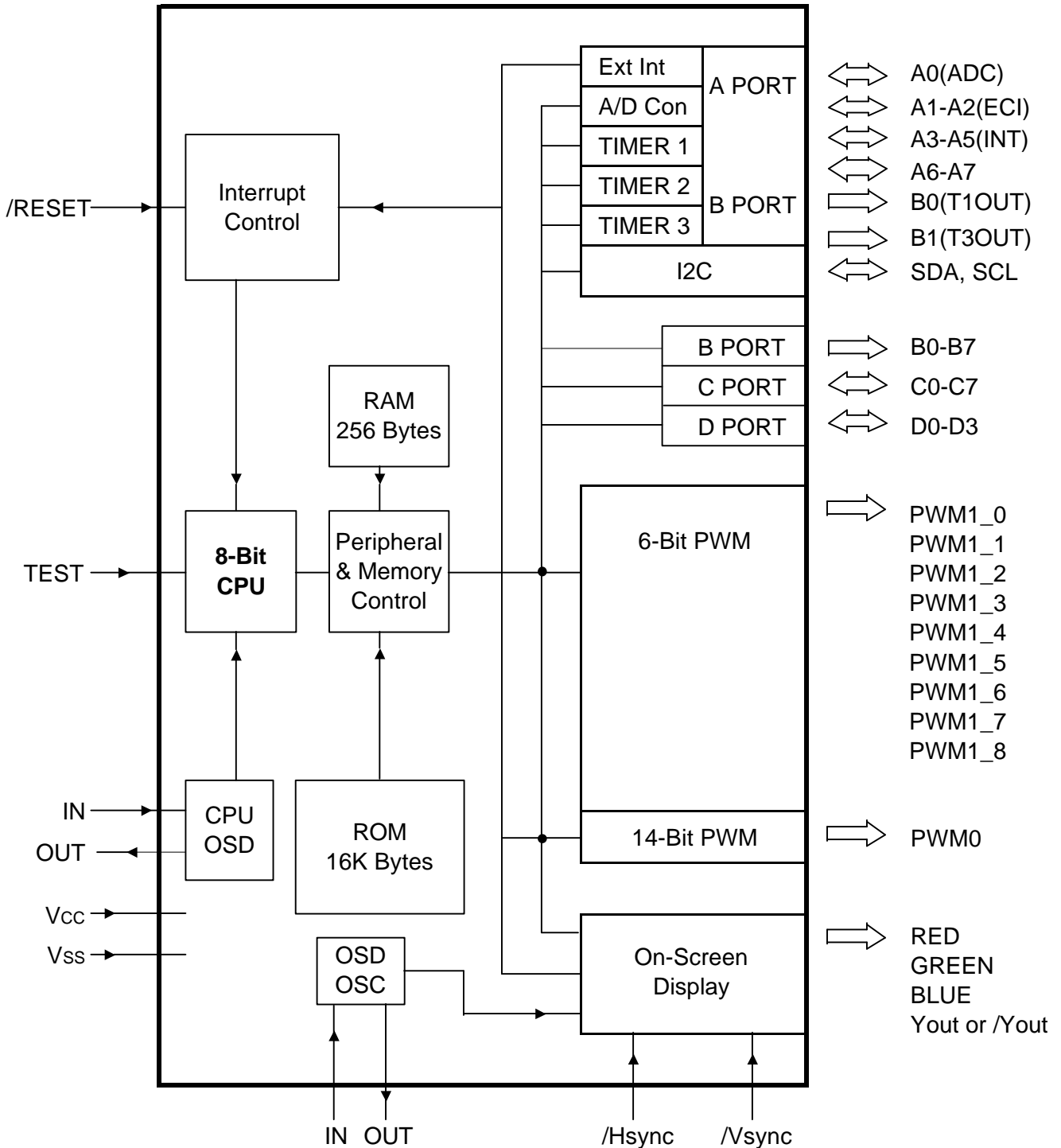


- **Flexible interrupt handling and powerful instruction set**
  - Three external interrupts with schmitt trigger input
  - No limitation on sub-routine calls (dependent on stack size only)
  - Software calls through vector table (maximum 24 vectors)
  - Software monitoring of interrupt status
  - Precise interrupt timing through capture latch
  - Global and individual interrupt masking
  - Bit, nibble, word manipulation, and multiply / divide instructions
- **General purpose input/output ports**
  - Eight output only pins
  - 20 input/output pins
- **Operating range**
  - CPU clock :                   2MHz to 6MHz
  - OSD clock :                   3MHz to 8MHz
  - Temperature :                0 °C to 70 °C
- **Package**
  - Primary :                      54-pin Shrink dual in line package
  - OTP :                           54-pin Shrink dual in line package
- **Development support**
  - System evaluation and piggyback prototyping device : SE73CP87B
  - Low-cost evaluation module : EVM73C00A and ADP73C167
  - OTP : TMS73CE167
  - Assembler/linker cross-support for popular hosts



2. DEVICE FUNCTIONS

2.1 Block Diagram



## 2.2 Pin Description

Pin Symbol	Pin Number		I/O	Function	Description
	Primary	SE			
PWM0	1	1	O	14-bit PWM output	CMOS output PWM1_0 to PWM1_8 are output pins with +12V open drain
PWM1_0	2	2	O	6-bit PWM output 0	
PWM1_1	3	3	O	6-bit PWM output 1	
PWM1_2	4	4	O	6-bit PWM output 2	
PWM1_3	5	5	O	6-bit PWM output 3	
PWM1_4	6	6	O	6-bit PWM output 4	
PWM1_5	7	7	O	6-bit PWM output 5	
PWM1_6	8	8	O	6-bit PWM output 6	
PWM1_7	9	9	O	6-bit PWM output 7	
PWM1_8	10	10	O	6-bit PWM output 8	
B0/T1OUT	11	11	O	Output, Timer 1 clock out	B0 to B3 are optional use for open-drain output with +12V buffer
B1/T3OUT	12	12	O	Output, Timer 3 clock out	
B2	13	13	O	Output	
B3	14	14	O	Output	
B4	15	15	O	Output	B4 to B7 are optional use for open-drain output with 12mA drive(+5V) or internal pull up(+5V) resistor by mask option
B5	16	16	O	Output	
B6	17	17	O	Output	
B7	18	18	O	Output	
A0	19	19	I/O	ADC input or normal I/O	4-bit A/D converter or normal I/O internal pull up(+5V) resistor (mask option)
C0	20	20	I/O	Digital I/O	C0 to C7 are normal I/O pins and internal resistors can be optionally pulled up(+5V ) during masking process
C1	21	21	I/O		
C2	22	22	I/O		
C3	23	23	I/O		
C4	24	24	I/O		
C5	25	25	I/O		
C6	26	26	I/O		
VSS	27	27	I		Ground reference
C7	28	38	I/O		
D0	29	39	I/O	Digital I/O	D0 to D3 are normal I/O pins and internal resistors can be optionally pulled up(+5V) during masking process
D1	30	40	I/O		
D2	31	41	I/O		
D3	32	42	I/O		



## 2.2 Pin Description (Continued)

Pin Symbol	Pin Number		I/O	Function	Description
	Primary	SE			
RED	33	43	O	OSD red color output	CMOS output
GREEN	34	44	O	OSD green color output	CMOS output
BLUE	35	45	O	OSD blue color output	CMOS output
Yout	36	46	O	OSD blanking signal	Active high or low(mask option)
/HYSNC	37	47	I	H SYNC input	OSD H position reference
/VSYNC	38	48	I	V SYNC input	OSD V position reference
OSCI_OSD	39	49	I		Clock input for OSD
OSCO_OSD	40	50	O		Clock output for OSD
A2(ECI2)	41	51	I/O	I/O, Timer 2 clock input	Internal pull-up(+5V) resistor (mask option). Event counter or normal I/O
TEST	42	52	I	Should be fixed to 0	For device test
OSCI_CPU	43	53	I		Clock input for CPU
OSCO_CPU	44	54	O		Clock output for CPU
/RESET	45	55	I		For CPU reset
A1(ECI1)	46	56	I/O	I/O, Timer 1 clock input	Event counter or normal I/O
A3(INT1)	47	57	I/O	External interrupt 1	With Schmitt trigger
A4(INT3_0)	48	58	I/O	External interrupt 3_0	With Schmitt trigger
A5(INT5_0)	49	59	I/O	External interrupt 5_0	With Schmitt trigger
A6	50	60	I/O	Digital I/O	A0 to A6 can be optionally pulled up(+5V) during masking process
SDA	51	61	I/O	Data pin for I2C	Open drain(+5V) with Schmitt input
SCL	52	62	I/O	Clock pin for I2C	
A7	53	63	I/O	Digital I/O	Internal pull-up(+5V) resistor (mask option)
VCC	54	64	I		4.5V-5.5V



### 3. ELECTRICAL SPECIFICATIONS

#### 3.1 Absolute Maximum Ratings

Parameter		Symbol	Rating	Unit
Supply voltage range*		VCC	-0.3 through 7.0	V
Input voltage range		VI	-0.3 through VCC +0.3	V
Output voltage range	Port B0-B3, PWM1_n		-0.3 through 15.0	V
	Except B0-B3, PWM1_n		-0.3 through VCC +0.3	
Input current		II	±10	mA
Output current	Port B4-B7	IO	Max 20	mA
	Except B4-B7		Max 10	
Total low-level output current		IOL	Max 120	mA
Power dissipation		PD	0.5	W
Storage temperature range		TSTG	-55 through +125	°C

\*Unless otherwise noted, all voltages are with respect to VSS.

Test pin must connect to VSS.

Pull-up resistor option is not counted in the electrical specifications.

Stresses beyond those listed under "Absolute Maximum Ratings" may cause permanent damage to the device. This is a stress rating only and functional operation of the device at these or any other conditions beyond those indicated in Section "Recommended Operating Conditions" of this specification is not implied.

Exposure to absolute-maximum-rated conditions for extended periods may affect device reliability.





### 3.2 Recommended Operating Conditions

Parameter	Symbol	Port	Min	Typ	Max	Unit
Supply voltage*	VCC		4.5		5.5	V
Operating free-air temperature range**	TOPR		-10		70	Deg
High-level input voltage	VIH	OSC IN***	VCC-0.7		VCC	V
		Except OSC IN****	VCC-1.0		VCC	V
Low-level input voltage	VIL	OSC IN***	VSS		0.4	V
		Except OSC IN****	VSS		1.1	V
Positive-going threshold	VT+ #	A3-A5, /RESET	2.5		4.0	V
Negative-going threshold	VT- #	A3-A5, /RESET	1.0		2.0	V
Hysteresis	VH #	A3-A5, /RESET, /Hsync, /Vsync, SCL, SDA	1.0			V
Open-drain port supply voltage		PORT B0-B3, PWM1_n	4.5	12	14.0	V
		PORT B4-B7, SCL, SDA	4.5	5	5.5	V
Analog input voltage		A0	VSS		VCC	V

\* Ripple must not exceed 50mVp-p

\*\* See A/D Converter Characteristics

\*\*\* OSCIN means both CPU and OSD OSCIN

\*\*\*\* Except Schmitt-trigger inputs

££ VCC = 5.0V



### 3.3 Electrical Characteristics

Parameter	Symbol	Port	Min	Typ	Max	Unit
Input current	II	VI=VSS-VCC			±10.0	mA
High-level output current	IOH	VOH=VCC-0.5V	-0.3			mA
Low-level output current	IOL	SCL, SDA VOL=0.4V		3		mA
		B4-B7 VOL=1.0V		12	16	
		Except SCL, SDA, B4-B7 VOL=0.4V	1.7			
High-level output voltage	VOH	IOH= -0.3mA	VCC-0.5		VCC	V
Low-level output voltage	VOL	IOL=1.7mA			0.4	V
Low-level output leakage current	ILEAK	B0-B3, PWM1_n VO=12V			±10	uA
		Excpet B0-B3, PWM1_n VO=VCC			±10	
Internal pull-up resister option	II	VDD=5.0V VI=VSS	-60	-90	-120	uA
Clock frequency	FOSC	CPU clock	3.0		6.0	MHz
	OSDCLK	OSD clock	4.0		8.0	
Input capacitance	CI				15.0	pF
Supply current*	ICC	Operation mode		12.0	20.0	mA
		Halt mode		5	20	uA

\*All I/O terminals which except CLKIN are open and VCC=5V.



### 3.4 AC Characteristics

#### ● I/O Port

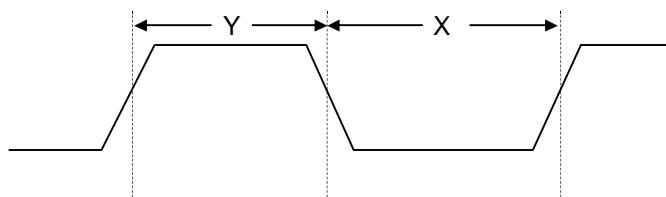
Parameter	Port	Conditions	Min	Typ	Max	Unit
I/O Port output rise time	SCL SDA B0-B7 PWM1_n*	CL=50pF			1	us
	Except SCL, SDA, B0-B7, PWM1_n	CL=15pF		30	60	ns
		CL=50pF			150	
I/O Port output fall time	SCL SDA B0-B7 PWM1_n*	CL=50pF			1	us
	Except SCL, SDA, B0-B7, PWM1_n	CL=15pF		10	40	ns
		CL=50pF			70	

\* External pull-up registers are needed in PWM1\_n, B0-B3.

External pull-up registers are also needed in SCL, SDA. The values would be recommendable to fit rise and falling time of I2C spec.

#### ● Clock I/O

Parameter	Symbol	Min	Typ	Max	Unit
Clock pulse	Rise time			20	ns
	Fall time			10	ns
	Duty cycle	dty(c)	45	50	55



$$\text{DUTY}(\%) = \frac{X \text{ or } Y}{Tc(c)} \times 100 \quad Tc(c) = X + Y$$

Note : Timing points are 90%(high) and 10%(low).

- Externally Driven Clock Input Waveform -



## 3.4 AC Characteristics (Continued)

## ● A/D Converter

Parameter	Test Conditions	Min	Typ	Max	Unit
Resolution	TOPR = -10°through +70° VCC = 5V±10% VSS = 0V, FOSC = 6MHz			4	bit
Non-linearity			±1/2	±1	LSB
Zero error					
Full-scale error					
Conversion time*				13.3	µS

\* External sample hold circuit is required during 40 machine cycle times. Resolution is dependent on ripple supply voltage( $V_{CC} < V_{REF}$ ). Ripple must not exceed 5mVp-p.

## ● I2C

Parameter	Symbol	Min	Max	Unit
SCL clock frequency	fSCL	0	100	KHz
Time the bus must be free before a new transmission can start*	tBUF	4.7		µs
Hold time start condition*	tHD;STA	4		µs
Low period of the clock*	tLOW	4.7		µs
High period of the clock*	tHIGH	4		µs
Setup time for start condition*	tSU;STA	4.7**		µs
Hold time data	tHD;DAT	0		µs
Setup time data	tSU;DAT	250		ns
Rise time of both SDA and SCL lines	tR		1	µs
Fall time of both SDA and SCL lines	tF		300	ns
Setup time for stop condition*	tSU;STO	4.7		µs

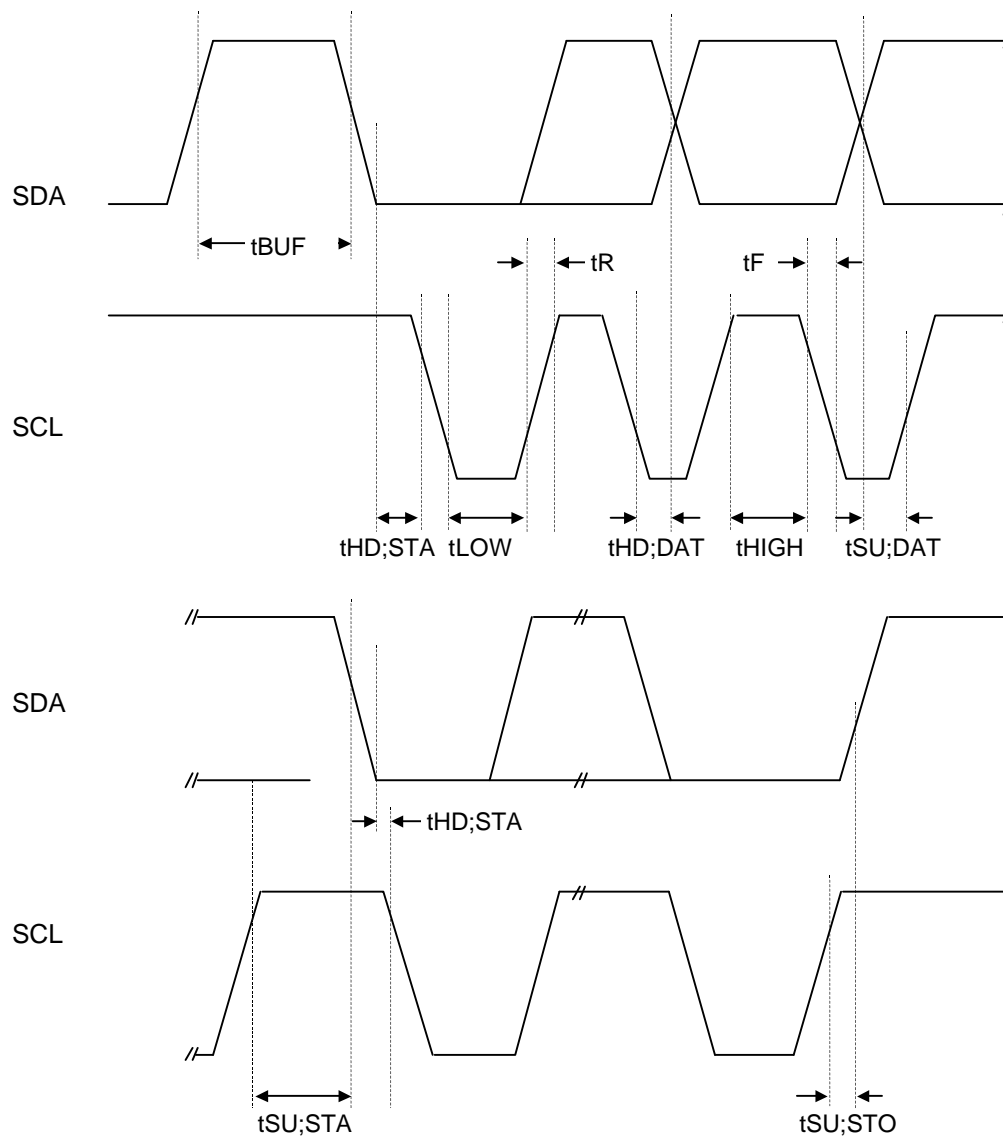
\* The value is like above when the digital filter is off. Add 4/Fosc to this value when the digital filter is on.

\*\* This time must be satisfied by the software delay.



## 3.4 AC Characteristics (Continued)

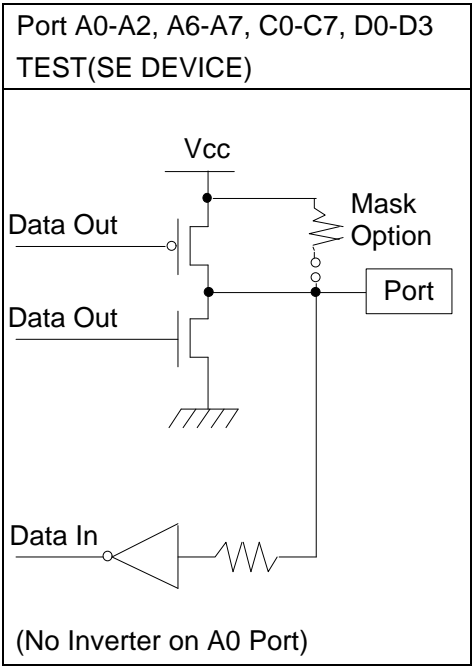
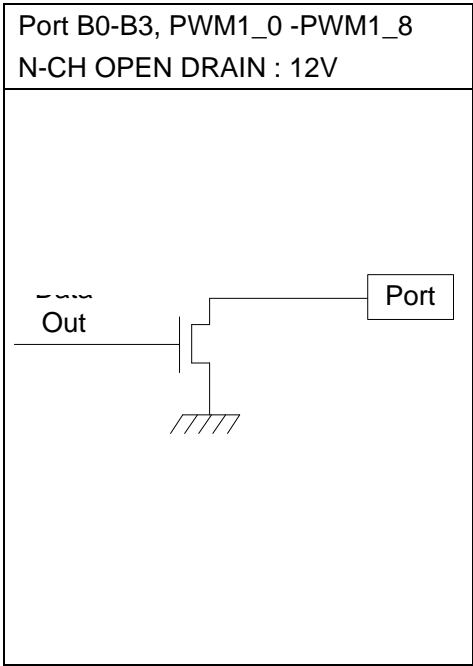
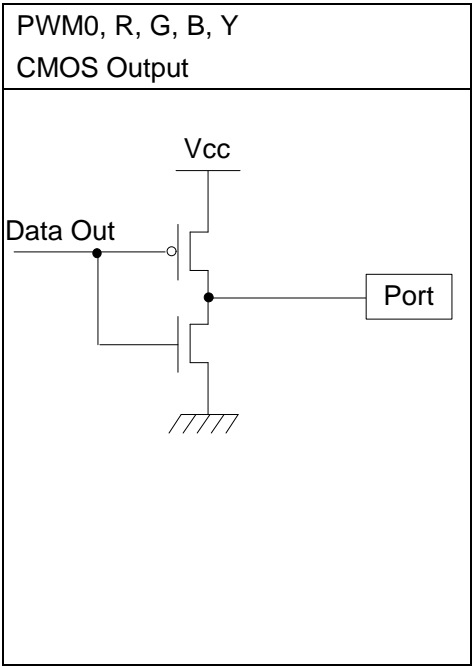
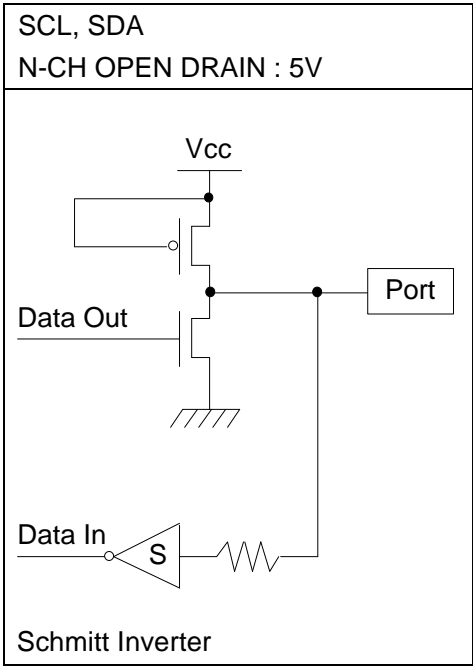
## ● I2C (Continued)



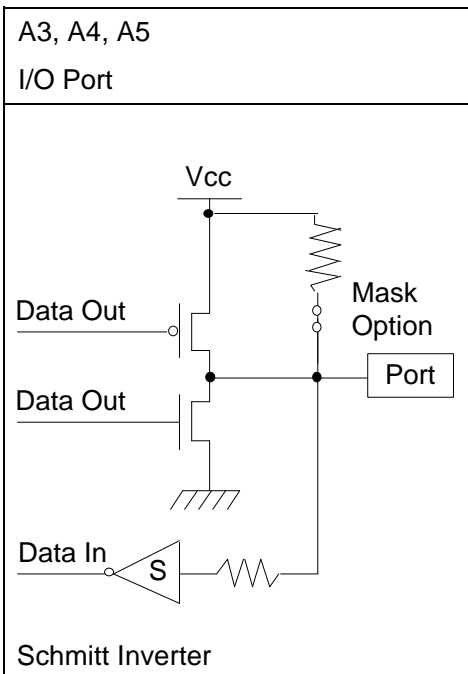
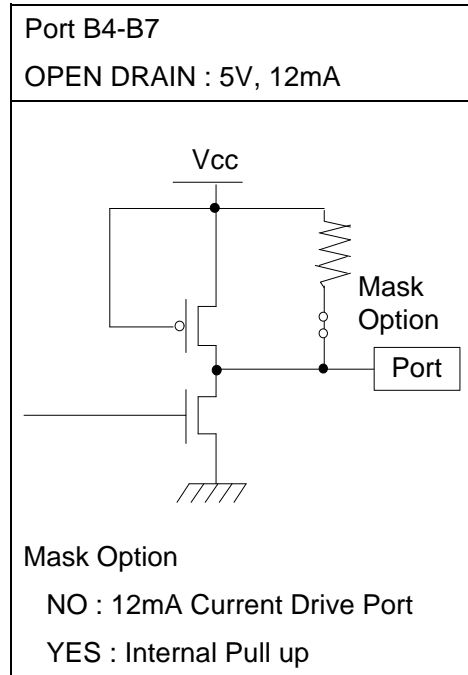
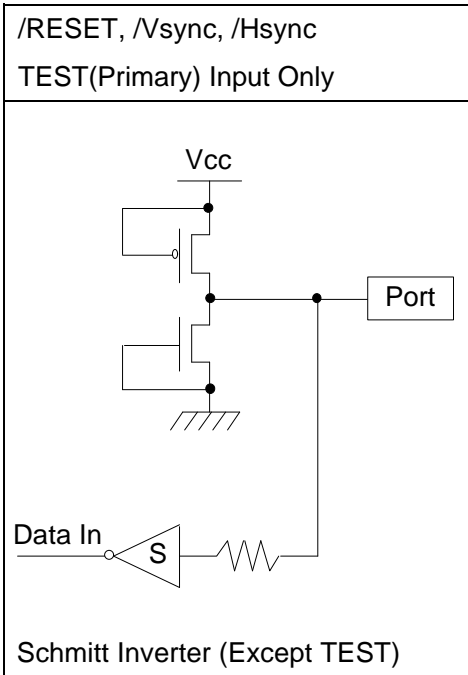
- Timing for I2C Bus -



3.5 I/O Circuits



3.5 I/O Circuits (Continued)



## 4. ARCHITECTURE

### 4.1 Overview

The DMC73C167 has a maximum memory address space of 16 kbytes on-chip ROM and only a single-chip mode. On-chip memory spaces are configured as shown in Figure 4-1 below. In the section that follows, the register file (RF) and the peripheral file (PF) are described along with three important registers in the CPU: the stack pointer (SP), the status register (ST), and the program counter (PC).

Figure 4-1. DMC73C167 Memory Maps

Memory address

0000h	Register File (RF)	00FFh
0100h	Peripheral File (PF)	01FFh
0200h	Not Available	C005h
C006h	16Kbytes ROM	FFFFh

### 4.2 Register File (RF)

The 256-byte on-chip RAM resides in locations 0000h to 00FFh of the DMC73C167's address space and is called the register file (RF). The RAM is treated as a register by much of the instruction set and is numbered R0-R255. The first two registers, R0 and R1, are also called the A and B registers, respectively. Several instructions specify A or B as either the source or destination register. For example, STSP stores the contents of the stack pointer (SP) in the B register. Except where stated otherwise, any register in the register file can be addressed as an 8-bit source or destination register. The stack is also located in the register file. Refer to Section 4.4 for information regarding the initialization of the stack pointer and stack definition in the register file.





### 4.3 Peripheral File (PF)

The peripheral file (PF) resides in location 0100h to 01FFh of the DMC73C167's address space. Some of the instructions are optimized for efficient access to and from the registers that reside in the peripheral file. Peripheral file locations are number P0-P255. The PF registers are used for interrupt control, parallel I/O, timer control, 14-bit PWM, OSD, 6-bit PWM, I2C and A/D converter control. On screen Display RAM (video RAM) is also mapped in the peripheral file.

Figure 4-2. DMC73C167 Peripheral File Map

Memory address

100h	P0 : P75	Peripheral Registers
14Bh 14Ch	P76 : P95	Reserved
15Fh 160h	P96 : P115	Line A Video RAM
173h 174h	P116 : P127	Reserved
17Fh 180h	P128 : P147	Line B Video RAM
193h 194h	P148 : P255	Not Available
1FFh		

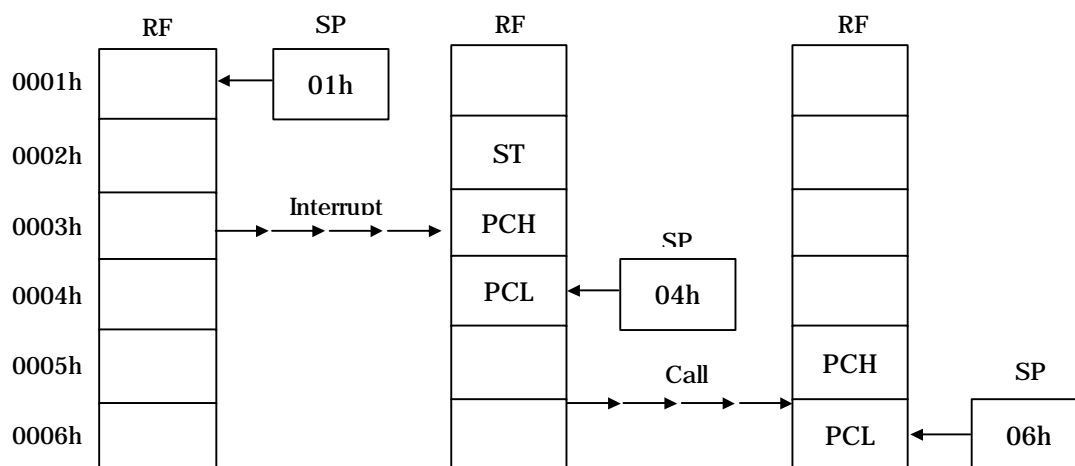


#### 4.4 Stack Pointer (SP)

The stack pointer(SP) is an 8-bit register in the CPU which is typically used to hold a pointer in RAM (the register file). However, the SP can also be used as temporary data storage if a stack is not implemented, or if the SP contents are not needed.

When a stack is implemented, the SP points to the last or top entry on the stack. The SP is automatically incremented just before data is pushed onto the stack and automatically decremented immediately after data is popped from the stack. Upon assertion of the RESET function (see Section 4.8) 01h is loaded into the SP. The size of the stack can be changed from the 255-level stack at RESET to a smaller stack by executing a stack initialization program as illustrated in Figure 4-3. This feature allows the stack to be located anywhere in the register file. The SP is initialized through the B register (R1).

Figure 4-3. Example of Stack Initialization in the Register File



#### 4.5 Status Register (ST)

The status register(ST) is an 8-bit register in the CPU that contains three conditional status bits : carry(C), sign(N), and zero(Z). It also contains a global interrupt enable bit(I) as shown in Figure 4-4 below.

Figure 4-4. Status Register (ST)

Bit	7	6	5	4	3	2	1	0
Con	C	N	Z	I	Future use			

C = carry out, N=sign, Z = zero, I = Interrupt enable



The C, N and Z bits are used mostly for arithmetic operations, bit rotating, and conditional branching. The carry (C) bit is used as the carry-in and the carry-out for most of the rotate and arithmetic instructions. The sign(N) bit contains the most significant bit of the destination operand contents after instruction execution. The zero(Z) bit contains a 1 when all bits of the destination operand are equal to zero after instruction execution.

The C, N, and Z status bits also have jump-on-condition instructions associated with them. The global interrupt enable(I) bit must be set to 1 by the EINT instruction in order for any of the individual interrupts (INTn) to be recognized by the CPU. The interrupt enable(I) bit can be cleared by the DINT instruction or by executing a device RESET (see Section 4.8).

#### 4.6 Program Counter (PC)

The DMC73C167's 16-bit program counter (PC) consists of two 8-bit registers in the CPU which contain the MSB and the LSB, respectively, of a 16-bit address, the program counter high (PCH) and program counter low (PCL). The PC acts as the 16-bit address pointer of the opcodes and operands in the memory of the currently executing instruction. Upon assertion of the RESET function, the MSB and the LSB of the PC are loaded into the A and B registers of the register file (see Section 4.8).

#### 4.7 Peripheral File Map

The peripheral file(PF) resides in location 0100h through 01FFh of the DMC73C167's address space, as shown in Tables 4-2.

Note : The right-end column, headed "Value After Reset", indicates a reset initial value as shown in Table 4-1.

Table 4-1. Description of "Value After Reset"

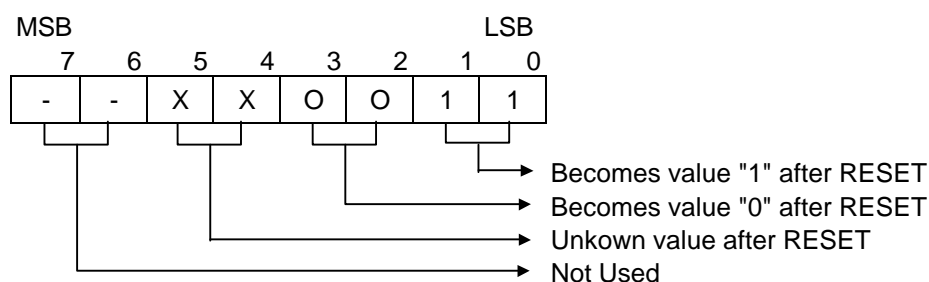


Table 4-2. Peripheral File Map

Number	Address	Label	R/W	Contents	Value after Reset	
					MSB	LSB
P0	0100h	IOCTL0	R/W	Interrupt control	0	
P1	0101h	IOCTL1	R/W	Interrupt control 1	- - - -	
P2	0102h	IOCTL2	R/W	Interrupt control 2	- - - - -	
P3	0103h	IOCTL3	R/W	Interrupt control 3	0	
P4	0104h	IOCTL4	R/W	Interrupt control 4	- - 0	
P5	0105h	-	-	Reserved		
P6	0106h	ADATA	R	A Port data	X X X X X X X X	
P7	0107h	ADIR	R/W	A Port direction register	0	
P8	0108h	BDATA	R/W	B Port data	1	
P9	0109h	-	-	Reserved		
P10	010Ah	CDATA	R/W	C Port data	X X X X X X X X	
P11	010Bh	CDIR	R/W	C Port direction	0	
P12	010Ch	DDATA	R/W	D Port data	- - - - X X X X	
P13	010Dh	DDIR	R/W	D Port direction	- - - -	
P14	010Eh	-	-	Reserved		
P15	010Fh	-	-	Reserved		
P16	0110h	ADCTL	R/W	A/D control	- 0	
P17	0111h	ADDATA	R	A/D data	- - - -	
P18	0112h	-	-	Reserved		
P19	0113h	-	-	Reserved		
P20	0114h	T1MSD	R/W	Timer 1 MS data	X X X X X X X X	
P21	0115h	T1LSD	R/W	Timer 1 LS data	X X X X X X X X	
P22	0116h	T1CTL0	R/W	Timer 1 control	X X X X X X	
P23	0116h	T1CTL1	R	Timer 1 control 1	X X X X X X	
P24	0117h	T2DATA	R/W	Timer 2 data	X X X X X X X X	
P25	0119h	T2CTL	R/W	Timer 2 control	X X X X X X	
P26	011Ah	T3DATA	R/W	Timer 3 data	X X X X X X X X	
P27	011Bh	T3CTL	R/W	Timer 3 control	- - - - X X	
P28	011Ch	-	-	Reserved		
P29	011Dh	-	-	Reserved		
P30	011Eh	-	-	Reserved		
P31	011Fh	-	-	Reserved		
P32	0120h	PWM0CTL	R/W	14-bit PWM control	- - - - -	
P33	0121h	WAKEMS	R/W	Wake up MS counter	- - 0	
P34	0122h	WAKELS	R/W	Wake up LS counter	0	
P35	0123h	PWM0AT	W	14-bit PWM add time	- - 0	
P36	0124h	PWM0BT	W	14-bit PWM base time	0	
P37	0125h	PWM1CTL	R/W	6-bit PWM control	- - - - - - -	
P38	0126h	PWM1_0T	W	PWM1_0 polarity and time	- 0	
P39	0127h	PWM1_1T	W	PWM1_1 polarity and time	- 0	
P40	0128h	PWM1_2T	W	PWM1_2 polarity and time	- 0	



Table 4-2. Peripheral File Map (Continued)

Number	Address	Label	R/W	Contents	Value after Reset	
					MSB	LSB
P41	0129h	PWM1_3T	W	PWM1_3 polarity and time	-	0
P42	012Ah	PWM1_4T	W	PWM1_4 polarity and time	-	0
P43	012Bh	PWM1_5T	W	PWM1_5 polarity and time	-	0
P44	012Ch	PWM1_6T	W	PWM1_6 polarity and time	-	0
P45	012Dh	PWM1_7T	W	PWM1_7 polarity and time	-	0
P46	012Eh	PWM1_8T	W	PWM1_8 polarity and time	-	0
P47	012Fh	-	-	Reserved		
P48	0130h	MCTL0	R/W	I2C master control 0	-	0
P49	0131h	MCTL1	R/W	I2C master control 1	-	-
P50	0132h	MSTS	R/W	I2C master status	0	-
P51	0133h	MDATA	R/W	I2C master data	X	X
P52	0134h	HDC	R/W	I2C master high duration	X	X
P53	0135h	LDC	R/W	I2C master low duration	X	X
P54	0136h	SADDR	W	I2C slave address	X	X
P55	0137h	SDATA	R/W	I2C slave data	X	X
P56	0138h	SCTL	R/W	I2C slave control	-	-
P57	0139h	DFCTL	R/W	I2C digital filter control	-	-
P58-P67	013Ah-0143h	-	-	Reserved for on-chip PF		
P68	0144h	OSDCTL	R/W	OSD control register	-	-
P69	0145h	OSDHP	W	OSD horizontal position	-	1
P70	0146h	OSDVPA	W	LINE A vertical position		1
P71	0147h	OSDVPB	W	LINE B vertical position		1
P72	0148h	VPCNTR	R	Vertical display counter	-	-
P73-P75	0149h-014Bh	-	-	Reserved		
P77-P95	0150h-015Fh	-	-	Reserved for on-chip PF		
P96-P115	0160h-0173h	-	W	OSD LINE A video RAM	X	X
P128-P147	0180h-0193h	-	W	OSD LINE B video RAM	X	X
P148-P255	0194h-01FFh	-	-	Not available		



#### 4.8 Interrupt and Reset Priorities

The DMC73C167 has priority servicing of five interrupt levels and RESET. These levels are defined as shown in Table 4-3. The TRAP instructions branch to two-byte location in a reserved section of memory called the TRAP vector table. As shown in Figure 4-5, each trap location stores a 16-bit address that references either the reset function (TRAP0), one of the five interrupt service routines (TRAP1-INT1, TRAP2-INT2, TRAP3-INT3, TRAP4-INT4, TRAP5-INT5), or a subroutine (TRAP6-23). Once the interrupt has been acknowledged, the CPU then pushes the contents of the status register and the program counter (MSB and LSB) onto the stack and zeros the status register, including the global interrupt Enable (I) bit. The CPU reads an interrupt code from the interrupt logic and branches to the address contained in the corresponding interrupt vector location in memory. The interrupt service routine can explicitly enable nested interrupts by executing the EINT instruction to directly set the I bit in the status register to 1, thus permitting routine is completed, it returns to the previous interrupt service routine by executing the RETI instruction.

Table 4-3. Interrupt and Reset Priorities

Level	Name	Source	Trigger Factor	Vector	
				MSB	LSB
0	/Reset	External	Active Low	FFFEh	FFFFh
1	INT1	External	Falling/Rising	FFFCh	FFFDh
2	INT2_0 INT2_1	Timer 1 Timer 2	Timer 1 underflow Timer 2 underflow	FFFAh	FFFBh
3	INT3_0 INT3_1	External Timer 3	Falling/Rising Timer3 underflow	FFF8h	FFF9h
4	INT4	OSD	OSD enable	FFF6h	FFF7h
5	INT5_0 INT5_1 INT5_2	External 12C master 12C slave	Falling/Rising Data ready from slave Slace address selected	FFF4h	FFF5h



Figure 4-5. TRAP Vector Table

Address	
FFD0h	TRAP23 (MSB) *
FFD1h	TRAP23 (LSB) **
/	////////
FFEFh	TRAP8 (A0-A7)
FFF0h	TRAP7 (MSB)
FFF1h	TRAP7 (LSB)
FFF2h	TRAP6 (MSB)
FFF5h	INT5 or TRAP5 (LSB)
FFF7h	INT4 or TRAP4 (LSB)
FFF8h	INT3 or TRAP3 (MSB)
FFF9h	INT3 or TRAP3 (LSB)
FFFAh	INT2 or TRAP2 (MSB)
FFFBh	INT2 or TRAP2 (LSB)
FFFC	INT1 or TRAP1 (MSB)
FFFDh	INT1 or TRAP1 (LSB)
FFFEh	RESET or TRAP0 (MSB)
FFFFh	RESET or TRAP0 (LSB)

\* MSB = A8-A15

\*\* LSB = A0-A7



## 5. FUNCTION

### 5.1 Input/Output Ports

The DMC73C167 has 28 I/O pins organized as four parallel ports labeled A, B, C and D. Each port is mapped into 4- to 8-bit data value registers in the peripheral file (PF). The data value registers are usually called APORT, BPORT, CPORT and DPORT in a program. Ports A, C and D are implemented as bidirectional I/O ports.

Port B is an open-drain output only port with a 12 V buffer (B0-B3) and 12mA current drive capability (B4-B7).

Each bidirectional port (that is, Port A, C and D) has a corresponding data direction register (DDR) that programs each I/O pin as an input or output pin. A bit set to 1 in the DDR will cause the corresponding pin to be an output pin, while a 0 in the DDR will turn the pin into a high-impedance input pin. Upon RESET, the DDR flip-flop registers are set to 0 by the on-chip circuitry, forcing them to become inputs. Also upon RESET, the output data registers of the output only port (that is, Port B) are set to 1 by the on-chip circuitry. And, other output data registers are indeterminate data set.

After RESET, if 1s are written to the DDR register sometime before the output data register is changed, then the corresponding I/O pins will output a 1. For this reason, it is good practice to load the output data registers of Ports A, C and D with the desired value before any bits are configured as outputs. In addition, DMC73C167 has several mask options related to the I/O pins such as pull-up resistors. Those I/O pins are individually configurable at the masking stage. For a detailed description of the I/O pins in the DMC73C167, see table 3-2.

#### 5.1.1 A Port

Pins A0 to A7 of A port are bidirectional I/O ports and several hardware-related functions are interfaced with the CPU through this port. Pin A0 can be used as an analog input for the on-chip A/D converter. Pin A1 and A2 can be used for the event counter input of Timer 1 and Timer 2, respectively. Pin A3, A4 and A5 can be used for the Schmitt-buffered external interrupt input for INT1, INT3\_0, and INT5\_0, respectively.

Reading the port - A data register (P6) returns each value at the A0 - A7 pins if the corresponding DDR bit is set to 0 and returns each output buffer register value if the DDR bit is 1. The user can specify internal pull-up (5V) resistor insertion or not selectively for port A pins (mask option).

Table 5-1. P7 0107h ADDR A Port Direction

Bit	7	6	5	4	3	2	1	0
R	ADDR7	ADDR6	ADDR5	ADDR4	ADDR3	ADDR2	ADDR1	ADDR0
W								





Table 5-2. P6 0106h ADATA A Port Data

Bit	7	6	5	4	3	2	1	0
R	ADATA7	ADATA6	ADATA5	ADATA4	ADATA3	ADATA2	ADATA1	ADATA0
W								
Special	-	-	INT5_0	INT3_0	INT1	ECI2	ECI1	ADIN

Table 5-3. A Port Control Register Operation

ADDRn	Driection	ADATAn(Read)	ADATAn(Write)
0	Input Port	0 ; Input 'Low'	Invalid
		1 : Input 'High'	
1	Output Port	Written Data	0 ; Output 'Low'
			1 : Output 'High'

**Note :**

Special usage for Pin A0 to A5 is as follows.

ADIN : Analog signal for 4-bit ADC is acceptable through Pin A0. Bit 0 for the A/D control register (ADCTL, P16) controls digital input or analog input.

To use analog input, pin A0 must be in input mode (ADDR0-0).

ECI1 : Event counter input for Timer 1

The external clock from Pin A1 can be directly connected to the clock source of Timer 1. T1SRC (bit 5 of P22) selects the source of Timer 1.

See Timer 1 operation for more details.

ECI2 : Event counter input for Timer 2.

The external clock from Pin A2 can be directly connected to the clock source of Timer 2. T2SRC (bit 5 of P25) selects the source of Timer 2.

See Timer 2 operation for more details.

INT1 : External interrupt 1 is triggered by the falling and rising transition of Pin A3, which must be in input mode to be used as an interrupt source. This pin can also be used as a normal input port while the interrupt is activated.

INT3\_0 : External interrupt 3\_0 is triggered by the falling and rising transition of Pin A4, which must be in input mode to be used as an interrupt source. This pin can also be used as a normal input port while the interrupt is activated.



INT5\_0 : External interrupt 5\_0 is triggered by the falling and rising transition of Pin A5, which must be the input mode to be used as an interrupt source. This pin can also be used as a normal input port while the interrupt is activated.

### 5.1.2 B Port

Pins B0 to B7 of B Port are output only pins. Pins B0 to B3 contain a high-voltage buffer (12V nominal) with open-drain output and Pins B4 to B7 contain a high-current output buffer (12mA nominal). Pins B0 and B1 can be used as the clock output of Timer 1 and Timer 3, respectively. In the DMC73C167, the user can specify the internal pull-up (5V) resistor for the B4 to B7 ports selectively (mask option).

Table 5-4. P8 0108h BDATA B Port Data

Bit	7	6	5	4	3	2	1	0
R								
W								
Special	-	-	-	-	-	-	T3OUT	T1OUT

The B Port control register operation is as follows.

**WRITE** : Setting the BDATA<sub>n</sub> bit to 1 outputs logic high status to the same pin number and setting BDATA<sub>n</sub> bit to 0 outputs logic low status to the same pin number.

**READ** : External pins are not accessed through the read operation. The CPU can read data from B Port but it is the contents of the output buffer register written by the CPU previously.

**Note** : Special usage for Pins B0 and B1 is as follows.

**T1OUT** : Clock output for Timer 1

Underflow of Timer 1 MSB decrement register toggles the logic level of Pin B0  
When bit 6 of T1CTL0 (P22) is set to 1.

**T3OUT** : Clock output for Timer 3

Underflow of Timer 3 decrement register toggles the logic level of Pin B1 when  
bit 6 of T2CTL (P25) is set to 1.



### 5.1.3 C Port

The C Port is an 8-bit bidirectional I/O port any of those eight pins can be individually programmed as input and output lines under software control. In the DMC73C167, the user can specify internal pull-up (5V) resistor insertion or not selectively for port C pins (mask option)

Table 5-5. P11 0108h CDDR C Port Direction

Bit	7	6	5	4	3	2	1	0
R								
W	CDDR7	CDDR6	CDDR5	CDDR4	CDDR3	CDDR2	CDDR1	CDDR0

Table 5-6. P10 010Ah CDATA C Port Data

Bit	7	6	5	4	3	2	1	0
R								
W	CDATA7	CDATA6	CDATA5	CDATA4	CDATA3	CDATA2	CDATA1	CDATA0

Table 5-7. C Port Control Register Operation

CDDRn	Direction	CDATAN(Read)	CDATAN(Write)
0	Input Port	0 ; Input 'Low'	Invalid
		1 : Input 'High'	
1	Output Port	Written Data	0 ; Output 'Low'
			1 : Output 'High'

### 5.1.4 D Port

The D Port is a 4-bit bidirectional I/O port any of those four pins can be individually programmed as input and output lines under software control. In the DMC73C167, the user can specify internal pull-up (5V) resistor insertion or not selectively for port D pins (mask option).

Table 5-8. P13 010Dh DDDR D Port Direction

Bit	7	6	5	4	3	2	1	0
R								
W	-	-	-	-	DDDR3	DDDR2	DDDR1	DDDR0



Table 5-9. P12 010Ch DDATA D Port Data

Bit	7	6	5	4	3	2	1	0
R	-	-	-	-	DDATA3	DDATA2	DDATA1	DDATA0
W	-	-	-	-	-	-	-	-

Table 5-10. D Port Control Register Operation

DDDRn	Direction	DDATAn(Read)	DDATAn(Write)
0	Input Port	0 ; Input 'Low'	Invalid
		1 ; Input 'High'	
1	Output Port	Written Data	0 ; Output 'Low'
			1 ; Output 'High'

## 5.2 Device Initialization

Interrupt level 0 (RESET) cannot be masked and will be recognized immediately, even in the middle of an instruction. To execute the level-0 interrupt, the RESET pin must be held low for a minimum of five internal clock cycles to guarantee recognition by the device. During assertion of the RESET pin, the following operations are performed prior to the first instruction acquisition.

- 1) All zeros are written to the status register. This disables all interrupts and clears all interrupt flags.
- 2) The initialized data is written to the peripheral register.
- 3) The MSB and LSB values of the program counter just before RESET are stored in the R0 and R1 (A and B) registers, respectively.
- 4) The stack pointer is initialized to 01h.
- 5) The MSB and LSB of the reset vector are fetched from locations FFFEh and FFFFh, respectively (see Table 4-5), and located into the program counter.

## 5.3 I/O Control Registers

The I/O control registers are located in the peripheral file and are responsible for interrupt control. The DMC73C167 contains the I/O Control 0 (IOCTL0), I/O Control 1 (IOCTL1), I/O Control 2 (IOCTL2), I/O Control 3 (IOCTL3), and I/O Control 4 (IOCTL4) registers, the I/O Control registers are mapped into locations P0 (IOCTL0), P1 (IOCTL1), P2 (IOCTL2), P3



(IOCTL3), and P4 (IOCTL4) of the peripheral file. The individual interrupt mask and resets are controlled through these registers. The interrupt sources may also be individually tested by reading the interrupt flags or corresponding input ports. The INTn FLAG values are independent of the INTn ENABLE values. Writing a 1 to the INTn CLEAR bit will clear the corresponding INTn FLAG, but writing 0 to the INTn CLEAR bit has no effect on the bit.

For INTn to be recognized by the CPU, three conditions must be met.

- 1) A 1 must be written to the INTn ENABLE bit in the IOCTL0, IOCTL1, IOCTL3, or IOCTL4 register.
- 2) The global INTERRUPT ENABLE bit, that is bit 4 in the status register, must be set to 1 by the EINT instruction.
- 3) INTn must be the highest priority interrupt asserted within an instruction boundary.

Table 5-11. Interrupt Control Registers

P0 0100h IOCTL0 Interrupt Control 0								
Bit	7	6	5	4	3	2	1	0
R	0	0	INT3F	INT3E	INT2F	INT2E	INT1F	INT1E
W							INT1CLR	

P0 0101h IOCTL1 Interrupt Control 1								
Bit	7	6	5	4	3	2	1	0
R	Not used				INT5F	INT5E	INT4F	INT4E
W							INT4CLR	

P0 0102h IOCTL2 Interrupt Control 2								
Bit	7	6	5	4	3	2	1	0
R	Not used					INT3_0	INT1	INT5_0
W						EDGE	EDGE	EDGE

P0 0103h IOCTL3 Interrupt Control 3								
Bit	7	6	5	4	3	2	1	0
R	INT3_1F	INT3_1E	INT3_0F	INT3_0E	INT2_1F	INT2_1E	INT2_0F	INT2_0E
W	INT3_1C		INT3_0C		INT2_1C		INT2_0C	



		P0 0104h IOCTL4 Interrupt Control 4							
Bit		7	6	5	4	3	2	1	0
R		Not used		INT5_2F	INT5_2E	INT5_1F	INT5_1E	INT5_0F	INT5_0E
W				-		-		INT5_0C	

**Notes :**

Different names are labeled for those bits which have a different read/write operation at the same bit position in the peripheral registers.

Table 5-12. P0 0100h IOCTL0 Interrupt control 0

Bit	7	6	5	4	3	2	1	0
R	0	0	INT3F	INT3E	INT2F	INT2E	INT1F	INT1E
W							INT1CLR	
			←-----		←-----		←-----→	
			INT3 GLOBAL		INT2 GLOBAL		EXTERNAL INT1	

- Bit 0** INT1E. External Interrupt 1 Enable.  
0 = INT1 disabled  
1 = INT1 enabled
- Bit 1** INT1F. External Interrupt 1 Flag.  
0 = INT1 not requested.  
1 = INT1 pending
- Bit 2** INT2E. Interrupt 2 Enable  
Enables and disables INT2\_0 (Timer 1) and INT2\_1 (Timer 2)  
0 = Disables INT2.  
1 = Enables INT2.
- Bit 3** INT2F Interrupt 2 Flag  
Any INT2\_0 or INT2\_1 interrupt request sets this bit to 1. To clear this bit, write 1 to INT2\_0C or INT2\_1C of IOCTL3 register, the corresponding bit of interrupt requested.  
0 = INT2\_0 and INT2\_1 are not requested.  
1 = INT2\_0 or INT2\_1 is pending
- Bit 4** INT3E. Interrupt 3 Enable  
Enables and disables INT3\_0 (External) and INT3\_1 (Timer 3)  
0 = Disables INT3.  
1 = Enables INT3.
- Bit 5** INT3F. Interrupt 3 Flag  
Any INT3\_0 or INT3\_1 interrupt request sets this bit to 1. To clear this bit, write 1 to INT3\_0C or INT3\_1C of IOCTL3 register, the corresponding bit



- of interrupt requested.  
 0 = INT3\_0 and INT3\_1 are not requested.  
 1 = INT3\_0 or INT3\_1 is pending
- Bit 6** Should always be 0.  
**Bit 7** Should always be 0.

Table 5-13. P1 0101h IOCTL1 Interrupt Control 1

Bit	7	6	5	4	3	2	1	0
R	Not used				INT5F	INT5E	INT4F	INT4E
W							INT4CLR	
					← INT5 GLOBAL →		← OSD →	

- Bit 0** INT4E. OSD Interrupt (INT4) Enable.  
 0 = Disables OSD interrupt  
 1 = Enables OSD interrupt
- Bit 1** INT4F. OSD Interrupt (INT4) Flag  
 0 = INT4 is not requested.  
 1 = INT4 is pending  
 INT4CLR. Clear OSD Interrupt (INT4) Flag  
 0 = No effect  
 1 = Clears OSD interrupt INT4 flag
- Bit 2** INT5E. Interrupt 5 Enable  
 This bit enables INT5\_0, INT5\_1, and INT5\_2 interrupt requests.  
 0 = Disables Interrupt 5  
 1 = Enables Interrupt 5
- Bit 3** INT5F. Interrupt5 Flag  
 Any interrupt request of INT5\_0, INT5\_1, or INT5\_2 sets this bit to 1.  
 0 = INT5\_0 and INT5\_1 are not requested  
 1 = INT5\_0 or INT5\_1 is pending
- Bit 4-7** Not used in this device.

Table 5-14. P2 0102h IOCTL2 Interrupt Control 2

Bit	7	6	5	4	3	2	1	0
R	Not used					INT3_0	INT1	INT5_0
W						EDGE	EDGE	EDGE

- Bit 0** INT5\_0 EDGE. External Interrupt INT5\_0 Edge Selection.  
 0 = INT5\_0 interrupt is triggered at falling edge.  
 1 = INT5\_0 interrupt is triggered at rising edge.



- Bit 1** INT1 EDGE. External Interrupt INT1 Edge Selection.  
0 = INT1 interrupt is triggered at falling edge.  
1 = INT1 interrupt is triggered at rising edge.
- Bit 2** INT3\_0 EDGE. External Interrupt INT3\_0 Edge Selection.  
0 = INT3\_0 interrupt is triggered at falling edge.  
1 = INT3\_0 interrupt is triggered at rising edge.
- Bit 3-7** Not used in this device

Table 5-15. P3 0103h IOCTL3 Interrupt Control 3

Bit	7	6	5	4	3	2	1	0
R	INT3_1F	INT3_1E	INT3_0F	INT3_0E	INT2_1F	INT2_1E	INT2_0F	INT2_0E
W	INT3_1C		INT3_0C		INT2_1C		INT2_0C	
	←-----		←-----		←-----		←-----	
	TIMER 3		EXTERNAL INT3_0		TIMER 2		TIMER 1	

- Bit 0** INT2\_0E. Timer 1 (INT2\_0) Interrupt Enable  
0 = Disables Timer 1 (INT2\_0) interrupt  
1 = Enable Timer 1 (INT2\_0) interrupt
- Bit 1** INT2\_0F. Timer (INT2\_0) Interrupt Flag  
This flag sets the INT2F bit of IOCTL0 register and requests to jump to the INT2 interrupt service routine.  
0 = Timer (INT2\_0) interrupt is not requested.  
1 = Timer (INT2\_0) interrupt is pending  
INT2\_0C. Clear Timer 1 (INT2\_0) Interrupt Flag.  
0 = No effect.  
1 = Clear Timer 1 (INT2\_0) interrupt flag
- Bit 2** INT2\_1E. Timer 2 (INT2\_1) Interrupt Enable  
0 = Disables Timer 2 (INT2\_1) interrupt  
1 = Enable Timer 2 (INT2\_1) interrupt
- Bit 3** INT2\_1F. Timer 2 (INT2-1) Interrupt Flag  
This flag sets the INT2F bit of IOCTL0 register and requests to jump to the INT2 interrupt service routine.  
0 = Timer (INT2\_1) interrupt is not requested.  
1 = Timer (INT2\_1) interrupt is pending  
INT2\_1C. Clear Timer 2 (INT2\_1) Interrupt Flag.  
0 = No effect.  
1 = Clear Timer 2 (INT2\_1) interrupt flag
- Bit 4** INT3\_0E. External Interrupt INT3\_0 Enable  
0 = Disables INT3\_0 interrupt  
1 = Enable INT3\_0 interrupt





- Bit 5** INT3\_0F. External Interrupt INT3\_0 Flag.  
This flag sets the INT3F bit of IOCTL0 register and requests to jump to the INT3 interrupt service routine.  
0 = INT3\_0 interrupt is not requested.  
1 = INT3\_0 interrupt is pending  
INT3\_0C. Clear INT3\_0 Interrupt Flag.  
0 = No effect.  
1 = Clear INT3\_0 interrupt flag
- Bit 6** INT3\_1F Timer 3 (INT3-1) Interrupt Enable.  
0 = Disables Timer 3 (INT3\_1) interrupt  
1 = Enable Timer 3 (INT3\_1) interrupt
- Bit 7** INT3\_1F. External Interrupt INT3\_1 Flag.  
This flag sets the INT3F bit of IOCTL0 register and requests to jump to the INT3 interrupt service routine.  
0 = Timer 3 (INT3\_1) interrupt is not requested.  
1 = Timer 3 (INT3\_1) interrupt is pending  
INT3\_1C. Clear Timer 3 (INT3\_1) Interrupt Flag.  
0 = No effect.  
1 = Clear Timer 3 (INT3\_1) interrupt flag

Table 5-16. P4 0104h Interrupt Control 4

Bit	7	6	5	4	3	2	1	0
R	Not used		INT5_2F	INT5_2E	INT5_1F	INT5_1E	INT5_0F	INT5_0E
W			-		-		INT5_0C	

I2C SLAVE
I2C MASTER
EXTERNAL INT

- Bit 0** INT5\_0E. External Interrupt 5\_0 Enable  
0 = Disables INT5\_0 interrupt  
1 = Enable INT5\_0 interrupt
- Bit 1** INT5\_0F. External Interrupt 5\_0 Flag  
This flag sets the INT5F bit of IOCTL1 register and requests to jump to the INT5 interrupt service routine.  
0 = INT5\_0 interrupt is not requested.  
1 = INT5\_0 interrupt is pending  
INT5\_0C. Clear Interrupt 5\_0 Flag  
0 = No effect.  
1 = Clear INT5\_0 interrupt flag
- Bit 2** INT5\_1E. I2C MASTER Interrupt 5\_1 Flag  
0 = Disables I2C MASTER INT5\_1 interrupt  
1 = Enable I2C MASTER INT5\_1 interrupt

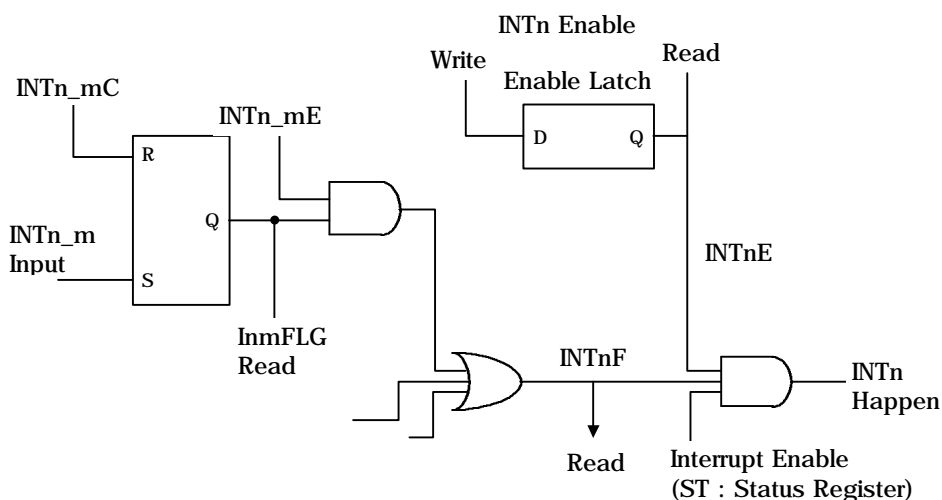


- Bit 3** INT5\_1F. I2C MASTER Interrupt 5\_1 Flag.  
This flag sets the INT5F bit of IOCTL1 register and requests to jump to the INT5 interrupt service routine. INT5\_1F is cleared when 1 is written to the INT5\_1C bit of the I2C MSTS register (P50.7).  
0 = I2C MASTER interrupt (INT5\_1) is not requested.  
1 = I2C MASTER interrupt (INT5\_1) is pending.  
Note : See I2C master status register MSTS for details.
- Bit 4** INT5\_2E. I2C SLAVE Interrupt 5\_2 Enable  
0 = Disables I2C SLAVE Interrupt (INT5\_2).  
1 = Enable I2C MASTER Interrupt (INT5\_2)
- Bit 5** INT5\_2F. I2C SLAVE Interrupt 5\_2 Flag  
This flag sets the INT5F bit of IOCTL1 register and requests to jump to the INT5 interrupt service routine. INT5\_2F is cleared when 1 is written to the INT5\_2C bit of the SCTL register (P56.0).  
0 = I2C SLAVE Interrupt (INT5\_2) is not requested.  
1 = I2C SLAVE Interrupt (INT5\_2) is pending
- Bit 6, 7** Not used in this device.

#### 5.4 Interrupt Logic and External Interrupt

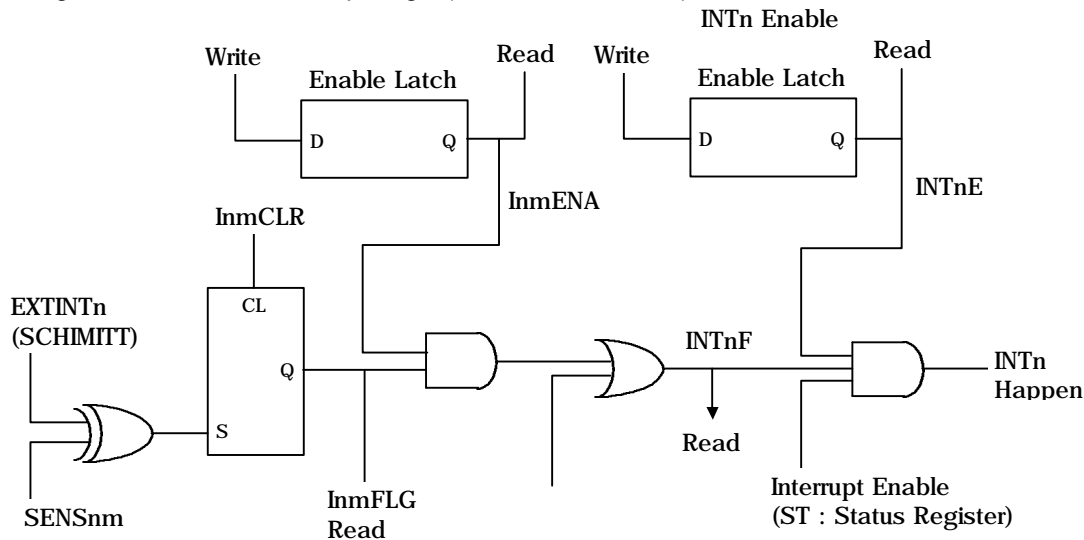
The internal interrupt logic for each of the five maskable interrupts for the DMC73C167 is shown in Figures 5-1 and 5-2 below. This interrupt logic will detect the output of each corresponding interrupt.

Figure 5-1. Interrupt Logic ( $n = 2$  or  $4$ ;  $m = 0$  or  $1$ )



The interrupt flag (INTn\_mF) is set to 1 by the INTn\_m input. The INTnF flag becomes active when INTnE is 1, then INTn occurs if the interrupt enable bit (I bit) of the status register is set to 1.

Figure 5-2. External Interrupt Logic (n = 1, 3 or 5 ; m = 0)



To conserve the low power requirement, one low-power mode - the HALT MODE - is provided. It is invoked by executing an IDLE instruction. An external interrupt will release the device from the low-power mode depending on whether it is in the HALTmode. When an external interrupt is first asserted, its level is gated into an interrupt flag. In order for an interrupt signal to be detected, the pulse duration must be a minimum of five internal clock cycles.

The INTn Enable bit is used separately to individually mask interrupt levels, and must be set 1 for the interrupt to be recognized.

As Previously stated, all interrupt control bits are implemented in the IOCTL0, IOCTL1, IOCTL2, IOCTL3, and IOCTL4 registers in the peripheral file. I/O instructions may simply read from and write to each INTn Enable bit. By the INTn input, the interrupt flag is set to 1 at the falling or rising edge and becomes active when an interrupt is enabled. The interrupt service routine is executed after the currently executing instruction is completed. Once the interrupt has been acknowledged by the CPU, the CPU then pushes the contents of the status register and the program counter (MSB and LSB), respectively, onto the stack and makes zero the status register (see Section 4.4). The corresponding vector address is loaded into the program counter, and the interrupt service routine is executed. The external interrupts, INT1, INT3\_0, and INT5\_0, have Schmitt-trigger inputs and can be used as zero-cross detectors.

Because the pins can be used as both external interrupt pins and general-purpose I/O pins, the following points should be noted :



- 1) The port using as the interrupt input should be in the input mode. The output mode may cause damage to the device. If the contents of the corresponding output port are changed from 1 to 0, the interrupt flag will also set to 1.
- 2) If not used as the interrupt input, the corresponding interrupt enable should be disabled. But even with the disabling of this interrupt enable, the interrupt flag will be changed.

The external interrupt timing is shown in Figure 5-6. The device needs additional circuitry when INT1, INT3\_0, and IN 5\_0 are used as zero-cross detectors as shown in Figure 5-7. The following conditions are needed :

- 1) The external interrupt level should be in the range from VCC +0.3V to VSS. The input current must not exceed the specification.
- 2) Noise on the interrupt signal should be minimized because the noise debounce logic is not implemented on chip. The function may fail due to continuous interrupts.

**Caution :**

It is possible that the INTn flag bits in the IOCNT registers could be unintentionally cleared by using bit manipulation instructions (ANDP/ORP & XORP). To avoid these occurrences, use the MOVP and STA instructions when writing Data to IOCNT registers.

Figure 5-3. External Interrupt Timing

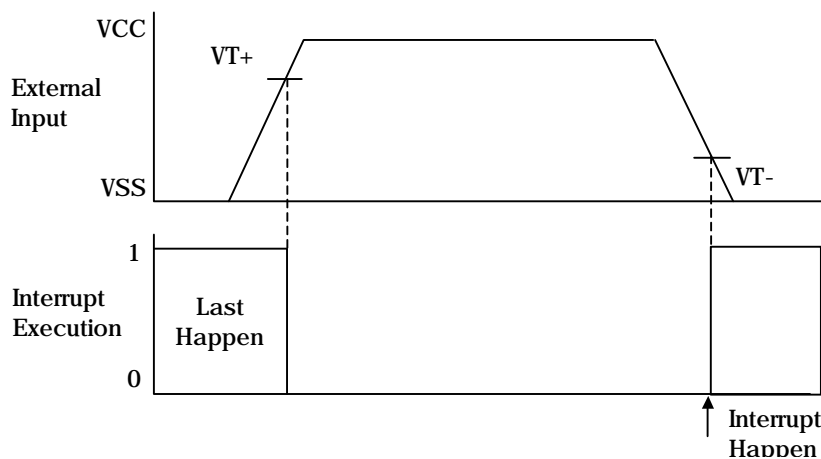
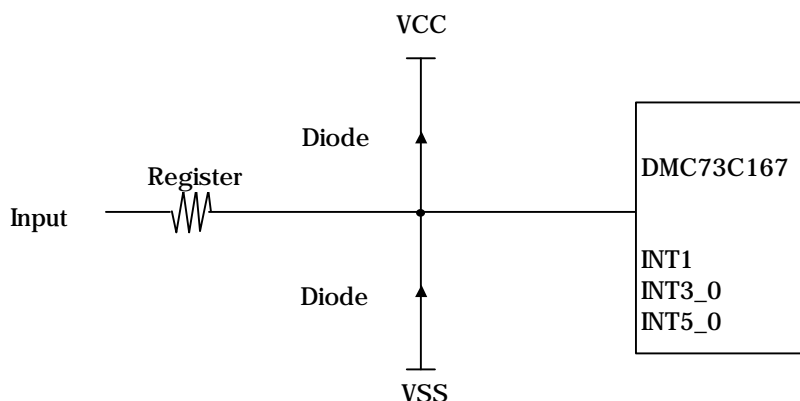


Figure 5-4. Additional Circuit for External Input



### 5.5 Programmable Timer / Event Counter

The DMC73C167 has three on-chip programmable timers with individual start/stop control bits. Timer 1 (shown in Figure 5-5) is a 16-bit timer. It has a 16-bit capture latch and a 5-bit nonreadable prescaler with a 5-bit reload register. Timer 2 and Timer 3 (shown in Figures 5-6 and 5-7) are 8-bit timers. They have an 8-bit capture latch and a 2-bit nonreadable prescaler with a 2-bit reload register.

Table 5-17. Timer Mode and Clock Sources

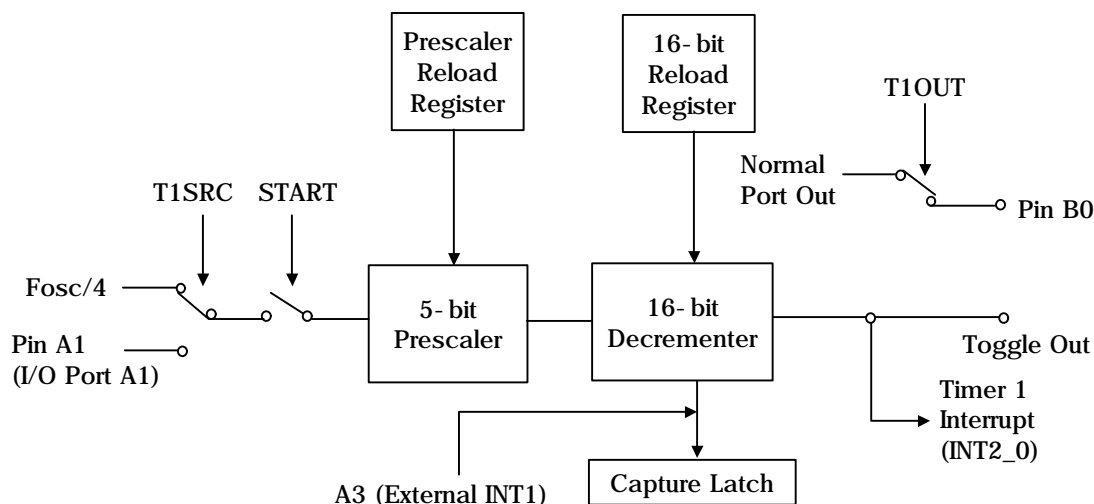
Timer	Mode	Clock Source	Capture Latch Trigger	Interrupt	Control Register
1	RTC mode	Internal Fosc/4	Port A3 (INT1)	INT2_0	T1MSD (P20) T1LSD (P21)
	Event counter mode	External port A1	active edge †		T1CTL0 (P22) T1CTL1 (P23)
2	RTC mode	Internal Fosc/4	Port A4 (INT3_0)	INT2_1	T2DATA (P24)
	Event counter mode	External port A2	active edge †		T2CTL (P25)
3	RTC mode	Internal Fosc/4	Port A5 (INT5_0)	INT3_1	T3DATA (P26)
	Cascade	Timer 2 underflow	active edge †		T3CTL (P27)

† Note : This active edge is determined by the INT1, INT3\_0, and INT5\_0 EDGE bit of the IOCTL2 (P2) register.



### 5.5.1 Timer 1

Figure 5-5. Timer 1 Schematic Diagram



Timer 1 is a 16-bit timer that contains a 5-bit prescaler and a 16-bit decremter. The clock source of Timer 1 is determined by bit 5 of T1CTL0 (T1SRC, P22.5).

Writing 0 to the T1SRC bit selects the internally generated Fosc/4 clock and places the timer/event counter in real-time clock mode. A T1SRC bit of 1 selects the external clock source and places the timer/event counter in event counter mode.

Bit 7 of the T1CTL0 register is the START bit for Timer 1. When 0 is written to the START bit, the timer chain is disabled or frozen at the current count value. When 1 is written to the START bit, regardless of whether it was previously a 0 or a 1, the prescaler and counter decremeters are loaded with the corresponding latch values and the timer/event counter operation begins.

When the prescaler and counter decremter through zero together, an interrupt flag is set, and the prescaler and counter decremeters are immediately and automatically reloaded with the corresponding latch values of the reload registers.

The interrupt level generated by Timer 1 is INT2\_0. Timer 1 has a 16-bit capture latch associated with INT1(A3) that captures the current value of the counter whenever INT1 (port A3) is activated.

#### 5.5.1.1 Timer 1 Control Registers

Table 5-18. P20 0114h T1MSD Timer 1 MSB Data

Bit	7	6	5	4	3	2	1	0
R	16-bit Timer 1 MSB Decrementer Value							
W	16-bit Timer 1 MSB Reload Register							



Table 5-19. P21 0115h T1LSD Timer 1 LSB Data

Bit	7	6	5	4	3	2	1	0
R	16-bit Timer 1 LSB Decrementer Value							
W	16-bit Timer 1 LSB Reload Register							

Table 5-20. P23 0117h T1CTL1 Timer 1 Control 1

Bit	7	6	5	4	3	2	1	0
R	MSB Capture Latch Value							
W	Invalid							

Table 5-21. P22 0116h T1CTL0 Timer 1 Control 0

Bit	7	6	5	4	3	2	1	0
R	Timer 1 LSB Capture Latch Value							
W	START	T1OUT	T1SRC	Prescaler Reload Register				

Read : Provides the LSB value of the capture register which contains the decrementer register value when INT1 was last activated.

Write : Timer 1 control as below.

- Bits 0-4** Reload the 5-bit Prescaler Reload Register
- Bit 5** T1SRC. Select Timer 1 Clock Source.  
0 = Internal clock ( $F_{osc}/4$ ).  
1 = External clock from Port A1.
- Bit 6** T1OUT. Timer 1 Toggle Output  
0 = Normal output on Port B0.  
1 = Toggle output on Port B0 when the Timer 1 MSB decrementer passes through zero.
- Bit 7** START. Timer 1 Start/Stop Control  
0 = Stops Timer 1  
1 = Starts Timer 1

### 5.5.1.2 Real-Time Clock Mode (RTC)

In real-time clock mode, the internal  $F_{osc}/4$  is the prescaler clock source. Each positive pulse transition of the  $F_{osc}/4$  period signal decrements the count chain.

### 5.5.1.3 Event Counter Mode (EC)

When Timer 1 is in event counter mode, port A1 is the clock source for Timer 1. The maximum clock frequency on A1 at the event counter mode must not be greater than  $F_{osc}/4$ . The minimum pulse width must not be less than  $2/F_{osc}$ . Each positive pulse Transition decrements the counter chain.

### 5.5.1.4 Timer 1 Interrupt Period

The period of the timer INT2\_0 interrupt can be calculated as follows.

$$t_{INT} = t_{CLK} \times (PL + 1) \times (TL + 1)$$

where :

$t_{INT}$  = period of timer interrupt

$t_{CLK}$  =  $4/F_{osc}$ . for the internal real-time clock mode or the period of the input clock source at the external EC mode

PL = Prescaler latch value (00h-1Fh : 5-bit)

TL = Decrementer reload value (0000h-FFFFh : 16-bit)

Example        min : 1us  
( $F_{osc}$  : 4MHz) max : 2.097 sec

### 5.5.1.5 Capture Latch

The current value of the decremter is stored in the capture latch register at the active edge of Port A3. The active edge is determined by the INT-1 EDGE bit of the IOCTL2 (P2.1) register. The capture latch is disabled during the IDLE instruction.

### 5.5.1.6 Timer Output Function

A timer output function exists on Timer 1 that allows the B0 output to be toggled every timer decrements through zero. This function is enabled by the T1OUT bit of the timer control register (T1CTL0.6). When operating in the timer output mode, the B0 output cannot be changed by writing to the B port data register. Writing to the timer's START bit will reload and start the timer but will not toggle the output. The output will toggle only when the timer decrements through zero. The timer output feature is independent INT2\_0 and therefore will operate whether or not INT2\_0 is enabled.

Whenever the T1OUT bit is returned to 0, B0 will become the normal output port. The value in the B0 data register will be the last value output by the timer output function, and the CPU can control the B0 data.



### 5.5.1.7 Notes on Timer Usage

In Timer 1, the most significant byte (MSB) read-out latch is shared between the MSB of the decremter and the MSB of the capture latch to be sampled at one moment. The Timer 1 MSB read-out latch can be read from both P20 and P23. Reading the LSB of the decremter or capture latch will always update the contents of the read-out latch. In order to read correctly the entire 16-bit value of the decremter or capture latch, the LSB must be read first, which will load the MSB read-out latch. The MSB read-out latch must be read and stored after reading the LSB of either the decremter or capture latch.

### 5.5.2 Timer 2 / Timer 3

Timer 2 and Timer 3 are 8-bit timers that contain a 2-bit prescaler and an 8-bit decremter. The clock source of Timer 2 is determined by the T2SRC bit of the T2CTL register (P25.5), and the clock source of Timer 3 determined by the T3SRC bit of the T3CTL register (P27.6). Setting the T2SRC or T3SRC bits to 0 selects the internally generated Fosc/4 clock and places the timer in real-time clock mode. Setting the T2SRC bit to 1 selects the external clock source and places Timer 2 in event counter mode. Setting the T3SRC bit to 1 selects the Timer 2 underflow for the Timer 3 clock source, and makes Timer 2 and Timer 3 cascadable. When 0 is written to the START bit, the timer chain is disabled or frozen at the current count value. When 1 is written to the START bit, regardless of whether it was previously a 0 or a 1, the prescaler and counter decremters are loaded with the corresponding latch values, and the timer/event counter operation begins.

When the prescaler and counter decremter through zero together, an interrupt flag is set, and the prescaler and counter decremters are immediately and automatically reloaded with the corresponding latch values.

The interrupt levels generated by the timers are INT2\_1 for Timer 2 and INT3\_1 for Timer 3. Timer 2 and Timer 3 each have a respective associated 8-bit capture latch that captures the current value of the counter whenever 8-bit capture latch that captures the current value of the counter whenever Port A4 (INT3\_0) for Timer 2 or Port A5 (INT5\_0) for Timer 3 are activated.

Figure 5-6. Timer 2 Block Diagram

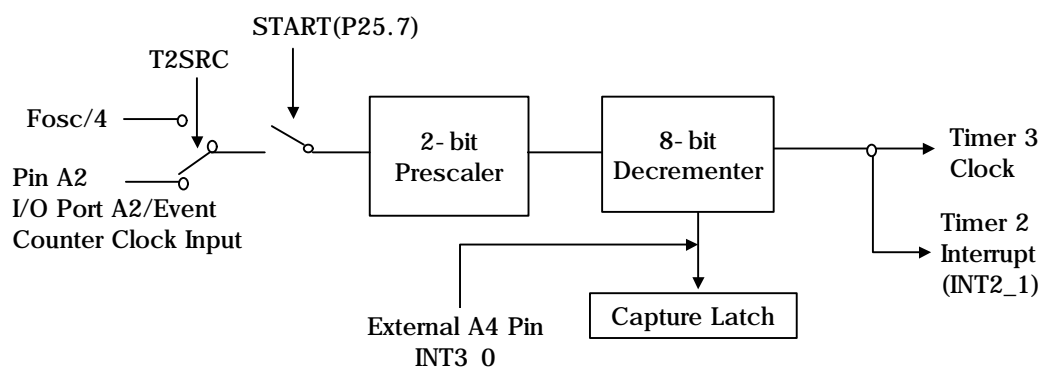
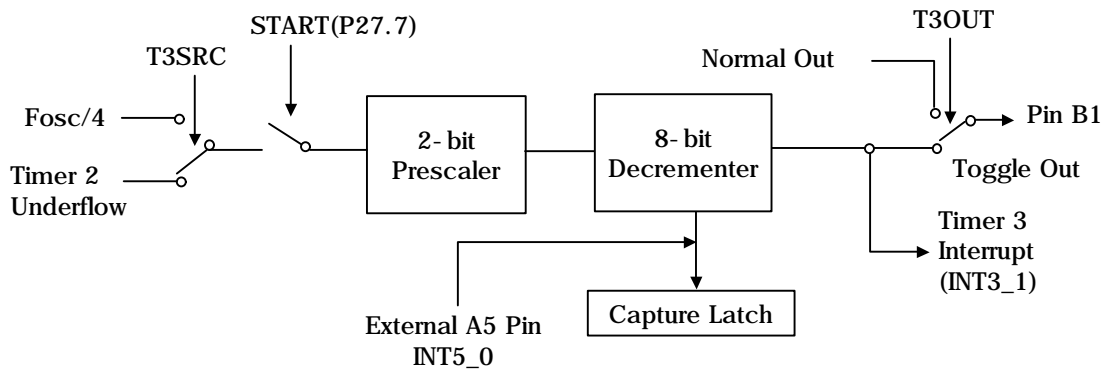


Figure 5-7. Timer 3 Block Diagram



5.5.2.1 Timer 2 and Timer 3 Control Registers

Table 5-22. P24 0118h T2DATA Timer 2 Data

Bit	7	6	5	4	3	2	1	0
R	8-bit Timer Decrementer Value							
W	8-bit Timer Reload Register							

Table 5-23. P25 0119h T2CTL Timer 2 Control

Bit	7	6	5	4	3	2	1	0
R	Capture Latch Value							
W	START	T3OUT	T2SRC	Not Used			Prescaler Reload	

Read : Provides the value of the capture register which contains the latched value of the decremter register when INT3\_0 was first activated.

Write : Timer 2 control as below.

**Bits 0, 1** Reload the 2-bit Prescaler Reload Register.

**Bits 2-4** Not used.

**Bit 5** T2SRC. Select Timer 2 Clock Source.

0 = Internal clock (Fosc/4).

1 = External clock from Port A2.

**Bit 6** TOUT. Timer 3 Toggle Output.

0 = Normal output on Port B1.

1 = Toggled output on Port B1 when the Timer 3 MSB decremter passes through zero

- Bit 7** START. Timer 2 Start/stop Control  
 0 = Stops Timer 2.  
 1 = Starts Timer 2.

Table 5-24. P26 011Ah T3DATA Timer 3 Data

Bit	7	6	5	4	3	2	1	0
R	8-bit Timer Decrementer Value							
W	8-bit Timer Reload Register							

Table 5-25. P27 011Bh T3CTL1 Timer 3 Control

Bit	7	6	5	4	3	2	1	0
R	Capture Latch Value							
W	START	T3SRC	Not Used				Prescaler Reload	

Read : Provides the value of the capture register which contains the latched value of the decremter register when INT3\_0 was most recently activated.

Write : Timer 3 control as below.

- Bits 0, 1** Rescaler Road. Reload the 2-bit Prescaler Reload Register.  
**Bits 2-5** Not used.  
**Bit 6** T3SRC. Select Timer 3 Clock Source.  
 0 = Internal clock ( $F_{osc}/4$ ).  
 1 = Timer 2 underflow (Cascade mode)  
**Bit 7** START. Timer 3 Start/stop Control  
 0 = Stops Timer 3.  
 1 = Starts Timer 3.

### 5.5.2.2 Real-Time Clock (RTC)

In real-time clock mode, the internal  $F_{osc}/4$  is the decremter clock source. Each positive pulse transition of the  $F_{osc}/4$  period signal decrements the counter chain.

### 5.5.2.3 Event Counter (EC)

When Timer 2 is in event counter mode, port A2 (ECI2) is the decremter clock source for Timer 2. The maximum clock frequency on A2 in event counter mode must not be greater than  $F_{osc}/4$ . The minimum pulse duration must not be less than  $2/F_{osc}$ . Each positive pulse transition decrements the counter chain. It is not possible for Timer 3 to be in event counter mode.



### 5.5.2.4 Timer 2 and Timer 3 Interrupt Period

The Period of the timer interrupts INT2\_1 and INT3\_1 can be calculated as follows.

$$t_{INT} = t_{CLK} \times (PL + 1) \times (TL + 1)$$

where :

$t_{INT}$  = period of timer interrupt

$t_{CLK}$  =  $4/F_{osc}$ . for the internal real-time clock mode or the period of the input clock source at the external EC mode

PL = Prescaler latch value (0h-3h : 2bit)

TL = Decrementer reload value (00h-FFh : 8bit)

- In case of not cascade (INT2\_1 and INT3\_1)

Example :           min : 1us  
(CPUCLK : 4MHz)   max : 1.024ms

- In case of Timer 2 and Timer 3 cascade (INT3\_1)

Example :           min : 1us  
(CPUCLK : 4MHz)   max : 1.048sec.

### 5.5.2.5 Capture Latch

The current value of the decremter is stored in the capture latch register at the active edge of port A4 (INT3\_0) for Timer 2 and port A5 (INT5\_0) for Timer 3. The active edge is determined by the INT3\_0 EDGE and INT5\_0 EDGE bits of the IOCTL2 register (P2). The capture latch register is disabled during the IDLE instruction.

### 5.5.2.6 Timer Output Function

A timer output function exists on Timer 3 that allows the B1 output to be toggled every time the timer decrements through zero. This function is enabled by the T3OUT bit of the T2CTL register (P25.6). When operating in the timer output mode, the B1 output cannot be changed by writing to the B port data register. Writing to the timer's START bit will reload and start the timer but will not toggle the output. The output will toggle only when the timer decrements through zero. The timer output feature is independent of INT3\_1 and therefore will operate whether INT3\_1 enabled or not.

Whenever the T3OUT bit is returned to 0, B1 will become the normal output port. The value in the B1 data register will be the last value output by the timer output function, and the CPU can control the B1 data.



### 5.5.3 Warming-up Timer

A 14-bit counter (P33, P34) is used as a warming-up delay timer which supplies a stable oscillation condition from the system halt mode. The system clock cannot be active before the warming-up counter's underflow.  $F_{osc}/2$  (system clock frequency) is the decremter clock source of the 14-bit warm-up counter. The delay time is programmable by changing P33 (the 6-bit MS value) and P34 (the 8-bit LS value).

#### Caution :

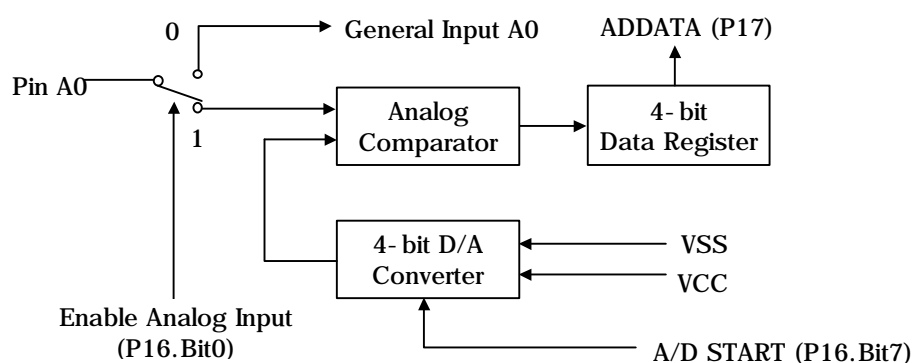
Set P35 to 0 before executing the IDLE instruction to avoid the unreliable setting of the warming-up timer value.

### 5.6 A/D Converter

The key features of the A/D converter are as follows.

Analog input	: 1 channel (A0)
Analog input range	: VCC to VSS
Conversion	: Successive approximation conversion
Resolution	: 4 bit
Conversion time	:40 machine cycle

Figure 5-8. A/D Converter Function Diagram



#### 5.6.1 Reference Values of A/D Conversion

The reference values of ADDATA are listed below. VSS and VCC are assumed to be 0 and +5V, respectively.



ADDATA	Voltage Ranges (V)	ADDATA	Voltage Ranges (V)
0	0.0000-0.1562	8	2.3437-2.6562
1	0.1562-0.4687	9	2.6562-2.9687
2	0.4687-0.7812	10	2.9687-3.2812
3	0.7812-1.0937	11	3.2812-3.5937
4	1.0937-1.4062	12	3.5937-3.9062
5	1.4062-1.7187	13	3.9062-4.2187
6	1.7187-2.0312	14	4.2187-4.5312
7	2.0312-2.3437	15	4.5312-5.0

### 5.6.2. A/D Converter Control / Data Registers

The specifications of the A/D converter control and data registers are shown as follows.

Table 5-26. P16 011h ADCTL A/D Control

Bit	7	6	5	4	3	2	1	0
R	START	0	0	0	0	0	0	ADENA
W								

**Bit 0** ADENA. Enable Analog Input

The ADENA control bit configures port A0 as either an analog input channel or a logic input channel. When the bit is set to 1, port A0 can be enabled for analog signal input. When the bit is set to 0, port A0 can be enabled for logic level input.

0 = Pin A0 is a digital input port

1 = Pin A0 is an analog input port.

Note : Before the A/D converter operation starts, the ADENA bit should be set to 1.

**Bit 1-6** Should be set to 0.

**Bit 7** START. A/D Converter Start/Stop Control Bit.

0 = Stops A/D Converter

1 = Starts A/D Converter



Table 5-27. P17 0111h ADDATA A/D Conversion Data

Bit	7	6	5	4	3	2	1	0
R	Not used				A/D Conversion Data			
W	Invalid							

**Bit 0-3** A/D Conversion Data

4-bit A/D conversion data is retrieved by the read operation.  
The write operation is not available through this register.

**Bit 4-7** Not used.

### 5.6.3 A/D Converter Operation

The A/D converter operation procedure is as follows.

- 1) Turn on the 14-bit PWM.
- 2) Set the ADENA bit (ADCTL register bit 0) to 1.
- 3) Set the START (ADCTL register bit 7) to 1. Then A/D conversion starts.
- 4) The conversion data is transferred to the ADDATA register after A/D conversion is completed. It takes 40 machine cycles.
- 5) The ADDATA register can be read. If the START bit is set to 0 during A/D conversion, the A/D converter operation is terminated after A/D conversion is completed. This timing is shown in Figure 5-9 for single conversion and Figure 5-10 for continuous conversion. There is no status flag, so user should wait 40 machine cycles.

#### Attention :

The 14-bit PWM should be running before turning on the A/D conversion.



Figure 5-9. Single A/D Conversion.

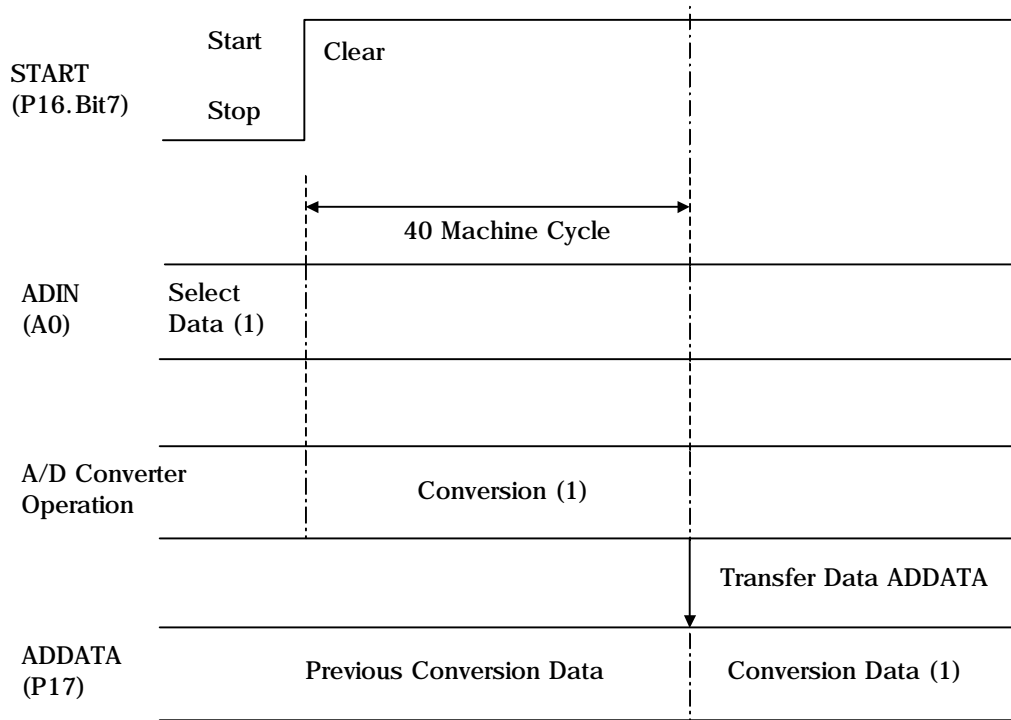
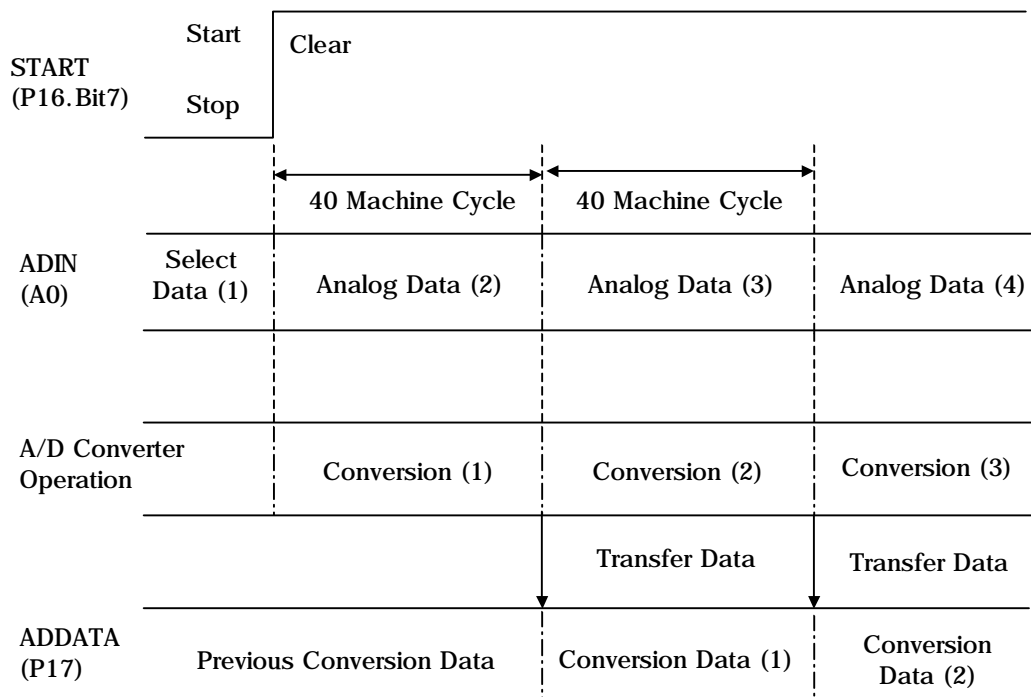


Figure 5-10. Continuous A/D Conversion.





### 5.7 I2C

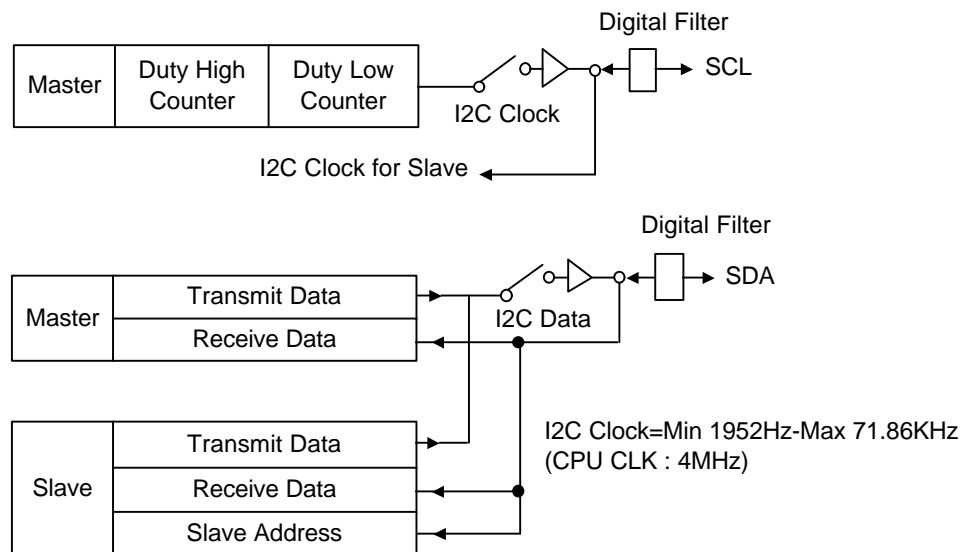
The DMC73C167 contains a I2C master/slave transceiver hardware interface. The I2C bus is a serial communication system, and requires serial data SDA and an associated data clock SCL. As the chip is fully programmable by software, it can be used for master mode, slave mode, and/or multi-master mode operations. Both the SCL and SDA pins are input and open-drain output pins.

For the DMC73C167, the slave address is as follows.

A6	A5	A4	A3	A2	A1	A0	R/W
0	1	1	0	1	A1	A0	

The hardware (pin) programmable address bits are A1 and A0.

Figure 5-11 I2C Block Diagram



Note : SDA, SCL = Open drain output, Schmitt input



## 5.7.1 Master Mode

### 5.7.1.1 Master Control Register

Table 5-28. P48 013h MCTL0 I2C Master Control 0

Bit	7	6	5	4	3	2	1	0
RW	ACT	-	RSRT	LODUTY	MDIR	NACK	BCM1	BCM0

- Bit 7** ACT. Activation of Start Condition (R/W)  
On hardware reset, this bit will be 0. But just after this bit is set to 1, actual transfer will start. Therefore, before writing 1 to this bit, MSTS, MDATA, HDC, and LDC should be initialized first. As soon as the start condition is generated, the ACT bit will be cleared automatically.
- Bit 5** RSRT. Restart (R/W)  
A data transfer is always terminated by a stop condition generated by the master. However, if a master still wants to communicate on the bus or change the data transfer direction, it can generate another start condition and address the new slave without first generating a stop condition. To do this, the bit can be set after keeping the following settings for more than 4 $\mu$ s: ACT=0, BCM1=0, and BCM0=0. This bit will be reset automatically just after the restart action is triggered.
- Bit 4** LODUTY. Low-Duty Output (R/W)  
0 = SCL (Serial clock) duty is dependent on the contents of the HDC and LDC values.  
1 = Enlarges the low duration time by three times the LDC value.  
For example, if HDC:LDC=1:1, the SCL duty will be 1:3 if the LODUTY bit is set.
- Bit 3** MDIR. Master Data Direction (R/W)  
0 = Transmits data to the slave device. The contents of MDATA will be loaded onto the SDA line.  
1 = Receives data from the slave device. The data from the SDA line will be stored in the MDATA register. Regardless of the MDIR bit, the address data is always transmitted to the SDA line by internal hardware.
- Bit 2** NACK. No Generation of Acknowledgement (R/W)  
A master receiver must signal the last data transfer cycle or the end of the data transfer to the slave transmitter by not generating an acknowledgement on the last byte clocked from the slave. Then the slave transmitter will release the data line to allow the master to generate the stop condition.  
0 = Generates an acknowledgement after one byte has been received.  
1 = Does not generate and acknowledgement after one byte has been received.



**Bit 1, 0** BCM 1,0 . Bus Mode 1 and Mode 0 (R/W)  
When ACT = 1, these bit will be decoded as follows.

BCM1	BCM0	
0	0	1 byte data transfer with every ACT = 1
1	0	Address output with start condition to salve.
0	1	Stop condition will be generated (no data transfer).
1	1	Prohibited for any case.

Table 5-29. P49 0131th MCTL1 I2C Master Control 1

Bit	7	6	5	4	3	2	1	0
R	ENABLE	X	X	X	X	SCLP	SCLSDA	X
W		0	0	0	0	0	0	0

**Bit 7** ENABLE. Enables I2C Master Hardware (R/W)  
0 = Stops I2C master hardware. This is same as H/W reset for I2C master module.  
1 = Starts I2C master hardware.

**Bit 2** SCLP (READ). SCL Port Input Data of I2C Bus.  
0 = Logic low (0) level of SCL port.  
1 = Logic high (1) level of SCL port.

**Bit 1** SCLSDA (READ).  
NAND gate buffered data of SCL, SDA port.  
0 = Both SCL and SDA ports at high levels.  
1 = At least one of SCL or SDA is at low level.

**Bit 6-0** (WRITE). These bits should always be zero.

**Note** : In the multi-master mode, the ENABLE bit should be set to 1 before the start condition comes up from another master device.

Table 5-30. P57 0139h DFCTL I2C Digital Filter Control

Bit	7	6	5	4	3	2	1	0
R	DFON	0	Not Used					

**Bit 7** DFON. Digital Filter Control ON (R/W)  
Narrow pulses on the SDA and SCL lines are rejected when the DFON bit is set to 1.  
This bit is commonly used for master and slave operations.  
0 = Digital Filtering Off.  
1 = Digital Filtering On.

**Note** : Do not set the DFON bit to 1 if the higher period of the SCL is less than 8us  
(Spec: min 4us + Filter; max 4us). Please set to "0" for normal usage.



**Bit 6-0 Reserved.** These bit should always be zero.

Table 5-31. P50 0132h MSTS I2C Master Status

Bit	7	6	5	4	3	2	1	0
R	INT5_1F	AHOST	BERR	BBUSY	Not Used			
W	INT5_1C	CLOST	CBERR	-	Not Used			

- Bit 7** INT5\_1F. I2C Master Interrupt (INT5\_1) Flag. (READ)  
 After every action is completed, this bit will be set and INT5\_1 interrupt is requested if it is enabled. This bit is set on the following condition and reset by writing 1 to INT5\_1C. In order to proceed to the next sequence, this bit must be cleared first by writing 1 to the INT5\_1C bit.
- When completed to output address data on I2C.
  - 1 byte of data is transferred.
- After generation of stop condition.
- When there is a I2C bus error or arbitration is lost.
- INT5\_1C. Clear I2C Master Interrupt (INT5\_1) Flag. (WRITE)  
 0 = No effect.  
 1 = Clears I2C master interrupt (INT5\_1) flag.
- Bit 6** AHOST. Bus Arbitration Lost. (READ)  
 When a transfer is initiated while the I2C bus is busy, AHOST will be set, and the transfer will be canceled. If the master loses arbitration during the addressing or data transfer stages, it will stop the SDA line drive and set the AHOST bit.
- 0 = Normal operation.
  - 1 = Bus arbitration is lost.
- CLOST. Clear Arbitration Lost Flag. (WRITE)  
 0 = No effect.  
 1 = Clears arbitration lost flag.
- Bit 5** BERR. Bus Error. (READ)  
 During a data transmission or address cycle, a no acknowledgement response will set this bit.
- 0 = Normal operation.
  - 1 = A bus error has occurred.
- CBERR. Clear Bus Error Flag. (WRITE)  
 During a data transmission or address cycle, a no acknowledgement response will
- 0 = No effected.
  - 1 = Clears bus error flag.
- Bit 4** BBUSY. Bus Busy. (READ)  
 A start condition will set this bit, and a stop condition or master reset will clear it.
- 0 = I2C bus is idle.
  - 1 = I2C bus is either busy internally or being used by another master device.



Table 5-32. P51 0133h MDATA I2C Master Data

Bit	7	6	5	4	3	2	1	0
R	Master Receive Data							
W	Master Receive Data							

**Bit 7-0** MDATA. 8-Bit Parallel Read/Write Shift Register.

The receiving data will be read every time INT5\_IF=1. Afterwards, the INT5\_1F flag should be cleared. The transmitting data will be written every time INT5\_1F=1. Afterwards, the INT5\_1F flag should be cleared.

Table 5-33. P52 0134h HDC I2C Master High Duration

Bit	7	6	5	4	3	2	1	0
R	SCL High Duration Value							
W	SCL High Duration Value							

Table 5-34. P53 0135h LDC I2C Master Low Duration

Bit	7	6	5	4	3	2	1	0
R	SCL Low Duration Value							
W	SCL Low Duration Value							

HDC and LDC. SCL High and Low Duration Counters.

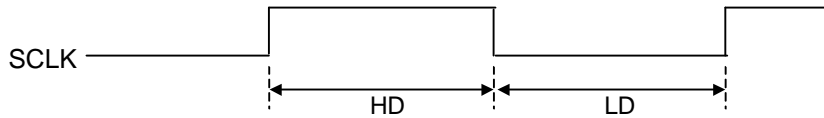
These are 8-bit registers for SCL frequency control. By changing the contents of these registers, the serial clock frequency (SCL) can be changed. High or low duration can be calculated by the following equations.

$$\text{High Duration} = \frac{4 \times (\text{FFh} - \text{Value of HDC}) + 8}{\text{Fosc (OSC frequency of CPU)}} \text{ US}$$

$$\text{Low Duration (LODUTY = 0)} = \frac{4 \times (\text{FFh} - \text{Value of LDC}) + 8}{\text{Fosc (OSC frequency of CPU)}} \text{ US}$$

$$\text{Low Duration (LODUTY = 1)} = \frac{3 \times 4 (\text{FFh} - \text{Value of LDC}) + 8}{\text{Fosc (OSC frequency of CPU)}} \text{ US}$$





Calculation example of SCL clock speed (Fosc:4MHz)

- (1) `MOV P, %F9h, HDC`  
 $FFh - F9h = 6$   
 $(4 \times 6 + 8) / 4 = 8$       so high duration will be 8us
- (2) `MOV P, %F9h, LDC`  
 $FFh - F9h = 6$   
 $(4 \times 6 + 8) / 4 = 8$       so low duration will be 8us; but if DTY = 1, low duration will be 20us

#### Notes:

- 1) By calculation, any value can be selected except the following two values: FFh, FEh (by design specifications).
- 2) The I2C bus minimum timing specification must be kept. The minimum high/low duration is 4.0/4.7us, respectively.
- 3) The digital filter is contained for special user. Please set "0" for normal usage.
- 4) The HDC (P52) and LDC (P53) registers are not able to be read from and written to if the ENABLE bit (P49, bit 7) is not set to 1.

#### 5.7.1.2 Master Mode Operation

Any transfer will begin with a start condition and terminate with a stop condition. After the start condition is generated, a slave address (the contents of MDATA) is sent. This address is 8 bits long. Bit 0 indicates the data direction: 0 = write to slave and 1 = read from slave. Following the address, 8-bit data is transferred as required and then terminated by a stop condition generated by the master. However, if the master still wants to communicate on the bus, it can generate another start condition and address another slave without generating a stop condition (restart condition). Various combinations of read/write formats are then possible within such a transfer. On the DMC73C167, a hardware reset clears all bits of the master control and status registers. To start data transfer, HDC and LDC must be set with the desired value, and the ENABLE bit must be set to 1. The following are I2C master mode control examples of data transfer operations.

Objective:

Send immediate hex data to Slave A: 88h, AAh



Read two byte data from Slave B

Slave A address (0010001)

Slave B address (1010000)

a) Initialization of HDC/LDC, MCTL, and MDATA (Fosc.-4MHz)

MDVP	%>80, MCTL1	Master I2C hardware on; power-on reset routine
MDVP	%>F9, HDC	High duration will be 8us
MDVP	%>F9, LDC	Low duration will be 8us
MDVP	%E0, MSTS	Clear MSTS register
MDVP	%?00100010, MDATA	Address out to Slave A (write data to Slave A)
MDVP	%?10100001, MDATA	Address out to Slave B (read data from Slave B)

b) Start condition generation and address transfer

For start condition, set BCM1 (=1), BCM0 (=0) of MCTL0. The next data transfer cycle is for write, so clear bit 3 (MDIR). To enable the start action, set ACT bit (bit 7 of MCTL0).

MDVP	%?10000010, MCTL0	(ACT/-	/RSRT	/LODUTY	/MDIR	/NACK	/BCM	/BCMD)
		1	0	0	0	0	1	0

After this instruction is executed, the I2C bus module will generate the start condition and transfer 7 bits of address and 1 bit of direction information. After the address cycle is completed, the I2C bus module will interrupt the CPU. But if the CPU masks the interrupt, the CPU must poll bit 7 (INT5\_1F) of MSTS to check the address transfer status.

c) Check status register (MSTS)

If the address transfer is completed successfully, the contents of MSTS will be 1001 ---- (INT5\_1F/ALOST/BERR/BBUSY/-). Then the INT5\_1F bit should be cleared before the next transfer.



## 8Bit Single Chip Microcontroller

DMC73C167

MDVP %?10000000, MSTS	(BBUSY bit has not been touched)
-----------------------	----------------------------------

d) Write transfer (two byte data)

MDVP %>88, MDATA	Frist byte of data to be sent							
MDVP %?10000000, MCTL0	(ACT/-	/RSRT	/LODUTY	/MDIR	/NACK	/BCM1	/BCMD)	
	1	0	0	0	0	0	0	

After the interrupt or polling check of the INT5\_1F bit, clear it by writing 1 to the INT5\_1C bit.

MDVP %?10000000, MSTS	Clear INT5_1F bit							
MDVP %>AA, MDATA	Second byte of data to be sent							
MDVP %?10000000, MCTL0	(ACT/-	/RSRT	/LODUTY	/MDIR	/NACK	/BCM1	/BCMD)	
	1	0	0	0	0	0	0	

After the interrupt or polling check of the INT5\_1F bit, clear the INT5\_1F bit.

MOVP %?10000000, MSTS	(Clears INT5_1F bit)
-----------------------	----------------------

e) Start condition generation and address transfer

To change the transfer direction or slave, a new cycle must be executed after the current cycle is completed by generating a stop condition or invoking another start condition. To generate another start condition, the RSRT and BCM1 bits of MCTL0 should be set after a 4us delay to keep the set up time of the start condition.

The next data transfer cycle is for read, so reset bit 3 (MDIR). To enable the start action, set bit 7 (ACT) of MCTL0.

MDVP %?10100001, MDATA	Reads data from Slave B							
MDVP %?00100000, MCTL0	Second byte of data to be sent							
	(ACT/-	/RSRT	/LODUTY	/MDIR	/NACK	/BCM1	/BCMD)	
	0	1	0	0	0	0	0	
WAITP BTJOP %?00000010, NOP NOP	MCTL1 Waits until I2C bus if free One NOP will produce a 2.0 us delay							
MDVP %>10100010, MCTL0	(ACT/-	/RSRT	/LODUTY	/MDIR	/NACK	/BCM1	/BCMD)	
	1	1	0	0	0	1	0	

After this instruction is executed, the I2C bus module will generate a start condition and transfer 7 bit of address and 1 bit of direction information. After the address





cycle is completed, the I2C bus module will interrupt the CPU. But if the CPU masks the interrupt, the following instruction can be used instead of the interrupt.

<b>LOOP BTJZP %&gt;80, MSTS, LOOP</b>	<b>Repeats LOOP until INT5_1F is set</b>
---------------------------------------	--

f) Clear INT5\_1F bit and one byte read

<b>MDVP %?10000000, MSTS</b>	<b>Clear bit 7 of MSTS</b>						
<b>MDVP %?10001000, MCTL0</b>	(ACT/-)	/RSRT	/LODUTY	/MDIR	/NACK	/BCMI	/BCMD)
	1	0	0	1	0	0	0

When the two instructions above are executed, the I2C bus will receive one byte of data from the slave. After the interrupt or checking the INT5\_1F flag, the valid one byte of data can be taken by reading MDR.

<b>MDVP MDATA, A</b>	<b>Stores read data into the A register</b>
<b>MDVP %?10000000, MSTS</b>	<b>Clear bit 7 (INT5_1F) of MSTS</b>

g) Last one byte read

<b>MDVP %?10001100, MCTL0</b>	(ACT/-)	/RSRT	/LODUTY	/MDIR	/NACK	/BCMI	/BCMD)
	1	0	0	1	1	0	0

After reading this byte, the I2C bus master should generate a stop condition. To do this, it must send the message "this is the last byte" by not generating the ACK (knowledge) signal. This module does not generate the ACK signal by setting bit 2 (NACK) of MCTL0 to 1. After the interrupt or checking the INT5\_1F flag, the last one byte of data can be taken by reading MDATA.

<b>MDVP MDATA, B</b>	<b>Stores read data into the B register</b>
<b>MDVP %?10000000, MSTS</b>	<b>Clear bit 7 (INT5_1F) of MSTS</b>

h) Terminate transfer action (stop condition generation)

<b>MDVP %?10000001, MCTL0</b>	(ACT/-)	/RSRT	/LODUTY	/MDIR	/NACK	/BCMI	/BCMD)
	1	0	0	0	0	0	1

After generating the stop condition, the INT5\_1F will be set. If needed, the interrupt can be masked or this bit may not be checked. However, to begin another transfer on the I2C bus, this bit should be cleared first.



### 5.7.2 Slave Mode

The DMC73C167 can be used as an I2C slave receiver and/or transmitter. The slave address is not set by hardware but is programmable by software. There are three peripheral registers for I2C slave operations: SCTL, SADDR, and SDATA.

#### 5.7.2.1 Slave Control Registers

Table 5-35. P56 0138h SCTL I2C Slave Control

Bit	7	6	5	4	3	2	1	0
R	ENABLE	Not Used			SEL	SDIR	GCALL	INT5_2F
W	Not Used							INT5_2C

- Bit 7** ENABLE. Enables I2C Slave Hardware (R/W).  
Upon a hardware reset, this bit will be zero. After initialization of SADDR, this bit can be set to enable the slave module. ENABLE is to be read from and written to by software.
- Bit 3** SEL. Device Selected (READ).  
The general call address or address match will set this bit.
- Bit 2** SDIR. Slave Data Direction (READ).  
0 = Slave receiver (data read from I2C bus)  
1 = Slave transmitter (data written to I2C bus)
- Bit 1** GCALL. General Call.  
0 = Normal  
1 = Detects general call address.
- Bit 0** INT5\_2F. I2C Slave Interrupt Flag (READ).  
This flag is identical to bit 5 of IOCTL4. The following cases will set INT5\_2F and generate an interrupt if enabled.  
1) Slave transmitter mode (SDIR=1): Just after the slave address is selected (SEL=1)  
2) Slave receiver mode (SDIR=0): The slave address is selected after receiving one byte.  
3) After each byte of data is received or transmitted. But the interrupt will not be generated after the last byte is transmitted because there will be no acknowledge signal from the master.  
INT5\_2C. Clear I2C Slave Interrupt Flag (WRITE).  
0 = No effected.  
1 = Clears INT5\_2 flag.

**Notes:**

- 1) Before clearing the INT5\_2F bit, data must be read from or written to the SDATA register.
- 2) The SCL will be pulled down when INT5\_2F is set to high. But when it is cleared, the SCL line will be released and can be controlled by the master device.



Table 5-36. P54 0136h SADDR I2C Slave Address

Bit	7	6	5	4	3	2	1	0
R	-	Not Used						
W	-	7-bit Slave Address						

**Bit 7** Not used.

**Bit 6-0** 7-bit Slave Address Register (READ/WRITE).

The Slave address register is programmable. This register must be set with the appropriate value before the slave hardware logic is enabled, that is before setting the ENABLE bit of SCTL.

Table 5-37. P55 0137h SDATA I2C Slave Data

Bit	7	6	5	4	3	2	1	0
R	Slave Receive Data							
W	Slave Transmit Data							

**Bit 7-0** Slave Receive/Transmit Data (READ/WRITE).

The CPU can read or write parallel 8-bit data. During data transfer from/to the I2C, data is shifted bit by bit. The receiving data will be read when INT5\_2F=1, after which the INT5\_2F flag should be cleared. The transmitting data will be written when INT5\_2F=1, after which the INT5\_2F flag should be cleared.

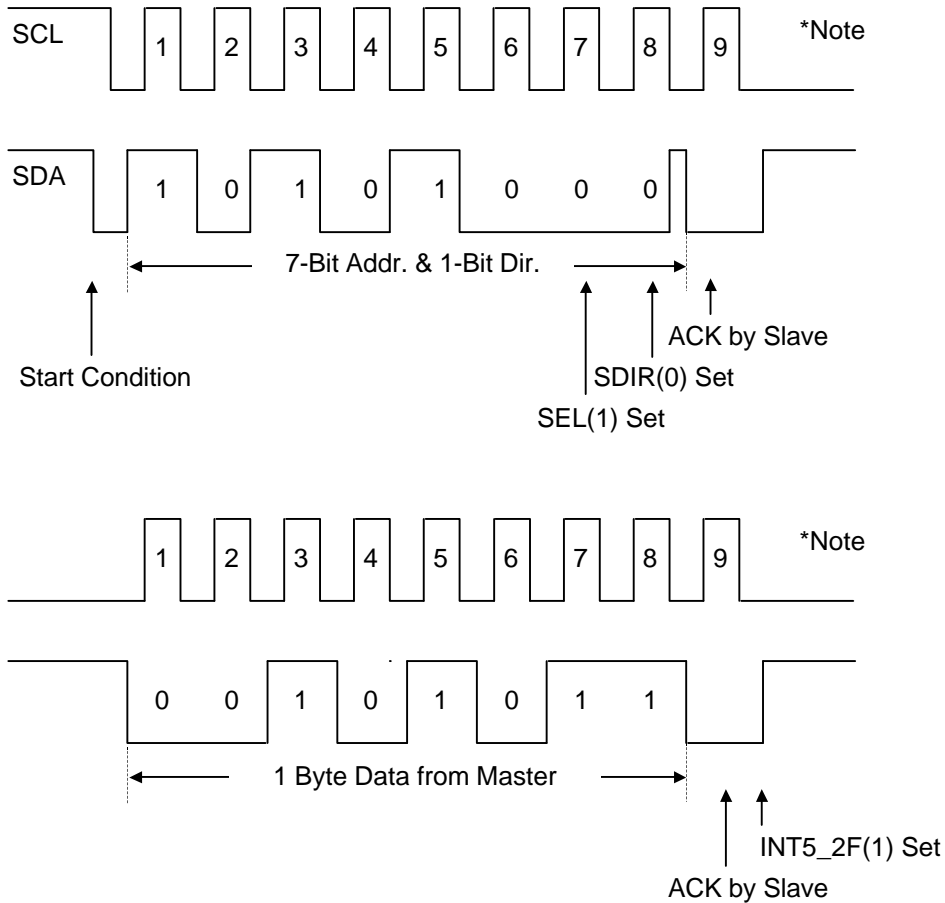
## 5.7.2.2 Timing of Slave Mode Operations

### 5.7.2.2.1 Slave Receiver Mode

If the slave receives its slave address from the master, the contents of the P56 register will be set to SEL=1/SDIR=0/GCALL=0/INT5\_2F=0. If one byte of data is received, the INT5\_2F flag will be set, and the interrupt will occur. At that time the contents of the P56 register will be set to SEL=1/SDIR=0/GCALL=0/INT5\_2F=1. After that, the INT5\_2F flag will be set every time one byte of data is received.

This waveform shows the address cycle and the transfer of one byte of data during the master transmitter mode (slave receiver mode). At the seventh SCL high, if the slave address matches, the SEL bit will be set. At the eighth SCL high, the SDIR bit will be set to zero, and after the eighth SCL falling, the slave will generate ACK on the SDA line. On receipt of each byte of data from the master, the slave interrupt (INT5\_2F) is generated.

Figure 5-12. Data Transfer in Slave Receiver Mode



\*Note : At this point INT5\_1F is set when used as the master device.

#### 5.7.2.2.2 Slave Transmitter Mode

If the slave receives its slave address from the master, the contents of the P56 register will be set to SEL=1/SDIR=1/GCALL=0/INT5\_2F=1. If the slave sends one byte of data, one byte of data should be written to SDATA (P55) before the INT5\_2F flag is cleared. If the master returns ACK every time one byte of data is received from the slave, the interrupt of the slave will occur. But if the master returns NACK to the slave, the interrupt of the slave will not occur.

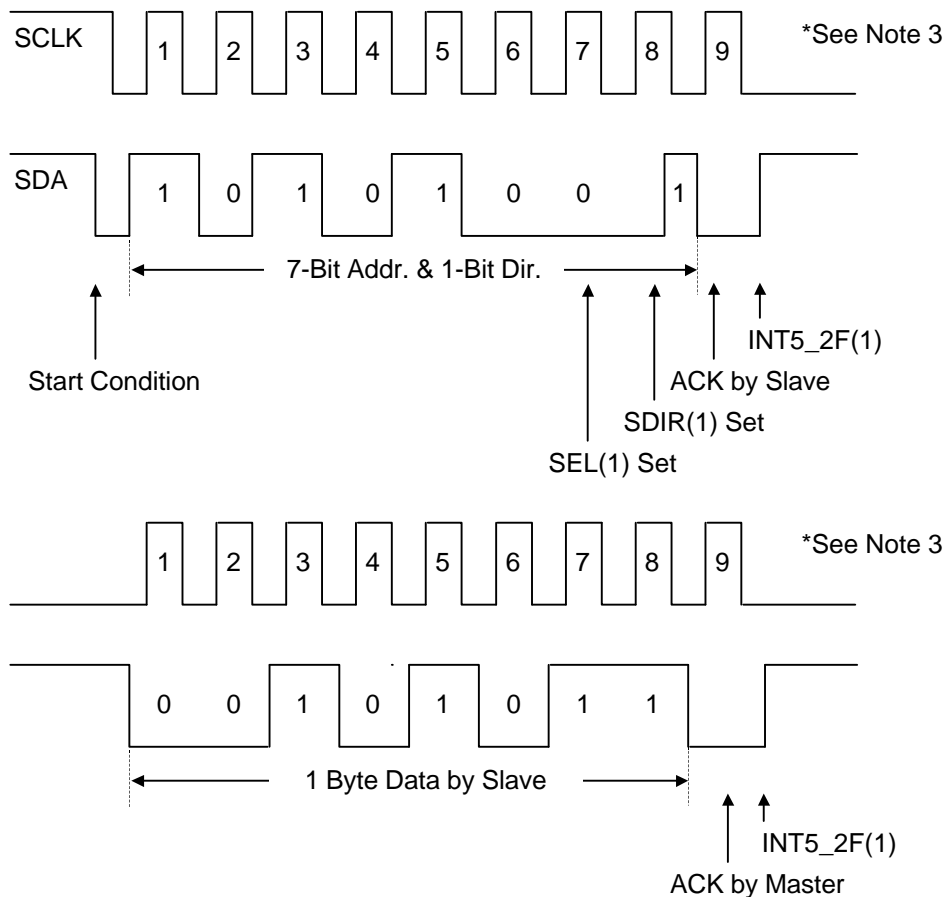
The accompanying waveform shows the address cycle and the transfer of one byte of data during the master receiver mode (slave transmitter mode). At the seventh SCL

high, the SDIR bit will be set to 1, and after the eighth SCL falling, the slave will generate ACK on the SDA line. After every address and data cycle, INT5\_2F is set, and the INT5\_2 interrupt is generated when it is enabled.

**Notes:**

- 1) If ACK is not generated by the master (NACK) when one byte of data is transferred, the slave interrupt will not occur. At that point the master should initiate a stop cycle or a restart cycle.
- 2) The slave flags (SEL/SDIR/GCALL) except INT5\_2F will be cleared after the slave receives the stop condition or restart condition.
- 3) INT5\_1F is set when this device is used as the master.

Figure 5-13. Data Transfer in Slave Transmitter Mode



### 5.7.2.3 Slave Mode Operations

First the slave address must be set by writing the address value to SADDR. Then bit 7 (SMON) of SCTL must be set to turn on the slave module. When the slave module is selected (via an address match or general call address), an interrupt will occur. When this happens, the status bit (SDIR and GCALL) must be checked. If the master wants to receive data from the slave module (SDIR=1), SDATA should be written with the proper data, and then INT5\_2F must be cleared.

The following instructions are an example of slave mode operations.

MOV	%21h,	SADDR		Slave address = 21h
MOV	10000001,	SCTL		(ENABLE/-----/INT5_2C)
				1 1
LOOP	BTJZP %01h,	SCTL,	LOOP	Waits for INT5_2F = 1
	BTJOP %02h,	SCTL,	ADD0	If GCALL = 1 does special operation
	BTJOP %04h,	SCTL,	SEND	If SDIR = 1 sends data to master
	MOV	SDATA,	A	If SDIR = 0 receives data from master
	MOV	10000001,	SCTL	Clears INT5_2F flag
	:			(ENABLE/-----/INT5_2C)
	:			1 1
	:			
SEND	MOV	%AAh,	SDATA	If SDIR = 1 sends data AAh to master
	MOV	10000001,	SCTL	Clears INT5_2F flag
	:			(ENABLE/-----/INT5_2C)
	:			1 1
	:			
ADD0	MOV	SDATA,	B	If GCALL = 1 reads data from master
	MOV	10000001,	SCTL	Clears INT5_2F flag
	:			(ENABLE/-----/INT5_2C)
	:			1 1
	:			
				Decodes contents of the B register



## 5.8 6-bit PWM (PWM1\_0-PWM1\_8)

### 5.8.1 Description of PWM1

The DMC73C167 microcontrollers feature nine PWM output ports.

Each port contains 6-bit resolution.

The ports are provided for the application of analog circuit control when combined with an external low pass filter circuit. As shown in Figure 5-14, the 6-bit PWM is composed of a 6-bit timer, two 6-bit latches, and two 6-bit comparators. When started the 6-bit timer is filled up with 3Fh and increments during every period of  $F_{osc}/16$ . The 6-bit timer is used for all 6-bit PWMs in common. For any of the nine PWMs to start, the 6-bit timer must already be started. If the value of the 6-bit timer is greater than a value of the latched 6-bit data, the comparator output is logic high status.

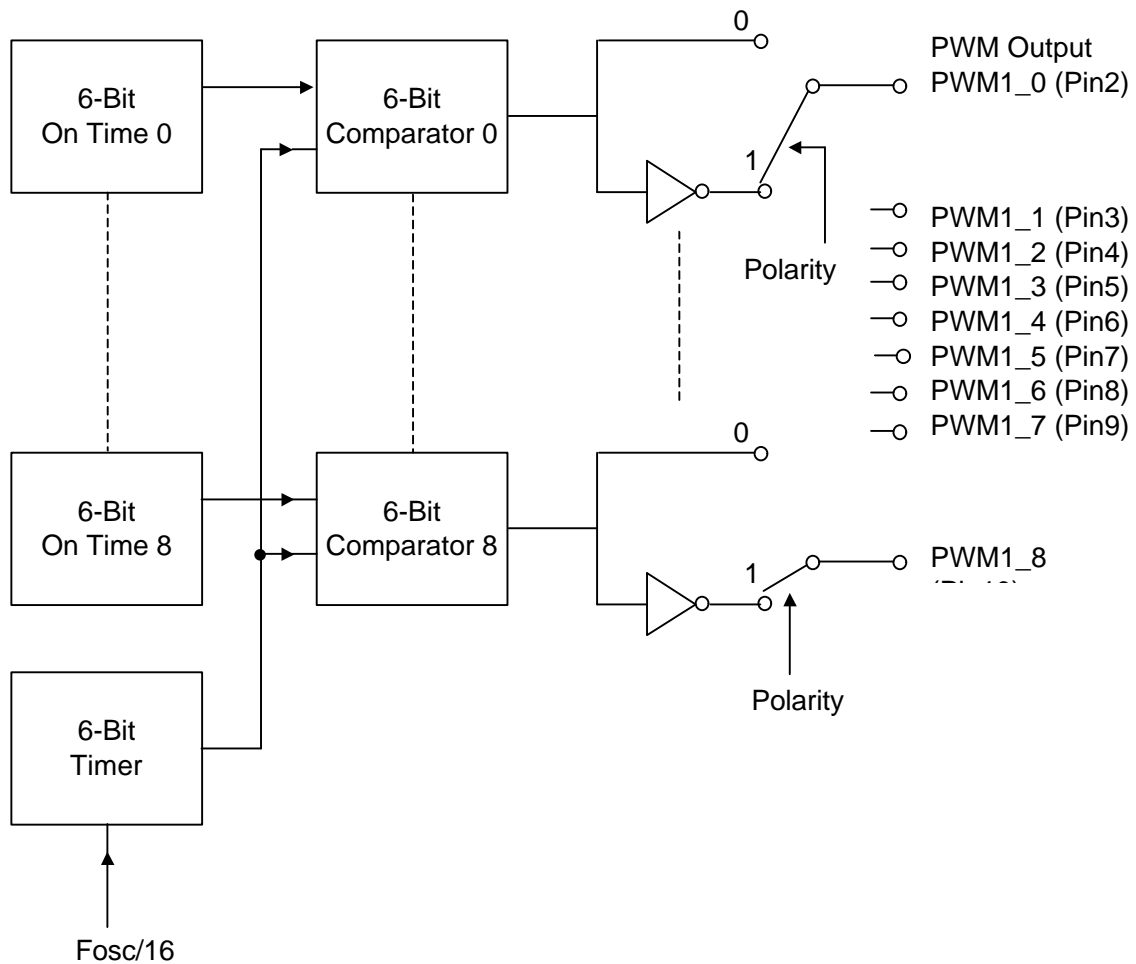
Each PWM output port contains its own polarity control bit, which enables the port to be selected as inverted or non-inverted output. If the PWM function is not required, the port to be selected as inverted or non-inverted output. If the PWM function is not required, the port could easily be used as a normal digital output port through polarity control.

#### Notes:

PWM1\_0-PWM1\_8 ports are +12 V open-drain output.



Figure 5-14. 6-bit PWM Block Diagram



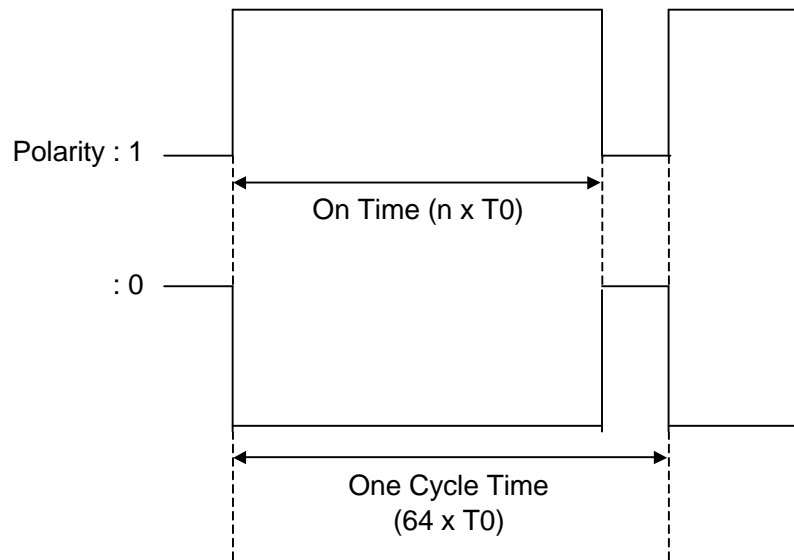
The pulse width can be modulated by the minimum pulse with  $T_0$  depending on the latched 6-bit data. The 6-bit data determines the duty of the PWM signal.

On-time =  $n$  (value of 6-bit data)  $\times T_0$

One Cycle Time =  $64 \times T_0$  (256 $\mu$ s at  $F_{osc} = 4$ MHz)

where:  $T_0 = 16/F_{osc}$  ( $T_0 = 4\mu$ s at  $F_{osc} = 4$ MHz)



*Figure 5-15. 6-bit PWM Output Waveform*

## 5.8.2 6-bit PWM Control Registers

Table 5-38. P37 0125h PWM1CTL 6-bit PWM Control

Bit	7	6	5	4	3	2	1	0
RW	START	0	0	0	0	0	0	0

**Bit 7** START. 6-bit PWM START (R/W).

0 = Stops 6-bit PWM counter.

1 = Starts 6-bit PWM counter.

**Bit 6-0** Should be zero.

Table 5-39. P38 0126h PWM1\_0T 6-bit PWM1\_0 Time

Bit	7	6	5	4	3	2	1	0
R	—	PWM1_0	Not Used					
W	—	POLE	PWM1_0 OCR Value					

Table 5-40. P39 0127h PWM1\_1T 6-bit PWM1\_1 Time

Bit	7	6	5	4	3	2	1	0
R	—	PWM1_1	Not Used					
W	—	POLE	PWM1_1 OCR Value					

Table 5-41. P40 0128h PWM1\_2T 6-bit PWM1\_2 Time

Bit	7	6	5	4	3	2	1	0
R	—	PWM1_2	Not Used					
W	—	POLE	PWM1_2 OCR Value					

Table 5-42. P41 0129h PWM1\_3T 6-bit PWM1\_3 Time

Bit	7	6	5	4	3	2	1	0
R	—	PWM1_3	Not Used					
W	—	POLE	PWM1_3 OCR Value					

Table 5-43. P42 012Ah PWM1\_4T 6-bit PWM1\_4 Time

Bit	7	6	5	4	3	2	1	0
R	—	PWM1_4	Not Used					
W	—	POLE	PWM1_4 OCR Value					



Table 5-44. P43 012Bh PWM1\_5T 6-bit PWM1\_5 Time

Bit	7	6	5	4	3	2	1	0
R	—	PWM1_5	Not Used					
W		POLE	PWM1_5 OCR Value					

Table 5-45. P44 012Ch PWM1\_6T 6-bit PWM1\_6 Time

Bit	7	6	5	4	3	2	1	0
R	—	PWM1_6	Not Used					
W		POLE	PWM1_6 OCR Value					

Table 5-46. P45 012Dh PWM1\_7T 6-bit PWM1\_7 Time

Bit	7	6	5	4	3	2	1	0
R	—	PWM1_7	Not Used					
W		POLE	PWM1_7 OCR Value					

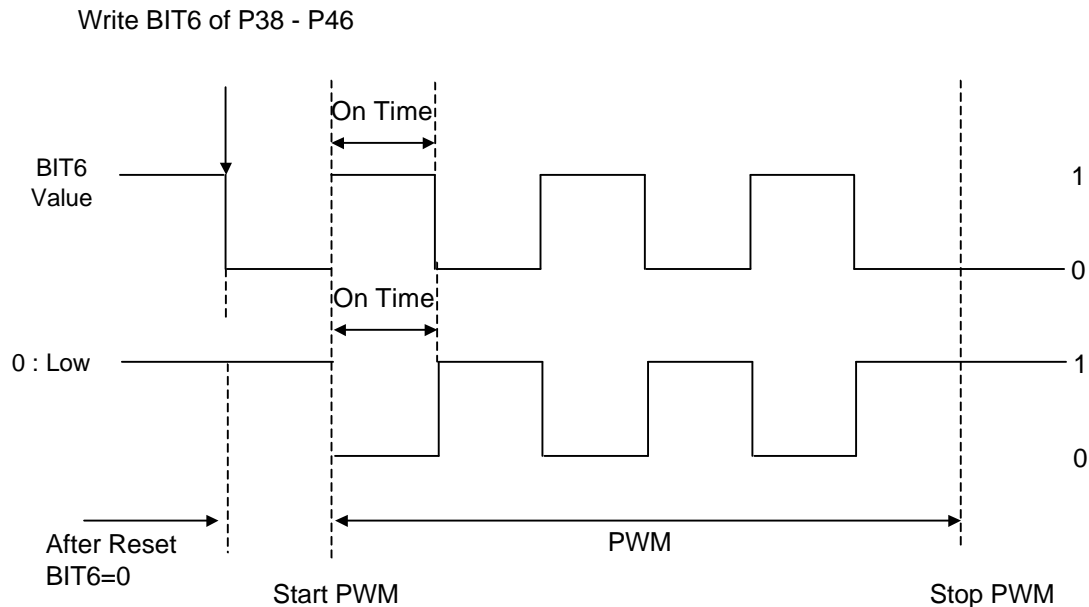
Table 5-47. P46 012Eh PWM1\_8T 6-bit PWM1\_8 Time

Bit	7	6	5	4	3	2	1	0
R	—	PWM1_8	Not Used					
W		POLE	PWM1_8 OCR Value					

- Bit 0-5** PWM1\_n OCR. Output Compare Register.  
This is a write-only register that defines the high or low output pulse width.
- Bit 6** PWM1\_n POLE. Polarity of PWM Output.  
0 = Active low (port output is high when the OCR value is 0.)  
1 = Active high (port output is low when the OCR value is 0.)  
When PWM is stopped at each timing, the PWM output depends on the polarity value (the value of bit 6).
- Bit 7** Not used.



Figure 5-16. Timing and Polarity of 6-bit PWM1\_0-PWM1\_8 Output



## 5.9 14-bit PWM (PWM0)

### 5.9.1 Description of PWM0

The periodic interval  $T = 5.4\text{ms}$  ( $F_{OSC} = 6\text{MHz}$ ) can be divided into 16k minimum pulse width  $T_0 = 333\text{ns}$  ( $F_{OSC} = 6\text{MHz}$ ), and the pulse width can be modulated by the T0 unit depending on the 14-bit data. Also, by generating a small periodic interval  $T_s = 85\mu\text{s}$  ( $F_{OSC} = 6\text{MHz}$ ), which is  $256 \times T_0$ , pulses of almost equal width can be output with a period of  $T_s$ .  $T_m$  ( $m = 1 - 64$ ), defined as the signal duration in 64 small intervals, is calculated as follows. First, the 14-bit data is split into two parts: the most significant 6 bits and the least significant 8 bits. The value of the LS 8 bits determines the interval of basic time. Hence,  $T_m$  ( $1 - 64$ ) = (number indicated by 8 bits)  $\times T_0$  in the 64 small intervals. Furthermore, the 6-bit data decides how many  $T_0$ s are added one by one in the 64 intervals. The relationship between the 6-bit data and  $T_m$  is illustrated in Figure 5-24, and the basic 14-bit PWM waveform is shown in Figure 5-25.



Figure 5-17. 14-bit PWM Block Diagram

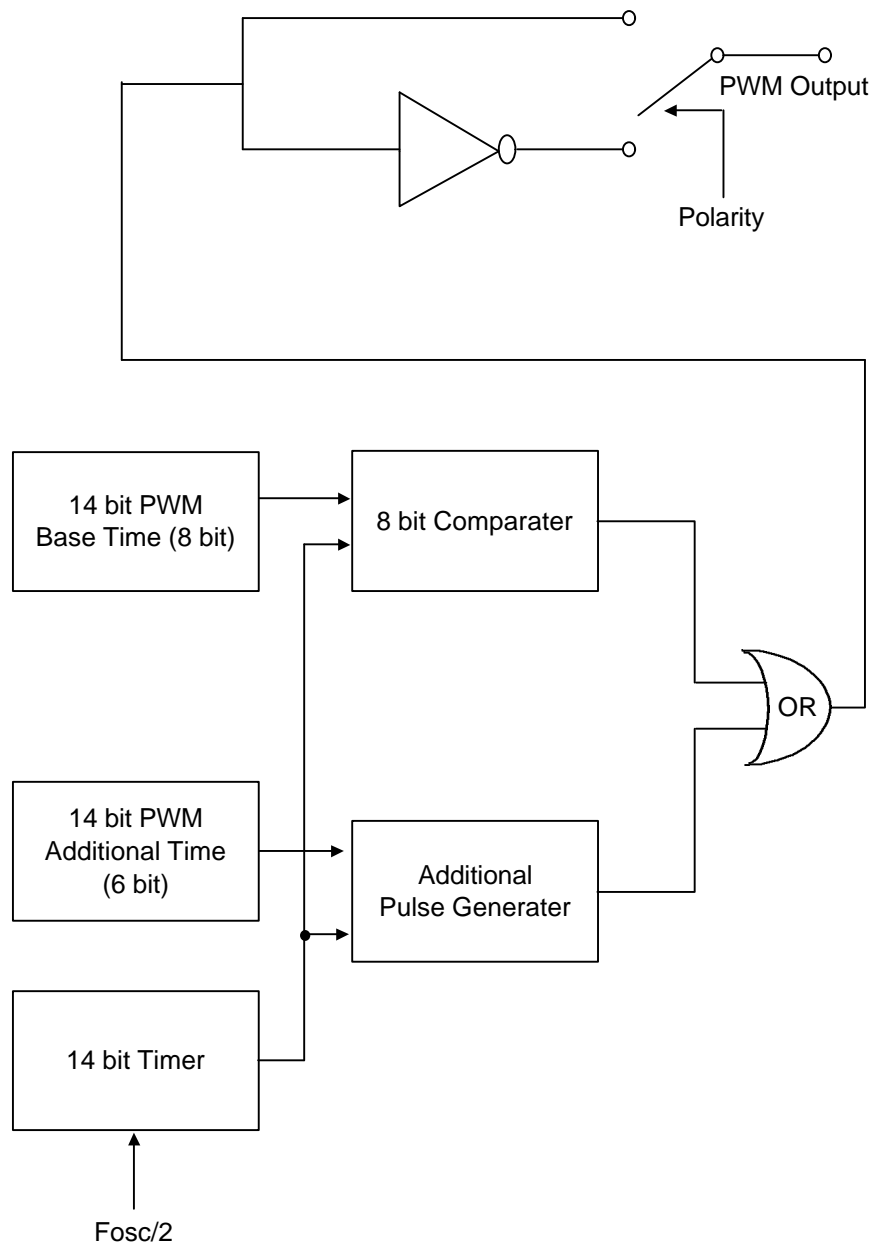
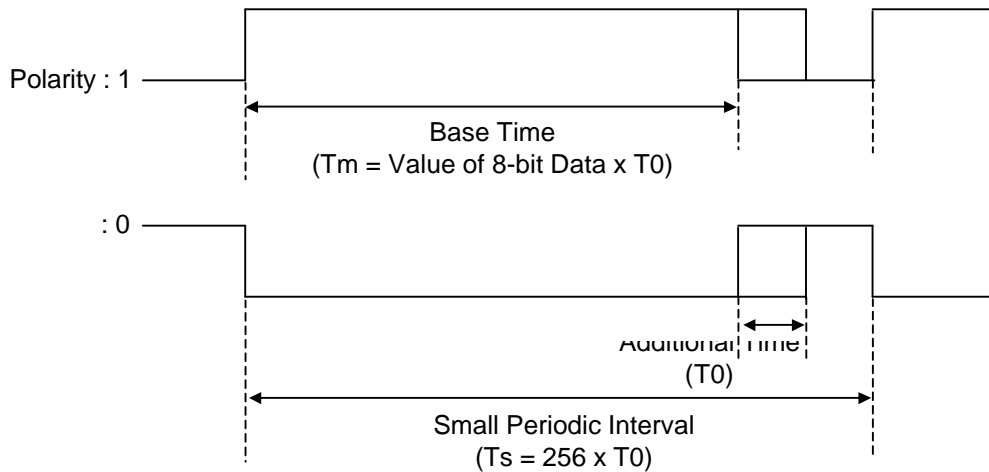


Figure 5-18. 14-bit PWM 1 Cycle and On Time



Small periodic interval  $T_s = 256 \times T_0$  (128us:Fosc = 4MHz)

Base Time  $T_m = (\text{value of 8-bit data}) \times T_0$

Additional time =  $T_0$

Where:  $T_0 = 2/\text{Fosc}$  ( $T_0 = 500\text{ns}$  at  $\text{Fosc} = 4\text{MHz}$ )

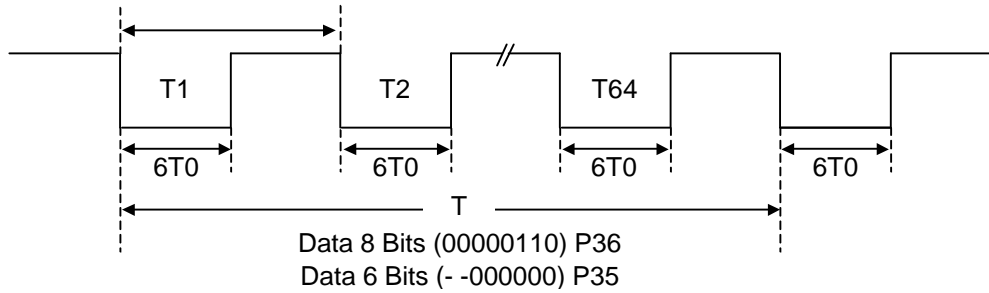
Table 5-48. 6-bit Data and  $T_m$ 

6-bit Data (P36)	Interval ( $T_0$ ) Adding Position
LSB	
0 0 0 0 0 0	None
0 0 0 0 0 1	$m = 32$
0 0 0 0 1 0	$m = 16, 48$
0 0 0 1 0 0	$m = 8, 24, 40, 56$
0 0 1 0 0 0	$m = 4, 12, 20, 28, 36, 44, 52, 60$
0 1 0 0 0 0	$m = 2, 6, 10, \dots, 54, 58, 62$
1 0 0 0 0 0	$m = 1, 3, 5, \dots, 59, 61, 63$

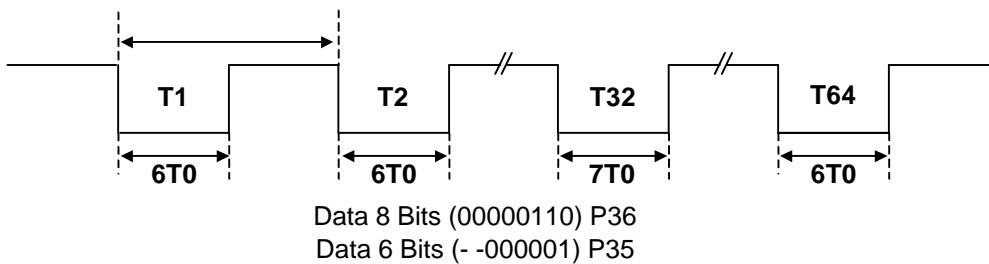


Figure 5-19. 14-bit PWM Output Waveform

$$256 \times T_0 = 128\mu\text{s}$$



$$256 \times T_0 = 128\mu\text{s}$$



### 5.9.2 PWM0 Control Registers

Table 5-49. P32 0120h PWM0CTL 14-bit PWM Control

Bit	7	6	5	4	3	2	1	0
RW	START	TEST	Not Used		POLE	Not Used		

**Bits 0-2** Not Used

**Bit 3** PWM0 POLE. PWM0 Polarity Control.

0 = Active low.

1 = Active high.

**Bits 4, 5** Not Used

**Bit 6** PWM0 TEST. For Test Mode Only.

Should always be 0.

**Bit 7** PWM0 START.

0 = Stop PWM0.

1 = Run PWM0.



Figure 5-20.

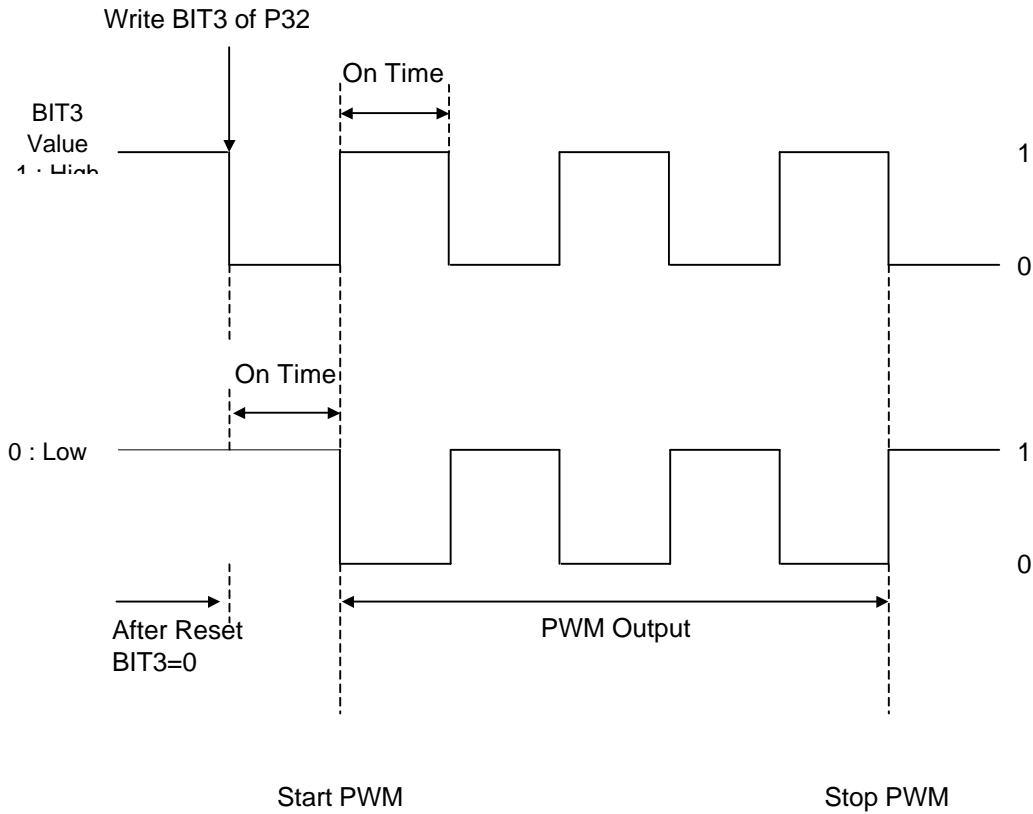


Table 5-50. P35 0123h PWM0AT 14-bit PWM Add Time

Bit	7	6	5	4	3	2	1	0
R	Not Used		Not Used					
W	Not Used		14-bit PWM OCR Additional Value					

Table 5-51. P36 0124h PWM0BT 14-bit PWM Base Time

Bit	7	6	5	4	3	2	1	0
R	Not Used							
W	14-bit PWM OCR Base Value							

**Note:**

Smoothly any additional bit divides equally by 32 cycles when the bit is integrated.





### 5.10 On Screen Display

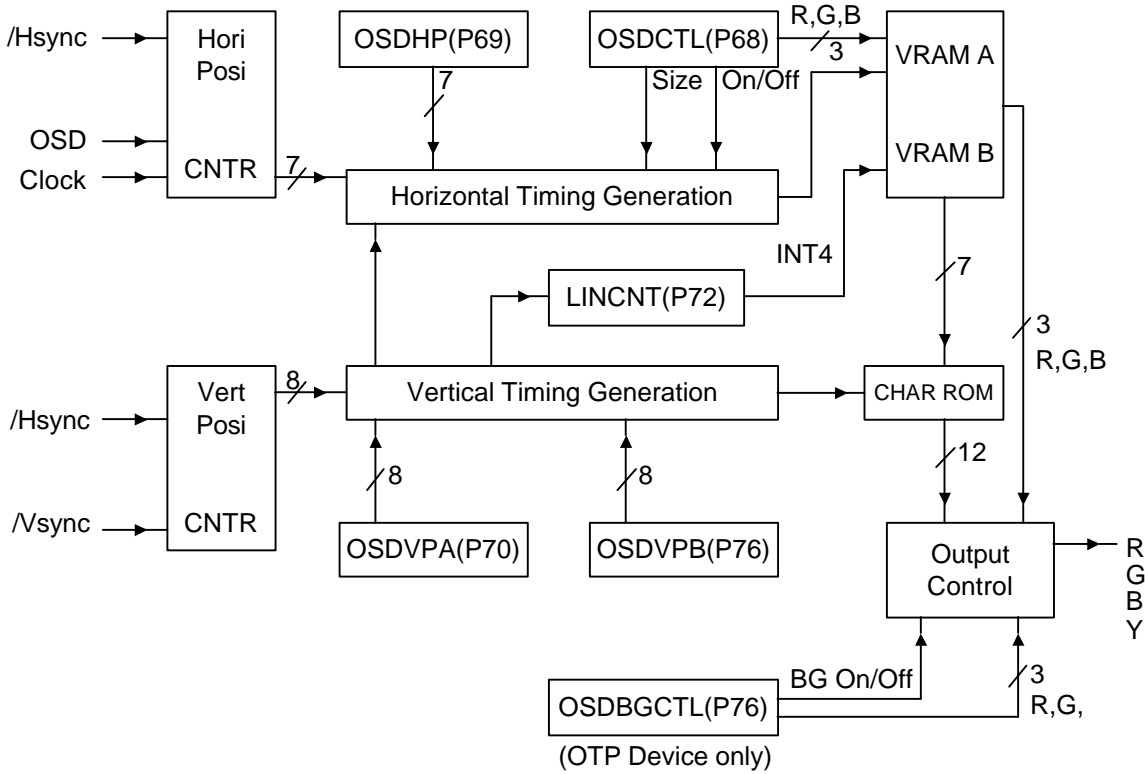
The DMC73C167 on screen display (OSD) hardware has two separate video RAM blocks called Line A and Line B. Both Line A and Line B can be accessed by the CPU separately. Thus, it is possible to modify video RAM data while one line is being accessed by the video display controller. So multiple lines are easily displayed with the help of the display line counter which is supported by on-chip hardware.

#### 5.10.1. Major Features of the OSD Module

Number of display patterns	2 independent lines x 20 columns (max of 12 lines by software control)
Number of character fonts	128
Character font structure	12 x 18
Character color	8 colors for each character
Character size	x1 (20 columns), x4 (10 columns)
Horizontal position	2 dots/1 bit, 7 bits (max 256 dots move)
Vertical position	2H/1 bit, 8 bit
OSD interrupt counters	4bits, cleared by VSYNC
OSD interrupt sources	INT4



Figure 5-21. OSD Functional block



5.10.2 OSD Control Registers

Table 5-52. P68 0144h OSDCTL OSD Control Register

Bit	7	6	5	4	3	2	1	0
RW	START	Not Used			SIZE	R	G	B
						CHARACTER COLOR		

- Bit 7** START. OSD On/Off. (R/W)  
0 = Stop.  
1 = Start, Restart.
- Bit 3** SIZE. Select Size. (R/W)  
0 = Normal (1 x 1)  
1 = Double (2 x 2)



**Bits 2-0** Character Color. (R/W)

000 = Black

001 = Blue

010 = Green

011 = Cyan

100 = Red

101 = Magenta

110 = Yellow

111 = White

Table 5-53. P72 0148h LINCNT Current Display Line Designator

Bit	7	6	5	4	3	2	1	0
R	Not Used				Display Line Counter Value			
W					(User Write Not Allowed)			

**Note:**

This is cleared at the falling edge of VSYNC or a hardware reset. It is incremented by one after displaying one line, which occurs simultaneously with the OSD interrupt.

Table 5-54. P69 0145h OSDHP OSD Horizontal Position

Bit	7	6	5	4	3	2	1	0
RW	Not Used	Horizontal (X) Position						

Horizontal (X) = Adjust position right or left 01h-7Fh  
(2 dots/1 bit)

Table 5-55. P70 0146h OSDVPA OSD Vertical Position for Video RAM A

Bit	7	6	5	4	3	2	1	0
RW	Vertical Position Data for Line A							

Adjust position upper or lower 000h-FFh  
(2H/1 bit)



Table 5-56. P71 0147h OSDVPB OSD Vertical Position for Video RAM B

Bit	7	6	5	4	3	2	1	0
RW	Vertical Position Data for Line B							

Adjust position upper or lower 00 h-FFh

(2H/1 bit)

Character Font: 128 type. The Character color is set with the character code data which consists of a total of 10 bits: 7 bits (character font) + 3 bits (character color) for each character.

<Video RAM File> Note: (1)

Address Range	Contents
0160h-0173h	OSD A Line Character Address
0180h-0193h	OSD B Line Character Address

Table 5-57. P67 0143h PRTCL OSD YOUT Polarity Control

Bit	7	6	5	4	3	2	1	0
RW	POLRCTL	Not Used						

**Bit 7** POLRCTL OSD YOUT Polarity.  
 0 = High active.  
 1 = Low active



### 5.10.3 OSD Interrupt and Operation

Before starting the display, the user should write the first line of display information to video RAM A and OSDVPA, and write the second line of display data to video RAM B and OSDVPB. Then set the START bit (bit 7 of OSDCTL) to turn on the OSD module.

The OSD interrupt will occur when the condition causing the interrupt sets the interrupt flag (bit 1 of IOCTL1) to 1 and when the interrupt enable bit (bit 0 of IOCTL1) is set to 1 regardless of the OSD START bit (P68, bit 7). The interrupt flag will be set if one of the following cases occurs:

- Vsync falling
- End point of each line of the display is reached

If the TV scan line comes to the value of OSDVPA, the first line A (video RAM A) will be displayed. At the end point of the line A display (the last dot of the dots making up the 20th character of line A), an interrupt will occur, and LINCNT will be incremented by one. Thus, the user can read the value "01h" from LINCNT (which designates the end of the first line of display).

From that point, the second line (line B) will start to display according to OSDVPB (V-position counter B) value. At the same time, the user can change video RAM A and OSDVPA (V-position counter A) with the data to be displayed on the third line. After the second line is displayed, another OSD interrupt will occur, and the user can read value "02h" from LINCNT. Then the display of the third line (the contents of video RAM A) will commence with the new data input from the first interrupt routine. As before, during this interrupt routine the user should write the proper data for video RAM B and OSDVPB with the data to be displayed on the fourth line of the display. A maximum of 12 lines can be displayed on the screen using this control method. Regardless of the last video RAM used (A or B), after Vsync the first line of display data will come from video RAM A and OSDVPA.

To display only one line, write "FFh" to OSDVPB. As before, when the first line is displayed the OSD interrupt will occur, and the LINCNT counter will have the value "01h". No action is needed for that interrupt if you don't want to change the display data.

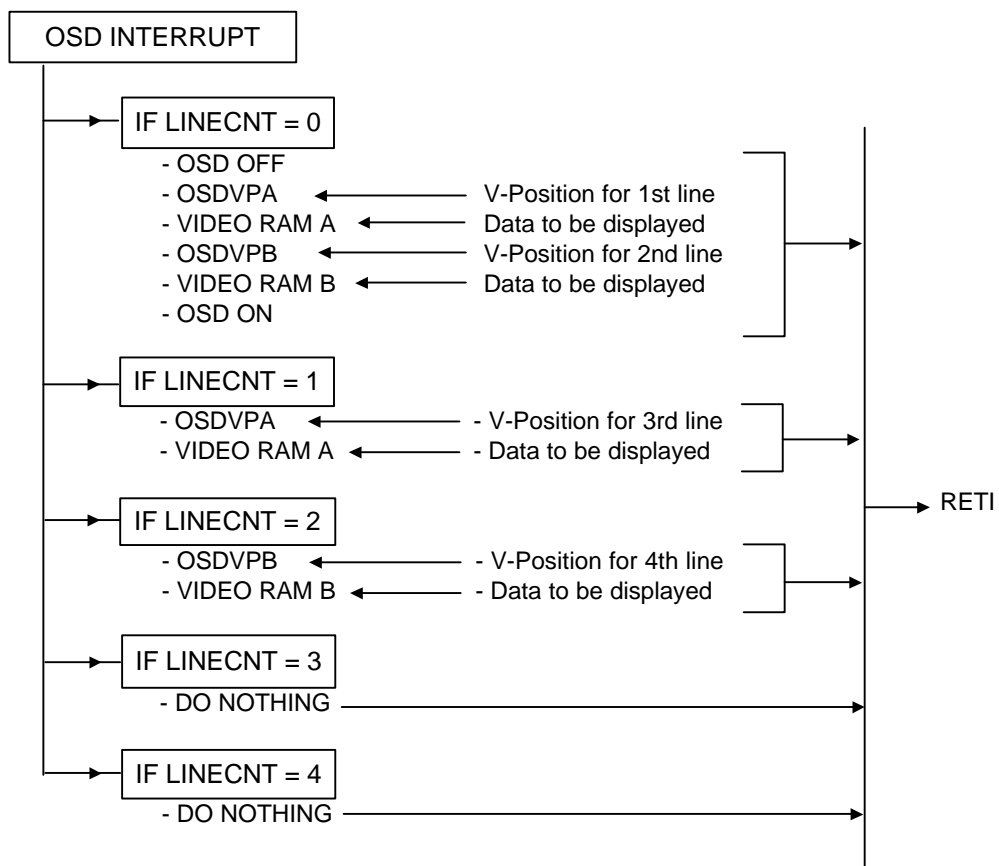


## 5.10.4 OSD Programming Example

### 5.10.4.1 Multiple-Line Display

The following flow chart is an example of a four-line display. Regardless of whether the display is an odd or even number of lines, the first line of data for any field to be displayed on the screen will come from video RAM A and OSDVPA.

Figure 5-22. Example Flow Chart of 4 Line Display



5.10.4.2 One-Line Display

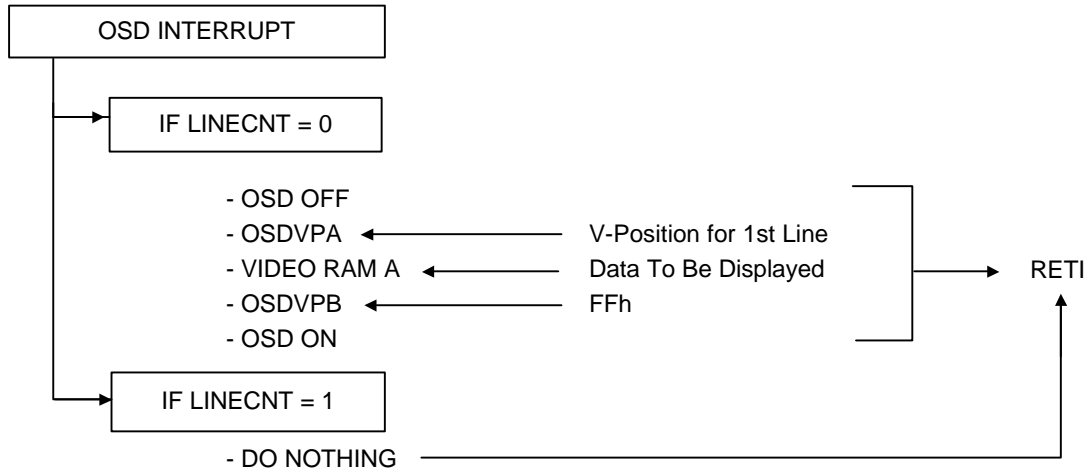


Figure 5-23. Video RAM and CPU Interface

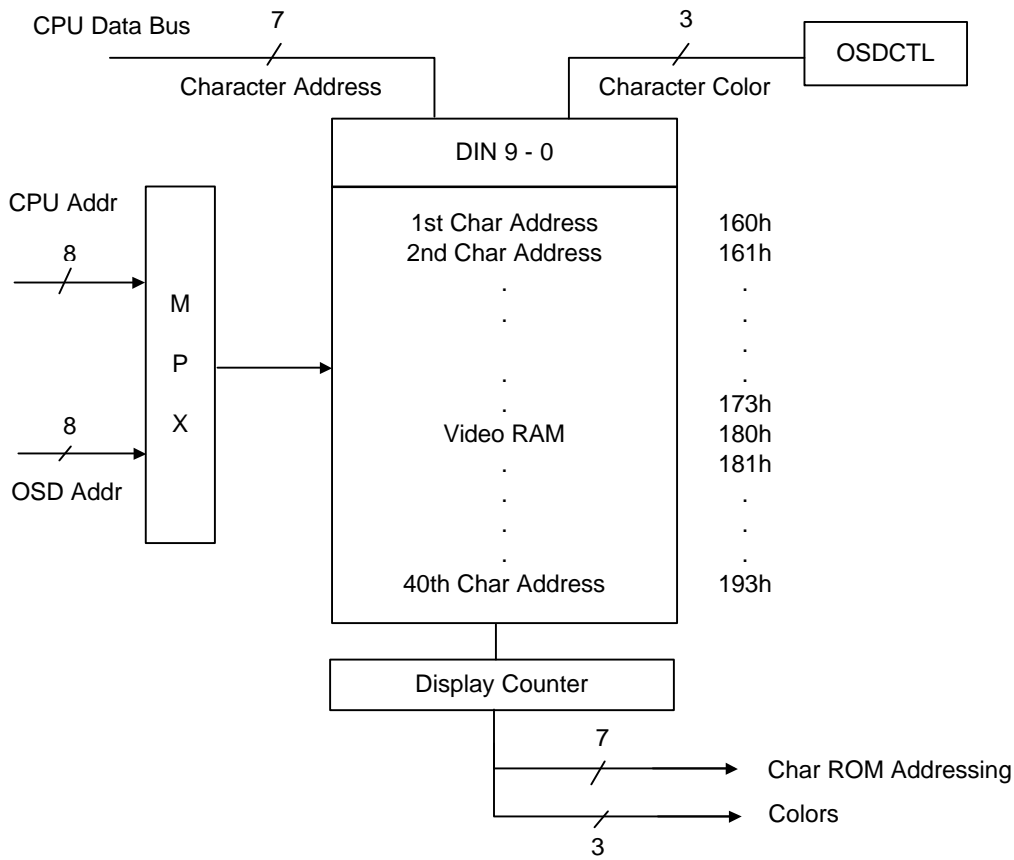
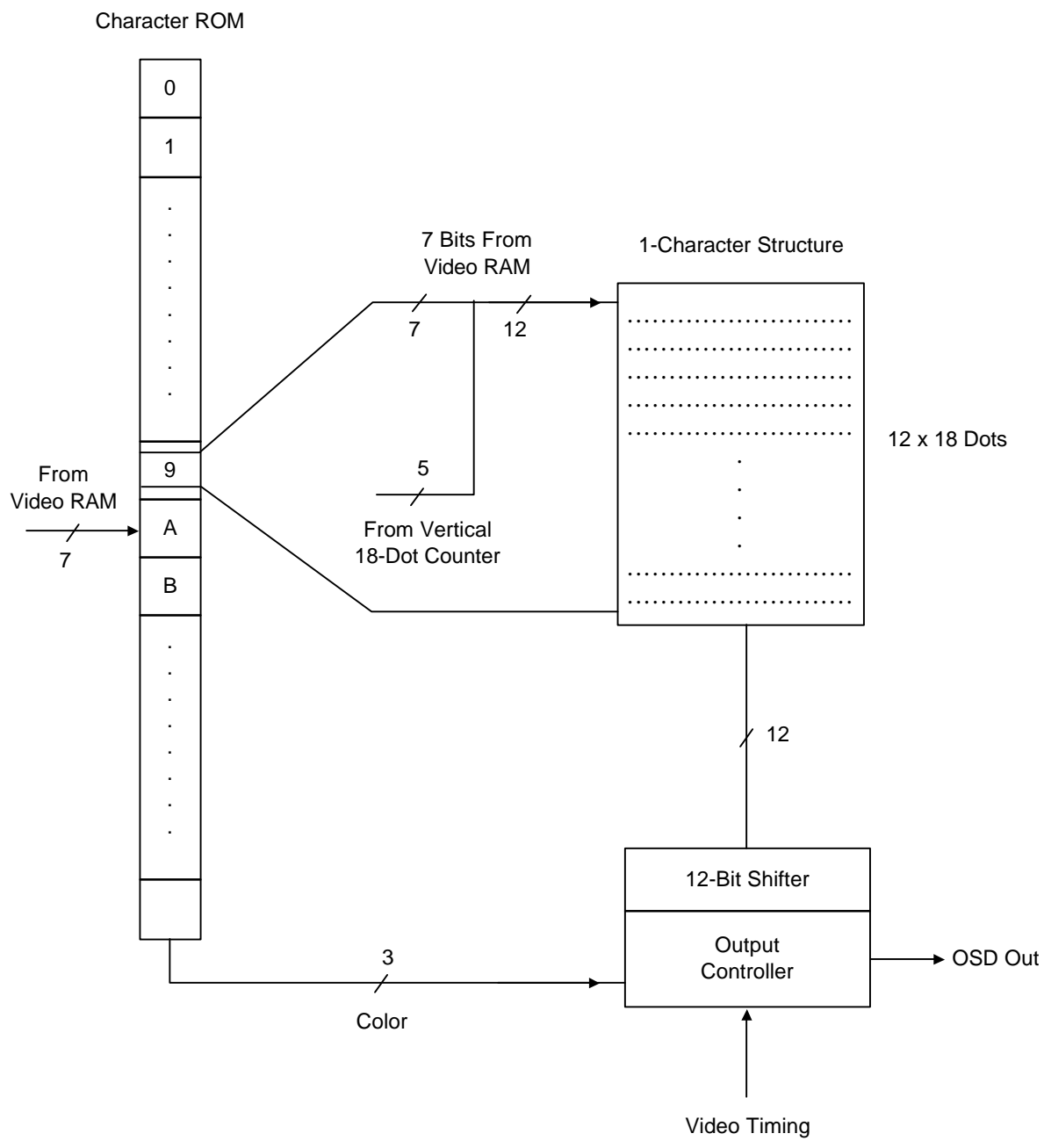


Figure 5-24. Character ROM and Character Assignment

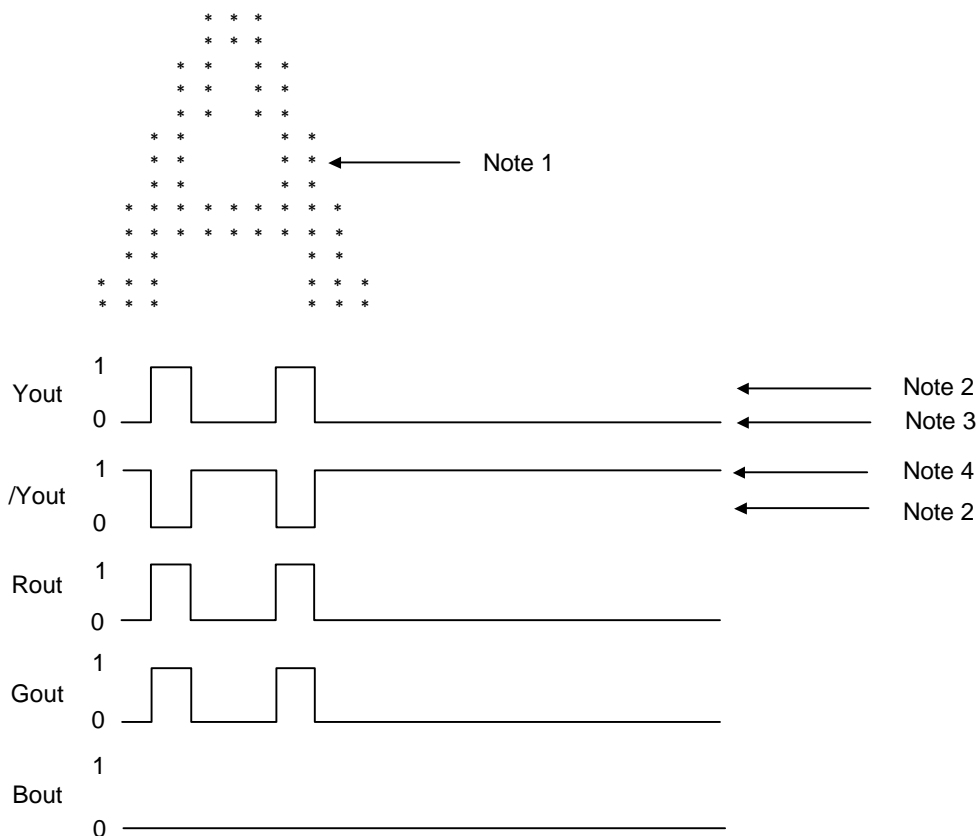




### 5.10.5 R, G, B, and Y Output Timing

R, G, B, and Y output timing are shown in the figures below.

Figure 5-25. R, G, B, and Y Output Timing



**Notes:**

- 1) R, G, B, and Y waveforms correspond to this line.
- 2) Even R, G, B, is low (color data is 0), Yout is activated when character font data is at the display location (black color).
- 3) Yout and /Yout are mask option, which mean the option is placed on a manufacturing template, or mask, that copies the actual circuit onto the silicon device. This means the Yout option is finalized at the start of manufacture and cannot be changed by either software or hardware. The Yout of (OTP) can be changed by software controls.
- 4) SE73CP87 supports the Yout signal only (active high only).



### 5.11 Low-Power Mode

The DMC73C167 supports the Halt mode as the Low-power mode.

This mode is entered when the IDLE instruction is executed.

Activating RESET or acknowledging an enabled interrupt releases the device from this mode.

This low-power mode freezes the I/O ports, retaining their conditions before the IDLE instruction was executed.

Complete RAM data retention is also maintained through this low-power mode as power is applied.

Table 5-11 describes the low-power mode.

Table 5-59. Low-Power Mode

MODE	OSC	TIMER1	TIMER2	TIMER3	EXIT MODE VIA
HALT	HALTED	HALTED	HALTED	HALTED	RESET, INT1, INT3_0, INT5_0

In this low-power mode, the A/D converter is stopped and the oscillator is halted.

**Note** : If you want to enter into Halt Mode, you must stop Timer1, Timer2 and Timer3 before executing IDLE instruction.



## 6. OTP DEVICE SPECIFICATIONS

### 6.1 Pin Assignment of OTP Programming Adapter Board

The 73CE167 can be programmed like any TMS27C128 on a wide variety of EPROM programmers. Programming the 73CE167 requires a 54-to-28 pin adapter socket with the XRESET and OSCIN pins grounded.

The following diagram shows the connections that need to be made on the 54-to-28 pin socket.

Figure 6-1. Required Connections on 54-to-28 Pin Adapter Socket

SOCKET PIN	T27C128 FUNC.	73CE167 PIN CONFIGURATION		T27C128 FUNC.	SOCKET PIN			
20	XE	PWM0 (14bit) ←	1	54 ←	VCC	VCC	28	
		PWM1_0 (6bit) ←	2	53 ↔	A7/POWER CTL	A6	4	
		PWM1_1 (6bit) ←	3	52 ↔	SCL	XG	22	
		PWM1_2 (6bit) ←	4	51 ↔	SDA	XPGM	27	
		PWM1_3 (6bit) ←	5	50 ↔	A6	A5	5	
		PWM1_4 (6bit) ←	6	49 ↔	A5/INT5_0	A4	6	
		PWM1_5 (6bit) ←	7	48 ↔	A4/INT3_0	A3	7	
		PWM1_6 (6bit) ←	8	47 ↔	A3/INT1	A2	8	
		PWM1_7 (6bit) ←	9	46 ↔	A1/ECI1	A0	10	
		PWM1_8 (6bit) ←	10	45 ←	/RESET	GND	14	
		B0/T1OUT(OPEN D) ←	11	<b>7</b>	44 →	OSC OUT(CPU)		
		B1/T3OUT(OPEN D) ←	12	<b>3</b>	43 ←	OSC IN(CPU)	GND	14
		B2(OEPN DRAIN) ←	13	<b>C</b>	42 ←	TEST	VPP	1
		B3(OEPN DRAIN) ←	14	<b>E</b>	41 ↔	A2/ECI2	A1	9
3	A7	B4(OEPN DRAIN) ←	15	<b>1</b>	40 →	OSC OUT(OSD)		
25	A8	B5(OEPN DRAIN) ←	16	<b>6</b>	39 ←	OSC IN(OSD)	GND	14
24	A9	B6(OEPN DRAIN) ←	17	<b>7</b>	38 ←	/Vsync	GND	14
21	A10	B7(OEPN DRAIN) ←	18		37 ←	/Hsync	GND	14
14	GND	A0/4BIT ADC ←	19		36 →	Yout or /Yout		
11	Q1	C0 ↔	20		35 →	BLUE		
12	Q2	C1 ↔	21		34 →	GREEN		
13	Q3	C2 ↔	22		33 →	RED	GND	VCC
15	Q4	C3 ↔	23		32 ↔	D3-CH/XUROM	14 OR 28 D S/W	
16	Q5	C4 ↔	24		31 ↔	D2	A13	26
17	Q6	C5 ↔	25		30 ↔	D1	A12	2
18	Q7	C6 ↔	26		29 ↔	D0	A11	23
14	GND	VSS →	27		28 ↔	C7	Q8	19



**8Bit Single Chip Microcontroller****DMC73C167**

Notes : 1) PWM1\_(0 to 8), B (0 to 3), Yout, OSCOUT (OSD/CPU), BLUE, RED, GREEN ==> Open.

2) CHROM/XUROM (#32) = Low ==> 16K user EPROM  
programming and read  
= High ==> character EPROM  
programming and read

3) For signature mode, insert a 3.9 Kohms resistor between the pin #24 of the socket and the pin #17 of the 73CE167.

4) In R bit program and verify mode, #37 and #38 ==> VCC.

Table 6-1. 73CE167 Pin Assignments

Normal Mode				EPROM Mode			TMC27C128	
Signal	Pin No.	I/O	Description	Signal	I/O	Description	Name	Pin No.
A0	19	I/O	4-bit ADC	-	-			
A1	46	I/O	ECI1	A0	I		A0	10
A2	41	I/O	ECI2	A1	I		A1	9
A3	47	I/O	INT1	A2	I	EPROM	A2	8
A4	48	I/O	INT3	A3	I	Address	A3	7
A5	49	I/O	INT5	A4	I		A4	6
A6	50	I/O		A5	I		A5	5
A7	53	I/O		A6	I		A6	4
B0	11	O	OPEN DRAIN (2 NTR) 12V	-	-			
B1	12	O	OPEN DRAIN (2 NTR) 12V	-	-			
B2	13	O	OPEN DRAIN (2 NTR) 12V	-	-			
B3	14	O	OPEN DRAIN (2 NTR) 12V	-	-	EPROM		
B4	15	O	OPEN DRAIN (1 NTR) 5V	A7	I	Address	A7	3
B5	16	O	OPEN DRAIN (1 NTR) 5V	A8	I		A8	25
B6	17	O	OPEN DRAIN (1 NTR) 5V	A9	I		A9	24
B7	18	O	OPEN DRAIN (1 NTR) 5V	A10	I		A10	21
C0	20	I/O		DO	I/O		Q1	11
C1	21	I/O		D1	I/O		Q2	12
C2	22	I/O		D2	I/O		Q3	13
C3	23	I/O	Port C is a bidirectional data port	D3	I/O	DO - D7 are data I/O	Q4	14
C4	24	I/O		D4	I/O		Q5	15
C5	25	I/O		D5	I/O		Q6	16
C6	26	I/O		D6	I/O		Q7	17
C7	28	I/O		D7	I/O		Q8	18
DO	29	I/O		A11	I		A11	23
D1	30	I/O	Port D is a bidirectional data port	A12	I	EPROM	A12	2
D2	31	I/O		A13	I	Address	A13	26
D3	32	I/O		CHROM/XUROM	I			



## 8Bit Single Chip Microcontroller

DMC73C167

Normal Mode				EPROM Mode			TMC27C128	
Signal	Pin No.	I/O	Description	Signal	I/O	Description	Name	Pin No.
RED	33	O		-	-			
GREEN	34	O		-	-			
BLUE	35	O		-	-			
Yout	36	O	Active Low	-	-			
Hsync	37	I		EPTTESTHV	I		GND	14
Vsync	38	I		EPTTEST	I		GND	14
OSC1IN	43	I	CPU CLK-IN	GND	I	VSS	GND	14
OSC1OUT	44	O	CPU CLK-OUT					
XRESET	45	I	Device Reset	GND	I	VSS	GND	14
TEST	42	I	Device Test	VPP	I	PGM High Vtg	VPP	1
PWM0	1	O	14-bit PWM	XCE	I		XE	20
PWM1_0	2	O	6-bit PWM	-	-			
PWM1_1	3	O	6-bit PWM	-	-			
PWM1_2	4	O	6-bit PWM	-	-			
PWM1_3	5	O	6-bit PWM	-	-			
PWM1_4	6	O	6-bit PWM	-	-			
PWM1_5	7	O	6-bit PWM	-	-			
PWM1_6	8	O	6-bit PWM	-	-			
PWM1_7	9	O	6-bit PWM	-	-			
PWM1_8	10	O	6-bit PWM	-	-			
OSC2IN	39	I	OSD CLK-IN	-	-			
OSC2OUT	40	O	OSD CLK-OUT	-	-			
I2C DAT	51	I/O	I2C DATA (OPEN DRAIN)	XPGM	I		XPGM	27
I2C CLK	52	I/O	I2C CLK (OPEN DRAIN)	XOE	I		XG	22
VSS	27	I		VSS	I		VCC	28
VDD	54	I		VDD	I		GND	14

## Note 1 : Important Notice

A) EPTTESTHV pin assigned to Hsync, and EPTTEST pin assigned to Vsync.

EPTTEST	EPTTESTHV	OPERATION
0	0	PGM, PGM VERIFY, READ
1	0	WORD LINE STRESS, BIT LINE STRESS
1	1	OTHER FUNCTION TEST MODE

B) VPP pin assigned to TEST pad

C) ADDR (0 to 14) was assigned to APORT (1 - 7), BPORT (5 - 7), DPORT (0 - 3)

D) EPROM I/O data (8) was assigned to CPORT

## Note 2 : EPROM-related Pins

DATA LINE	8 pins
ADDRESS	15 pins (ADDR0 - ADDR13, CHROM/XUROM)
CONTROL	5 pins (XCE, XOE, XPGM, EPTTEST/HV)
VPP	1 pin
	29 pins
Other Pins	4 pins (XRESET, OSCIN, VCC, VSS)
Total	33 pins



## 6.1.1 Control Register of 73CE167 (OTP)

Table 6-1. P67 0143h Yout Polarity Control

Bit	7	6	5	4	3	2	1	0
R	Yout	Not Used						
W	POLARIT	Not Used						

**Bit 7** Yout Polarity. (R/W)  
 0 = No change High active.  
 1 = Changes polarity Low active.

Table 6-2. P77 014Dh APORT Pull-up TR Control Register

Bit	7	6	5	4	3	2	1	0
R	A7	A6	A5	A4	A3	A2	A1	A0
W	A7	A6	A5	A4	A3	A2	A1	A0

**A7 - A0** APORT Pull-up TR Control Data.  
 0 = Pull-up TR on.  
 1 = Pull-up TR off.

Table 6-3. P78 014Eh B/D PORT Pull-up TR Control Register

Bit	7	6	5	4	3	2	1	0
R	B7	B6	B5	B4	D3	D2	D1	D0
W	B7	B6	B5	B4	D3	D2	D1	D0

**B7 - B4** BPORT Pull-up TR Control Data.  
 0 = Pull-up TR on.  
 1 = Pull-up TR off.

**D3 - D0** DPORT Pull-up TR Control Data.  
 0 = Pull-up TR on.  
 1 = Pull-up TR off.



Table 6-4. P79 014Fh CPORT Pull-up TR Control Register

Bit	7	6	5	4	3	2	1	0
R								
W								
	C7	C6	C5	C4	C3	C2	C1	C0

76543210

Value After Reset 00000000

**C7 - C4** CPORT Pull-up TR Control Data.

0 = Pull-up TR on.

1 = Pull-up TR off.

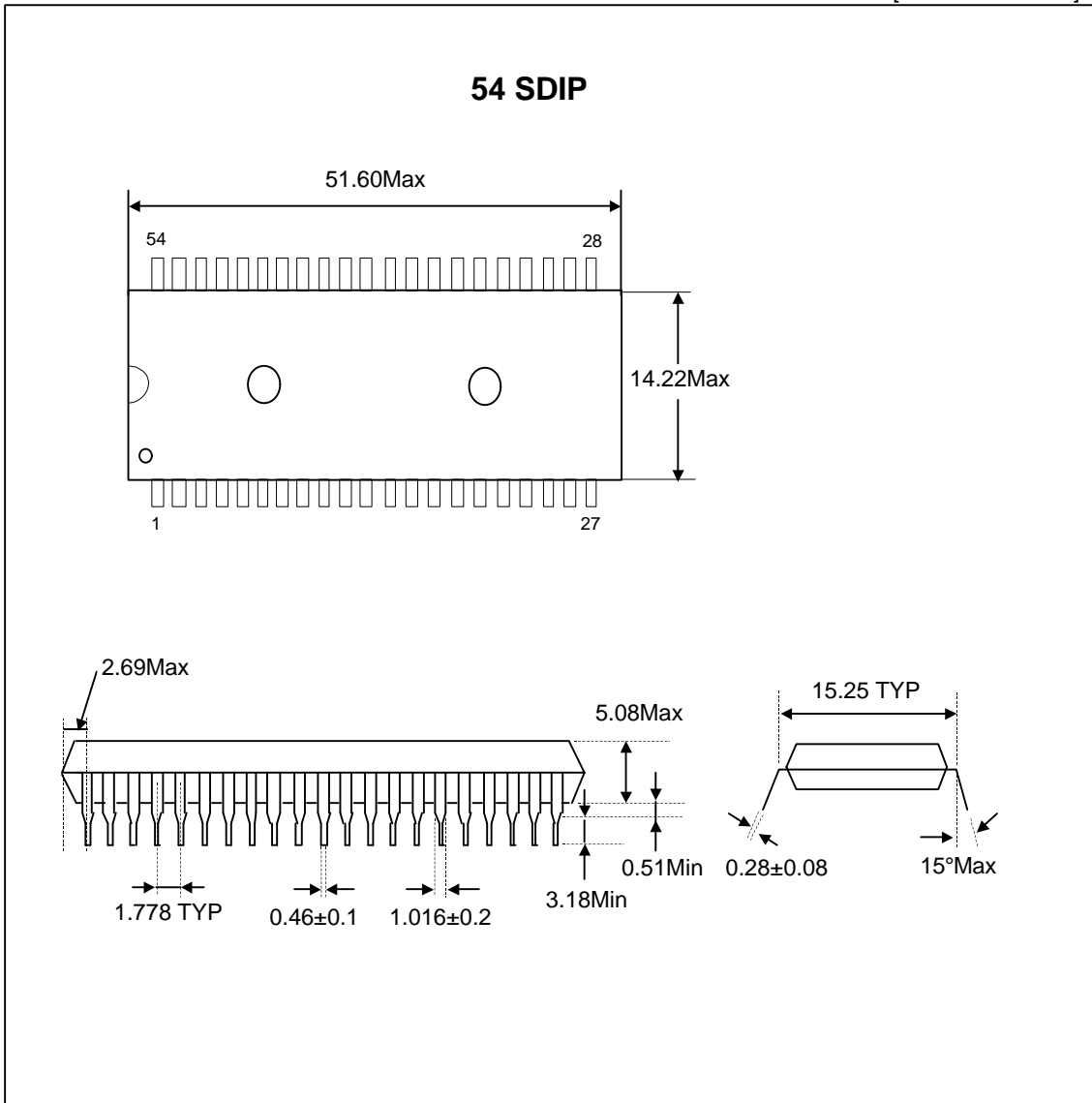
Note : After the reset values of the A/B/C/D pull-up control registers are all "00h", then all of pull-up TRs (=47K ohm) are connected to each pin by default. If the pull-up TRs are not needed, write FFh at P77, P78 and P79 to disconnect the pull-up TR first. Unwanted pull-up TRs can cause problems.



## 6.2 Package Descriptions (Mechanical Data)

Figure 6-2. 54-Pin Shrink Dual In-Line Package (SDIP)

[ UNIT : Milimeter ]





**\* Appendix : OSD Font Design Guide**

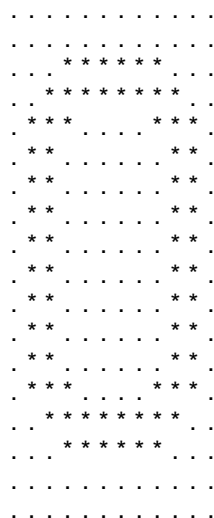
**1. OSD Font Create Rules for CTV Controller**

Subject : OSD Font Format for CTV Controller

Caution : User should make OSD fonts according to the following rules.

- Rule 1. User should only use dot (.) or the asterisk (\*) to make the OSD font.  
 The dot (.) represents ROM data '0' and asterisk (\*) represents ROM data '1' respectively.  
 Other symbols (except . and \*) should not be permitted.
  
- Rule 2. This Device has two OSD font types.  
 The font (Fig. 1) should be made by horizontal 12 symbol x vertical 18 symbol.  
 Don't be permitted to contain space or other symbol (except . and \*) in a OSD font.

Figure 1. OSD Font Form (Example)



- Rule 3. Between font to font horizontal space is permitted only one space.  
 Between font to font vertical space is permitted only one space and only one custom comment line as shown (Fig.2)
  
- Rule 4. This device has as following font numbers.  
 128 font + 2 dummy font : 5 char x 26 (Fig. 2)
  
- Rule 5. Outside of OSD font area should not be included any symbols.

Figure 2. OSD Font File made by user

