

# DG56C

automotive relays

# DURAKOOL



PCB version pictured

- High current automotive or industrial relays.
- Ideal for DC Motor Control and lamps
- Fans, winch & sunroof motors, vehicle alarms.
- Sn plated, copper terminals for high continuous DC current capacity.
- Industry standard Maxi-ISO terminals.
- PCB versions available.
- RoHS Compliant.

## Contacts

Contact number & arrangement	SPST-NO (1 Form A)
Contact material	AgSnO <sub>2</sub>
Max. switching voltage	DC 75V (current dependent). Contact factory for voltages above 24VDC
Contact rating (resistive)	70A (14VDC) 20A (24VDC)
Max. switching current (inrush) - make	120A
Rated power	980W
Min. switching current	100mA / 6VDC
Initial contact resistance	≤30mΩ, max. at 0.1A/6VDC (IEC 61810-7 / 4.12)

## Coil

Rated voltage	DC 6, 12, 24
Operating range of supply voltage	See coil table 1
Rated power consumption	2.3W (2.5W with resistor)

## Insulation

Insulation resistance	100MΩ at 500VDC, 50%RH, 25°C (IEC60255-5 / Item 7)	
Dielectric strength	coil to contact	500Vrms / 1 min 50Hz (IEC 60255-5 Item 6)
	contact to contact	500Vrms / 1 min 50Hz (IEC 60255-5 Item 6)

## General Data

Operating time	≤7ms	
Release time	≤5ms	
Electrical Life	ops 1 x 10 <sup>5</sup> (IEC61810-7 / Item 4.30)	
Mechanical life	ops 1 x 10 <sup>7</sup> (IEC61810-7 / Item 4.31)	
Dimensions	L x W x H 26.5 x 26.5 x 25.2mm (excluding terminals) - see drawings for more information	
Weight	36g approx. depending on style and mounting	
Ambient temperature	operating	-40 to 105°C (Derate above 85°C - consult factory)
	storage	-40 to 155°C
Shock resistance	Destructive	196m/s <sup>2</sup> (20g)
	Functional	30m/s <sup>2</sup> 6ms
Vibration resistance	DA 1.8mm, 20 to 500Hz	
Cover protection category	IP54 Dust cover, IP67 Fully sealed (optional)	

# DG56C

automotive relays



Coil Data						Table 1
Coil voltage code	Nominal voltage (VDC)	Coil resistance ( $\Omega \pm 10\%$ )	Must operate voltage max. (VDC)	Must release voltage min. (VDC)	Coil power consumption	Parallel Resistor ( $\Omega \pm 5\%$ (when fitted))
1006	6	15.7	3.6	0.6	2.3W	180
1012	12	62	7.2	1.2		680
1024	24	250	14.4	2.4		2700

## Ordering codes

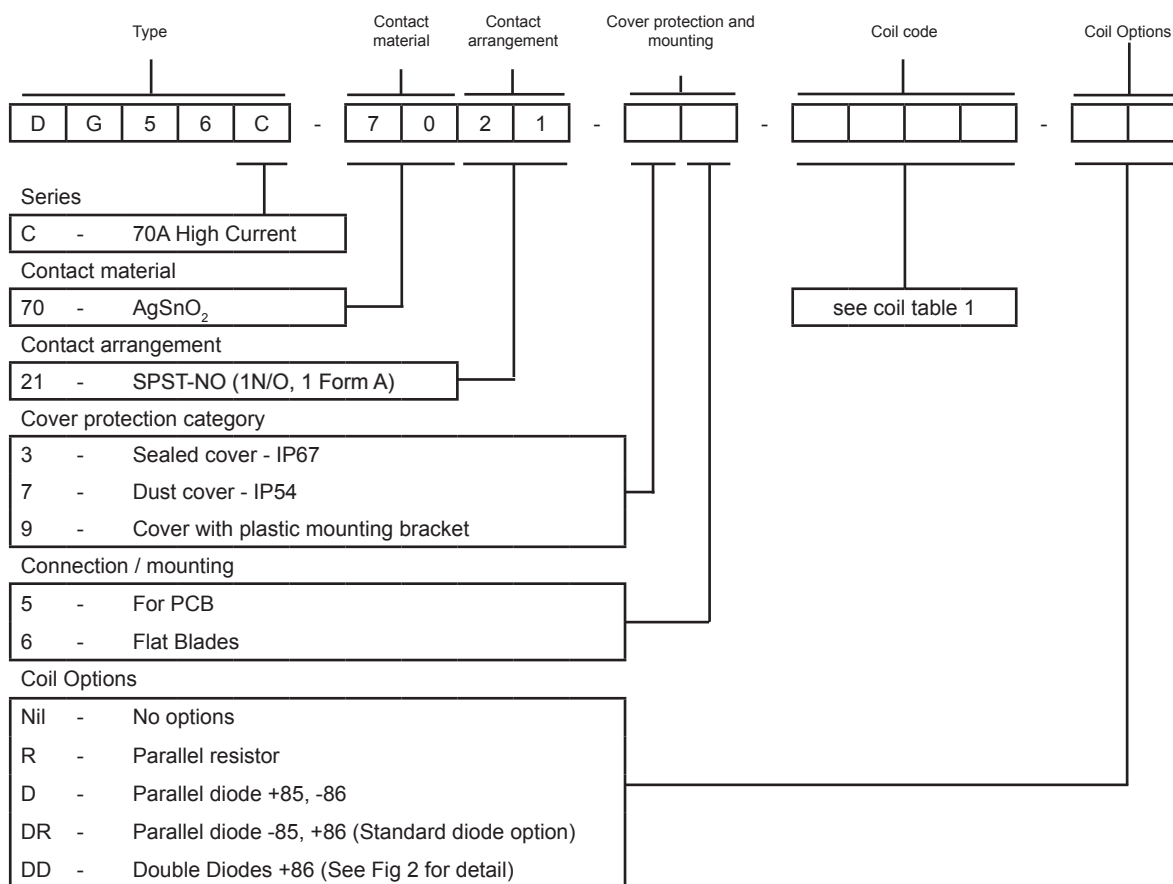

Overall Dimensions

Fig. 1

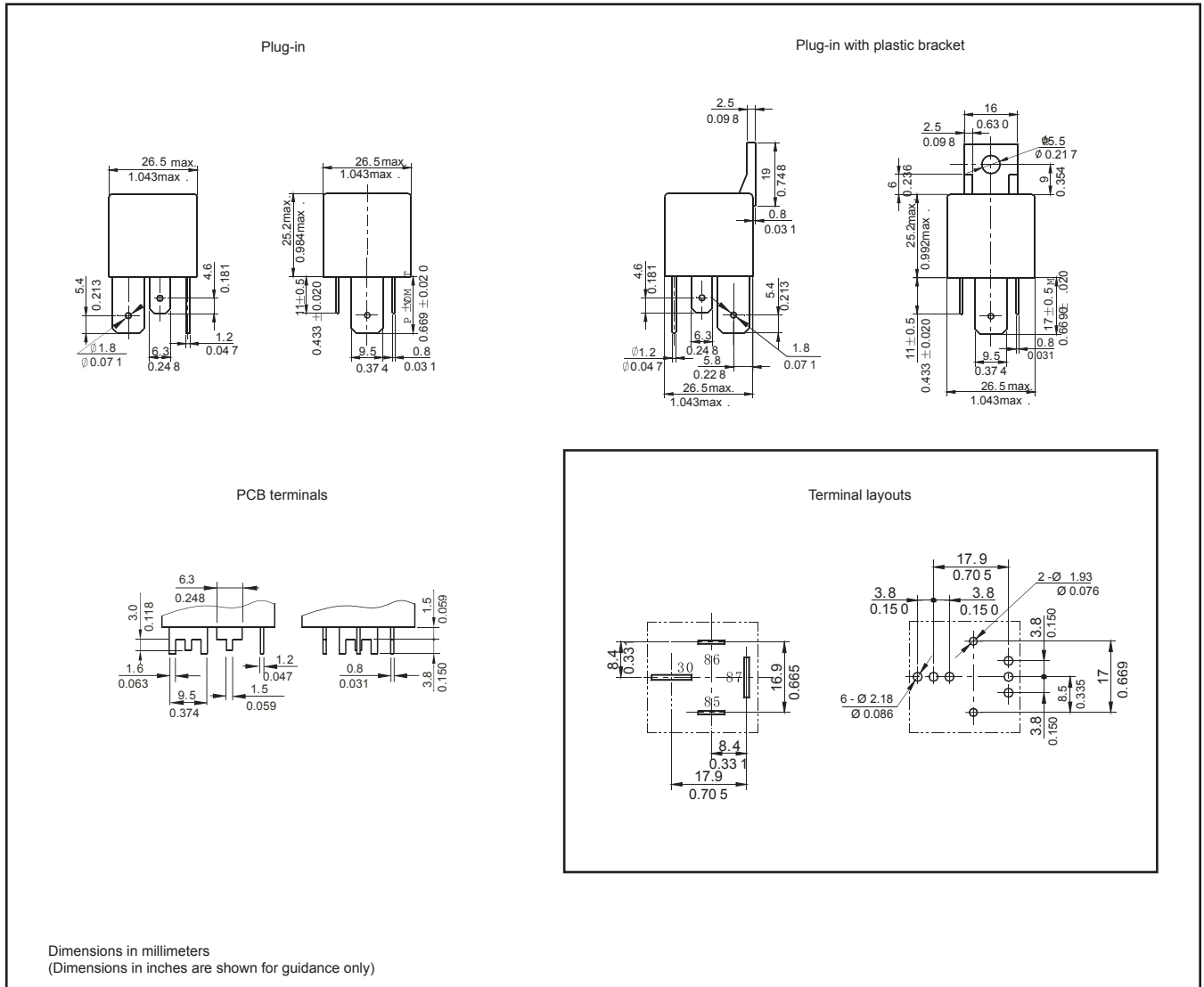

Connection diagrams

Fig. 2

