

Ultralow Power HD Voice Processors, Featuring SoundClear® Technology

Overview of Features

- Complete easy-to-implement voice solution including all essential voice, audio, and speech DSP features for flagship smartphones, tablets, and computing products
 - SoundClear Voice™ noise reduction, echo cancellation, and voice enhancement
 - RAPID2™ GUI-based diagnostic and tuning tool for ease of design-in
 - Media postprocessing support
 - Integrated Cirrus Logic playback enhancement for speakers and headphones
 - Optional Dolby® and DTS® playback enhancement ¹
- ASR Enhance™ automatic speech recognition (ASR) preprocessing for increased ASR accuracy in noisy environments
 - Voice activity detector (VAD) enables always-on speech recognition
 - TrulyHandsfree™ voice control by Sensory, Inc. supported
 - Powerful 130-MHz dual-MAC 32-bit DSP core
 - Ultralow power consumption (core typically <8 mW @ 1 V during narrowband call)
 - I²S, I²C, SPI™ digital connectivity

1. Use of TrulyHandsfree-, Dolby-, or DTS-supported features requires the existence and proof of a valid license agreement with the corresponding company to be able to use or distribute its technology in any finished end-user or ready-to-use final product.

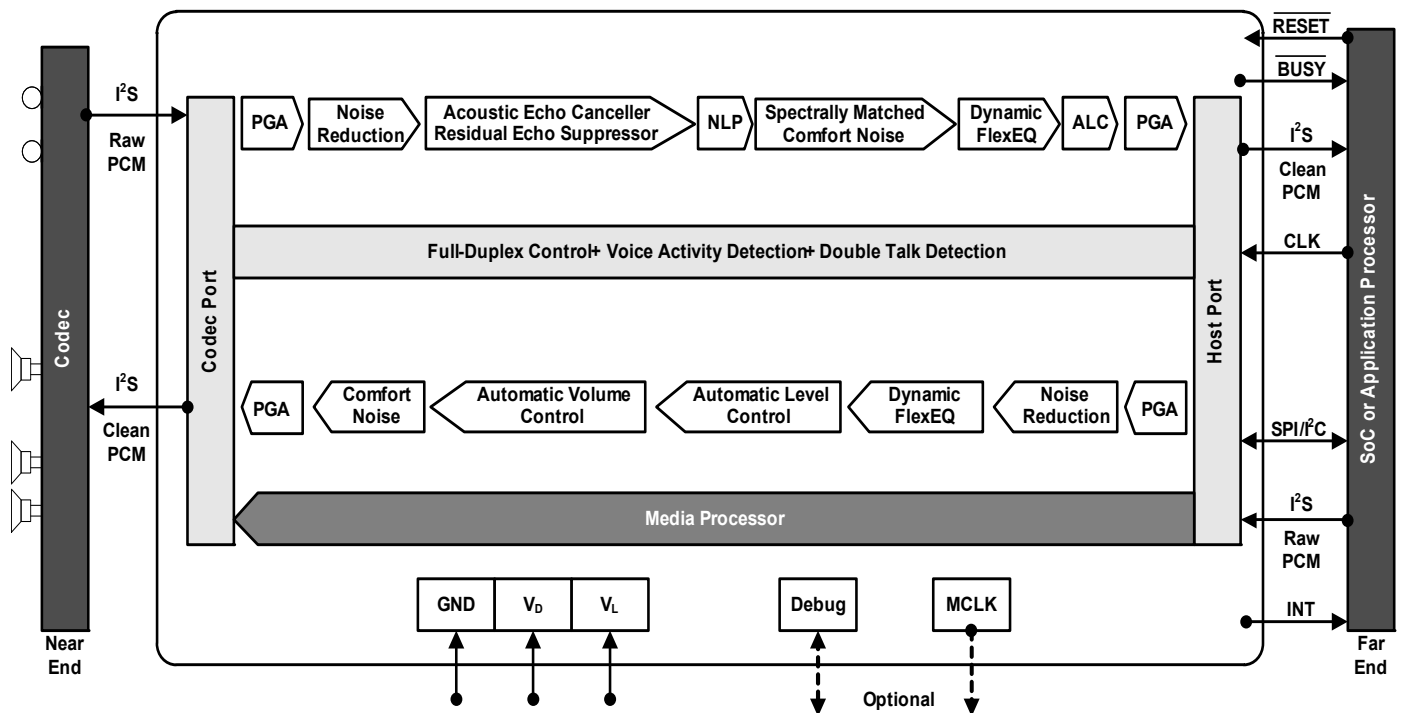

CS48LV12 Block Diagram

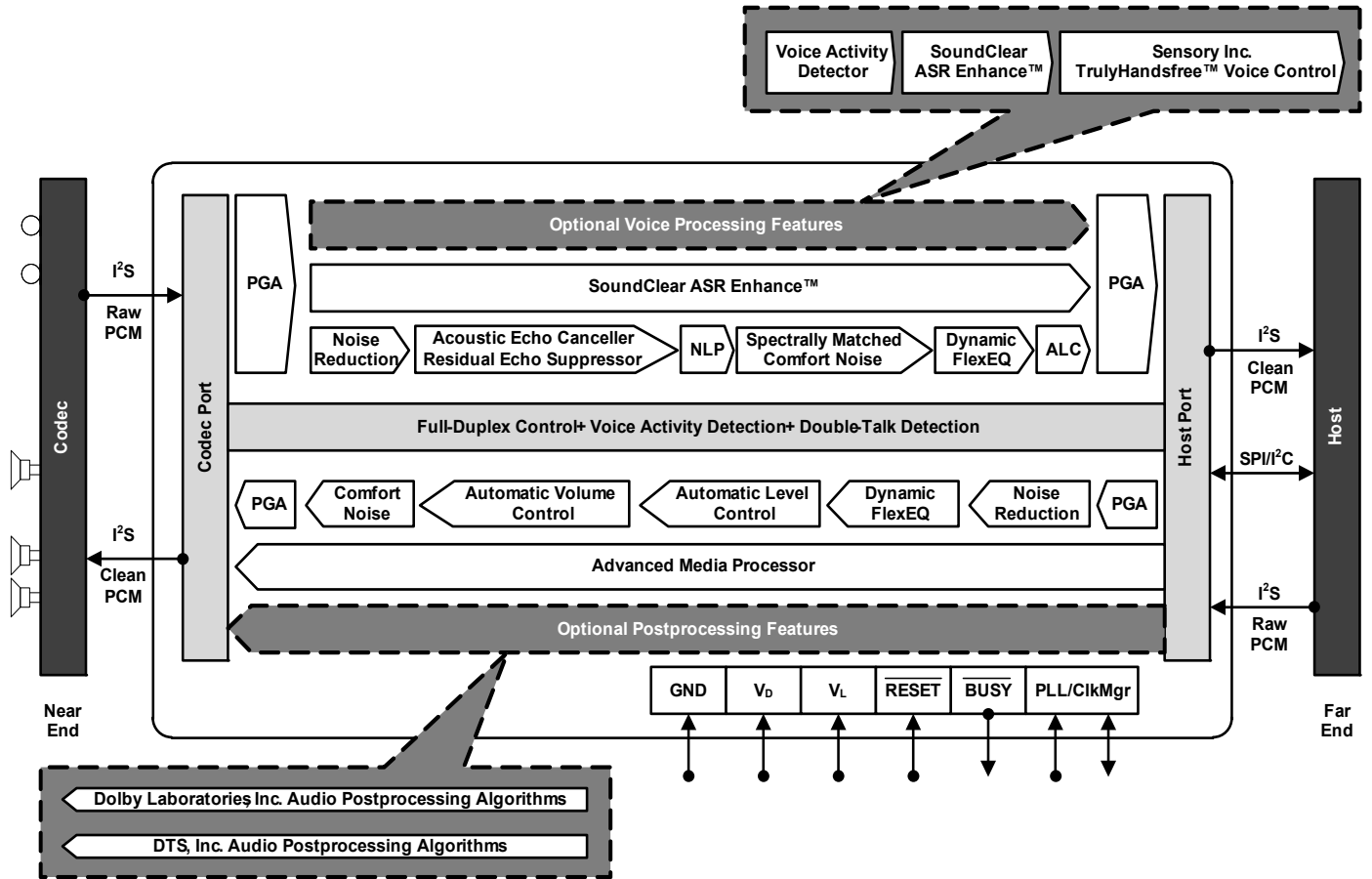

CS48LV13 Block Diagram

SoundClear Voice™ Features

- Flexible and tunable enabling freedom in product ID, transducer placement and selection
- Robust proprietary algorithms assure consistent performance across diverse sound environments and off-axis
- Ambient-aware technologies constantly compensate for changing noise types and level and varying product positioning
- HD voice/wideband and narrowband support
- Supports handset, tablet, laptop, and speakerphone single and multiple microphone configurations
- Conference room-grade AEC plus nonlinear residual echo suppressor for superior full-duplex speakerphone operation without echo
- Tx and Rx noise elimination
- Automatic volume control for both Tx and Rx compensates variations in talker level, proximity, and orientation
- Ambient-aware volume control compensates for variation in Rx voice level and near-end noise level
- Tx and Rx comfort noise generators provide natural, smooth transitions between single-talk Rx, single-talk Tx, double-talk, and silent states

- Tx spectrally matched comfort-noise generator samples and synthesizes ambient noise for more transparent talk state transitions
- Tx and Rx parametric EQ simplifies carrier and industry compliance, achieving natural sound and compensating for transducer limitations
 - Up to four concurrent Tx and four concurrent Rx filters
 - Eight different filter types can be combined to achieve exact requirements
 - Each filter has tunable frequency, gain, and Q or bandwidth
- Ambient-aware dynamic parametric EQ for Tx or Rx enables automatic real time tuning for improved intelligibility and to compensate for transducer characteristics; responds to
 - Tx or Rx stream amplitude
 - Near-end ambient noise level
 - User controls
- Rx compander for optimal speaker output level
- Mixed and mismatched microphone compensation
- Automatic calibration for up to ±6-dB sensitivity variation
- Compensation for microphone phase differences

Cirrus Logic Speech Features (CS48LV13 Only)

- ASR Enhance preprocessor for ASR engines
 - Improves speech command recognition of ASR engines in noisy environments
 - Can be applied with VAD described below and optional TrulyHandsfree voice control and/or cloud based ASR

Optional Speech Features Supported (CS48LV13 Only) ¹

- Sensory TrulyHandsfree voice control
- Complete always-on local ASR solution
 - Ultralow power always-on Cirrus Logic voice detection (VAD)
 - ASR Enhance pre-processor increases ASR accuracy in noisy conditions
 - TrulyHandsFree voice trigger and voice command

Audio Playback Features

- Full complement of Cirrus Logic audio-processing algorithms preintegrated to enhance mono or stereo playback over speakers or headphones
 - Virtual surround
 - Bass enhancement
 - Bass virtualization
 - Parametric EQ
 - Multiband compressor
- Graphical interface for selection and tuning of algorithms

Optional Audio Playback Features Supported (CS48LV13 Only) ¹

- Dolby® postprocessing (enhancement and virtualization)
- DTS® postprocessing (enhancement and virtualization)
- Headphone and speaker playback support

Applications

The CS48LV12/13 provides a complete voice, audio playback and speech preprocessing solution for smartphone, tablet, laptop, headphone/headset, and speaker/speakerphone applications. They are optimized for devices where pristine voice quality and echo-free, full-duplex communication is required, especially under conditions of adverse noise and where space and power are limited.

¹. Use of TrulyHandsfree-, Dolby-, or DTS-supported features requires the existence and proof of a valid license agreement with the corresponding company to be able to use or distribute its technology in any finished end-user or ready-to-use final product.

General Description

The CS48LV12 and CS48LV13 ultralow power voice processors feature Cirrus Logic's patented SoundClear® technology to provide a new standard in HD Voice quality performance, functionality, and cost effectiveness. These ICs provide a total voice processing solution for handset and hands-free communications that deliver best-in-class noise reduction, echo cancellation, and speech recognition. The CS48LV12 and CS48LV13 can enable advanced features including always-on voice trigger, command recognition, ASR pre-processing, and audio enhancement. Innovative single and multi-mic algorithms with intelligent speech tracking and noise elimination assure optimal user experience in the most challenging and dynamic noise environments and deliver superior performance despite varying speech levels, talker distance, or product orientation.

The CS48LV12 and CS48LV13 feature an integrated media processor with built-in virtual surround, bass enhancement, bass synthesis, multi-band compression, and parametric EQ algorithms to enrich music playback through wireless speakers and headphones. All are tunable through a simple GUI. In addition, the CS48LV13 provides the option of adding a Cirrus Logic proprietary Voice Activity Detector for always-on ASR capability and integrated TrulyHandsfree™ Voice Control. Also available is Cirrus Logic's ASR Enhance™ specialized preprocessor to enhance the accuracy of any ASR (Automatic Speech Recognition) engine under noisy conditions. An expanded menu of third-party media playback algorithms from Dolby and DTS can also be integrated. Powerful real-time diagnostic and tuning tools combined with specialized labs and a global applications support network assure ease of design, optimal performance, and achievement of network and industry compliance.

1 Documentation

This document describes the CS48LV12 and CS48LV13 HD voice processors. When evaluating or designing a system around the CS48LV12/13 processors, use this document in conjunction with the documents listed in [Table 1-1](#).

Table 1-1. CS48LV12/13 Related Documentation

Document Name	Description
<i>CS48LV12/13 Data Sheet</i>	This document
<i>RAPID2™ User's Guide</i>	Instructional manual for using the RAPID2 tool for voice processing diagnostics and tuning
<i>DSPComposer™ User's Manual for CS48LV12/13</i>	Manual for using the CS48LV12/13 version of DSP composer™ tool for post-processing configuration and tuning
<i>CS48L10 Hardware User's Manual</i>	Includes detailed system design information including typical connection diagrams and boot procedures applicable for CS48L10/L11/LV12/LV13
<i>CRD48L10 4in4out Board Manual</i>	Manual for development and evaluation board for CS48L10/L11/LV12/LV13
<i>Micro-condensers User's Guide</i>	Instructional manual for using Micro-condenser for creating microcode and flash image for embedded systems applications
<i>AN344</i>	Firmware User's Manual for CS48L10/L11/LV12/LV13
<i>AN344CBE</i>	Applications note for Cirrus Bass Enhancement (CBE) Module
<i>AN344CBV</i>	Applications note for Cirrus Bass Virtualization (CBV) Module
<i>AN344CVT</i>	Applications note for Cirrus Virtualization Technology (CVT)
<i>AN344EQ</i>	Applications note for Cirrus Equalization (EQ) Module
<i>AN344TC</i>	Applications note for Tone Control Post-processor Module

The primary scope of this document is to provide the hardware specifications of the CS48LV12/13 family of devices. These include hardware functionality, characteristic data, pinout, and packaging information. The intended audience includes system PCB designers, MCU programmers, and quality-control engineers.

2 Overview

The CS48LV12 and CS48LV13 products are based on Cirrus Logic 32 bit fixed point DSP's which feature the ultralow power, tiny foot print, high performance and low cost that is required by today's mobile voice communication products. For ease of implementation and high computational efficiency, each product includes an embedded software package highly optimized for the DSP. Designed into each product is the ability to support multiple modes and configurations that match an array of product use models for smartphones, tablets, and mobile computing devices as well as a variety of consumer and automotive products with hands-free communication features.

The CS48LV12 incorporates Cirrus Logic SoundClear technology to perform all voice processing functions typically required in handset and hands-free products including noise reduction, echo cancellation, and a comprehensive set of voice enhancement capabilities. SoundClear technology uses proprietary algorithms to decipher spatial and spectral characteristics of both the Rx (far-end) and Tx (near-end) digital voice streams and categorize various types of noise and speech, removing noise and competing talkers while automatically adjusting for SPL changes, changes in product position and orientation, and ongoing environmental changes. Other SoundClear modules monitor talk status (single Tx, single Rx, silence, double-talk), cancel echo, suppress residual echo, and inject comfort noise if required to achieve natural, consistent, full-duplex, echo-free conversation, in both hand-set and hands-free modes.

The CS48LV12 also includes integrated media processing capabilities to enhance audio playback over internal speakers or attached devices such as speakers and headphones.

The CS48LV13 includes all the voice and media processing capabilities as well as ASR pre-processing (ASR Enhance) to remove noise that limits ASR accuracy and reliability. It also includes a specialized Voice Activity Detector (VAD) that enables the CS48LV13 to remain in a very low power "always-on" state until the VAD detects human speech in the proximity of a microphone. This feature is typically used in conjunction with a local ASR solution such as the CS48LV13's optional Sensory TrulyHandsfree voice control.

The CS48LV13 also supports several optional features requiring third party licenses:

- Sensory, Inc. TrulyHandsfree voice control
- Dolby, Inc. media playback enhancement algorithms
- DTS, Inc. media playback enhancement algorithms

A key feature of both products that enables ease of implementation, quick time to market and performance optimized to a particular ID is the RAPID2 diagnostic and tuning tool. This Microsoft Windows® based tool provides GUI based monitoring and control of all critical SoundClear parameters as well as system level measurements and statistics. RAPID2 tool features are described in [Section 3.16](#).

2.1 Licensing

Licenses are required for any third-party audio-processing algorithms, including but not limited to Sensory, Inc. TrulyHandsfree™ and Dolby and DTS postprocessing solutions provided for the CS48LV12/13. A Cirrus Logic royalty free license is also required to distribute product containing the CS48LV12 or CS48LV13 embedded software packages required for functionality described in this data sheet. Contact your local Cirrus Logic Sales representative for more information.

3 Functional Description

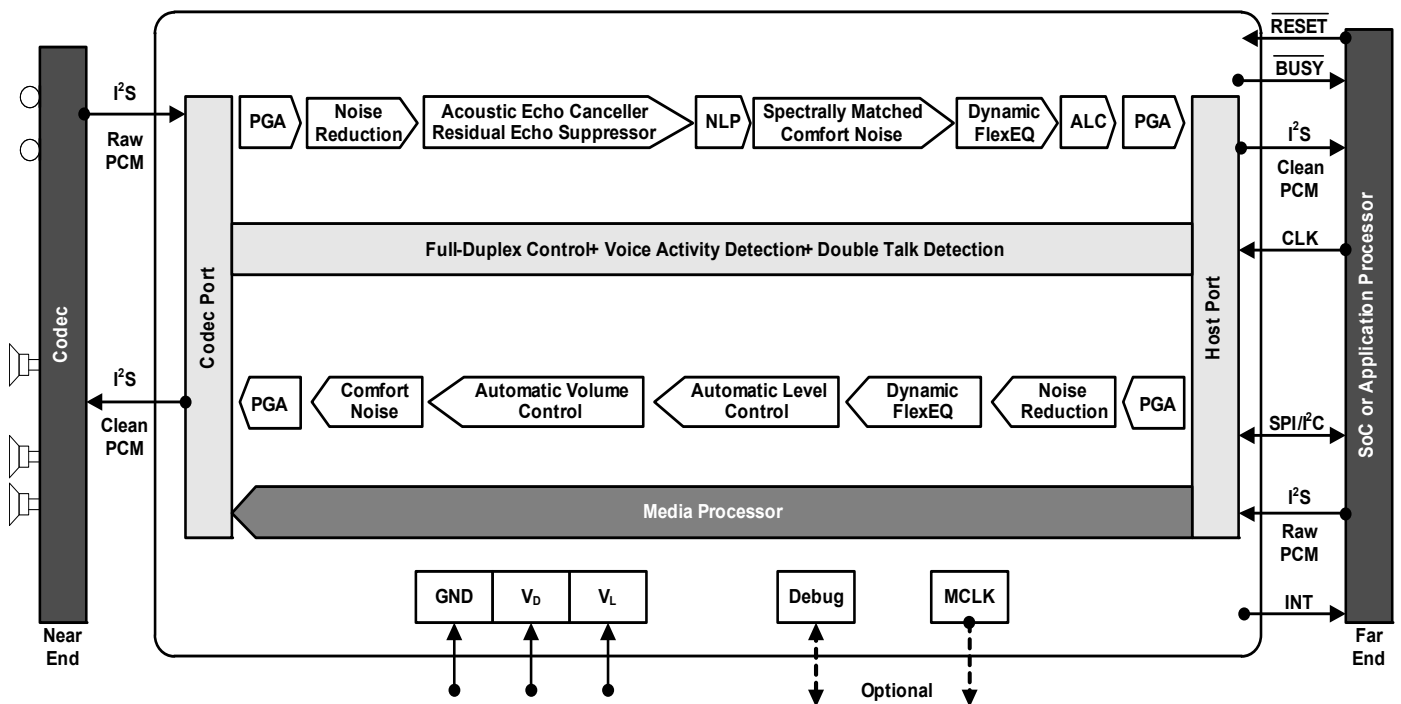

Figure 3-1. CS48LV12 Block Diagram

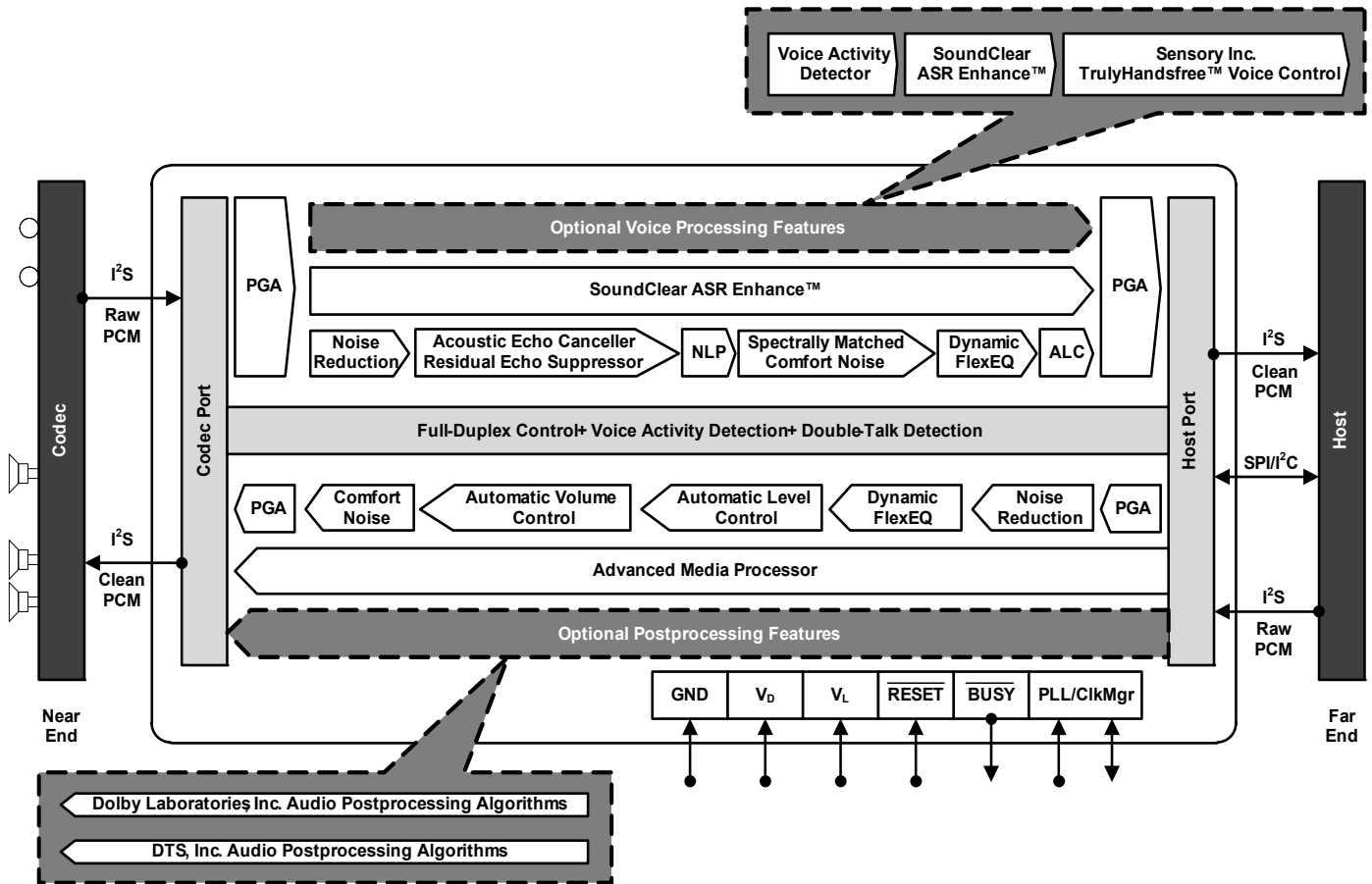

Figure 3-2. CS48LV13 Block Diagram

3.1 Cirrus Logic 32-bit DSP Core

The core is a high-performance, 32-bit, fixed-point DSP that is capable of performing two multiply-and-accumulate (MAC) operations per clock cycle. The core has eight 72-bit accumulators, four X- and four Y-data registers, and 12 index registers. It can operate up to 130 MHz, depending on mode and concurrency requirements, but it may also operate at low speed to support specialized low-power modes, such as always-on voice wake.

The DSP core is coupled to a flexible DMA engine. The DMA engine can move data between peripherals such as the multi-channel serial audio port, or any DSP core memory, without the intervention of the DSP. The DMA engine off-loads data move instructions from the DSP core, leaving more MIPS available for signal-processing instructions.

3.2 Processing Groups

Providing consistent high-quality Tx and Rx voice streams in constantly changing environments requires a complex data flow with constant interaction between various functional modules. While the actual data flow is more complex and not linear, the architecture can be approximated as a set of in-line processing groups or chains that operate in different modes depending on the current use model as follows.

CS48LV12:

1. Tx Voice DSP Chain
2. Rx Voice DSP Chain
3. Voice DSP Control and Detection
4. Audio Playback DSP Chain

The CS48LV13 includes two additional processing groups:

5. Speech DSP Chain
6. Advanced Audio Playback DSP Chain

Cirrus Logic provides two specialized tools for controlling and tuning the various processing groups. For voice- and speech-related processing groups, the RAPID2 tool provides real-time analysis and tuning of all parameters. For audio-playback chains, a specialized version of the DSP Composer tool is used for real-time control and tuning.

Each group may operate in more than one mode. Typically, smartphones have three or more operating modes:

- a) Handset mode using processing Groups 1, 2, and 3
- b) Speakerphone mode using processing Groups 1, 2, and 3
- c) Media playback mode using processing Group 4 or 6
- d) ASR mode using process using Group 5

Each mode may have tuning variations; for example, handset mode may include default tuning (using integrated microphones and receiver), pass-through tuning for BT accessories, which perform their own voice processing and wired headset tuning.

Tablets may have a single mode, similar to Speakerphone Mode, or may have multiple modes using different microphones and processing, depending on their orientation and desired use model, such as portrait, landscape, handheld, on stand, personal or group. Similarly, other applications may have a single or multiple modes using one or more processing groups.

3.3 Tx Voice DSP Chain

The Tx Voice DSP Chain accepts raw PCM voice data from one or two microphones and uses this data, along with any incorporated spatial information, to remove undesired noise and competing speech while preserving voice integrity. It also includes AEC and residual echo suppression functions to remove echo. In combination with the Voice DSP Control and Detection and Rx Voice DSP Chain groups, it manages full-duplex operation. A number of additional voice processing blocks are included to provide a natural, intelligible, and consistent PCM voice stream.

Fig. 3-3 is a simplified diagram of the Tx Voice Chain. The start of the chain is fed by one or two voice PCM streams originating from the voice microphones and arriving on one of the CS48LV12/13's two I2S DAI inputs (typically DAI_2). The output of the chain, Tx Out, is transmitted out of one of the two I2S DAO outputs (typically DAO_1), typically a host processor, applications processor, or system on a chip (SoC), which then sends the stream to a digital baseband or other network processor.



Figure 3-3. Tx Voice DSP Chain

3.4 Programmable Gain Amplifiers (PGAs)

One set of PGAs controls the level of the input streams from the mic and another PGA at the output of the chain controls the level of the output stream (Tx Out). The RAPID2 tool includes PGA level meters with clipping detectors can be used to adjust PGA gain level to maintain maximum SNR without danger of clipping.

3.5 Noise Reduction

SoundClear Voice technology uses a variety of innovative techniques and algorithms to distinguish between desired speech, undesired speech (competing talkers), and nonspeech, and then suppresses all but desired speech.

In a two-mic configuration, SoundClear Voice technology uses signature analysis techniques to distinguish and eliminate noise and to preserve the vocal quality of speech. Also, a proprietary beam forming technology analyzes the aural space around the user and classifies sounds, based on direction of arrival and proximity. It also makes real-time voice-tracking

adjustments to compensate for changes in device orientation. This results in better off-axis performance than do traditional techniques with fixed acceptance angles. The noise-reduction block uses highly adaptive spatial analysis, spectral analysis, and audio classification to quickly adjust for changes in audio environment and talker position.

Simple adjustments made through the RAPID2 tool allow the noise reduction block to be optimized for a variety of microphone spacing and placements. Tightening standards on signal-to-noise-level improvement (SNRI) and voice quality require careful balance to assure compliance and quality user experience. The RAPID2 tool provides the granularity of control required to optimize user experience and compliance.

3.6 Acoustic Echo Cancellation (AEC)

In principle, the AEC works by recognizing the Rx signal that reappears, with some delay, in the Tx signal being processed for transmission. Before transmission, the echo is removed by subtracting or canceling it out. In reality, canceling all perceptible echo while maintaining full-duplex communication requires a complex set of monitoring control and digital DSP algorithms. The CS48LV12/13's AEC in combination with the Voice DSP Control and Detection group can provide conference room–grade speakerphone performance within the performance constraints of the transducers used. However, achieving high quality, full-duplex, echo-free performance in both handset and handsfree/speakerphone modes requires conscientious system-level attention before completing component selection and design. Contact your Cirrus Logic sales representative regarding available technical support early in the product-design process.

3.6.1 Residual Echo Suppressor/Nonlinear Processor

These blocks identify and suppress any nonlinear echo components not canceled by the AEC. The residual components include distortion commonly introduced by small transducers, such as those used in mobile devices and is critical to achieving a clean-sounding echo-free Tx voice stream.

3.7 Spectrally Matched Comfort Noise Generator (CNG)

Full-duplex communication can be classified into four possible states:

- Silence (neither the near- nor the far-end talker is speaking)
- Single-Talk Rx (only the far-end talker is speaking)
- Single-Talk Tx (only the near-end talker is speaking)
- Double-Talk (both talkers are speaking simultaneously)

During the Single-Talk Rx state, the AEC suppresses the Rx signal to eliminate all echo when no near-end voice is detected. This can cause the person on the far end to perceive modulation between hearing ambient far-end noise and then silence. To avoid this, the CNG samples ambient noise, synthesizes it, and injects it into the Tx stream whenever there is silence, providing the far-end listener with a more natural, constant audio experience.

3.8 Dynamic PEQ

Cellular providers and industry standards require that Tx frequency response conforms to a tight envelope. Furthermore, compensating for transducers characteristics and achieving natural voice character may require significant parametric equalization of the Tx voice stream. This block provides up to four concurrent filters, each of which can be defined as one of eight different filter types that can be combined to achieve exact frequency response requirement. Each filter has tunable frequency, gain, and Q or bandwidth. The following filter types are available: low pass, high pass, low shelf, high shelf, band pass, peaking, notch, and all pass.

In addition to functioning as a traditional parametric equalizer, this block can be operated in Ambient Aware Mode, where EQ settings are automatically adjusted in real time, based on either loudness or noise levels. This feature can be used to improve intelligibility under noisy conditions or maintain natural sound over changing loudness levels.

The dynamic PEQ block is the same for both the Tx and Rx voice DSP chains.

3.9 Automatic Level Control (ALC)

Tx voice level can vary greatly based on talker loudness, product distance and orientation. By distinguishing between voice and noise levels and adjusting Tx voice level accordingly, the ALC is able to maintain more consistent Tx voice loudness without boosting noise in periods of silence. This improves far-end user experience and product performance when it is held away from the mouth or off-axis.

3.10 Rx Voice DSP Chain



Figure 3-4. Rx Voice DSP Chain

Table 3-1 describes the functions in the Rx voice DSP chain.

Table 3-1. Rx Voice DSP Chain Descriptions

Function	Description
Programmable gain amplifiers (PGAs)	One set of PGAs controls the level of the input streams from the host downlink (Rx). Another PGA at the output of the chain controls the level of the output stream (Tx Out). The RAPID2 tool includes PGA level meters with clipping detectors that can be used to adjust PGA gain level to maintain maximum SNR without danger of clipping.
Noise reduction	Similar function as Noise Reduction in Tx Voice Chain, but operating on more limited information, because the Rx stream from the far-end uses a single channel and lacks the spatial information necessary to perform the high levels of SNRI achieved by the multi-mic algorithms applied to the Tx stream. However, the Rx noise-reduction function can significantly suppress far-end noise, especially stationary-type noises.
Dynamic (PEQ)	This block is the same for both the Tx and Rx Voice DSP chains. See Section 3.8 .
Automatic level control (ALC)	Rx voice level can vary greatly, based on the far-end talkers loudness and on the phone's orientation. By distinguishing between voice and noise levels and by adjusting Rx voice level accordingly, the ALC can maintain more consistent Rx voice volume, without boosting noise during silent periods. This improves near-end user experience and product performance when a far-end talker speaks softly or holds the phone away from their mouth.
Automatic volume control (ALC)	As ambient noise level rises, it can be more difficult for the user to understand the caller, regardless of whether the product is being used in handset or hands-free/speakerphone mode. The ALC block automatically adjusts receive loudness, based on ambient noise level.
Comfort noise generator (CNG)	CNG is used to inject levels of synthesized noise into the Rx stream during periods of silence, so that the near-end user avoids hearing noise modulation.

3.11 Voice DSP Control and Detection Group

The voice DSP control and detection group encompasses several functions related to managing the combined Tx and Rx Voice DSP Chains. Key functions include full-duplex communication state control, voice detection, noise classification, AEC, and residual echo-suppression control.

3.12 Audio Playback DSP Chain/Advanced Audio Playback DSP Chain

This chain consists of various audio postprocessing modules for enhancement of media playback. The modules have multiple use modes for support of both integrated speakers and plug-in headphones. Both the CS48LV12 and CS48LV13 integrate the following Cirrus Logic algorithms:

- Virtual surround
- Bass enhancement
- Bass virtualization
- Parametric EQ
- Multiband compressor

A special version of Cirrus Logic® DSP Composer tool enables selection of the desired combination of algorithms and their tuning.

Optionally, the CS48LV13 supports popular postprocessing algorithms from Dolby and DTS. A license agreement with Dolby or DTS is required to use this feature. DSP composer support for these algorithms is also available.

3.13 Speech DSP Chain

The CS48LV13 includes Cirrus Logic ASR Enhance preprocessor that removes noise impacting ASR engine performance. SoundClear ASR Enhance algorithms use specialized spatial NR techniques to improve command success rate by accomplishing the following:

- Reducing near-end noise that masks speech pauses and otherwise interferes with accuracy
- Suppressing cross-talk from competing talkers in the vicinity
- Preserving voice spectral content
- Preventing phoneme degradation
- Using InstantAdapt™ noise adaption to avoid missed or truncated commands

The ASR Enhance preprocessor can be used to improve local ASR performance including the optional Sensory TrulyHandsfree voice control as well as cloud based engines.

The CS48LV13 supports an optional speech chain, which can include the following functions:

- Cirrus Logic voice activity detector (VAD). This specialized VAD enables always-on ultralow-power voice trigger. The VAD constantly monitors ambient sound while the CS48LV13 is in a very low power state. If it detects voice, the VAD can trigger the supported Sensory TrulyHandsfree voice control engine running on the CS48LV13.
- Sensory TrulyHandsfree voice control. When the VAD has detected a voice, it can trigger TrulyHandsfree to detect a predefined wake-up command. If it detects the proper command, it enters Voice-Command Mode to interpret any command within its vocabulary. If the proper wake-up command is not detected, the device can return to its always-on VAD mode.

3.14 On-chip DSP Peripherals

3.14.1 I²S Digital Audio Ports

3.14.1.1 I²S Digital Audio Input Ports (DAI)

Two DAI ports support PCM format with word lengths up to 32 bits and sample rates as high as 192 kHz. DAI_1 is typically connected to a host processor, applications processor, or mobile SoC to receive Rx voice and audio data. DAI_2 is typically connected to a codec or A/D streaming Tx voice or audio data captured from microphones. Both ports operate in I²S slave clock mode using SCLK and LRCLK for bit-clock and word select. For voice (call) modes, both DAI ports use a 16-bit word length, a 8-KHz sample rate for narrowband calls, and 16-KHz sample rate for HD voice/wide-band calls. Rx (downlink) requires one channel and Tx (requires one or two channels), depending on microphone/input mode. For playback mode, other audio formats are supported, based on the content type and postprocessing algorithms applied.

3.14.1.2 I²S Digital Audio Output Port (DAO)

Two DAO ports support PCM format with word lengths up to 32 bits and sample rates as high as 192 kHz.

DAO_1 is typically connected to a host processor, applications processor or mobile SoC to transmit Tx voice and audio data. DAO_2 is typically connected to a codec, D/A, or digital amp streaming Rx voice or audio data out to transducers such as mobile phone receiver, speakers, or headphone. Both ports operate in I²S slave clock mode using SCLK and LRCLK for bit clock and word select. For voice (call) modes both DAO ports will use a 16-bit word length, 8-KHz sample rate for narrowband calls, and 16 KHz for HD voice/wide-band calls. For playback mode, other audio formats are supported based on the content type and postprocessing algorithms being applied.

3.14.2 Serial Control Port (I²C or SPI)

The on-chip serial control port is capable of operating as slave in either I²C or SPI modes. Slave operation is chosen by a mode select pin when the CS48LV12/13 comes out of reset. The serial clock pin can support frequencies as high as 25 MHz in SPI mode.

The slave SPI clock speed must always be \leq (DSP Core Frequency/2).

The serial control port also includes a pin for flow control of the communications interface ($\overline{\text{BUSY/I2C_SELECT}}$) and a pin to indicate when the DSP has a message for the host ($\overline{\text{INT}}$).

3.14.3 PLL-based Clock Generator

The low-jitter PLL generates integer or fractional multiples of a reference frequency, which are used to clock the DSP core and peripherals. Through a second PLL divider chain, a dependent clock domain can be output on the DAO port for driving audio converters. The CS48LV12/13 defaults to running from the external reference frequency and is switched to use the PLL either through a boot command from the host or by the firmware running on the DSP.

3.15 Power Management

Several control registers and bits provide independent power down control of the RAM, ROM, PLL and internal clock domains, allowing operation in select applications with minimal power consumption. Each RAM bank (4 K word) and each ROM bank (8 K word for code, and 4 K word for data) can be powered on or off individually. After a hardware reset, all the memory banks are powered on.

The Host in the system can initiate a low-power mode for the DSP core to conserve system power when audio processing is not required. The firmware API provides different levels of low-power mode, which allows each system to customize the power consumption and wake-up protocol to its needs.

3.16 RAPID2™ Real-Time Diagnostic and Tuning Tool

This real-time interactive GUI-based program provides both control and monitoring of all critical SoundClear Voice DSP functions. It enables users to optimize algorithmic performance to match design characteristics such as transducer type and placement, mechanical and electrical design, and acoustic properties. It is both a system level diagnostic and tuning tool that is used to achieve performance goals as well as industry, carrier, and OEM compliance. Its capabilities include:

- Meter monitoring including peak and clip detection for:
 - Mic inputs
 - Tx line out
 - Rx line in
 - Rx speaker out
- Dual-axis tickertape graphic monitoring
 - AEC performance
 - AEC input and AEC output
 - Audio mode
 - Mic 1 and mic 2
 - Speaker out
 - Line in and line out
- Automatic system-level measurements
 - Bulk delay
 - ENR—Echo to near-end ratio
 - ERLE—Echo return loss enhanced
- Statistical measurements included
 - Channel noise levels
 - Channel amplitude levels
 - Clip occurrences
- Real-time control of all SoundClear parameter sets
 - All programmable gain amplifiers (Tx in, Tx out, Rx in, Rx out)

- Multi-mic noise reduction
- Single-mic noise reduction
- Audio detection and classification
- AEC, including path-change detection
- Nonlinear residual echo suppression
- Tx and Rx automatic level control
- Tx and Rx parametric EQ (with graphical interface)
- Rx automatic volume control
- Speaker out compander
- Double-talk detection
- Voice activity detection
- Tx and Rx comfort noise generation

4 Characteristics and Specifications

4.1 Absolute Maximum Ratings

GND = 0 V; all voltages with respect to ground.

Parameters	Symbol	Min	Max	Units	
DC Power Supply	DSP Core/Memory/PLL	VD, VPLL	-0.3	1.5	V
	Serial/Control	VL	-0.3	4.0	V
Input Current ¹	I_{in}	—	10	mA	
External Voltage Applied to Digital Input ²	V_{IND}	-0.3	$V_L * 1.2$	V	
Storage Temperature	T_{stg}	-65	+150	°C	

1. Any pin except supplies. This value is characterized not tested.

2. The maximum over/under voltage is limited by the input current.

WARNING: Operation at or beyond these limits can result in permanent damage to the device.

4.2 Recommended Operating Conditions

GND = 0 V, all voltages with respect to ground.

Parameters	Symbol	Min	Max	Units	
DC Power Supply	Core/Memory/PLL ¹	VD, VPLL	0.90	1.32	V
	I/O interface ¹	VL	1.62	3.6	V
Ambient Temperature	T_A	0	+70	°C	
Ambient Temperature	T_A	-40	+105	°C	
Junction Operating Temperature	T_J	-40	+110	°C	
External Voltage Applied to Digital Input	V_{IND}	-0.3	$V_L * 1.1$	V	

1. VL must rise before or simultaneously with VD and VPLL.

4.3 Power Supply Characteristics—1.0 V Power Dissipation

Test Conditions (unless otherwise specified): VD,VPLL=1.0 V, VL=1.8 V, GND = 0 V; all voltages with respect to GND.
T_A = +25°C.

Parameters		Typical	Units
Core and I/O Operating ¹	VD + VPLL ²	9.5	mA
	VL	0.8	mA
RESET Active ³	VD + VPLL ²	1.8	mA
	VL	1.5	μA
Hibernate Mode ⁴	VD + VPLL ²	11	μA
	VL	0.147	μA
Sleep Mode ⁵	VD + VPLL ²	45	μA
	VL	0.147	μA

1. Characterized with O/S and MP3 decode running at 80 MHz, 6 MHz CLOCK driving PLL, MCLK slave, I²S data delivery.

2. VPLL exists only on the QFN package. The WLCSP package combines VD and VPLL into a single VD pin.

3. Characterized with RESET driven low, CLOCK pin of CS48LV12/13 gated off, and all inputs to CS48LV12/13 driven to VL.

4. The low-power mode used in this example is Hibernate mode. Characterized with DSP core halted, all memory banks powered down, PLL powered down, and all internal clock domains gated off, CLOCK pin of CS48LV12/13 gated off, and all inputs to CS48LV12/13 driven to VL.

5. The low-power mode used in this example is Sleep mode. Characterized with DSP core halted, all memory banks powered up, PLL powered down, all internal clock domains gated off, CLOCK pin of CS48LV12/13 gated off, and all inputs to CS48LV12/13 driven to VL.

4.4 Power Supply Characteristics—1.2 V Power Dissipation

Test Conditions (unless otherwise specified): VD,VPLL=1.2 V, VL=1.8 V, GND = 0 V; all voltages with respect to GND.
T_A = +25°C.

Parameters		Typical	Units
Core and I/O Operating ¹	VD + VPLL ²	12.0	mA
	VL	0.8	mA
RESET Active ³	VD + VPLL ²	3.3	mA
	VL	1.5	μA
Hibernate Mode ⁴	VD + VPLL ²	17	μA
	VL	0.147	μA
Sleep Mode ⁵	VD + VPLL ²	75	μA
	VL	0.147	μA

1. Characterized with O/S and MP3 decode running at 80 MHz, 6 MHz CLOCK driving PLL, MCLK slave, I²S data delivery.

2. VPLL exists only on the QFN package. The WLCSP package combines VD and VPLL into a single VD pin.

3. Characterized with RESET driven low, CLOCK pin of CS48LV12/13 gated off, and all inputs to CS48LV12/13 driven to VL.

4. The low-power mode used in this example is Hibernate mode. Characterized with DSP core halted, all memory banks powered down, PLL powered down, and all internal clock domains gated off, CLOCK pin of CS48LV12/13 gated off, and all inputs to CS48LV12/13 driven to VL.

5. The low-power mode used in this example is Sleep mode. Characterized with DSP core halted, all memory banks powered up, PLL powered down, all internal clock domains gated off, CLOCK pin of CS48LV12/13 gated off, and all inputs to CS48LV12/13 driven to VL.

4.5 Thermal Characteristics

Parameter		Symbol	Min	Typ	Max	Units
QFN junction-to-ambient thermal impedance ^{1,2}	4-layer board	θ_{JA}	—	28	—	°C/Watt
WLCSP junction-to-ambient thermal impedance ^{1,2}	4-layer board	θ_{JA}	—	47	—	°C/Watt
QFN junction-to-ambient thermal impedance ^{1,3}	2-layer board	θ_{JA}	—	85	—	°C/Watt
WLCSP junction-to-ambient thermal impedance ^{1,3}	2-layer board	θ_{JA}	—	89	—	°C/Watt

1. To calculate the die temperature for a given power dissipation:

$$T_j = \text{Ambient temperature} + [(\text{Power Dissipation in Watts}) * \theta_{ja}]$$

2. Four-layer board is specified as a 76 mm X 114 mm, 1.6 mm thick FR-4 material with 1-oz. copper covering 20% of the top and bottom layers and 0.5-oz. copper covering 90% of the internal power plane and ground plane layer

3. Two-layer board is specified as a 76 mm X 114 mm, 1.6 mm thick FR-4 material with 1-oz. copper covering 20% of the top and bottom layers.

4.6 Digital Interface Specifications and Characteristics

Test Conditions (unless otherwise specified): VL = 1.8 V–3.3 V, VD = 1.0 V–1.2 V; GND = 0 V; T_A = +25°C.

	Parameters	Test Conditions		Symbol	Min	Typ	Max	Units
	Input leakage current ¹	—	—	I _{in}	—	—	500	nA
	Internal weak pull-up ²	—	—	—	15	—	60	kΩ
	Input capacitance ³	—	—	—	—	10	—	pF
VL logic	High-level output voltage ⁴	VL = 3.3 V	I _{OH} = 2 mA	V _{OH}	VL–0.4	—	—	V
	Low-level output voltage ⁴	VL = 3.3 V	I _{OL} = 2 mA	V _{OL}	—	—	0.20•VL	V
	High-level output voltage ⁴	VL = 1.8 V	I _{OH} = 1 mA	V _{OH}	VL–0.4	—	—	V
	Low-level output voltage ⁴	VL = 1.8 V	I _{OL} = 1 mA	V _{OL}	—	—	0.20•VL	V
	High-level input voltage	—	—	V _{IH}	0.76•VL	—	—	V
	Low-level input voltage	—	—	V _{IL}	—	—	0.30•VL	V

1. Specification is per pin, and does not include current through pull-up.

2. The effective pull-up value decreases (more current is provided) with increased VL.

3. This value is by design and not a tested parameter.

4. This value tested with 2-mA drivers enabled on pins.

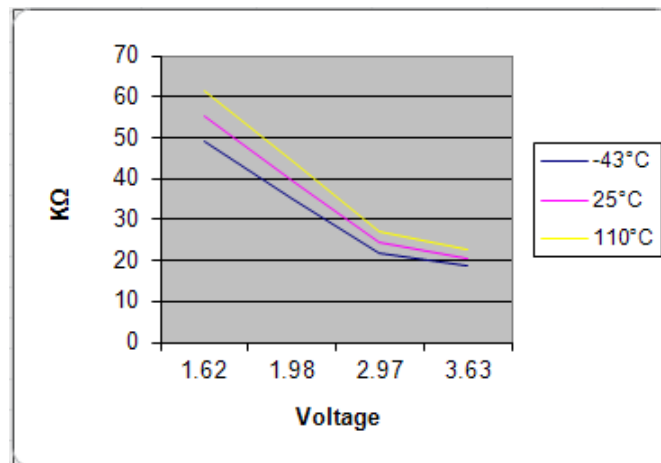

Figure 4-1. Internal Weak Pull-up

4.7 Switching Characteristics—RESET

Parameter	Symbol	Min	Max	Unit
RESET minimum pulse width low ¹	T_{rstl}	1	—	μs
All bidirectional pins high-Z after RESET low	T_{rst2z}	—	100	ns
Configuration pins setup before RESET high	T_{rstsu}	50	—	ns
Configuration pins hold after RESET high	T_{rsthd}	20	—	ns

1. The rising edge of $\overline{\text{RESET}}$ must not occur before the power supplies are stable at their recommended operating values. In addition, for the configuration pins to be read correctly, the RESET T_{rstl} requirement must be met.

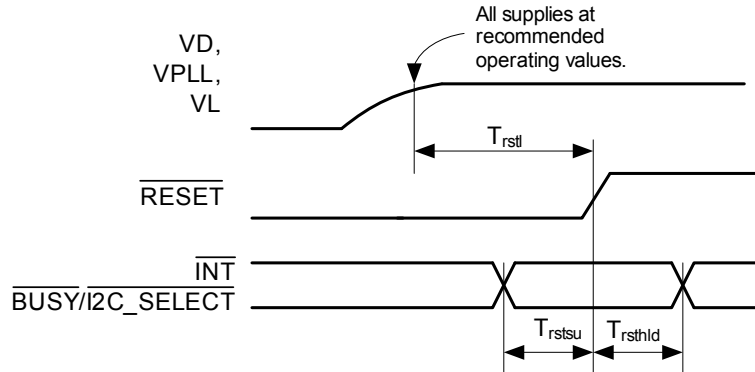

Figure 4-2. RESET Timing at Power-On

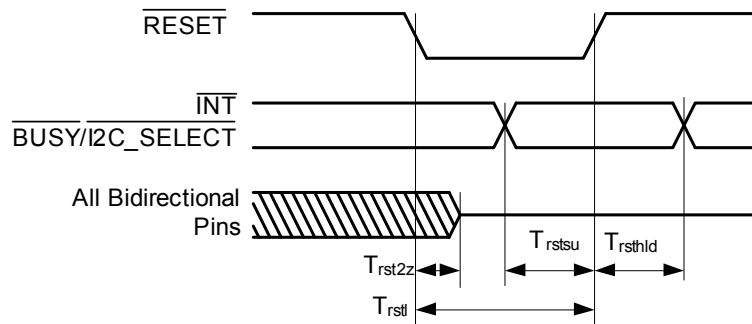

Figure 4-3. RESET Timing after Power is Stable

4.8 Switching Characteristics—CLOCK

Parameter	Symbol	Min	Max	Unit
External clock operating frequency	F_{CLOCK}	3.072	38.4	MHz
CLOCK period	T_{CLOCK}	26	325	ns
CLOCK high time	T_{CLOCKh}	$45\% \cdot T_{\text{CLOCK}}$	$55\% \cdot T_{\text{CLOCK}}$	ns
CLOCK low time	T_{CLOCKl}	$45\% \cdot T_{\text{CLOCK}}$	$55\% \cdot T_{\text{CLOCK}}$	ns

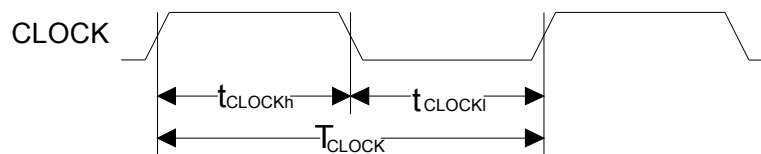

Figure 4-4. CLOCK Timing

4.9 Switching Characteristics—Internal Clock

Parameter	Symbol	Min	Typ	Max	Unit
Internal DCLK frequency ¹ (VD, VPLL = 1.2 V)	F_{dclk}	$F_{CLOCK}/256$	—	130	MHz
Internal DCLK frequency ¹ (VD, VPLL = 1.0 V)	F_{dclk}	$F_{CLOCK}/256$	—	80	MHz
Internal DCLK period (VD, VPLL = 1.2 V)	DCLKP	7.69	—	$256/F_{CLOCK}$	ns
Internal DCLK period (VD, VPLL = 1.0 V)	DCLKP	12.5	—	$256/F_{CLOCK}$	ns
Cycle-to-cycle jitter on Internal DCLK or Mastered MCLK ²	—	—	500	—	ps

1. After initial power-on reset, $F_{dclk} = F_{CLOCK}$. After initial kick-start commands, the PLL is locked to max F_{dclk} and remains locked until PLL is reconfigured for a new setting or the next \overline{RESET} pulse.

2. This parameter is characterized with a VCO speed of 330 MHz.

4.10 Switching Characteristics—Serial Control Port—SPI Slave Mode

Parameter	Symbol	Min	Typical	Max	Units
CLK frequency ¹	f_{spisck}	—	—	25	MHz
CS falling to CLK rising	t_{spicss}	24	—	—	ns
CLK low time	t_{spickl}	20	—	—	ns
CLK high time	t_{spickh}	20	—	—	ns
Setup time MOSI input	t_{spidsu}	5	—	—	ns
Hold time MOSI input	t_{spidh}	5	—	—	ns
CLK low to MISO output valid	t_{spidov}	—	—	11	ns
CLK falling to INT rising	$t_{spiirqh}$	—	—	20	ns
CS rising to INT falling	$t_{spiirql}$	0	—	—	ns
CLK low to CS rising	t_{spicsh}	24	—	—	ns
CS rising to MISO output high-Z	$t_{spicsdz}$	—	20	—	ns
CLK rising to BUSY falling	$t_{spicbsyl}$	—	$3 \cdot DCLKP + 20$	—	ns

1. The specification f_{spisck} indicates the maximum speed of the hardware. The system designer should be aware that the actual maximum speed of the communication port can be limited by the firmware application. Flow control using the BUSY pin should be implemented to prevent overflow of the input data buffer. Maximum SPI clock speed is $F_{dclk}/2$. Before locking PLL, $F_{dclk} = F_{CLOCK}$.

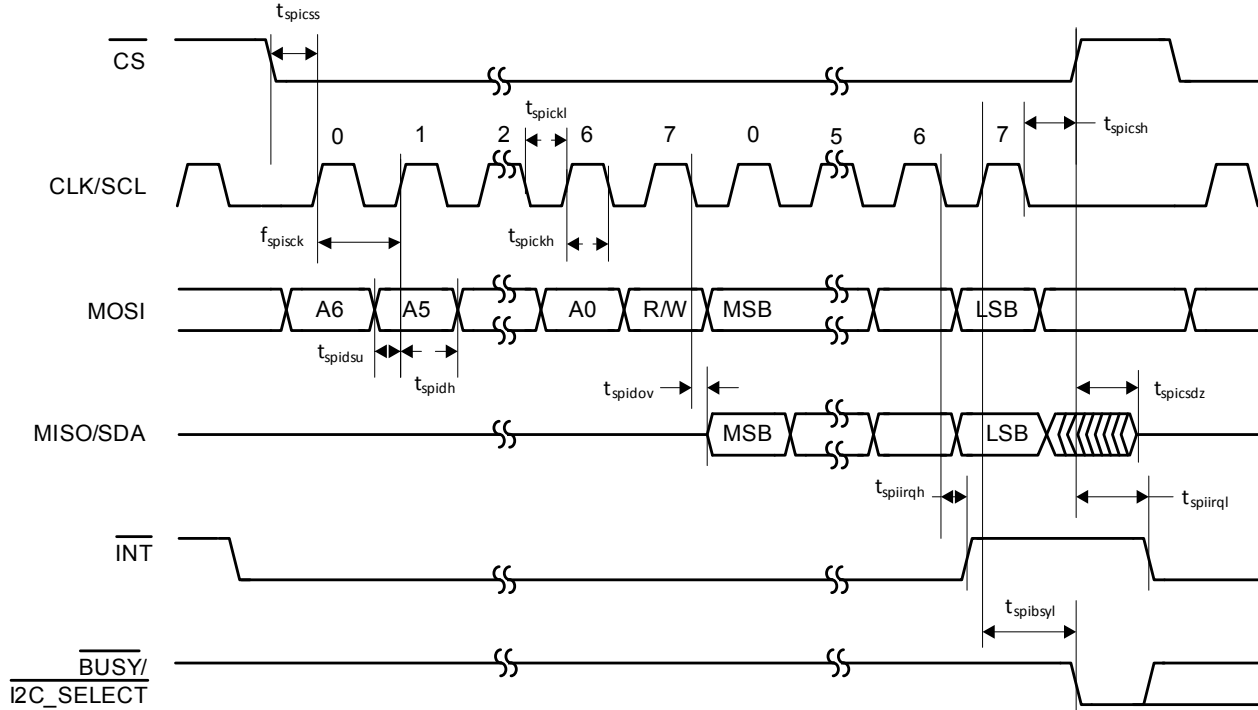

Figure 4-5. Serial Control Port—SPI Slave Mode Timing

4.11 Switching Characteristics—Serial Control Port—I2C Slave Mode

Parameter	Symbol	Min	Typical	Max	Units
SCL frequency ¹	f_{iicck}	—	—	400	kHz
SCL low time	t_{iicckl}	1.25	—	—	μ s
SCL high time	t_{iicckh}	1.25	—	—	μ s
SCL and SDA rise time	t_r	—	—	75	ns
SCL and SDA fall time	t_f	—	—	75	ns
SCL rising to SDA rising or falling for START or STOP condition	$t_{iicckcmd}$	1.25	—	—	μ s
START condition to SCL falling	$t_{iicstsc}$	1.25	—	—	μ s
SCL falling to STOP condition	t_{iicstp}	2.5	—	—	μ s
Bus free time between STOP and START conditions	t_{iicbft}	3	—	—	μ s
Setup time SDA input valid to SCL rising	t_{iicsu}	100	—	—	ns
SDA input hold time after SCL falling	t_{iich}	0	—	—	ns
SDA output hold time from SCL falling	t_{hddo}	—	—	18	ns
SCL falling to INT rising	$t_{iicirqh}$	—	—	$3 \cdot DCLKP + 40$	ns
NAK condition to INT low	$t_{iicirql}$	—	$3 \cdot DCLKP + 20$	—	ns
SCL rising to BUSY low	$t_{iicbsyl}$	—	$3 \cdot DCLKP + 20$	—	ns

1. The specification f_{iicck} indicates the maximum speed of the hardware. The system designer should be aware that the actual maximum speed of the communication port can be limited by the firmware application. Flow control using the BUSY pin should be implemented to prevent overflow of the input data buffer.

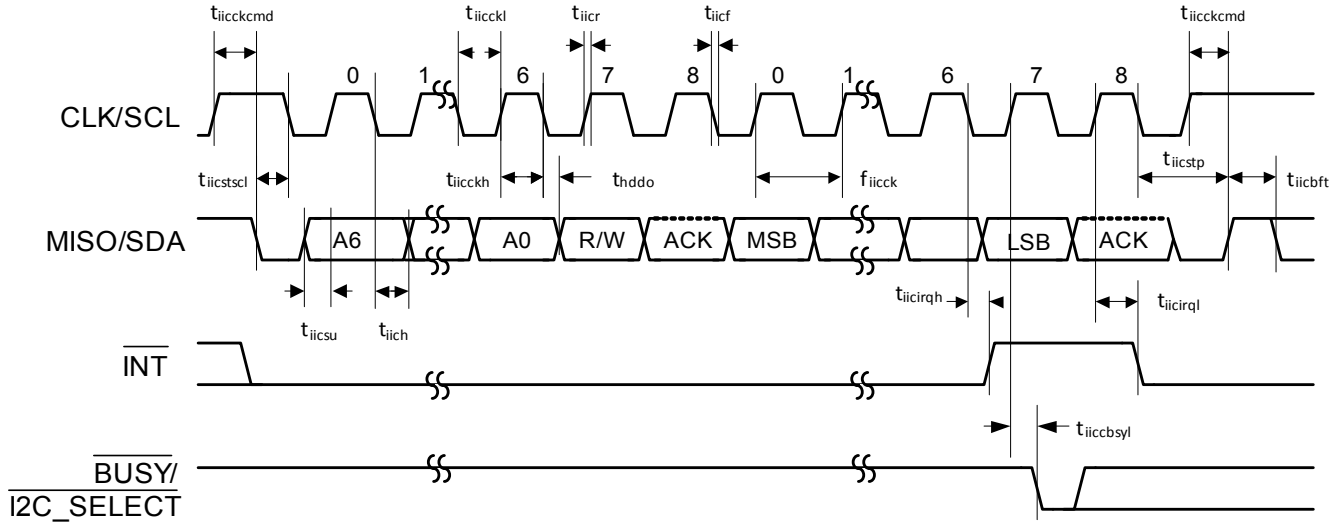

Figure 4-6. Serial Control Port—I2C Slave Mode Timing

4.12 Switching Characteristics—Digital Audio Slave Input Port

Parameter		Symbol	Min	Max	Unit
SCLK period		$T_{daiclkp}$	40	—	ns
SCLK duty cycle		—	45	55	%
Setup time DAI_Dx ¹		t_{daidsu}	10	—	ns
Hold time DAI_Dx ¹		t_{daidh}	5	—	ns
Slave mode	SCLK active edge to LRCLK transition	$t_{daisstr}$	10	—	ns
	LRCLK transition to SCLK active edge	$t_{daislrts}$	10	—	ns

1. All DAI data lines are timed relative to active edge of SCLK

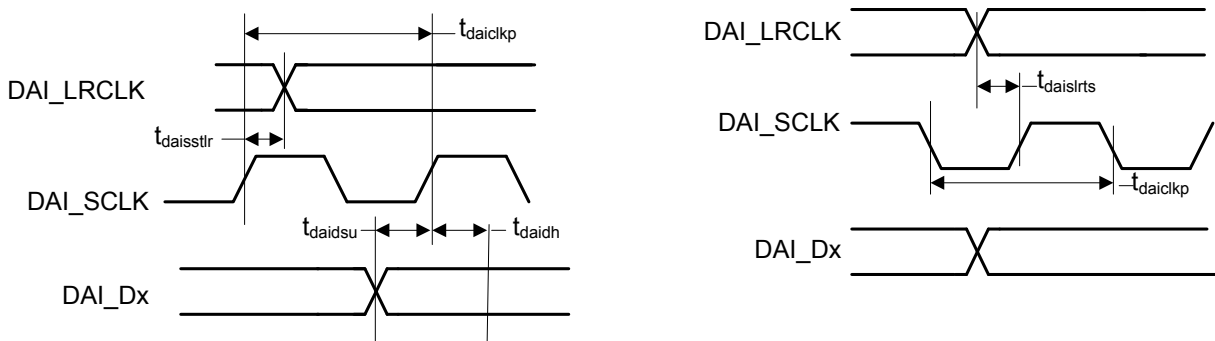
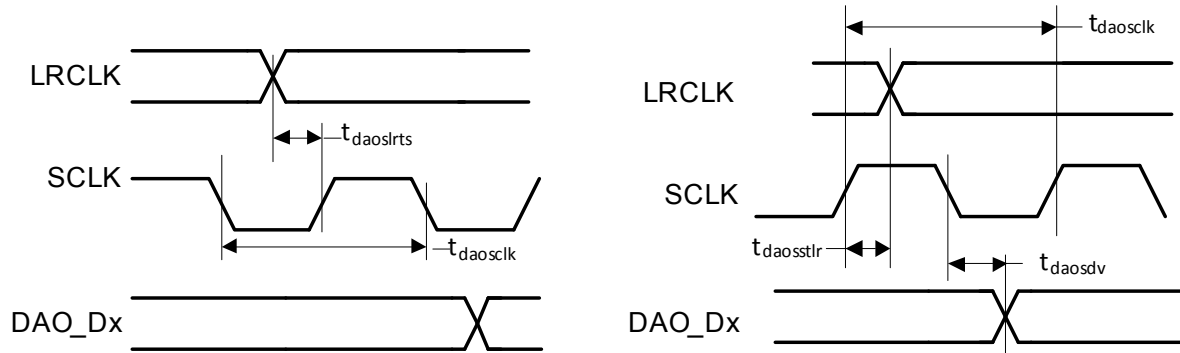

Figure 4-7. DAI Port Slave Timing Diagram

4.13 Switching Characteristics—Digital Audio Output Port

Parameter		Symbol	Min	Max	Unit
MCLK period		$T_{daomclk}$	20	—	ns
MCLK duty cycle		—	45	55	%
DAO_SCLK period for Slave mode		$T_{daosclk}$	20	—	ns
DAO_SCLK duty cycle for or Slave mode		—	40	60	%
Slave Mode	SCLK active edge to LRCLK transition	$t_{daosstr}$	10	—	ns
	LRCLK transition to SCLK active edge	$t_{daoslrs}$	10	—	ns
	DAO_Dx delay from SCLK inactive edge	t_{daosdv}	—	11	ns

Figure 4-8. Digital Audio Output (DAO) Port Timing, Slave Mode

5 Pin Descriptions

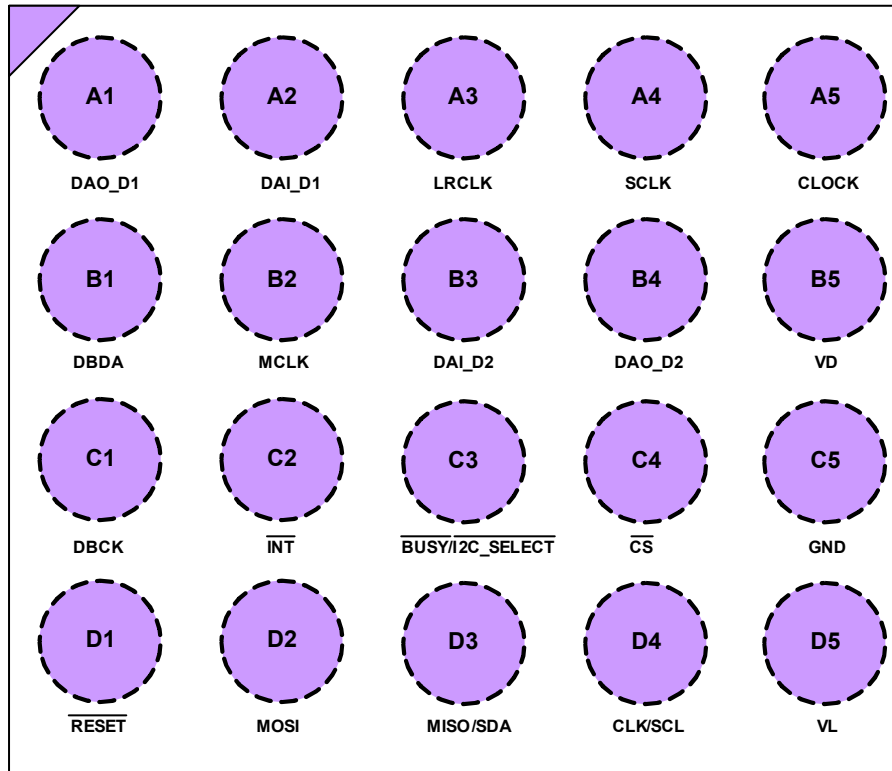

Top-Down (Through-Package) View
20-Ball WLCSP Package

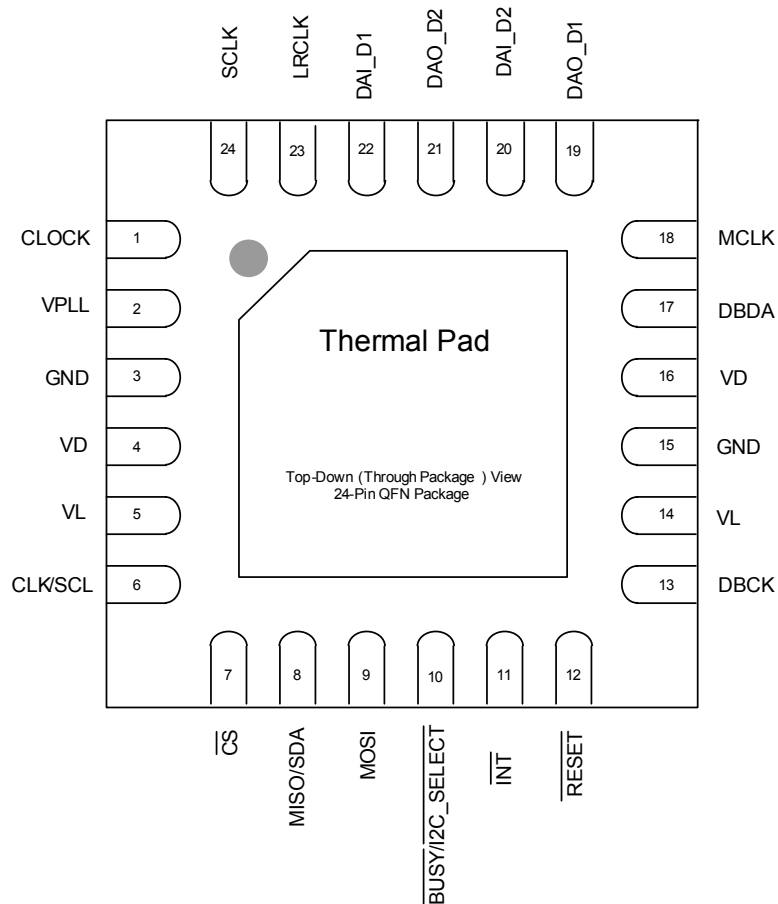

Pin Name	CSP Ball#	QFN Pin#	Pin Functions
DAO_D1	A1	19	Digital Audio Data Output 1 (Host/Tx/Uplink) • (O) DAO output 1 for two's complement serial audio data
DAI_D2	B3	20	Digital Audio Input 2 (Mic In) • (I) Two's complement serial audio data input 2 (DAI_D2)
DAO_D2	B4	21	Digital Audio Data Output 2 (Receiver/Speakers) • (O) Two's complement serial audio data output 2
DAI_D1	A2	22	Digital Audio Data Input 1 (Host/Rx/Downlink) • (I) DAI Input 1 for two's complement serial audio data
SCLK	A4	24	Digital Audio Clock • DAI serial audio bit clock
LRCLK	A3	23	Digital Audio Clock • (I/O) DAI Left/Right Clock (Frame Sync)
CLOCK	A5	1	Reference Clock Input • (I) Reference clock for internal PLL
MCLK	B2	18	Master Audio Clock • (I/O) High-speed serial audio clock (no connect for most applications)
MISO/SDA	D3	8	Serial Control Data • (O) Serial data output for SPI slave mode • (Open-Drain Bidir) Data for I ² C serial control
MOSI	D2	9	Serial Control Data • (I) Serial data input for SPI slave mode
CLK/SCL	D4	6	Serial Control Port Clock • (I) Serial control clock for SPI slave mode • (Open-Drain Bidir.) Serial control clock for I ² C slave
$\overline{\text{CS}}$	C4	7	Serial Control Port Select • (I) Chip select for SPI slave mode
DBDA	B1	17	Debug Serial Control Data • (Open-Drain Bidir) Open-drain serial data for the I ² C debug serial control port
DBCK	C1	13	Debug Serial Control Port Clock • (Open-Drain Bidir.) Open-drain serial clock for the I ² C debug serial control port
$\overline{\text{RESET}}$	D1	12	Reset • (I) Active low. Registers are reset to default settings and boot mode selected
$\overline{\text{INT}}$	C2	11	Interrupt (requires 10 KΩ external pull-up resistor) • (Open-Drain Output) Active low. Programmable interrupt output
$\overline{\text{BUSY/}}/$ $\overline{\text{I}^2\text{C_SELECT}}$	C3	10	Busy Indicator • (Open-Drain Output) Active low. DSP busy signal output • (I) Boot mode select 0 on rising edge of $\overline{\text{RESET}}$ (selects boot from I ² C rather than the default SPI)
VD	B5	4,16	Digital Core and Memory Power • (I) Power supply for the core and memory section
VPLL	—	2	PLL Power • (I) QFN package only. Power supply for PLL—tie to VD.
VL	D5/	5,14	Digital Interface Power • (I) Sets voltage reference level for serial audio interfaces and SP
GND	C5	3,15	Ground • (I) Ground reference
Thermal Pad	—		Thermal Pad (QFN package only) • (I) Thermal relief pad for optimized heat dissipation. This pad must be connected to GND.

5.1 I/O Pin Characteristics

Input and output levels and associated power supply voltage are shown in [Table 5-1](#). Logic levels should not exceed the corresponding power supply voltage. Typical hysteresis for VL inputs is 250 mV.

Table 5-1. I/O Pin Characteristics

Pin Name	I/O	Voltage Reference	Internal Termination	Driver	Receiver
DAO_D1	I/O	VL	Programmable pull-up	CMOS	CMOS, with hysteresis
DAI_D2	I/O	VL	Programmable pull-up	CMOS	CMOS, with hysteresis
DAO_D2	I/O	VL	Programmable pull-up	CMOS	CMOS, with hysteresis
DAI_D1	I/O	VL	Programmable pull-up	CMOS	CMOS, with hysteresis
SCLK	I/O	VL	Programmable pull-up	CMOS	CMOS, with hysteresis
LRCLK	I/O	VL	Programmable pull-up	CMOS	CMOS, with hysteresis
CLOCK	I	VL	—	—	CMOS, with hysteresis
MCLK	I/O	VL	Programmable pull-up	CMOS	CMOS, with hysteresis
MISO/SDA	I/O	VL	Programmable pull-up	CMOS/open drain	CMOS, with hysteresis
MOSI	I/O	VL	Programmable pull-up	CMOS	CMOS, with hysteresis
CLK/SCL	I/O	VL	Programmable pull-up	CMOS/open drain	CMOS, with hysteresis
$\overline{\text{CS}}$	I/O	VL	Programmable pull-up	CMOS	CMOS, with hysteresis
DBCK	I/O	VL	Programmable pull-up	CMOS/open drain	CMOS, with hysteresis
DBDA	I/O	VL	Programmable pull-up	CMOS/open drain	CMOS, with hysteresis
$\overline{\text{RESET}}$	I	VL	Pull-up	—	CMOS, with hysteresis
$\overline{\text{INT}}$	O	VL	Programmable pull-up	CMOS/open drain	CMOS, with hysteresis
$\overline{\text{BUSY}}$ / $\overline{\text{I2C_SELECT}}$	I/O	VL	Programmable pull-up	CMOS/open drain	CMOS, with hysteresis

Table 6-1. WLCSP Package Dimension (Cont.)

Symbol	Description	Dimensions
aaa	Package edge tolerance	0.05
bbb	Wafer flatness	0.1
ccc	Coplanarity	0.03
ddd	Ball/bump offset (package)	0.15
eee	Ball/bump offset (ball)	0.05

1. Basic spacing between centers.

7. Controlling dimensions are in millimeters.

8. Dimensioning and tolerancing per ASME Y 14.5M.

9. Dimension "b" applies to the solder sphere diameter "b" is measured at the midpoint between the package body and the seating plane.

10. Recommended reflow profile is per JEDEC/IPC J-STD-020.

24-PIN QFN (4 mm x 4 mm Body) Package Drawing

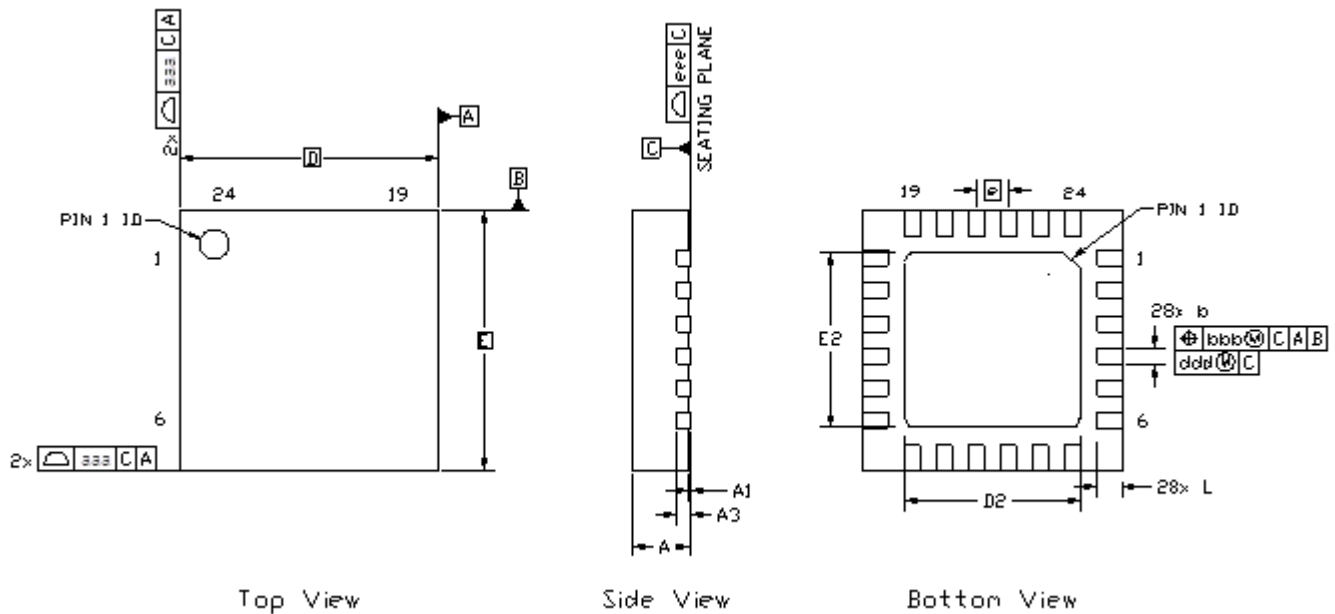
Table 6-2. QFN Package Dimension

DIM	MILLIMETERS			INCHES		
	MIN	NOM	MAX	MIN	NOM	MAX
A	0.80	0.90	1.00	0.031	0.035	0.039
A1	0.00	0.02	0.05	0.000	0.001	0.002
A3	0.20 REF			0.008 REF		
b	0.20	0.25	0.30	0.008	0.010	0.012
D	4.00 BSC			0.157 BSC		
D2	2.60	2.70	2.80	0.102	0.106	0.110
e	0.50 BSC			0.020 BSC		
E	4.00 BSC			0.157 BSC		
E2	2.60	2.70	2.80	0.102	0.106	0.110
L	0.30	0.40	0.50	0.012	0.016	0.020
aaa	0.15			0.006		
bbb	0.10			0.004		
ddd	0.05			0.002		
eee	0.08			0.003		

1. Controlling dimensions are in millimeters.
2. Dimensioning and tolerancing per ASME Y 14.5M.
3. This drawing conforms to JEDEC outline MS-012, variation VGGD-6 with exception of features D2, E2, and L, which are per supplier designation.
4. Recommended reflow profile is per JEDEC/IPC J-STD-020.

7 Ordering Information

Check with your local Cirrus Logic representative for the availability of Automotive grade packages.

Product	Description	Package	Pb-Free	Grade	Temp Range	Container	Order #
CS48LV12	Ultralow Power DSP	20 BALL WLCSP	YES	Commercial	0 °C to +70°C	Tape and Reel	CS48LV12-CWZR
		24 PIN QFN	YES	Commercial	0 °C to +70°C	Tape and Reel	CS48LV12-CNZR
		24 PIN QFN	YES	Automotive	-40°C to +105°C	Tape and Reel	CS48LV12-ENZR
CS48LV13	Ultralow Power DSP	20 BALL WLCSP	YES	Commercial	0 °C to +70°C	Tape and Reel	CS48LV13-CWZR
		24 PIN QFN	YES	Commercial	0 °C to +70°C	Tape and Reel	CS48LV13-CNZR
		24 PIN QFN	YES	Automotive	-40°C to +105°C	Tape and Reel	CS48LV13-ENZR

Reference: Philips Semiconductor, *The I²C-Bus Specification: Version 2.1*, January 2000.

8 Revision History

Revision	Date	Changes
F1	February, 2014	Initial release.

Contacting Cirrus Logic Support

For all product questions and inquiries, contact a Cirrus Logic Sales Representative.

To find the one nearest you, go to www.cirrus.com.

IMPORTANT NOTICE

Cirrus Logic, Inc. and its subsidiaries ("Cirrus") believe that the information contained in this document is accurate and reliable. However, the information is subject to change without notice and is provided "AS IS" without warranty of any kind (express or implied). Customers are advised to obtain the latest version of relevant information to verify, before placing orders, that information being relied on is current and complete. All products are sold subject to the terms and conditions of sale supplied at the time of order acknowledgment, including those pertaining to warranty, indemnification, and limitation of liability. No responsibility is assumed by Cirrus for the use of this information, including use of this information as the basis for manufacture or sale of any items, or for infringement of patents or other rights of third parties. This document is the property of Cirrus and by furnishing this information, Cirrus grants no license, express or implied under any patents, mask work rights, copyrights, trademarks, trade secrets or other intellectual property rights. Cirrus owns the copyrights associated with the information contained herein and gives consent for copies to be made of the information only for use within your organization with respect to Cirrus integrated circuits or other products of Cirrus. This consent does not extend to other copying such as copying for general distribution, advertising or promotional purposes, or for creating any work for resale.

CERTAIN APPLICATIONS USING SEMICONDUCTOR PRODUCTS MAY INVOLVE POTENTIAL RISKS OF DEATH, PERSONAL INJURY, OR SEVERE PROPERTY OR ENVIRONMENTAL DAMAGE ("CRITICAL APPLICATIONS"). CIRRUS PRODUCTS ARE NOT DESIGNED, AUTHORIZED OR WARRANTED FOR USE IN PRODUCTS SURGICALLY IMPLANTED INTO THE BODY, AUTOMOTIVE SAFETY OR SECURITY DEVICES, LIFE SUPPORT PRODUCTS OR OTHER CRITICAL APPLICATIONS. INCLUSION OF CIRRUS PRODUCTS IN SUCH APPLICATIONS IS UNDERSTOOD TO BE FULLY AT THE CUSTOMER'S RISK AND CIRRUS DISCLAIMS AND MAKES NO WARRANTY, EXPRESS, STATUTORY OR IMPLIED, INCLUDING THE IMPLIED WARRANTIES OF MERCHANTABILITY AND FITNESS FOR PARTICULAR PURPOSE, WITH REGARD TO ANY CIRRUS PRODUCT THAT IS USED IN SUCH A MANNER. IF THE CUSTOMER OR CUSTOMER'S CUSTOMER USES OR PERMITS THE USE OF CIRRUS PRODUCTS IN CRITICAL APPLICATIONS, CUSTOMER AGREES, BY SUCH USE, TO FULLY INDEMNIFY CIRRUS, ITS OFFICERS, DIRECTORS, EMPLOYEES, DISTRIBUTORS AND OTHER AGENTS FROM ANY AND ALL LIABILITY, INCLUDING ATTORNEYS' FEES AND COSTS, THAT MAY RESULT FROM OR ARISE IN CONNECTION WITH THESE USES.

Cirrus Logic, Cirrus, the Cirrus Logic logo designs, Framework, SoundClear, SoundClear Voice, InstantAdapt, ASR Enhance, RAPID2, and DSP Composer are trademarks of Cirrus Logic, Inc. and its subsidiaries. All other brand and product names in this document may be trademarks or service marks of their respective owners.

Microsoft Windows is a registered trademark of Microsoft Corporation.

SPI is a trademark of Motorola.

Dolby is a registered trademarks of Dolby Laboratories, Inc. Supply of an implementation of Dolby Technology does not convey a license nor imply a right under any patent, or any other industrial or Intellectual Property Right of Dolby Laboratories, to use the Implementation in any finished end-user or ready-to-use final product. It is hereby notified that a license for such use is required from Dolby Laboratories.

DTS is a registered trademark of the Digital Theater Systems, Inc. It is hereby notified that a third-party license from DTS is necessary to distribute software of DTS in any finished end-user or ready-to-use final product.

Sensory and TrulyHandsfree are trademarks of Sensory, Inc. It is hereby notified that a third-party license from Sensory, Inc. is required to use or distribute its technology in any finished end-user or ready-to-use final product.