

#### Features

- Two (12kHz/16kHz) SPM Detectors
- Standard 3.579545MHz Xtal
- Selectable Bandwidth Limits
- Excellent Speech-Band Rejection
- Low Power 3.0V to 5.0V Operation

#### Applications

- Pair-Gain Systems
- Out-of-Band Signaling Systems
- Call Charge Applications in PBX and PABX Line Cards

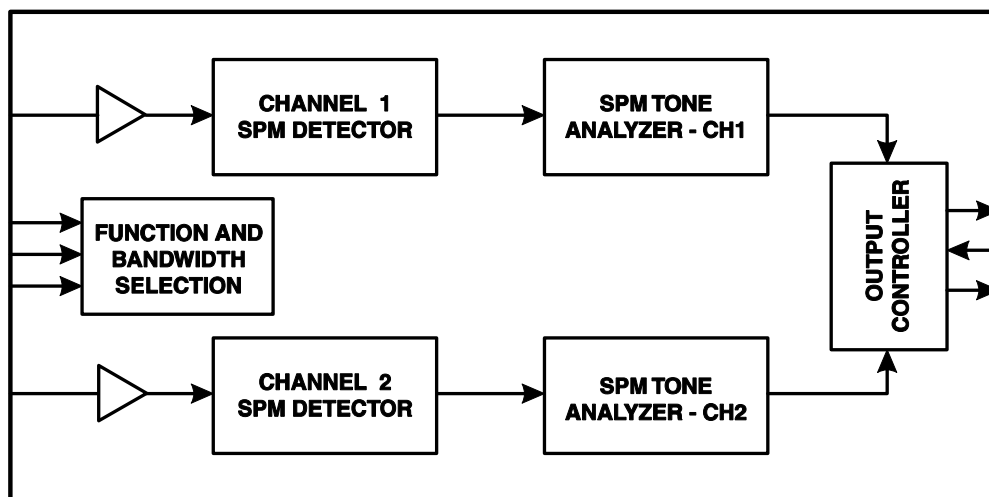

The CMX661 is a low power, Dual Subscriber Pulse Metering (SPM) Detector – *two detectors on a single chip* – to indicate the presence on a telephone line of either 12kHz or 16kHz telephone call charge frequencies. The detection frequency and bandwidth are common to both detectors and may be externally selected. The detection sensitivity is set independently for each channel by external components and the detector outputs can be set to a high impedance state for device multiplexing requirements in PBX and PABX line card applications.

Flexibility of decode bandwidth settings allows the CMX661 to operate in systems where the SPM generation is not necessarily perfectly accurate or stable. External hardwired selection of functionality economizes on the number of host  $\mu\text{C}$  I/O control lines required, while the rapid response and de-response times of the CMX661 permit flexible tone length qualification by the host  $\mu\text{C}$ .

The CMX661 offers low (3.0V) operating voltage and power, consuming  $\approx 750\mu\text{A}$  at 3V. It is available in low-cost 16-pin plastic DIL and SOIC packages.

# CONTENTS

Section	Page
<b>1. Block Diagram .....</b>	<b>3</b>
<b>2. Signal List .....</b>	<b>4</b>
<b>3. External Components .....</b>	<b>5</b>
<b>4. General Description .....</b>	<b>6</b>
4.1 Description of Blocks .....	6
4.1.1 Crystal Oscillator and Clock Dividers .....	6
4.1.2 Input Operational Amplifiers .....	6
4.1.3 SPM Tone Bandpass Filter .....	6
4.1.4 Level Detection and Pulse Generator Circuits .....	6
4.1.5 Period Measurement Logic .....	6
4.1.6 Output Enable Circuits .....	6
4.2 Operating States .....	6
4.2.1 Will Detect and Will Not Detect Bandwidths .....	7
4.2.2 System Select .....	7
<b>5. Application Notes .....</b>	<b>8</b>
5.1 Signal Input Configurations .....	8
5.2 Crystal/Clock Distribution .....	8
5.3 Channel 1 and Channel 2 Output Format .....	8
5.4 Setting Level Sensitivity via External Components .....	9
5.5 Aliasing .....	9
<b>6. Performance Specification .....</b>	<b>11</b>
6.1 Electrical Performance .....	11
6.1.1 Absolute Maximum Ratings .....	11
6.1.2 Operating Limits .....	11
6.1.3 Operating Characteristics .....	12
6.2 Packaging .....	14

Note: This product is in development: Changes and additions will be made to this specification. Items marked TBD or left blank will be included in later issues.

**Information in this data sheet should not be relied upon for final product design.**

MX-COM, Inc. reserves the right to change specifications at any time and without notice.
------------------------------------------------------------------------------------------

# 1. Block Diagram

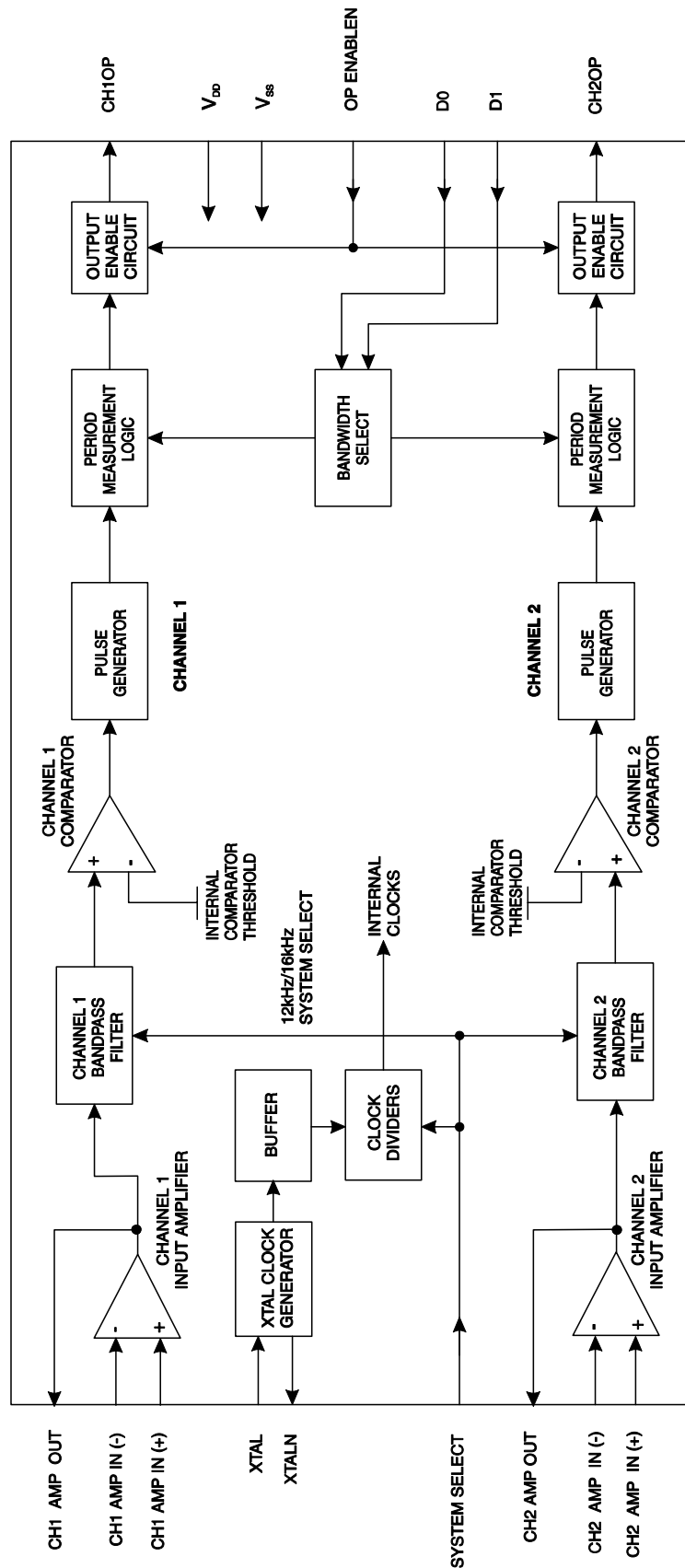

Figure 1: Block Diagram

## 2. Signal List

Packages		Signal		Description
D4 Pin No.	P3 Pin No.	Name	Type	
1	1	XTAL	Input	The input of the on-chip oscillator for use with a 3.579545MHz Xtal in conjunction with the XTALN output; circuit components are on-chip.
2	2	XTALN	Output	The inverted output of the on-chip oscillator.
3	3	CH2 OP	Output	The digital output of the Channel 2 SPM detector, when enabled. Logic '0' (low) when tone is detected.
4	4	CH1 OP	Output	The digital output of the Channel 1 SPM detector, when enabled. Logic '0' (low) when tone is detected.
5	5	CH1 AMP OUT	Output	The output of the Channel 1 input amplifier. See Figure 2 and Figure 3.
6	6	CH1 AMP IN (-)	Input	The negative input to the Channel 1 input amplifier. See Figure 2 and Figure 3.
7	7	CH1 AMP IN (+)	Input	The positive input to the Channel 1 Input amplifier. See Figure 2 and Figure 3.
8	8	V <sub>SS</sub>	Power	The negative supply rail (ground).
9	9	CH2 AMP IN (+)	Input	The positive input to the Channel 2 input amplifier. See Figure 2 and Figure 3.
10	10	CH2 AMP IN (-)	Input	The negative input to the Channel 2 input amplifier. See Figure 2 and Figure 3.
11	11	CH2 AMP OUT	Output	The output of the Channel 2 input amplifier. See Figure 2 and Figure 3.
12	12	OP ENABLEN	Input	For multi-chip output multiplexing; controls the state of both Channel 1 and Channel 2 outputs. When this input is placed high (logic '1') both outputs are set to a high impedance. When placed at logic '0' (low) both outputs are enabled.
13	13	D0	Input	The LSB of the two bits, which set the 'Will Decode' bandwidth of the CMX661.
14	14	D1	Input	The MSB of the two bits, which set the 'Will Decode' bandwidth of the CMX661.
15	15	SYSTEM SELECT	Input	Selects the system frequency. High (logic '1') = 12kHz; Low (logic '0') = 16kHz. This signal has an internal pull-up resistor, so if left unconnected the CMX661 will detect 12kHz by default.
16	16	V <sub>DD</sub>	Power	The positive supply rail. Critical levels and voltages within the CMX661 are dependent upon this supply. This pin should be decoupled to V <sub>SS</sub> by a capacitor mounted close to the device pins.

Table 1: Signal List

### 3. External Components

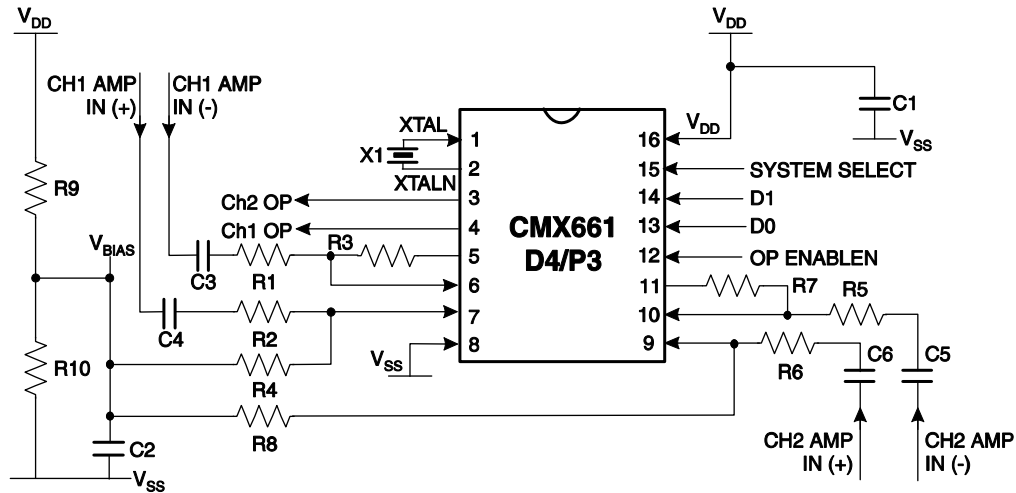

Figure 2: Typical External Components

R1	120kΩ	±1%	R7	100kΩ	±1%	C1	1.0μF	±20%
R2	120kΩ	±1%	R8	100kΩ	±1%	C2	1.0μF	±20%
R3	100kΩ	±1%	R9	15kΩ	±1%	C3	330pF	±5%
R4	100kΩ	±1%	R10	15kΩ	±1%	C4	330pF	±5%
R5	120kΩ	±1%				C5	330pF	±5%
R6	120kΩ	±1%	X1	3.579545MHz		C6	330pF	±5%

Table 2: Recommended External Components

Input amplifier components R1, C3, R2, C4, R5, C5, R6 and C6 should be chosen to set the required sensitivity of the CMX661 (see Section 5.4). Typical values only are shown above. Note that when calculating/selecting gain components, R3, R4, R7 and R8 should always be greater than or equal to 100kΩ.  $V_{BIAS}$  is not available from the CMX661 and so must be generated by an external voltage divider (R9 and R10) from  $V_{DD}$ . Particular attention should be paid to decoupling  $V_{DD}$  and keeping the power, ground and signal lines free from unnecessary noise.

Telephone systems may have unusually high dc and ac voltages present on the line, as either differential or common mode signals. If the CMX661 is part of a host system which does not have its own input protection, then protection diodes must be added to both signal inputs (+ and -) so that the voltage on any pin is limited to within  $V_{SS} - 0.3V$  and  $V_{DD} + 0.3V$ . The breakdown voltage of capacitors and the peak inverse voltage of diodes must be sufficient to withstand the sum of the dc and peak-peak ac voltages applied.

## 4. General Description

### 4.1 Description of Blocks

#### 4.1.1 Crystal Oscillator and Clock Dividers

These circuits derive the internal logic clocks, decode frequencies, and transmit frequencies by frequency division of a reference frequency that is generated by the on-chip crystal oscillator. The only external component required is a 3.579545MHz crystal, which should be connected across the XTAL and XTALN pins. All other oscillator components are on-chip.

#### 4.1.2 Input Operational Amplifiers

The input signals are applied to the CMX661 via these amplifiers, which use the external components shown in Figure 2. The external gain setting components should be calculated by the method described in Section 5.4, using the values obtained from Figure 5.

#### 4.1.3 SPM Tone Bandpass Filter

These are tone bandpass/audio reject filters automatically centered on the system frequency (12kHz or 16kHz) being detected. Their gain is constant so the internal device sensitivity is also constant.

#### 4.1.4 Level Detection and Pulse Generator Circuits

The outputs from the bandpass filters are input to these circuits that perform the signal level discrimination function for the CMX661. Signals that fulfill the system level requirements cause a stream of digital pulses, one per 32 cycles of input signal, to be generated. These pulses are sent to the period measurement circuitry.

#### 4.1.5 Period Measurement Logic

This digital circuit block inputs the stream of pulses from the level detection circuits and measures their repetition rate against a predetermined maximum and minimum. Because each pulse from the level detect circuit occurs once per 32 cycles of input signal, this has the effect of averaging the input signal period over this number of cycles. A valid SPM tone is recognized when 3 successive correctly spaced pulses are received. This causes a signal to appear immediately at the relevant channel output signifying receipt of a valid SPM signal. Depending upon the frequency, within the legal bandwidth, received, the CMX661 should respond within 10-15ms (see Section 6 and Figure 4).

#### 4.1.6 Output Enable Circuits

These enable the output logic pins 'Channel 1 Output' and 'Channel 2 Output'. These outputs can be made high impedance by setting the OP ENABLEN pin high. When enabled, a high (logic '1') indicates the tone is absent, a low (logic '0') indicates the tone is present.

### 4.2 Operating States

The CMX661 is a dual-channel SPM detector where both detectors are set to the same bandwidth and system frequency (12kHz or 16kHz). The sensitivity of each detector is set via external components. The decode bandwidths can be set to  $\pm 1.5\%$ ,  $\pm 3\%$ ,  $\pm 5\%$  and  $\pm 7.5\%$  of the nominal tone frequency by means of the D0 and D1 logic inputs and the system frequency is set by the SYSTEM SELECT logic input. Each decoder logic output has a very short response and deresponse time so that it forms an 'envelope' of the input tone. Host  $\mu\text{C}$  systems must decide whether the received signal fulfills the system tone pulse length requirements. The outputs can be set to a high impedance state for device multiplexing by use of the OP ENABLEN pin (logic '1' gives a high impedance state on the decoder outputs, logic '0' gives a normal (logic) output on these pins).

The sensitivity of each channel is set by correct selection of external components around each channel input amplifier. See Section 5.4 and Figure 5 for a method of selecting amplifier gain and components to meet a particular sensitivity requirement.

#### 4.2.1 Will Detect and Will Not Detect Bandwidths

There are four selectable bandwidths which are common to both channels. The 'will detect' bandwidth can be programmed to  $\pm 1.5\%$ ,  $\pm 3\%$ ,  $\pm 5\%$  or  $\pm 7.5\%$ . The corresponding 'will not detect' band edges are  $\pm 4\%$ ,  $\pm 5.5\%$ ,  $\pm 7.5\%$  and  $\pm 10\%$ . Pins D0 and D1 program the bandwidth selection, shared by both channels, as shown in Tables 4 and 5.

D0-D1 (both channels)	Lower Will Not Detect	Lower Will Detect	Upper Will Detect	Upper Will Not Detect
00	11.52kHz (-4.0%)	11.82kHz (-1.5%)	12.18kHz (+1.5%)	12.48kHz (+4.0%)
01	11.34kHz (-5.5%)	11.64kHz (-3.0%)	12.36kHz (+3.0%)	12.66kHz (+5.5%)
10	11.10kHz (-7.5%)	11.40kHz (-5.0%)	12.60kHz (+5.0%)	12.90kHz (+7.5%)
11	10.80kHz (-10.0%)	11.10kHz (-7.5%)	12.90kHz (+7.5%)	13.20kHz (+10.0%)

**Table 3: Setting 12kHz Will Detect/Will Not Detect Bandwidths**

D0-D1 (both channels)	Lower Will Not Detect	Lower Will Detect	Upper Will Detect	Upper Will Not Detect
00	15.36kHz (-4.0%)	15.76kHz (-1.5%)	16.24kHz (+1.5%)	16.64kHz (+4.0%)
01	15.12kHz (-5.5%)	15.52kHz (-3.0%)	16.48kHz (+3.0%)	16.88kHz (+5.5%)
10	14.80kHz (-7.5%)	15.20kHz (-5.0%)	16.80kHz (+5.0%)	17.20kHz (+7.5%)
11	14.40kHz (-10.0%)	14.80kHz (-7.5%)	17.20kHz (+7.5%)	17.60kHz (+10.0%)

**Table 4: Setting 16kHz Will Detect/Will Not Detect Bandwidths**

The CMX661 will always respond to valid inputs between the Lower 'Will Detect' and Upper 'Will Detect' frequencies inclusive. It will not respond to frequencies at or below the Lower 'Will Not Detect' or at or above the Upper 'Will Not Detect'.

#### 4.2.2 System Select

The System Select pin selects the operating frequencies of the CMX661 (logic '1' = 12kHz, logic '0' = 16kHz).

## 5. Application Notes

### 5.1 Signal Input Configurations

Figure 3 shows how the input amplifiers can be connected as differential mode or common mode amplifiers, according to the application.

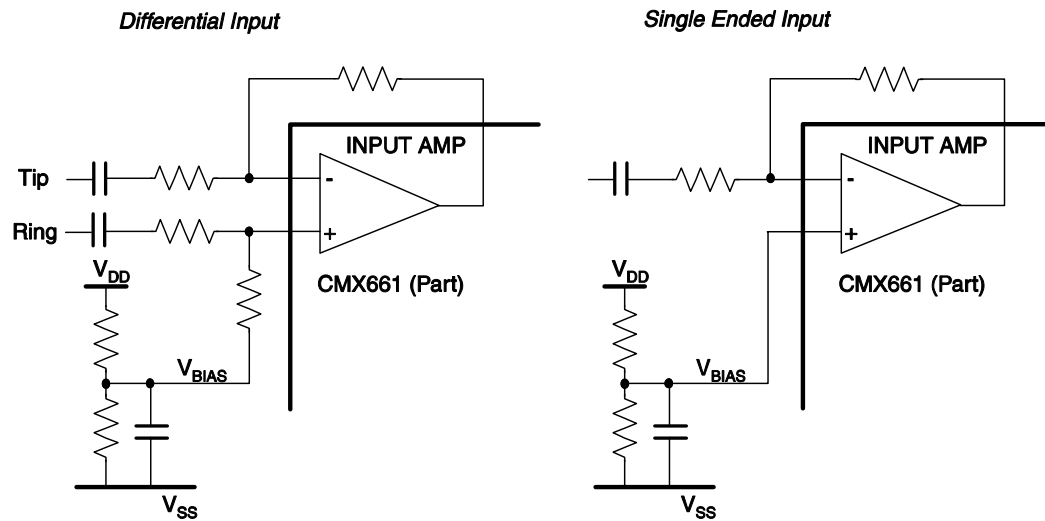

Figure 3: Example Input Configurations

External components are necessary to generate the bias voltage for the input op-amps. (The voltage labeled  $V_{BIAS}$  in Figure 3). This could be a potential divider consisting of two 15k $\Omega$  resistors and a 1.0 $\mu$ F capacitor to decouple the output.

### 5.2 Crystal/Clock Distribution

The CMX661 requires a 3.579545MHz crystal. With the exception of the crystal, all oscillator components are incorporated on chip.

### 5.3 Channel 1 and Channel 2 Output Format

Figure 4 illustrates the output format, which is the same for both channels.

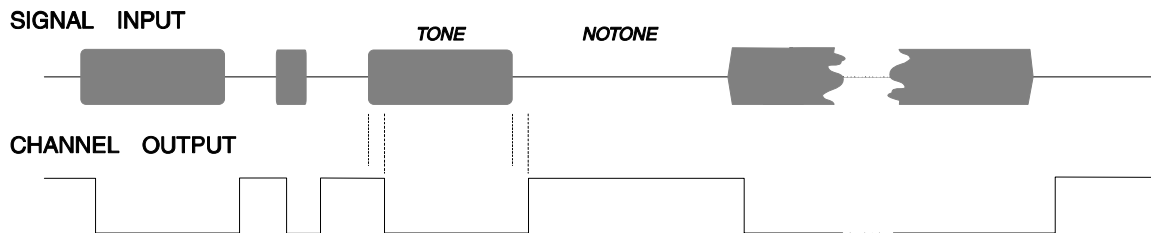

Figure 4: Detector Output Format



## 5.4 Setting Level Sensitivity via External Components

The sensitivities of the two channels are set by the correct selection of the components around the Channel Input Amplifiers.

*Input Gain Calculation:* The input amplifiers, with their external circuitry, are available to set the sensitivity of the CMX661 to conform to the user's national level specification with regard to 'Must' and 'Must-Not' decode signal levels. With reference to the graph in Figure 5, the following steps will assist in the determination of the required gain/attenuation.

### Step 1

Draw two horizontal lines from the Y-axis {Signal Level dB(ref)}

The upper line will represent the required 'Must' decode level

The lower line will represent the required 'Must-Not' decode level.

### Step 2

Mark the intersection of the upper horizontal line and the upper sloping line; drop a vertical line from this point to the X-axis {Amplifier Gain (dB)}.

The point where the vertical line meets the X-axis will indicate the MINIMUM Input gain required for reliable decoding of valid signals.

### Step 3

Mark the intersection of the lower horizontal line and the lower sloping line; drop a vertical line from this point to the X-axis.

The point where the vertical line meets the X-axis will indicate the MAXIMUM allowable Input amp gain. Input signals at or below the 'Must-Not' decode level will not be detected as long as the amplifier gain is no higher than this level.

### Step 4

Refer to the gain components shown in Figure 2. The user should calculate and select external components (R1/R3/C3, R2/R4/C4 and R5/R7/C5, R6/R8/C6) to provide amplifier gains within the limits obtained in Steps 2 and 3.

Component tolerances should not move the gain figure outside these limits. Resistors R3, R4, R7 and R8 should always be greater than or equal to 100k $\Omega$ . It is recommended that the designed gain is near the center of the calculated range.

Note that the device sensitivity is directly proportional to the applied power supply ( $V_{DD}$ ). The graph in Figure 5 is for the calculation of input gain components for the CMX661 using a  $V_{DD}$  of 5.0 ( $\pm 0.1$ ) volts.

Subtract 4.44dB from the amplifier gain for operation at 3.0V volts.

## 5.5 Aliasing

Due to the switched-capacitor filters employed in the CMX661, care should be taken to avoid any aliasing effects by removing all frequencies above 579.390kHz (16kHz mode) or 434.543kHz (12kHz mode). This can be achieved by adding bypass capacitors across R3, R4, R7 and R8, setting the -3dB breakpoint of each resistor-capacitor combination such that there is sufficient attenuation at the alias frequency and negligible effect at the desired SPM frequency.

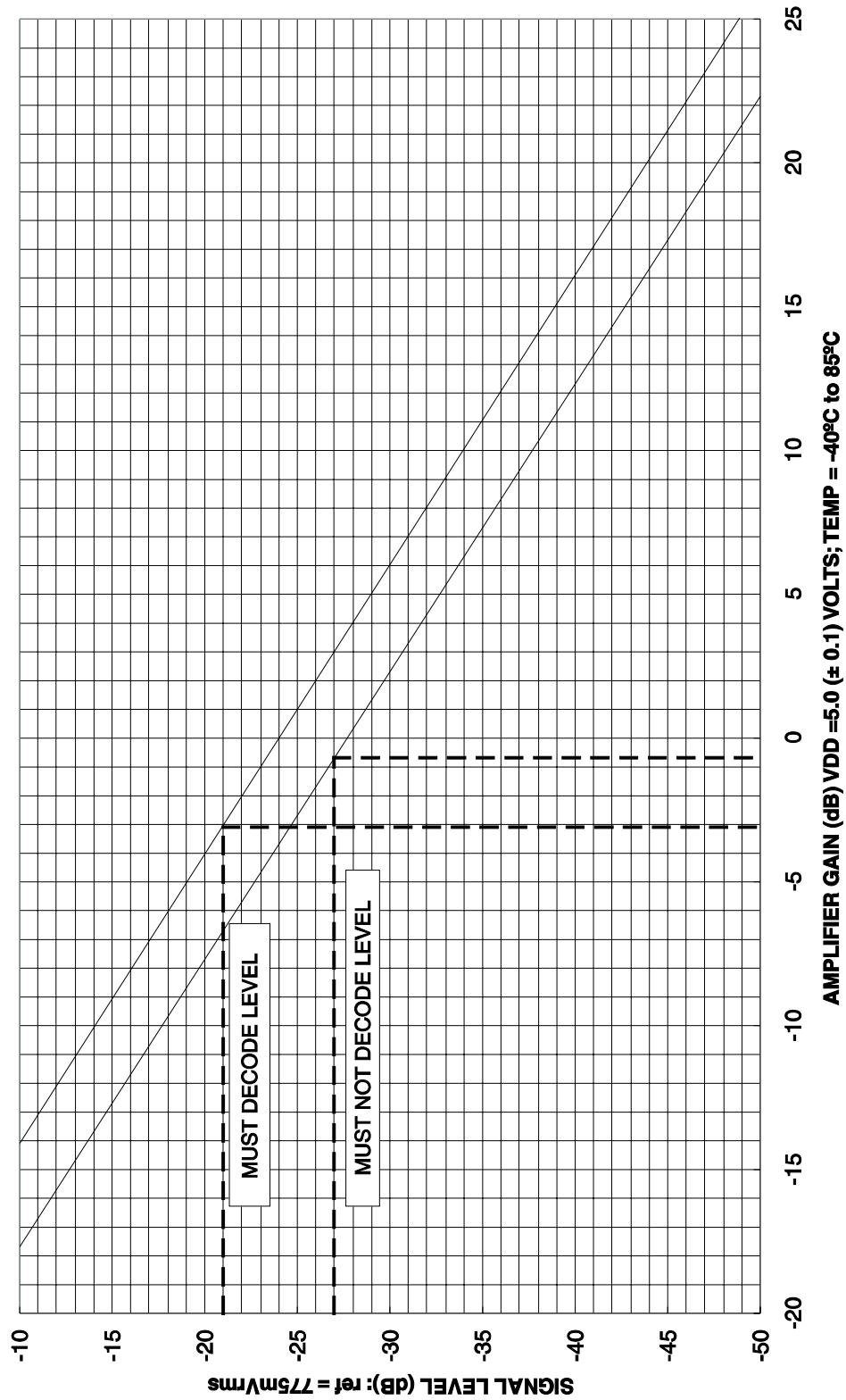

Figure 5: Input Gain Calculation Graph

## 6. Performance Specification

### 6.1 Electrical Performance

#### 6.1.1 Absolute Maximum Ratings

Exceeding these maximum ratings can result in damage to the device.

	Min.	Max.	Units
Supply ( $V_{DD} - V_{SS}$ )	-0.3	7.0	V
Voltage on any pin to $V_{SS}$	-0.3	$V_{DD} + 0.3$	V
Current into or out of $V_{DD}$ and $V_{SS}$ pins	-30	+30	mA
Current into or out of any other pin	-20	+20	mA
<b>D4/P3 Package</b>	Min.	Max.	Units
Total Allowable Power Dissipation at $T_{AMB} = 25^{\circ}\text{C}$		800	mW
Derating above $25^{\circ}\text{C}$		13	mW/ $^{\circ}\text{C}$ above $25^{\circ}\text{C}$
Storage Temperature	-55	+125	$^{\circ}\text{C}$
Operating Temperature	-40	+85	$^{\circ}\text{C}$

#### 6.1.2 Operating Limits

Correct operation of the device outside these limits is not implied.

	Notes	Min.	Max.	Units
Supply ( $V_{DD} - V_{SS}$ )		2.7	5.5	V
Operating Temperature		-40	+85	$^{\circ}\text{C}$
Xtal Frequency		3.558918	3.589368	MHz

### 6.1.3 Operating Characteristics

*Details in this section represent design target values and are not currently guaranteed.*

For the following conditions unless otherwise specified:

Xtal Frequency = 3.579545MHz, Audio Level 0dB(ref) = 775V<sub>RMS</sub>. Noise Bandwidth = 50kHz,

V<sub>DD</sub> = 3.0V to 5.5V, T<sub>AMB</sub> = -40°C to +85°C. System Setting = 12kHz or 16kHz.

	Notes	Min.	Typ.	Max.	Units
<b>DC Parameters</b>					
I <sub>DD</sub>	1	-	1.25	2.5	mA
I <sub>DD</sub>	2	-	0.75	1.5	mA
<b>Logic Inputs</b>					
Input logic "1" level		80%	-	-	V <sub>DD</sub>
Input logic "0" level		-	-	20%	V <sub>DD</sub>
Input leakage current (V <sub>IN</sub> = 0 to V <sub>DD</sub> )	3	-5.0	-	+5.0	μA
Input capacitance		-	7.5	-	pF
Input current (V <sub>IN</sub> = 0)	4	-15.0	-	-	μA
<b>Channel Outputs</b>					
Output logic "1" level (I <sub>OH</sub> = 120μA) (Enabled)		90%	-	-	V <sub>DD</sub>
Output logic "0" level (I <sub>OL</sub> = 360μA) (Enabled)		-	-	10%	V <sub>DD</sub>
Off state leakage current (High Z output)		-5.0	-	5.0	μA
Mode Change Time	5	-	-	500	ns
Response and De-Response time	6, 7, 8	-	-	15.0	ms
<b>Input Amplifiers</b>					
Input impedance (at 100Hz)		10.0	-	-	MΩ
Open Loop voltage gain (1mV <sub>RMS</sub> Input at 100Hz)		-	500	-	V/V
Common Mode range		10%	-	90%	V <sub>DD</sub>
Input signal level		-	-	100%	V <sub>DD</sub>
Output impedance (open loop)		-	6.0	-	kΩ
<b>Overall Performance</b>					
12kHz Detect Bandwidth	6, 9	11.82	-	12.18	kHz
12kHz Detect Bandwidth	6, 10	11.64	-	12.36	kHz
12kHz Detect Bandwidth	6, 11	11.40	-	12.60	kHz
12kHz Detect Bandwidth	6, 12	11.10	-	12.90	kHz
12kHz Not Detect Frequencies (below 12kHz)	6, 9	-	-	11.52	kHz
12kHz Not Detect Frequencies (below 12kHz)	6, 10	-	-	11.34	kHz
12kHz Not Detect Frequencies (below 12kHz)	6, 11	-	-	11.10	kHz
12kHz Not Detect Frequencies (below 12kHz)	6, 12	-	-	10.80	kHz
12kHz Not Detect Frequencies (above 12kHz)	6, 9	12.48	-	-	kHz
12kHz Not Detect Frequencies (above 12kHz)	6, 10	12.66	-	-	kHz
12kHz Not Detect Frequencies (above 12kHz)	6, 11	12.90	-	-	kHz
12kHz Not Detect Frequencies (above 12kHz)	6, 12	13.20	-	-	kHz

	Notes	Min.	Typ.	Max.	Units
16kHz Detect Bandwidth	6, 9	15.76	–	16.24	kHz
16kHz Detect Bandwidth	6, 10	15.52	–	16.48	kHz
16kHz Detect Bandwidth	6, 11	15.20	–	16.80	kHz
16kHz Detect Bandwidth	6, 12	14.80	–	17.20	kHz
16kHz Not-Detect Frequencies (below 16kHz)	6, 9	–	–	15.36	kHz
16kHz Not-Detect Frequencies (below 16kHz)	6, 10	–	–	15.12	kHz
16kHz Not-Detect Frequencies (below 16kHz)	6, 11	–	–	14.80	kHz
16kHz Not Detect Frequencies (below 16kHz)	6, 12	–	–	14.40	kHz
16kHz Not-Detect Frequencies (above 16kHz)	6, 9	16.64	–	–	kHz
16kHz Not-Detect Frequencies (above 16kHz)	6, 10	16.88	–	–	kHz
16kHz Not-Detect Frequencies (above 16kHz)	6, 11	17.20	–	–	kHz
16kHz Not-Detect Frequencies (above 16kHz)	6, 12	17.60	–	–	kHz
<b>Level Sensitivity</b>					
Level Sensitivity is set by external components (see Figure 2)	1, 6, 7, 13	-24.4	-26.4	-27.4	dB
<b>Signal Quality Requirements for Correct Operation</b> (see Figure 2)					
Signal to Noise Ratio (Amp input)	7, 14, 15, 16	22.0	20.0	–	dB
Signal to Voice Ratio (Amp input)	7, 14, 15, 17	-36.0	-40.0	–	dB
Signal to Voice Ratio (Amp output)	7, 14, 16, 17	-25.0	-27.0	-29.0	dB

**Notes:**

- At 5.0V. Not including any current drawn from the pins by external circuitry.
- At 3.0V. Not including any current drawn from the pins by external circuitry.
- Logic pins with no internal pull-up or pull-down resistors: OP ENABLEN, D0 and D1.
- Logic pins with an internal pull-up or pull-down resistor: SYSTEM SELECT.
- Time taken to change between high impedance and operating modes, with a maximum capacitive load of 30pF on an output.
- With adherence to Signal to Voice and Signal to Noise specifications.
- 12kHz and/or 16kHz system.
- The time delay after device powerup, change of bandwidth setting or change in input signal conditions, before the condition of the outputs can be guaranteed correct.
- With 'Will Detect' bandwidth set to  $\pm 1.5\%$ .
- With 'Will Detect' bandwidth set to  $\pm 3.0\%$ .
- With 'Will Detect' bandwidth set to  $\pm 5.0\%$ .
- With 'Will Detect' bandwidth set to  $\pm 7.5\%$ .
- With input amplifier gain setting of 0dB via external components and measured at amplifier output with  $V_{DD} = 5.0V$ . Signal sensitivity is proportional to  $V_{DD}$ .
- For immunity to false responses and/or deresponses.
- Common mode SPM and balanced voice signal.
- With balanced SPM and voice signals. To avoid false deresponses due to saturation, the peak to peak voice + noise level at the output of the input amplifier should be no greater than the dynamic range of the device.
- Maximum voice frequencies = 3.4kHz.

6.2 Packaging

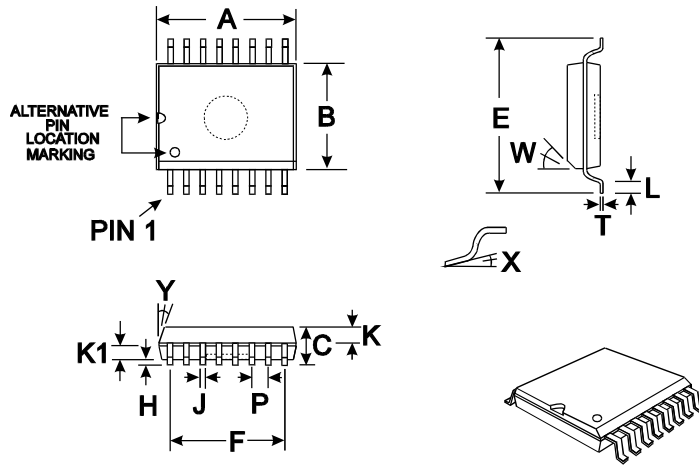

DIM.	MIN.	TYP.	MAX.
* A	0.395 (10.03)	0.413 (10.49)	
* B	0.286 (7.26)	0.299 (7.59)	
C	0.093 (2.36)	0.105 (2.67)	
E	0.390 (9.90)	0.419 (10.64)	
F		0.350 (8.89)	
H	0.003 (0.08)	0.020 (0.51)	
J	0.013 (0.33)	0.020 (0.51)	
K		0.041 (1.04)	
K1		0.041 (1.04)	
L	0.016 (0.41)	0.050 (1.27)	
P		0.050 (1.27)	
T	0.009 (0.23)	0.0125 (0.32)	
W		45°	
X	0°		10°
Y		7°	

NOTE :

\* A & B are reference datum's and do not include mold deflash or protrusions.

All dimensions in inches (mm.)  
Angles are in degrees

Figure 6: D4 Mechanical Outline: Order as part no. CMX661D4

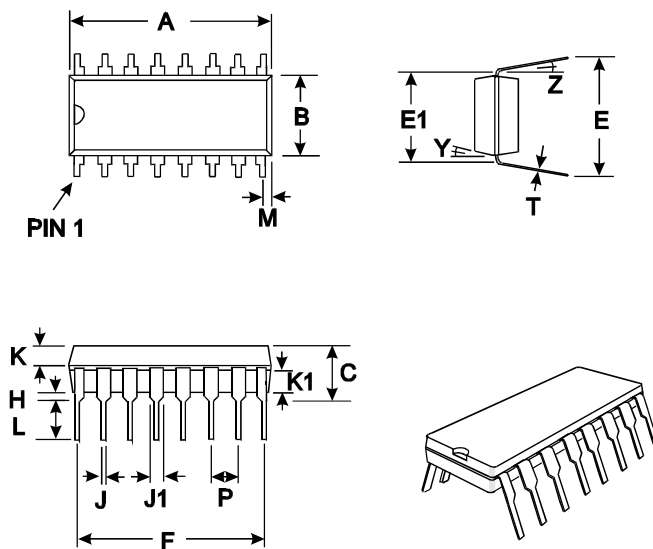

DIM.	MIN.	TYP.	MAX.
* A	0.740 (18.80)	0.810 (20.57)	
* B	0.240 (6.10)	0.262 (6.65)	
C	0.135 (3.43)	0.200 (5.08)	
E	0.300 (7.62)	0.390 (9.91)	
E1	0.290 (7.37)	0.325 (8.26)	
F		0.70 (17.78)	
H	0.015 (0.38)	0.040 (1.02)	
J	0.015 (0.38)	0.023 (0.58)	
J1	0.040 (1.02)	0.065 (1.65)	
K	0.056 (1.42)	0.064 (1.63)	
K1	0.056 (1.42)	0.064 (1.63)	
L	0.121 (3.07)	0.150 (3.81)	
M		0.028 (0.71)	
P		0.100 (2.54)	
T	0.008 (0.20)	0.015 (0.38)	
Y		7°	
Z		5°	

NOTE :

\* A & B are reference datum's and do not include mold deflash or protrusions.

All dimensions in inches (mm.)  
Angles are in degrees

Figure 7: P3 Mechanical Outline: Order as part no. CMX661P3