

Trench Gate Design Single IGBTMOD™ 600 Amperes/1200 Volts

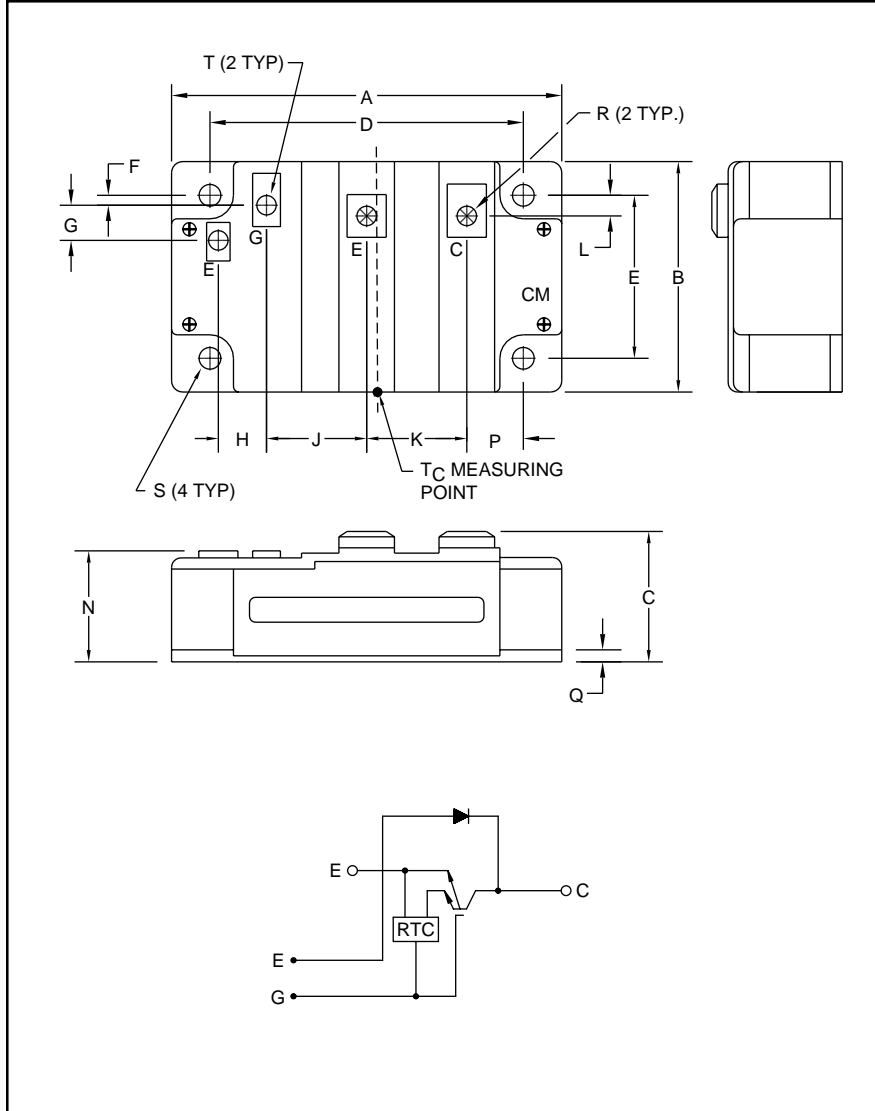

Outline Drawing and Circuit Diagram

| Dimensions | Inches | Millimeters |
|------------|------------------|----------------|
| A | 4.33 | 110.0 |
| B | 3.15 | 80.0 |
| C | 1.34 +0.04/-0.02 | 34.0 +1.0/-0.5 |
| D | 3.66±0.01 | 93.0±0.25 |
| E | 2.44±0.01 | 62.0±0.25 |
| F | 0.22 | 5.5 |
| G | 0.57 | 14.5 |
| H | 0.53 | 13.5 |
| J | 0.96 | 24.5 |

| Dimensions | Inches | Millimeters |
|------------|------------------|----------------|
| K | 1.14 | 29.0 |
| L | 0.37 | 9.5 |
| N | 1.02 +0.04/-0.02 | 26.0 +1.0/-0.5 |
| P | 0.85 | 21.5 |
| Q | 0.16 | 4.0 |
| R | M8 | M8 |
| S | 0.26 Dia. | 6.5 Dia. |
| T | M4 | M4 |



Description:

Powerex IGBTMOD™ Modules are designed for use in switching applications. Each module consists of one IGBT Transistor in a single configuration with a reverse-connected super-fast recovery free-wheel diode. All components and interconnects are isolated from the heat sinking baseplate, offering simplified system assembly and thermal management.

Features:

- Low Drive Power
- Low $V_{CE(sat)}$
- Discrete Super-Fast Recovery Free-Wheel Diode
- Isolated Baseplate for Easy Heat Sinking

Applications:

- AC Motor Control
- UPS
- Battery Powered Supplies

Ordering Information:

Example: Select the complete module number you desire from the table - i.e. CM600HU-24F is a 1200V (V_{CES}), 600 Ampere Single IGBTMOD™ Power Module.

| Type | Current Rating Amperes | V_{CES} Volts (x 50) |
|------|------------------------|------------------------|
| CM | 600 | 24 |



Powerex, Inc., 200 Hillis Street, Youngwood, Pennsylvania 15697-1800 (724) 925-7272

CM600HU-24F

Trench Gate Design Single IGBTMOD™

600 Amperes/1200 Volts

Absolute Maximum Ratings, $T_j = 25^\circ\text{C}$ unless otherwise specified

| Ratings | Symbol | CM600HU-24F | Units |
|--|------------------|-------------|------------------|
| Junction Temperature | T_j | -40 to 150 | $^\circ\text{C}$ |
| Storage Temperature | T_{stg} | -40 to 125 | $^\circ\text{C}$ |
| Collector-Emitter Voltage (G-E SHORT) | V_{CES} | 1200 | Volts |
| Gate-Emitter Voltage (C-E SHORT) | V_{GES} | ± 20 | Volts |
| Collector Current ($T_c = 25^\circ\text{C}$) | I_C | 600 | Amperes |
| Peak Collector Current ($T_j \leq 150^\circ\text{C}$) | I_{CM} | 1200* | Amperes |
| Emitter Current** ($T_c = 25^\circ\text{C}$) | I_E | 600 | Amperes |
| Peak Emitter Current** | I_{EM} | 1200* | Amperes |
| Maximum Collector Dissipation ($T_c = 25^\circ\text{C}$) | P_c | 1900 | Watts |
| Mounting Torque, M8 Main Terminal | – | 95 | in-lb |
| Mounting Torque, M6 Mounting | – | 40 | in-lb |
| Mounting Torque, M4 Terminal | – | 15 | in-lb |
| Weight | – | 600 | Grams |
| Isolation Voltage (Main Terminal to Baseplate, AC 1 min.) | V_{iso} | 2500 | Volts |

Static Electrical Characteristics, $T_j = 25^\circ\text{C}$ unless otherwise specified

| Characteristics | Symbol | Test Conditions | Min. | Typ. | Max. | Units |
|--------------------------------------|----------------------|--|------|------|------|---------------|
| Collector-Cutoff Current | I_{CES} | $V_{\text{CE}} = V_{\text{CES}}, V_{\text{GE}} = 0\text{V}$ | – | – | 2 | mA |
| Gate Leakage Voltage | I_{GES} | $V_{\text{GE}} = V_{\text{CES}}, V_{\text{CE}} = 0\text{V}$ | – | – | 80 | μA |
| Gate-Emitter Threshold Voltage | $V_{\text{GE(th)}}$ | $I_C = 60\text{mA}, V_{\text{CE}} = 10\text{V}$ | 5 | 6 | 7 | Volts |
| Collector-Emitter Saturation Voltage | $V_{\text{CE(sat)}}$ | $I_C = 600\text{A}, V_{\text{GE}} = 15\text{V}, T_j = 25^\circ\text{C}$ | – | 1.8 | 2.4 | Volts |
| | | $I_C = 600\text{A}, V_{\text{GE}} = 15\text{V}, T_j = 125^\circ\text{C}$ | – | 1.9 | – | Volts |
| Total Gate Charge | Q_G | $V_{\text{CC}} = 600\text{V}, I_C = 600\text{A}, V_{\text{GE}} = 15\text{V}$ | – | 6600 | – | nC |
| Emitter-Collector Voltage** | V_{EC} | $I_E = 600\text{A}, V_{\text{GE}} = 0\text{V}$ | – | – | 3.2 | Volts |

* Pulse width and repetition rate should be such that the device junction temperature (T_j) does not exceed $T_{j(\text{max})}$ rating.

** Represents characteristics of the anti-parallel, emitter-to-collector free-wheel diode (FWDi).

CM600HU-24F
Trench Gate Design Single IGBTMOD™
 600 Amperes/1200 Volts

Dynamic Electrical Characteristics, $T_j = 25\text{ }^\circ\text{C}$ unless otherwise specified

| Characteristics | Symbol | Test Conditions | Min. | Typ. | Max. | Units | |
|---------------------------------|---------------------|-----------------------------|------------------------------|------|------|-------|---------------|
| Input Capacitance | C_{ies} | | – | – | 230 | nf | |
| Output Capacitance | C_{oes} | $V_{CE} = 10V, V_{GE} = 0V$ | – | – | 10 | nf | |
| Reverse Transfer Capacitance | C_{res} | | – | – | 6 | nf | |
| Inductive | Turn-on Delay Time | $t_{d(on)}$ | $V_{CC} = 600V, I_C = 600A,$ | – | – | 300 | ns |
| Load | Rise Time | t_r | $V_{GE1} = V_{GE2} = 15V,$ | – | – | 150 | ns |
| Switch | Turn-off Delay Time | $t_{d(off)}$ | $R_G = 1.0\ \Omega,$ | – | – | 800 | ns |
| Times | Fall Time | t_f | Inductive Load | – | – | 300 | ns |
| Diode Reverse Recovery Time** | t_{rr} | Switching Operation | | – | – | 500 | ns |
| Diode Reverse Recovery Charge** | Q_{rr} | $I_E = 600A$ | | – | 43.2 | – | μC |

Thermal and Mechanical Characteristics, $T_j = 25\text{ }^\circ\text{C}$ unless otherwise specified

| Characteristics | Symbol | Test Conditions | Min. | Typ. | Max. | Units |
|--------------------------------------|-----------------|---|------|-------|-------|--------------------|
| Thermal Resistance, Junction to Case | $R_{th(j-c)Q}$ | Per IGBT, T_C Reference Point per Outline Drawing | – | | 0.063 | $^\circ\text{C/W}$ |
| Thermal Resistance, Junction to Case | $R_{th(j-c)D}$ | Per FWDi, T_C Reference Point per Outline Drawing | – | – | 0.075 | $^\circ\text{C/W}$ |
| Thermal Resistance, Junction to Case | $R_{th(j-c)'Q}$ | Per IGBT, T_C Reference Point Under Chip | – | 0.03 | | $^\circ\text{C/W}$ |
| Contact Thermal Resistance | $R_{th(c-f)}$ | Per Module, Thermal Grease Applied | – | 0.015 | – | $^\circ\text{C/W}$ |

** Represents characteristics of the anti-parallel, emitter-to-collector free-wheel diode (FWDi).

CM600HU-24F
Trench Gate Design Single IGBTMOD™
 600 Amperes/1200 Volts

