

Dual IGBTMOD™ F-Series Module 600 Amperes/1200 Volts

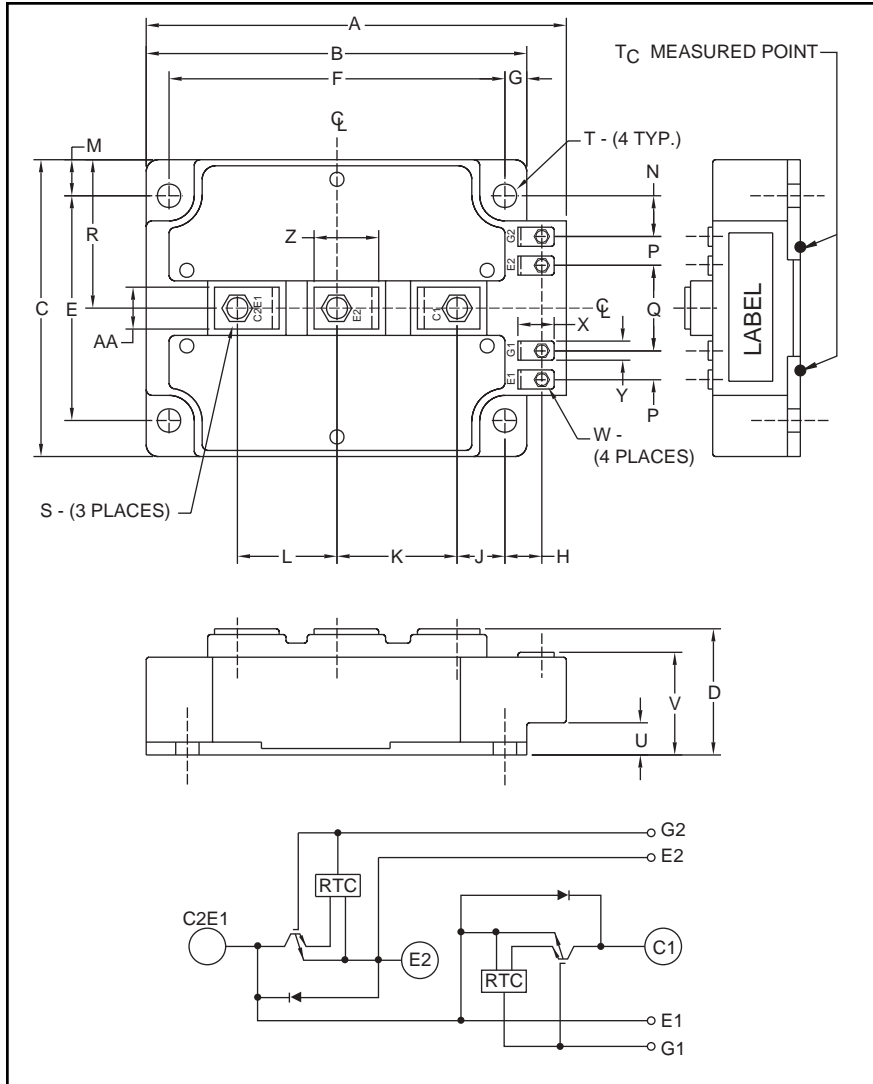

Outline Drawing and Circuit Diagram

Dimensions	Inches	Millimeters
A	5.51	140.0
B	5.12	130.0
C	5.12	130.0
D	1.38 +0/-0.02	35.0 +0/-0.5
E	4.33±0.01	110.0±0.25
F	4.33±0.01	110.0±0.25
G	0.39	10.0
H	0.45	11.5
J	0.54	13.8
K	1.72	43.8
L	1.42	36.0
M	0.39	10.0
N	0.80	20.4

Dimensions	Inches	Millimeters
P	0.57	14.5
Q	1.57	40.0
R	2.56	65.0
S	M8	M8
T	0.26 Dia.	6.5 Dia.
U	0.32	8.0
V	0.97 +0.04/-0.02	24.5 +1.0/-0.5
W	M4	M4
X	0.59	15.0
Y	0.35	9.0
Z	1.02	26.0
AA	0.79	20.0



Description:

Powerex IGBTMOD™ Modules are designed for use in switching applications. Each module consists of two IGBT Transistors in a half-bridge configuration with each transistor having a reverse-connected super-fast recovery free-wheel diode. All components and interconnects are isolated from the heat sinking baseplate, offering simplified system assembly and thermal management.

Features:

- Low Drive Power
- Low $V_{CE(sat)}$
- Discrete Super-Fast Recovery Free-Wheel Diode
- Isolated Baseplate for Easy Heat Sinking

Applications:

- AC Motor Control
- Motion/Servo Control
- UPS
- Welding Power Supplies
- Laser Power Supplies

Ordering Information:

Example: Select the complete module number you desire from the table - i.e. CM600DU-24F is a 1200V (V_{CES}), 600 Ampere Dual IGBTMOD™ Power Module.

Type	Current Rating Amperes	V_{CES} Volts (x 50)
CM	600	24



Powerex, Inc., 200 E. Hillis Street, Youngwood, Pennsylvania 15697-1800 (724) 925-7272

CM600DU-24F
Dual IGBTMOD™ F-Series Module
 600 Amperes/1200 Volts

Absolute Maximum Ratings, $T_j = 25\text{ }^\circ\text{C}$ unless otherwise specified

Ratings	Symbol	CM600DU-24F	Units
Junction Temperature	T_j	-40 to 150	$^\circ\text{C}$
Storage Temperature	T_{stg}	-40 to 125	$^\circ\text{C}$
Collector-Emitter Voltage (G-E SHORT)	V_{CES}	1200	Volts
Gate-Emitter Voltage (C-E SHORT)	V_{GES}	± 20	Volts
Collector Current ($T_c = 25^\circ\text{C}$)	I_C	600	Amperes
Peak Collector Current	I_{CM}	1200*	Amperes
Emitter Current** ($T_c = 25^\circ\text{C}$)	I_E	600	Amperes
Peak Emitter Current**	I_{EM}	1200*	Amperes
Maximum Collector Dissipation ($T_c = 25^\circ\text{C}$, $T_j \leq 150^\circ\text{C}$)	P_C	1540	Watts
Mounting Torque, M8 Main Terminal	–	95	in-lb
Mounting Torque, M6 Mounting	–	40	in-lb
G(E) Terminal, M4	–	15	in-lb
Weight	–	1200	Grams
Isolation Voltage (Main Terminal to Baseplate, AC 1 min.)	V_{iso}	2500	Volts

Static Electrical Characteristics, $T_j = 25\text{ }^\circ\text{C}$ unless otherwise specified

Characteristics	Symbol	Test Conditions	Min.	Typ.	Max.	Units
Collector-Cutoff Current	I_{CES}	$V_{CE} = V_{CES}$, $V_{GE} = 0V$	–	–	2	mA
Gate Leakage Current	I_{GES}	$V_{GE} = V_{GES}$, $V_{CE} = 0V$	–	–	80	μA
Gate-Emitter Threshold Voltage	$V_{GE(th)}$	$I_C = 60\text{mA}$, $V_{CE} = 10V$	5.0	6	7.0	Volts
Collector-Emitter Saturation Voltage	$V_{CE(sat)}$	$I_C = 600\text{A}$, $V_{GE} = 15V$, $T_j = 25^\circ\text{C}$	–	1.95	2.55	Volts
		$I_C = 600\text{A}$, $V_{GE} = 15V$, $T_j = 125^\circ\text{C}$	–	2.05	–	Volts
Total Gate Charge	Q_G	$V_{CC} = 600V$, $I_C = 600\text{A}$, $V_{GE} = 15V$	–	6600	–	nC
Emitter-Collector Voltage**	V_{EC}	$I_E = 600\text{A}$, $V_{GE} = 0V$	–	–	3.35	Volts

* Pulse width and repetition rate should be such that the device junction temperature (T_j) does not exceed $T_{j(max)}$ rating.

**Represents characteristics of the anti-parallel, emitter-to-collector free-wheel diode (FWDI).



Powerex, Inc., 200 E. Hillis Street, Youngwood, Pennsylvania 15697-1800 (724) 925-7272

CM600DU-24F
Dual IGBTMOD™ F-Series Module
 600 Amperes/1200 Volts

Dynamic Electrical Characteristics, $T_j = 25\text{ }^\circ\text{C}$ unless otherwise specified

Characteristics	Symbol	Test Conditions	Min.	Typ.	Max.	Units
Input Capacitance	C_{ies}		–	–	230	nf
Output Capacitance	C_{oes}	$V_{CE} = 10V, V_{GE} = 0V$	–	–	10	nf
Reverse Transfer Capacitance	C_{res}		–	–	6	nf
Resistive	Turn-on Delay Time	$V_{CC} = 600V, I_C = 600A,$ $V_{GE1} = V_{GE2} = 15V,$ $R_G = 1.0\Omega,$	–	–	450	ns
Load	Rise Time		$t_{d(on)}$	t_r	200	ns
Switch	Turn-off Delay Time	Inductive Load	–	–	800	ns
Times	Fall Time		$t_{d(off)}$	t_f	300	ns
Diode Reverse Recovery Time*	t_{rr}	Switching Operation	–	–	500	ns
Diode Reverse Recovery Charge*	Q_{rr}	$I_E = 600A$	–	43.2	–	μC

Thermal and Mechanical Characteristics, $T_j = 25\text{ }^\circ\text{C}$ unless otherwise specified

Characteristics	Symbol	Test Conditions	Min.	Typ.	Max.	Units
Thermal Resistance, Junction to Case	$R_{th(j-c)Q}$	Per IGBT 1/2 Module, T_c Reference Point per Outline Drawing	–	–	0.081	$^\circ C/W$
Thermal Resistance, Junction to Case	$R_{th(j-c)R}$	Per FWDi 1/2 Module, T_c Reference Point per Outline Drawing	–	–	0.11	$^\circ C/W$
Thermal Resistance	$R_{th(j-c)Q}$	Per IGBT 1/2 Module T_c Reference Point Under Chips	–	–	0.032**	$^\circ C/W$
Contact Thermal Resistance	$R_{th(c-f)}$	Per Module, Thermal Grease Applied	–	0.010	–	$^\circ C/W$
External Gate Resistance	R_G		1.0	–	52	Ω

*Represents characteristics of the anti-parallel, emitter-to-collector free-wheel diode (FWDi).

**If you use this value, $R_{th(f-a)}$ should be measured just under the chips.



Powerex, Inc., 200 E. Hillis Street, Youngwood, Pennsylvania 15697-1800 (724) 925-7272

CM600DU-24F
Dual IGBTMOD™ F-Series Module
 600 Amperes/1200 Volts

