

**Chopper HVIGBT
 Module**
 1200 Amperes/1700 Volts

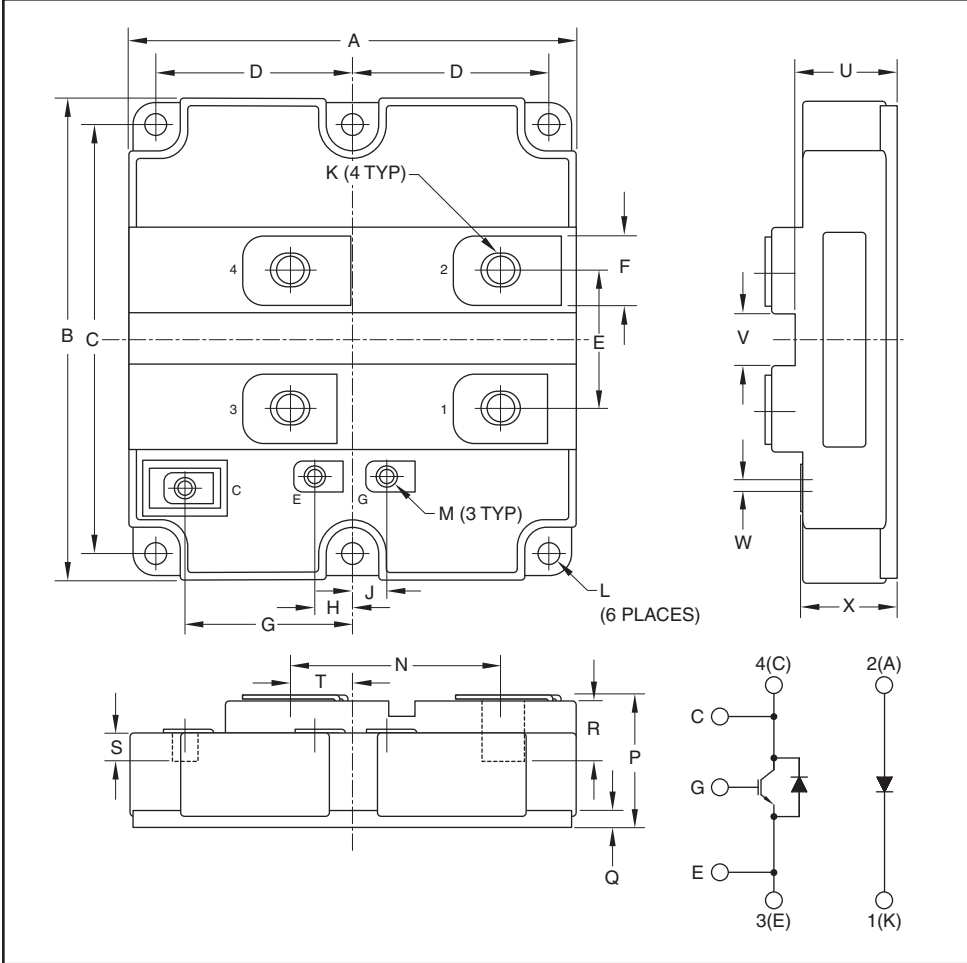

Description:
 Powerex Chopper HVIGBT Modules are designed for use in switching applications. Each module consists of one IGBT Transistor having a reverse-connected super-fast recovery free-wheel diode and an anode-collector connected super-fast recovery free-wheel diode. All components and interconnects are isolated from the heat sinking baseplate, offering simplified system assembly and thermal management.

- Features:**
- Low Drive Power
 - Low $V_{CE(sat)}$
 - Super-Fast Recovery Free-Wheel Diode
 - Isolated Baseplate for Easy Heat Sinking

- Applications:**
- Traction
 - Medium Voltage Drives
 - High Voltage Power Supplies

Ordering Information:
 Example: Select the complete module number you desire from the table below -i.e. CM1200E4C-34N is a 1700V (V_{CES}), 1200 Ampere Chopper HVIGBT Power Module.

Outline Drawing and Circuit Diagram

Dimensions	Inches	Millimeters
A	5.19±0.02	130.0±0.5
B	5.51±0.02	140.0±0.5
C	4.88±0.01	124.0±0.25
D	2.24±0.01	57.0±0.25
E	1.57±0.008	40.0±0.2
F	0.79±0.004	20.0±0.1
G	1.92±0.008	48.8±0.2
H	0.42±0.008	10.65±0.2
J	0.41±0.008	10.35±0.2
K	M8 Metric	M8
L	0.28 Dia.	7.0 Dia.

Dimensions	Inches	Millimeters
M	M4 Metric	M4
N	2.42±0.012	61.5±0.3
P	1.50+0.04/-0.0	38.0+1.0/-0.0
Q	0.2±0.008	5.0±0.2
R	0.65 Min.	16.5 Min.
S	0.30 Min.	7.7 Min.
T	0.71±0.008	18.0±0.2
U	1.16±0.02	29.5±0.5
V	0.60±0.008	15.0±0.2
W	0.21±0.008	5.2±0.2
X	1.10+0.04/-0.0	28.0+1.0/-0.0

Type	Current Rating Amperes	V_{CES} Volts (x 50)
CM	1200	34



Powerex, Inc., 173 Pavilion Lane, Youngwood, Pennsylvania 15697 (724) 925-7272 www.pwr.com

CM1200E4C-34N
Chopper HVIGBT Module
1200 Amperes/1700 Volts

Absolute Maximum Ratings, $T_j = 25^\circ\text{C}$ unless otherwise specified

Characteristics	Symbol	Rating	Units
Collector-Emitter Voltage ($V_{GE} = 0\text{V}$)	V_{CES}	1700	Volts
Gate-Emitter Voltage ($V_{CE} = 0\text{V}$)	V_{GES}	± 20	Volts
Collector Current ($T_C = 75^\circ\text{C}$)	I_C	1200	Amperes
Collector Current (Pulse)* ¹	I_{CM}	2400	Amperes
Emitter Current	I_E^{*2}	1200	Amperes
Emitter Current (Pulse)* ¹	I_{EM}^{*2}	2400	Amperes
Maximum Power Dissipation ($T_C = 25^\circ\text{C}$, IGBT Part)* ³	P_C^{*3}	6500	Watts
Junction Temperature	T_j	-40 to +150	$^\circ\text{C}$
Operating Temperature	T_{op}	-40 to +125	$^\circ\text{C}$
Storage Temperature	T_{stg}	-40 to +125	$^\circ\text{C}$
Isolation Voltage (RMS, Sinusoidal, $f = 60\text{Hz}$, 1 minute)	V_{ISO}	4000	Volts
Maximum Short Circuit Pulse Width ($V_{CC} = 1200\text{V}$, $V_{CES} \leq 1700\text{V}$, $V_{GE} = 15\text{V}$, $T_j = 125^\circ\text{C}$)	t_{psc}	10	μs

*¹ Pulse width and repetition rate should be such that device junction temperature (T_j) does not exceed $T_{opr(max)}$ rating (125°C).

*² Represent ratings and characteristics of the anti-parallel, emitter-to-collector clamp diode.

*³ Junction temperature (T_j) should not increase beyond maximum junction temperature $T_{j(max)}$ rating (150°C).

CM1200E4C-34N
Chopper HVIGBT Module
 1200 Amperes/1700 Voltst

Electrical Characteristics, $T_j = 25^\circ\text{C}$ unless otherwise specified

Characteristics	Symbol	Test Conditions	Min.	Typ.	Max.	Units
Collector Cutoff Current	I_{CES}	$V_{CE} = V_{CES}, V_{GE} = 0V$	—	—	4	mA
Gate-Emitter Threshold Voltage	$V_{GE(th)}$	$I_C = 120mA, V_{CE} = 10V$	6.0	7.0	8.0	Volts
Gate Leakage Current	I_{GES}	$V_{GE} = V_{GES}, V_{CE} = 0V$	—	—	0.5	μA
Collector-Emitter Saturation Voltage	$V_{CE(sat)}$	$I_C = 1200A, V_{GE} = 15V, T_j = 25^\circ\text{C}^{*4}$	—	2.15	2.80	Volts
		$I_C = 1200A, V_{GE} = 15V, T_j = 125^\circ\text{C}^{*4}$	—	2.40	—	Volts
Input Capacitance	C_{ies}		—	176	—	nF
Output Capacitance	C_{oes}	$V_{CE} = 10V, f = 100kHz, V_{GE} = 0V$	—	9.6	—	nF
Reverse Transfer Capacitance	C_{res}		—	2.8	—	nF
Total Gate Charge	Q_g	$V_{CC} = 850V, I_C = 1200A, V_{GE} = 15V$	—	6.8	—	μC
Emitter-Collector Voltage	V_{EC}^{*2}	$I_E = 1200A, V_{GE} = 15V, T_j = 25^\circ\text{C}^{*4}$	—	2.60	3.30	Volts
		$I_E = 1200A, V_{GE} = 15V, T_j = 125^\circ\text{C}^{*4}$	—	2.30	—	Volts
Turn-on Delay Time	$t_{d(on)}$	$V_{CC} = 850V, I_C = 1200A, V_{GE} = \pm 15V,$	—	1.00	—	μs
Turn-on Rise Time	t_r	$R_{G(on)} = 0.6\Omega, T_j = 125^\circ\text{C}, L_S = 150nH,$	—	0.40	—	μs
Turn-on Switching Energy	E_{on}	Inductive Load	—	380	—	mJpulse
Turn-off Delay Time	$t_{d(off)}$	$V_{CC} = 850V, I_C = 1200A, V_{GE} = \pm 15V,$	—	1.20	—	μs
Turn-off Fall Time	t_f	$R_{G(off)} = 3.3\Omega, T_j = 125^\circ\text{C}, L_S = 150nH,$	—	0.30	—	μs
Turn-off Switching Energy	E_{off}	Inductive Load	—	360	—	mJpulse
Reverse Recovery Time	t_{rr}^{*2}	$V_{CC} = 850V, I_C = 1200A,$	—	1.00	—	μs
Repetitive Reverse Current	I_{rr}^{*2}	$V_{GE} = \pm 15V, R_{G(on)} = 0.6\Omega,$	—	560	—	Amperes
Reverse Recovery Charge	Q_{rr}^{*2}	$T_j = 125^\circ\text{C}, L_S = 150nH,$	—	300	—	μC
Reverse Recovery Energy	E_{rec}^{*2}	Inductive Load	—	220	—	mJpulse
Forward Voltage	V_F^{*5}	$I_E = 1200A, V_{GE} = 0V, T_j = 25^\circ\text{C}^{*4}$	—	2.60	3.30	Volts
		$I_E = 1200A, V_{GE} = 0V, T_j = 125^\circ\text{C}^{*4}$	—	2.30	—	Volts
Reverse Recovery Time	t_{rr}^{*5}	$V_{CC} = 850V, I_C = 1200A,$	—	1.00	—	μs
Reverse Reverse Current	I_{rr}^{*5}	$V_{GE} = \pm 15V, di/dt = 2900A/\mu s,$	—	560	—	Amperes
Reverse Recovery Charge	Q_{rr}^{*5}	$T_j = 125^\circ\text{C}, L_S = 150nH,$	—	300	—	μC
Reverse Recovery Energy	E_{rec}^{*5}	Inductive Load	—	220	—	mJpulse

*2 Represent ratings and characteristics of the anti-parallel, emitter-to-collector clamp diode.

*4 Pulse width and repetition rate should be such as to cause negligible temperature rise.

*5 Represent characteristics of the clamp diode.

CM1200E4C-34N
Chopper HVIGBT Module
 1200 Amperes/1700 Volts

Thermal Resistance Characteristics

Thermal Resistance, Junction to Case	$R_{th(j-c)Q}$	IGBT Part	—	—	19.0	K/kW
Thermal Resistance, Junction to Case	$R_{th(j-c)D}$	FWDi Part	—	—	42.0	K/kW
Thermal Resistance, Junction to Case	$R_{th(j-c)D}$	Clamp-Di Part	—	—	42.0	K/kW
Contact Thermal Resistance, Case to Fin	$R_{th(c-f)}$	$\lambda_{grease} = 1W/m \cdot K$	—	16.0	—	K/kW

Mechanical Characteristics

Mounting Torque	M	Main Terminals, M8 Screw	—	177	—	in-lb
		Mounting Screw, M6	—	53	—	in-lb
		Auxiliary Terminals, M4 Screw	—	27	—	in-lb
Weight	m		—	0.8	—	kg
Comparative Tracking Index	CTI		600	—	—	—
Clearance Distance in Air	d_a		19.5	—	—	mm
Creepage Distance Along Surface	d_s		32.0	—	—	mm
Internal Inductance	$L_{C-E(int)}$	IGBT Part	—	30	—	nH
Internal Lead Resistance	$R_{C-E(int)}$	TC = 25°C	—	0.28	—	mΩ

CM1200E4C-34N
Chopper HVIGBT Module
 1200 Amperes/1700 Voltst

OUTPUT CHARACTERISTICS (TYPICAL)

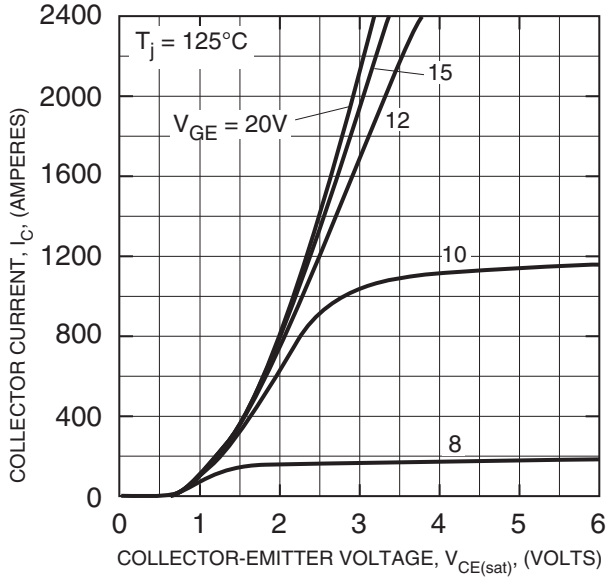

TRANSFER CHARACTERISTICS (TYPICAL)

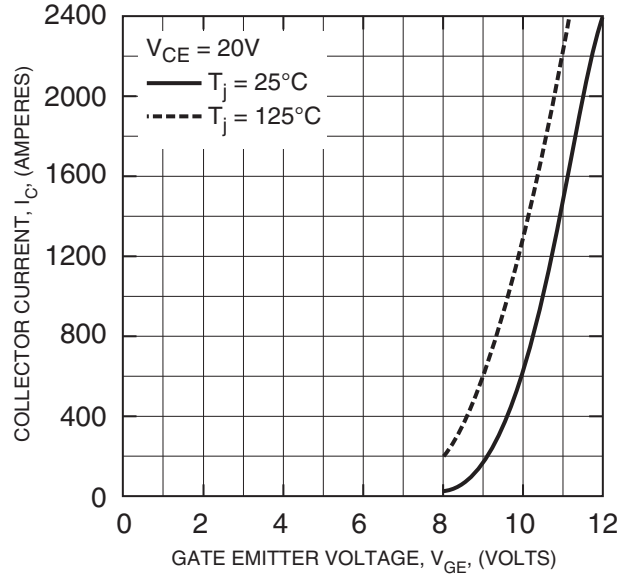

COLLECTOR-EMITTER SATURATION VOLTAGE CHARACTERISTICS (TYPICAL)

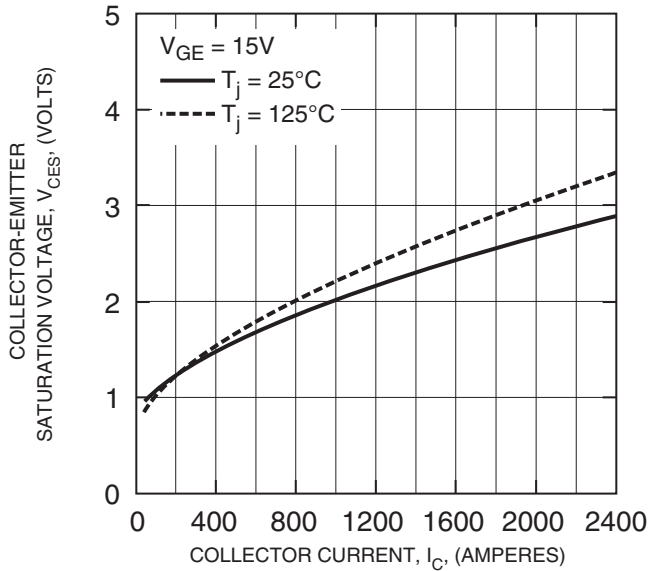

FREE-WHEEL DIODE FORWARD CHARACTERISTICS (TYPICAL)

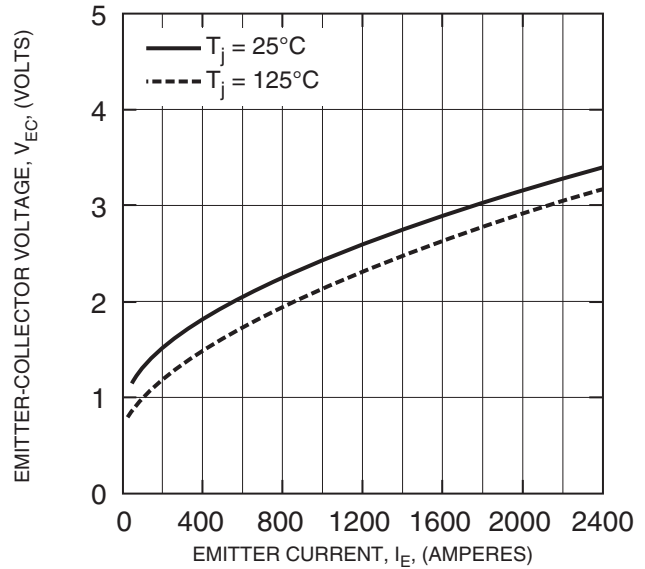

CM1200E4C-34N
Chopper HVIGBT Module
 1200 Amperes/1700 Volts

CAPACITANCE VS. V_{CE}
 (TYPICAL)

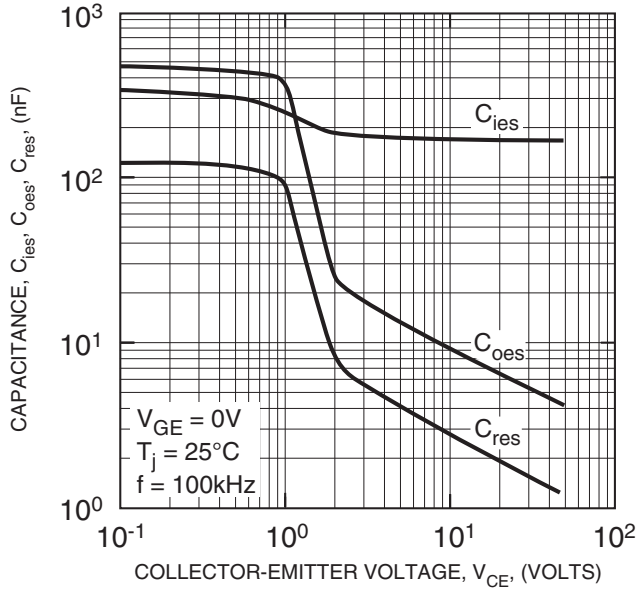

GATE CHARGE CHARACTERISTICS
 (TYPICAL)

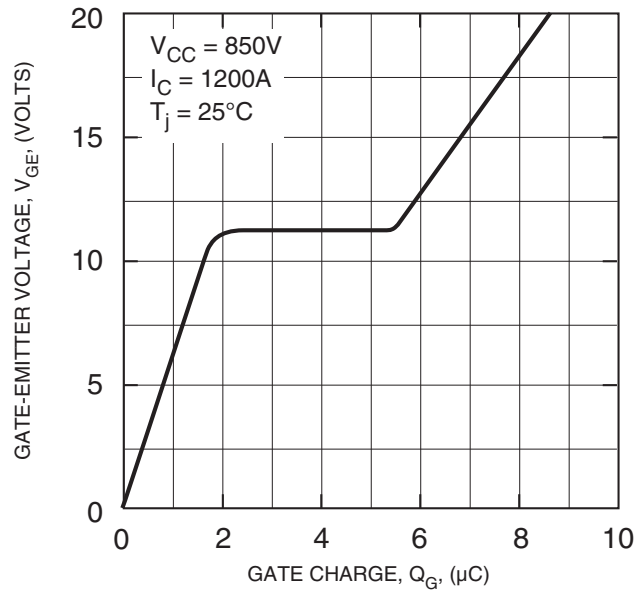

HALF-BRIDGE SWITCHING CHARACTERISTICS
 (TYPICAL)

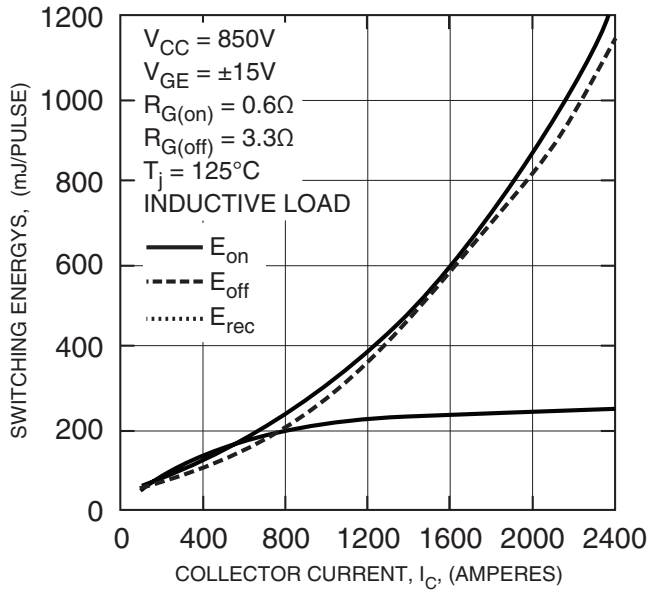

HALF-BRIDGE SWITCHING CHARACTERISTICS
 (TYPICAL)

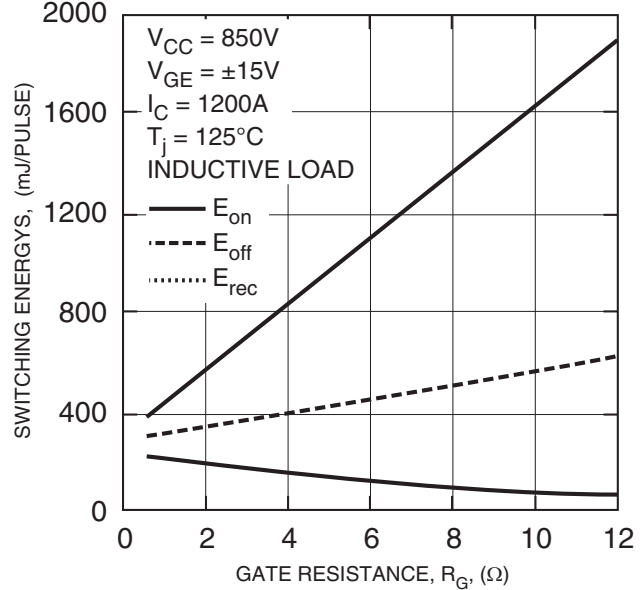

CM1200E4C-34N
Chopper HVIGBT Module
 1200 Amperes/1700 Voltst

**HALF-BRIDGE
 SWITCHING CHARACTERISTICS
 (TYPICAL)**

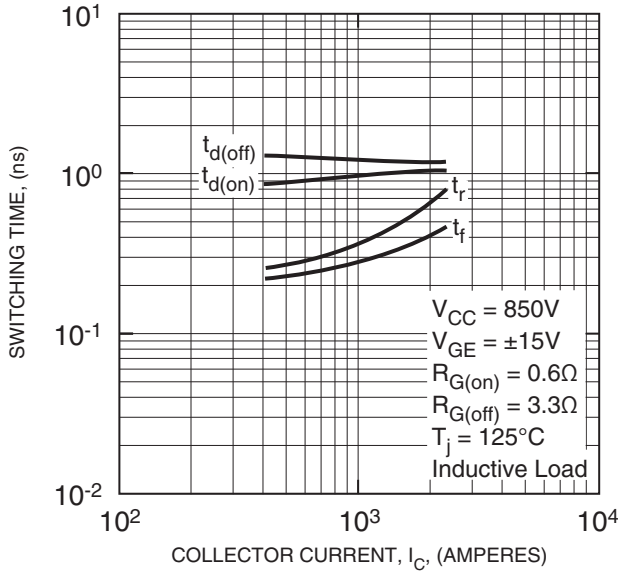

**REVERSE RECOVERY CHARACTERISTICS
 (TYPICAL)**

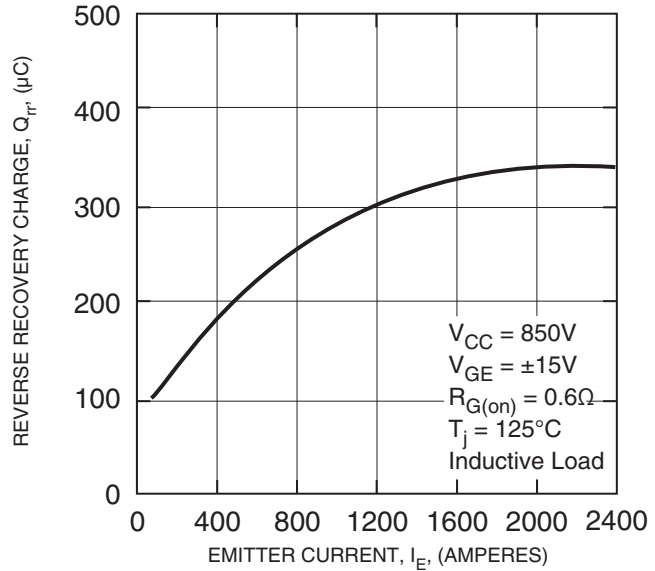

**TRANSIENT THERMAL
 IMPEDANCE CHARACTERISTICS
 (MAXIMUM)**

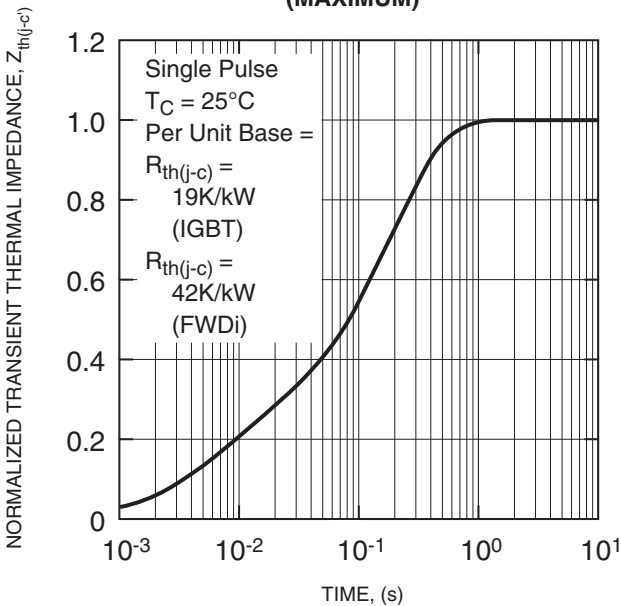

**REVERSE BIAS
 SAFE OPERATING AREA
 (RBSOA)**

