



CH224ATF

Complete 2400 bps Modem Module

INTRODUCTION

The CH224ATF is a complete FCC Part 68 pre-approved, 2400 bps full function modem solution; incorporating an on-board Data Access Arrangement (DAA) in a small footprint, socket-able packaging format (2.5" L x 1.0 W x 0.45" H).

This product is specifically designed for use as direct re-placement for Conexant/Rockwell's SocketModem™ (serial TTL I/O option, Part No. SF224ATF-H1-D5-A0-P1).

This modem provides a fast and convenient way to integrate a PSTN connectivity into any OEM product while utilizing a small portion of PCB area. The CH224ATF requires two external interfaces: a CCITT V.24 serial interface that is routed directly from the UART or UART interface, and a TIP and RING interface, which is connected directly to a conventional RJ-11 jack for the PSTN line connection. The CH224ATF also has various indicator and status lines to monitor operations or to establish triggers. The CH224ATF modem is controlled by industry standard "AT" commands and is compatible with available industry communication software.

The device supports asynchronous operation at 2400 bps, 1200 bps, and 300 bps to both Bell and CCIT standards. The resident PSTN line interface is FCC Part 68 approved, and is also Canadian DOC approveable, and can be approved in other countries that require 1500VAC RMS isolation.

FEATURES

- FCC Part 68 pre-approved
- UL1950, 3rd edition listed
- 1500 Vrms isolation
- Complete solution: on-board DAA
- Data modes
 - CCITT v.22 bis (2400 bps), V.22 (1200 bps)
 - Bell 212A (1200 bps) and 103 (300 bps)
 - Enhanced AT commands
- Group 3 fax modes
 - V.29 (6900/7200 bps) transmit
 - V.27 ter (4800/2400 bps) transmit and receive
 - V.21 Channel 2 (300 bps) transmit and receive
- EIA-578 Service Class 1 commands
- V.42/MNP2-4 and V.42 bis/MNP5 support without additional hardware
- Data/fax discriminator and auto answering
- Communications software compatible
- Serial asynchronous DTE interface
- NVRAM interface allows storage of two user configurations and four 36-digit dial strings
- Automatic adaptive/ fixed compromise equalization
- Programmable sleep mode
- Full-duplex data mode test capabilities: Analog loop, local digital loop, and remote digital loop
- Half-duplex fax mode test capabilities
- Automatic format/speed sensing
- Low power consumption (typical):

Interface	Operating	Sleep
Serial TTL:	155mW	35mW

- Single +5VDC power supply

PART NUMBER ORDERING INFORMATION

Part Number	Description
CH224ATF	Data/Fax modem module with TTL serial interface, on-board DAA, 0.310" pins

TECHNICAL SPECIFICATIONS

General

The CH224ATF modem is a full-featured, self-contained data/fax solution. External micro-controller for data or fax control functions are fully supported and controlled through the AT command set.

Data modes perform complete handshake and data rate negotiations. All tone and pattern detection required by the applicable CCITT or Bell standard are supported.

Fax modes support Group 3 fax requirements. Fax data and fax control (V.21 300 bps) performed by the modem is controlled and monitored through the fax EIA-578 Class 1 insertion/deletion, and CRC generation/checking is provided.

Both transmit and receive fax data is buffered within the modem. Data transfer to and from the DTE is flow controlled by XON/XOFF.

Configurations and Rates

The supported modem configurations and signaling rates are listed in Table 1. In data modes with serial interface selected, DTE rate offsets of +1%, -2.5% are accommodated by adding/deleting stop bits are required. In fax modes, the DTE rate is 19200 bps.

Operation

Modem operation is controlled by AT commands (Table 2), fax service class 1 commands (Table 3), and supporting S registers (Table 4). Result codes and messages are listed in Table 5.

Data Modes: Data rate selection is determined by the speed of the originating and answering modems:

Originate Modem Rate (bps)	Connect Speed Based on Answer Modem Rate (bps)		
	300	1200	2400
300	300	300	300
1200	1200	1200	1200
2400	1200	1200	2400

Fax Modes: Fax modes are negotiated as defined in T.30 and are implemented by AT+F commands. The AT+FCLASS=1 command causes entry into the fax mode from the data mode. Most other fax class 1 commands, which start with the AT+F prefix, are valid only in the fax mode. All data commands are valid in the fax mode except A/, On & Tn, and the escape sequence (+++). The AT+FCLASS=0 command terminates the fax mode and causes entry into the data mode.

Table 1. Configurations and Rates

Configuration	Modulation	Transmitter Carrier Frequency (Hz) $\pm 0.01\%$		Data Rate (bps)	Baud (Symbols/Sec.)	Bits Per Symbol	Constellation Points	
		Answer	Originate					
Data Mode	V.22	QAM	2400	1200	2400	600	4	16
	V.22	DPSK	2400	1200	1200	600	2	4
	Bell 212A	DPSK	2400	1200	1200	600	2	4
	Bell 103	FSK	2225	1270 M	300	300	1	1
			2025 S	1070 S				
Fax Mode	V.29	QAM	N/A	1700	9600	2400	4	16
	V.22	DPSK	N/A	1700	7200	2400	3	8
	Bell 212A	DPSK	1800	1800	4800	1600	3	8
	Bell 103	FSK	1800	1800	2400	1200	2	4
			1650 M	1650 M	300	300	1	1
		1850 S	1850 S					

Notes:

Legend: QAM = Quadrature Amplitude Modulation M = Mark Condition
 DPSK = Differential Phase Shift Keying S = Space Condition
 FSK = Frequency Shift Keying N/A = Not Applicable

Table 2. “AT” Command Set Summary

Command	Function
A/	Re-execute command
A	Answer a call
Bn	Select CCITT or Bell Mode
Cn	Carrier control
Dn	Dial modifier
En	Command echo
F1	On-line character echo option
Hn	Disconnect (Hangup)
In	Identification
Ln	Speaker volume
Mn	Speaker control
On	Go on-line
P	Force pulse dialing
Qn	Quiet Result codes control
Sn	Select S register as default
Sn=v	Set default S register to value
Sn?	Return the value of S register
T	Force DTMF dialing
Vn	Report codes form
Xn	Extended result codes
Yn	Long space disconnect
Zn	Soft reset and restore profile
&Cn	RLSD (DCD) option
&Dn	DTR option
&F	Recall (restore)factory profile
&Gn	Select guard tone
&Jn	Telephone jack control
&L0	Dial-up line operation
&M0	Asynchronous mode
&Pn	Pulse dial make/break ratio
&Q0	Asynchronous mode
&Sn	DSR override
&Tn	Test and diagnostic
&V	Display current configurations
&Wn	Store current configuration
&X0	Asynchronous data transmission
&Yn	Select default profile
&Zn=x	Store dial string to location n
%Dn	DTMF Level Attenuation
%J	Load Secondary Defaults
%Ln	Transmit Level Attenuation
Dial Modifier	Function
P	Pulse Dial
R	Originate Call in Answer Mode
S=n	Dial Stored Number
T	Tone Dial
W	Wait for Dial Tone
;	Return to Idle State
@	Wait for Quiet Answer Command
!	Flash Hook
,	Pause
0-9, A, B, C, D, #, *	Dial Digits/ Characters

Table 3. Fax Command Set Summary

Fax Command	Function
+FCLASS=n	Service class
+F<command>?	Report Active Configuration
+F<command>=?	Report Operating Capabilities
+FAA=n	Data/Fax Auto Answer
+FF	Enhanced flow Control
+FTS=n	Stop Transmissions & Wait
+FRS=n	Receive Silence
+FTM=n	Transmit Data
+FRM=n	Receive Data
+FTH=n	Transmit Data with HDLC Framing
+FRH=n	Receive Data with HDLC Framing
+FRTn	Receive Test Data
+FTTn=m	Transmit Test Data
+Hn	Rockwell Protocol Interface (RPI Enable)

Table 4. Register Summary

Register	Function
S0*	Rings to Auto-Answer
S1	Ring Counter
S2	Escape Character
S3	Carriage Return Character
S4	Line Feed Character
S5	Backspace Character
S6	Maximum time to Wait for Dial Tone
S7	Wait for Carrier
S8	Pause Time for Comma
S9	Carrier Detect Response Time
S10	Carrier Loss Disconnect Time
S11	DTMF dialing Speed
S12	Escape Prompt Delay
S14*	General Bit mapped Options
S16	Test Mode Bit Mapped Options (&T)
S17	Fax Mode Null Byte Timer
S18*	Test Timer
S19	Rockwell Protocol Interface Speed
S20	Fax Mode Inactivity Timer
S21*	General bit Mapped Options
S22*	General bit Mapped Options
S23*	General Bit Mapped Options
S24	Sleep Inactivity Timer
S25*	Delay to DTR Off
S26*	RTS-to-CTS Delay
S27*	General Bit Mapped Options
S28*	General Bit-Mapped Options

* Register value may be stored in one of two user profiles with the AT&W command.

Table 5. Results Codes & Messages

Digit Code	Word Code	Meaning
0	OK	Command line executed without errors
1	CONNECT	Connection at 300bps
2	RING	Ring signal detected
3	NO CARRIER	Carrier lost or never present
4	ERROR	Invalid command, checksum, error in command line, or command line exceeds 40 characters
5	CONNECT 1200	Connection at 1200 bps
6	NO DIAL TONE	No dialtone detected
7	BUSY	Busy signal detected
8	NO ANSWER	No silence detected when dialing a system not providing a dialtone
10	CONNECT 2400	Connection at 2400 bps
+F4	+FCERROR	Fax carrier error
13	DATA	Connected as data modem during auto answer
15	FAX	Connected as fax modem during auto answer
Data/Fax Auto Answering		
The modem can automatically determine if the incoming call is from a data or fax modem, make the appropriate connection, and inform the DTE of the connection type.		

AT Command Format

Each command line must start with the AT prefix and be terminated with a carriage return (CR). Several commands may be included on one command line. A command line may contain up to 40 characters excluding the AT prefix and the terminating CR. A separator is not required between data commands. A semicolon (;) separator is required between fax commands.

AT commands are composed of 10-bit ASCII encoded asynchronous characters. The character format in data mode is 8 data bits with no parity, or 7 data bits with even, odd, or no (two stop bits) parity, at a data rate of 19200, 2400, 1200, or 300 bps. The character format in fax mode is 8 data bits with no parity at 19200 bps.

Data Modulation

The data modulation conforms to V.29, V.27 ter, V.22 bis, V.22, V.21, Bell212A, or Bell 103, depending on the selected configuration. Transmitter and receiver spectrum shaping is provided in accordance with the applicable standard.

Equalization

Automatic adaptive equalization as well as fixed compromised equalization is provided to compensate for line distortions and to minimize the effects of the intersymbol interference.

Scrambler/Descrambler

The modem incorporates a self-synchronizing scrambler/ descrambler satisfying the applicable CCITT or Bell requirements.

Transmit Level

The transmit level is $-10 \text{ dBm} \pm 1 \text{ dB}$ (at TIP and RING).

Answer Tone: An answer tone of 2100 Hz (V.22bis, V.22, or T.30) or 2225 Hz (Bell 212A or 103) is generated.

Guard Tone: An 1800 Hz guard tone can be generated in all data modes.

Calling Tone: A 1100 Hz (0.5 seconds on, 3 seconds on, 3 seconds off) calling tone (T.30) is generated in the originate fax mode.

Receive Level

The receiver satisfies performance requirements for a received signal from -9 dBm to -43 dBm . The carrier detect is ON at -43 dBm and OFF at -48 dBm with a minimum of 2 dB hysteresis.

Receiver Tracking

The modem can accommodate carrier frequency offset up to $\pm 7 \text{ Hz}$, and a transmit timing error of $\pm 0.01\%$ (V.22 bis or V.27 ter) or $\pm 0.02\%$ (V.22 or Bell 212A).

Low Power Sleep Mode

To conserve power, the CH224ATF is configured for idle (power down) mode. Idle mode is entered whenever the modem is inactive beyond the time value specified by S24.

The idle mode allows reduced power consumption with automatic recovery without additional circuitry. The modem exits Idle mode and returns to full operation whenever a ring signal occurs, the DTE writes to the modem (parallel interface), or $\sim\text{DTR}$ or $\sim\text{TXD}$ is asserted (serial interface).

HARDWARE INTERFACE**Serial/Indicator Interfaces**

A DTE serial interface and indicator output are supported.

Serial Interface. A TTL logic serial interface to the DTE is supported.

LED indicator interface. Four direct connect LED indicator outputs are supported.

Speaker Interface

A speaker output, controlled by AT or V.25 bis commands, is provided for an optional OEM-supplied speaker circuit.

Line Interface

The CH224ATF connects to the telco line via tip and ring signals.

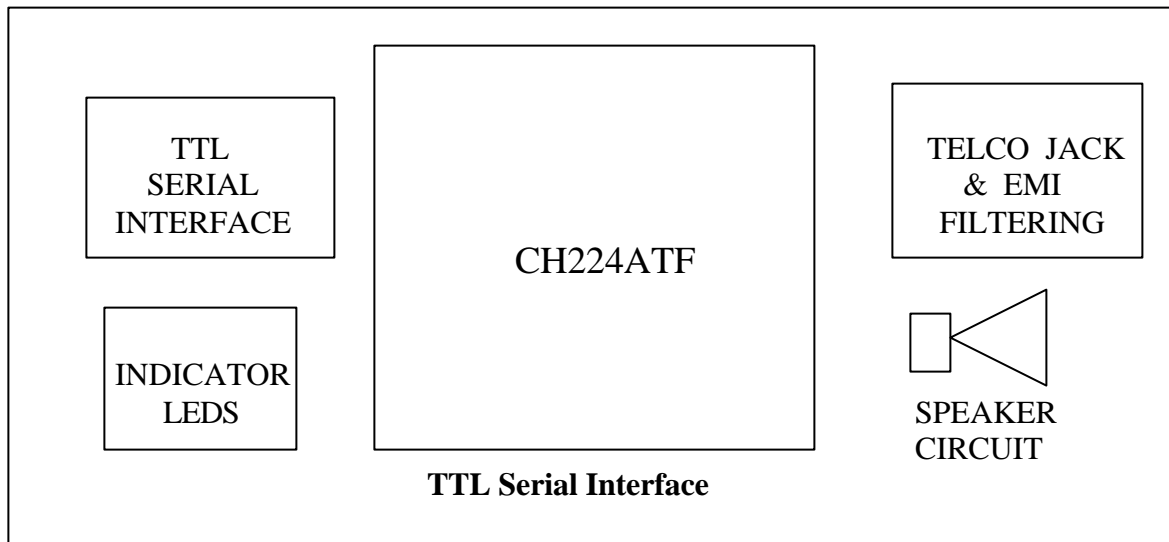

CH224ATF Integrated System Block Diagram

LOW POWER MODES**Sleep mode**

Entry. The modem will enter the low power sleep mode when no line connection exists and no host activity occurs for the period of time specified in the S24 register. All device circuits are turned off except the internal MCU clock circuitry in order to consume lower power, but are able to immediately wake up and resume normal operation.

Wake-up. Wake-up occurs when a ring signal occurs, or the DTE sends a character to the modem.

HARDWARE INTERFACE SIGNALS

The SocketModem pin assignments for serial TTL interface selected are shown in Figure 2 and are listed in Table 7.

The SocketModem hardware interface signals are defined in Table 9.

The digital electrical characteristics for the hardware interface signals are listed in Table 10.

The analog electrical characteristics for the hardware interface signals are listed in Table 11.

The current absolute maximum ratings are listed in Table 13.

Table 7. CH224ATF Serial TTL Signals

Pin	Signal	I/O Type	Pin	Signal	I/O Type
1	TIP	IF	33	NC	-
2	RING	IF	34	~RXDTTL	OA
3	NO PIN	-	35	~TXDTTL	IA
4	NO PIN	-	36	~RITTL	OA
5	NO PIN	-	37	~DSRTTL	OA
6	NO PIN	-	38	~CTSTTL	OA
7	NO PIN	-	39	~DCDTTL	OA
8	NO PIN	-	40	~DTRTTL	IA
9	NO PIN	-	41	DGROUND	GND
10	NO PIN	-	42	NO PIN	-
11	NO PIN	-	43	NO PIN	-
12	NO PIN	-	44	NO PIN	-
13	NO PIN	-	45	NO PIN	-
14	NO PIN	-	46	NO PIN	-
15	NO PIN	-	47	NO PIN	-
16	NO PIN	-	48	NO PIN	-
17	NO PIN	-	49	NO PIN	-
18	NO PIN	-	50	NO PIN	-
19	NO PIN	-	51	NO PIN	-
20	NO PIN	-	52	NO PIN	-
21	NO PIN	-	53	NO PIN	-
22	NO PIN	-	54	NO PIN*	-
23	NO PIN	-	55	NO PIN*	-
24	~RESET	IC	56	NO PIN*	-
25	NO PIN	-	57	NO PIN*	-
26	DGROUND	GND	58	NO PIN*	-
27	NC	-	59	NO PIN*	-
28	NO PIN*	-	60	NO PIN*	-
29	DCDIND	OG	61	VCC	PWR
30	RXDIND	OG	62	NC	-
31	~DTRIND	OG	63	AGROUND	GND
32	TXIND	OG	64	SPKR	O(DF)
* It is suggested that a hole be placed in the host board for upgrade purposes.					

Table 9. Signal Designations

Label	I/O	Signal Name Designation
		The Serial Interface signals are all TTL-level.
~RXDTTL	OA	Received Data. Active low. The modem uses the ~RXD line to send data received from the telephone line to the DTE and to send modem responses to the DTE. During command mode, ~RXD data represents the modem responses to the DTE. Modem responses take priority over incoming data when the two signals are in competition for ~RXD.
~TXDTTL	IA	Transmitted Data. Active low. The DTE uses the ~TXD line to send data to the modem for transmission over the telephone line or to transmit commands to the modem. The DTE should hold this circuit in the mark state when no data is being transmitted or during intervals between characters.
~RITTL	OA	Ring Indicate. Active low. ~RI output ON (low) indicates the presence of an ON segment of a ring signal on the telephone line. The modem will not go off-hook when ~RI is active; the modem waits for ~RI to go inactive before going off-hook. For US models, ~RI will respond to ring signals in the frequency range of 15.3 Hz to 68 Hz. The ring signal cycle is typically two seconds ON, four seconds OFF. The OFF (high) condition of the ~RI input should be maintained during the OFF segment of the ring cycle (between rings) and at all other times when ringing is not being received.
~DSRTTL	OA	Data Set Ready. Active low. ~DSR indicates modem status to the DTE. ~DSR OFF (high) indicates that the DTE is to disregard all signals appearing on the interchange circuits except Ring indicator (~RI). ~DSR output is controlled by the AT&Sn command. If the AT&S1 option is selected, ~DSR will come ON in the handshaking state when carrier is detected in the originate mode or when carrier is first sent in the answer mode. In addition if a test mode is entered (AT&T1, AT&T3, AT&T6-AT&T8), ~DSR will go off while the test is running. ~DSR goes OFF if ~DTR goes OFF. If AT&Q0 and AT&S0 are selected, ~DSR will remain on at all times regardless of the modem's current state.
~CTSTTL	OA	Clear To Send. Active low. ~CTS is controlled by the modem to indicate whether or not the modem is ready to transmit data. CTS OFF indicates to the DTE that it should not transfer data across the interface on TXD. In data modes, the ~CTS output is always ON. In fax modes, ~CTS is optionally used for flow control.
~DCDTTL	OA	Data Carrier Detect. Active low. When AT&C0 commands is not in effect, ~DCD output is ON when a carrier is detected on the telephone line or OFF when carrier is not detected. ~DCD can be strapped ON using AT&C0 command.
~DTRTTL	IA	Data Terminal Ready. Active low. The ~DTR input is turned ON (low) by the DTE when the DTE is ready to transmit or receive data. ~DTR ON prepares the modem to be connected to the telephone line, and maintains the connection established by the DTE (manual answering) or internally (automatic answering). ~DTR OFF places the modem in the disconnect state under control of the &DN and &Qn commands. The effect of ~DTR ON and ~DTR OFF depends on the &Dn and &Qn commands. Automatic answer is enabled when ~DTR is ON if the "Answer Ring count" selectable option is not set to 0. Regardless of which device is driving ~DTR, the modem will respond to an incoming

		ring by going off-hook and beginning the handshake sequence. The response of the modem to the ~DTR signal is very slow (up to 10 ms) to prevent noise from falsely causing the modem to disconnect from the telephone line.
GND	GND	Ground
		LED drivers are open-drain inverter-driven (74HCT05) lines with 1.5K ½, 1/10W pull-up resistors on-board.
DCDIND	OG	DCD LED indicator. Active high DCD status.
RXDIND	OG	RXD LED indicator. Active high RXD status.
~DTRIND	OG	DTR LED indicator. Active high TXD status.
SPKR	O(DF)	Speaker Analog Output. The SPKR output reflects the received analog input signal. The SPKR is controlled by the ATMn command. SKR is tied directly to SPKR pin of the data pump.

Table 10. Digital Interface Characteristics

Parameter	Sy mb ol	Min.	Typ.	Max.	Units	Test Conditions
Input High Voltage Type IA Type IC Type IH	V_{IH}	2.0 3.5 -30	- - -	V_{CC} V_{CC} 30	Vdc	
Input Low Voltage Type IA and IC	V_{IL}	-0.3	-	0.8	Vdc	
Input Low Voltage Type IF	V_{IL}	38	-	-	Vrms	Note2
Input Leakage Current IA and IC	I_{IN}	-	-	± 10	μA_{dc}	$V_{IN}=0$ to V_{CC}
Output High Voltage Type OA Type OD Type OG	V_{OH}	2.4 - -	- - -	- V_{CC}^V CC	Vdc	I _{LOAD} = 100 μ A I _{LOAD} = 0 mA
Output Low Voltage Type OA Type OB Type OD Type OG	V_{OL}				Vdc	I _{LOAD} = 1.6 mA I _{LOAD} = 0.8 mA I _{LOAD} = 15 mA I _{LOAD} = 8 mA
Three -State (Off) Current	I_{TS}			± 25	μA_{dc}	$V_{IN}=0.8$ V to 4.5V

Notes:

1. Test Conditions: $V_{CC} = 5V \pm 5\%$, $T_A = 0^\circ C$ to $70^\circ C$ (unless otherwise stated.)

Output loads: 50 pF + one TTL.

2. AC V_{rms} voltage between Tip and Ring, using the on-board modular DAA.

Table 11. Analog Characteristics

Name	Type	Characteristic	Value
SPKR	O (DF)	Minimum Load	300Ω
		Maximum Capacitive Load	0.01μF
		Output Impedance	10Ω
		Output Voltage	2.5 ± 1.6V
		D.C Offset	< 20 mV

Table 12. Current and Power Requirements

Mode	Current (ID)		Power (PD)	
	Typical Current @25°C	Maximum Current @0°C	Typical Power @25°C	Maximum Power @0°C
Serial TTL				
Normal mode	31mA	33 mA	155 mW	165 mW
Sleep mode	7 mA	9 mA	35 mW	45 mW

Notes:

1. Test conditions: 5.0 VDC for typical values; VDD = 5.25 for maximum values.

Table 13. Absolute Maximum Ratings

Parameter	Symbol	Limits	Units
Supply Voltage	V _{DD}	-0.5 to +6.0	V
Input Voltage	V _{IN}	-0.5 to (+5VD +0.5)	V
Analog Inputs	V _{IN}	-0.3 to (+5VA +0.3)	V
Voltage Applied to Outputs in High Z State	V _{DD}	-0.5 to (+5VD +0.5)	V
DC Input Clamp Current	I _{IK}	±20	MA
DC Output Clamp Current	I _{OK}	±20	MA
Static Discharge Voltage (@25°C)	V _{ESD}	±2500	V
Latch-Up Current (@25°C)	I _{TRIG}	±400	mA
Operating Temperature Range	T _A	-0 to +70	°C
Storage Temperature Range	T _{STG}	-40 to +80	°C

Figure 5. CH224ATF Physical Dimensions

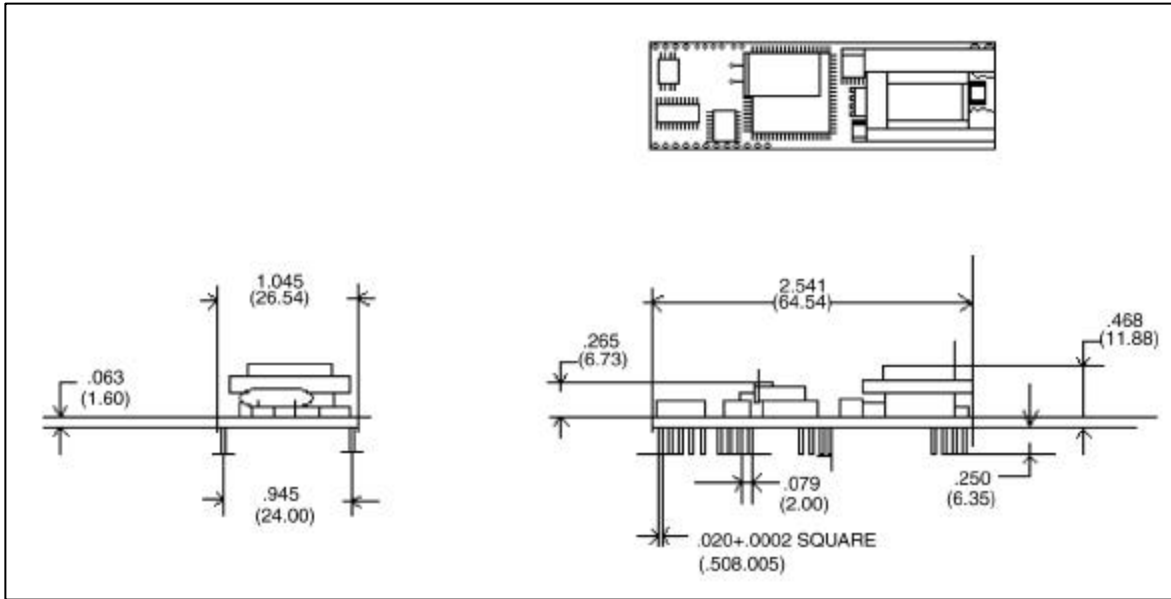

PHONE LINE CONNECTION GUIDELINES

- 1) The CH224ATF must be mounted in the final assembly such that it is isolated from exposure to any hazardous voltages within the assembly. Adequate separation and restraint of cables and cords must be provided.
- 2) The circuitry from the CH224ATF to the telephone line interface must be provided in wiring that carries no other circuitry other than that specifically allowed in the FCC rules (such as A and A1 leads).
- 3) Connection to phone line should be made through an RJ-11C jack.
- 4) PCB traces from the modem's RING and TIP pins to the RJ-11C jack must be 0.1 inch spacing or greater to one another and 0.2 inch spacing or greater to all other traces. The traces should have a nominal width of 0.020 inches or greater.
- 5) The RING and TIP PCB traces should be as short as possible and oriented to prevent coupling other high speed or high frequency signals present on the host circuit PCB.
- 6) No additional circuitry other than that shown in Figure 7A or 7B may be connected between the modem module and the RJ-11C jack. Doing so will invalidate the FCC approval.
- 7) The CH224ATF requires external surge protection (see Figure 7). This is mandatory to maintain FCC Part 68 conveyed approval.
- 8) The CH224ATF, the RJ-11C jack, the interfacing circuitry and all PCB traces in between, must be contained on a PCB with a 94 V-0 flammability rating.
- 9) The supplied FCC registration label must be applied visibly on the outside of the product.
- 10) The product's User Manual must provide the user with instructions for connection and use as recommended in the FCC Registration Section below.

INTERNATIONAL APPROVALS

The CH224ATF can be approved for some international telephone connections. This must be done after the modem is installed in the host product.

The entire host product must be submitted to the country of interest's Telephone Network approval authority. They are available on special order. The end product supplier is responsible for submission of the end product for independent testing and subsequent approval. See Application Cermetek Note #142 for typical telephone requirements.

CH224ATF HANDLING AND ASSEMBLY RECOMMENDATIONS

The CH224ATF contains static-sensitive components and should only be handled by personnel and in areas that are properly protected against static discharge.

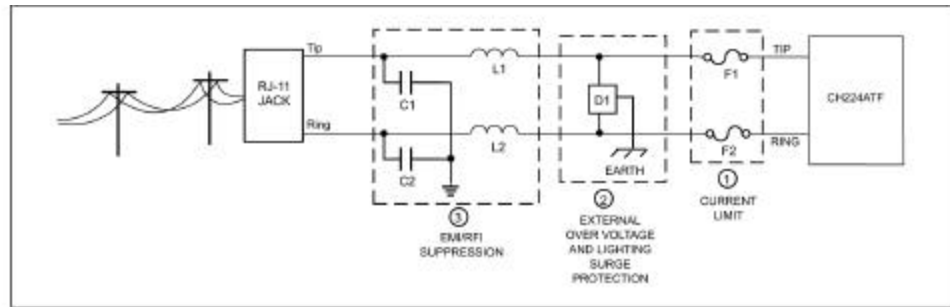

1. **Current Limiting PSTN Protection Line Device.**
Current limiting devices are mandatory to meet UL safety standards. To maintain conveyed FCC Part 68 approval, the current limiting components identified as F1 and F2 in dashed box #1 must also survive FCC Part 68 surge testing. Refer to Cermetek Application Note #126 for more details.
 - A. A Raychem Polyfuse TR 800-150 (rated at 0.15 amps) is preferred because this device resets automatically upon removal of the current flow. Non-resettable devices such as Little Fuse, type 251.250, or Cooper Ind. BUSSMAN type MCR14 are also acceptable.
 - B. Resistors (10Ω carbon film or 1/8 watt minimum) may be used in Canada as Canada has no requirement that PSTN equipment be operational after a Type B surge test.
 - C. Although CSA CS-03 Part 1 (Canada) follows the requirements of FCC Part 68 (USA), Cermetek recommends contacting DOT (Canada) and/or a certified independent lab to verify compliance. For Canada, use either 10Ω resistors (carbon film or SMD parts 1/8 watt minimum) as described in paragraph B above, or non-resettable fuses or resettable Polyfuses as described in paragraph A above.
2. **Over Voltage and Lightning Protection.**
 - A. Over voltage and lightning surge protection is mandatory for FCC Part 68 compliance. The required external surge protection (identified as D1 in dashed box 2) is mandatory and the purchaser must include some form of surge protection as described below to maintain conveyed FCC part 68 approval.
 - B. In most environments, 2 terminal surge suppressors are adequate. For these applications, Cermetek recommends the use of Teccor Sidactor P/N 3100EB or equivalent. For severe environments, use the 3 terminal Teccor Sidactor P/N 3203AB or equivalent.
3. **EMIRFI Suppression.**
No external EMIRFI noise suppression circuitry is required to maintain conveyed FCC Part 68 approval. However, additional suppression, if required for other reasons, may be added as described below in sections 3A-3B without adversely affecting FCC Part 68 approval.
 - A. To provide adequate EMIRFI suppression, the capacitor/inductor network contained in dashed box #3 should be located as close to the RJ11 Jack as possible. Further, this network should be provided with an excellent ground path to the chassis.
 - B. Capacitors C1 and C2 should not exceed 0.005 μf. They must have a rating of 1.5 KV and typically are .001 μf +/- 20%. Recommended devices for inductors L1 and L2 are Fair-Rite 2643666611 or 294366661 or equivalent. For UL applications, choose capacitors and inductors that are UL 1950 listed. The actual values of the components used may vary depending on the end product design.

FCC REGISTRATION

All products in the CH224ATF series are registered with the FCC (Federal Communications Commission) under Part 68. To maintain the validity of the registration, you must serve notice to the end user of the product of several restrictions the FCC places on the modem and its use.

The CH224ATF requires external surge protection (see Figure 7) This is mandatory to maintain FCC Part 68 conveyed approval. Refer to Cermetek Application Note #126 for more details.

In addition to restriction notification, the FCC requires that Cermetek make all repairs to all products in the CH224ATF. If repairs are necessary after installation of the CH224ATF in the end product and the end product has been delivered to the end user, the end product must be returned to the end product supplier where the CH224ATF can be removed and then forwarded to Cermetek for repair. The following notice is recommended and should be included in the end product's user manual.

comply with the mechanical requirements specified in Part 68, Sub-part F, specifically the dimensions, tolerances and metallic plating requirements. The compliance of these connectors will be assured by purchase specifications and incoming inspection. Documentation of such specifications and/or inspections will be provided to the FCC within 30 days of their request for the same.

Telephone Company Procedures: The goal of the telephone company is to provide you with the best service it can. In order to do this, it may occasionally be necessary for them to make changes in their equipment, operations or procedures. If these changes might affect your service or the operation of your equipment, the telephone company will give you notice, in writing, to allow you to make any changes necessary to maintain uninterrupted service.

In certain circumstances, it may be necessary for the telephone company to request information from you concerning the equipment which you have connected to your telephone line. Upon request of the telephone company, provide the FCC registration number and the ringer equivalence number (REN); both of these items are listed on the equipment label. The sum of all of the

FOR YOUR USER 'S MANUAL

The Part 68 rules require the following (or equivalent) be provided to the end user of equipment containing a DAA:

Type of Service: The (insert end product name) is designed to be used on standard device telephone lines. It connects to the telephone line by means of a standard jack called the USOC RJ-11C (or USOC RJ45S). Connection to telephone-company-pro-vided coin service (central office implemented systems) is prohibited. Connection to party lines service is subject to state tariffs.

Changes in Attestation Procedure for Plugs and Jacks:

(Name of applicant) attests that the network interface plugs or jacks used on this equipment comply with and will continue to telephone provider.

REN 's on your telephone lines should be less than five in order to assure proper service from the telephone company. In some cases, a sum of five may not be use-able on a given line. Consult your telephone provider.

If Problems Arise: If any of your telephone equipment is not operating properly, you should immediately remove it from your telephone line, as it may cause harm to the telephone network. If the telephone company notes a problem, they may temporarily discontinue service. When practical, they will notify you in advance of this disconnection. If advance notice is not feasible, you will be notified as soon as possible.

Cermetek reserves the right to make changes in specifications at any time and without notice. The information furnished by Cermetek in this publication is believed to be accurate and reliable. However, no responsibility is assumed by Cermetek for its use, or for any infringements of patents or other rights of third parties resulting from its use. No license is granted under any patents or patent rights of Cermetek.

Printed in U.S.A

406 TASMAN DRIVE | SUNNYVALE CA 94089 | LOCAL: 408-752-5000 | TOLL FREE: 1-800-882-6271 | FAX: 408-752-5004 | WEB SITE: <http://www.cermetek.com> | EMAIL: sales@cermetek.com