

Photosensor amplifier C9051

Small on-board type current-to-voltage conversion amp



C9051 is a current-to-voltage conversion amplifier specifically designed for low-light-level measurement using a photodiode (sold separately).

Features

- Small on-board type for easy assembly
- Usable with photodiodes having large terminal capacitance
- Conversion impedance: 1.0×10^8 V/A
- Single +12 V supply voltage operation
- Small board size: 50 (W) × 50 (H) × 19 (D) mm

Applications

- Low-light-level detection
- Low-light-level optical power meters
- DC light monitors

■ Absolute maximum ratings

Parameter	Symbol	Value	Unit
Maximum voltage	Vcc Max.	+16	V
Operating temperature *1	Topr	0 to +50	°C
Storage temperature *1	Tstg	-10 to +60	°C

*1: No condensation

■ Electrical and optical characteristics (Ta=25 °C, Vcc=+12 V)

Parameter	Symbol	Condition	Min.	Typ.	Max.	Unit
Conversion impedance	Tz		-	1×10^8	-	V/A
Frequency bandwidth	fc	C9051 board, -3 dB	DC	-	16	Hz
Input photocurrent range	Isc	*2	0	-	40	nA
Maximum output amplitude	Vo	RL=1 kΩ	4.0	-	-	V
Output offset voltage	Vos	C9051 board	-5	-	5	mV
Equivalent noise input current	IN	Without photodiode, f=1 Hz	-	-	5×10^{-13}	A/Hz ^{1/2}
Output noise voltage	e _{np-p}	Without photodiode, full bandwidth	-	-	0.5	mVp-p
Output resistance	Ro		-	100	-	Ω
Maximum input capacitance	CIN		-	-	15	nF
Maximum capacitive load	CL		-	-	1000	pF
Current consumption	Icc	Without photodiode	-	-	20	mA
Supply voltage	Vcc	*3	+9	+12	+15	V
Power supply ripple voltage	Vcc RIPPLE	*4	-	-	200	mVp-p

*2: When connecting a photodiode to C9051, the cathode should be connected to the IN terminal of C9051 and the anode grounded. Photocurrent input from the photodiode will be negative with respect to the amplifier.

*3: If not using the AC adapter that comes with C9051, set the power supply voltage within this range. A separate adapter plug will be required for power input to C9051.

*4: This is the maximum ripple allowed for the power supply when operated with all loads listed on the power supply specification sheet, excluding switching noise that might appear superimposed on the ripple. When not using the AC adapter that comes with C9051, always make sure that the power supply output does not contain excessive ripple and noise.

■ Usable photodiodes

Any single-element photodiode with a terminal capacitance below 15 nF can be used.

In photometric applications requiring high accuracy, we recommend using metal package or ceramic package photodiodes. For detailed information refer to individual data sheets for our photodiodes.

NOTE) C9051 cannot be used with multi-element photodiodes, photodiodes with preamplifier, APD (avalanche photodiodes), photo IC diodes and reverse-biased photodiodes.

■ Connection example

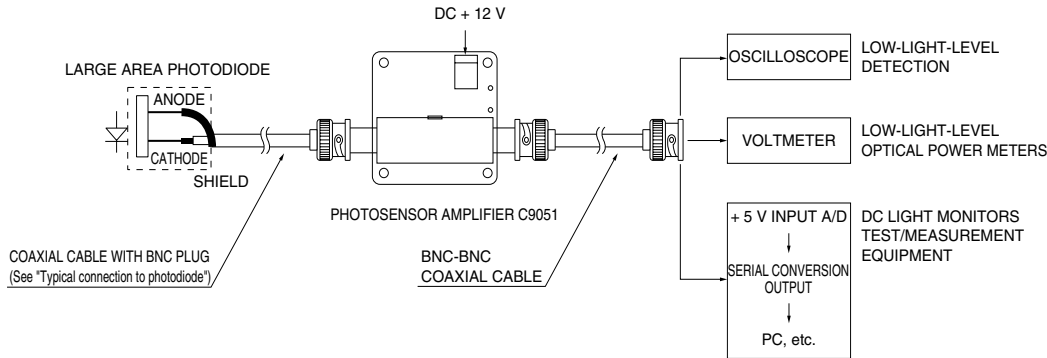

■ Typical connection to photodiode

- To connect a photodiode to C9051, use a coaxial cable terminated with a BNC plug. The cable length (capacitance) should be less than 15 nF including photodiode terminal capacitance.
- Solder the photodiode leads to connect the tip of the cable wire. (See the drawing on the right.)
 Anode: Connect to the shield wire of the cable. (Make electrical connection with the shield.)
 Cathode: Connect to the core wire of the cable.
- To improve measurement accuracy, provide a shield around the photodiode. Do not use a cable any longer than necessary. (Keep the cable as short as possible.)

NOTE) When using a photodiode whose cathode is internally connected to its metal package, secure the photodiode with an insulating material when shielding. Otherwise, signal current cannot be drawn when the photodiode package is grounded.

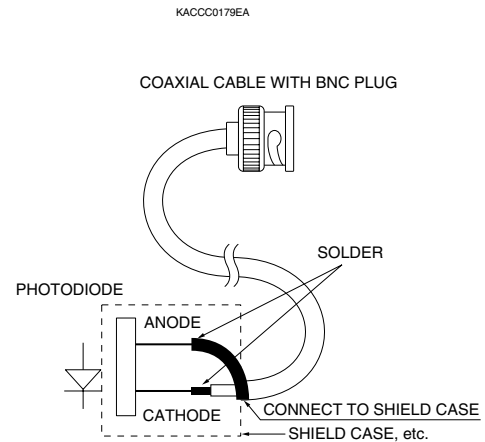

KACCC0180EA

■ Dimensional outline (unit: mm)

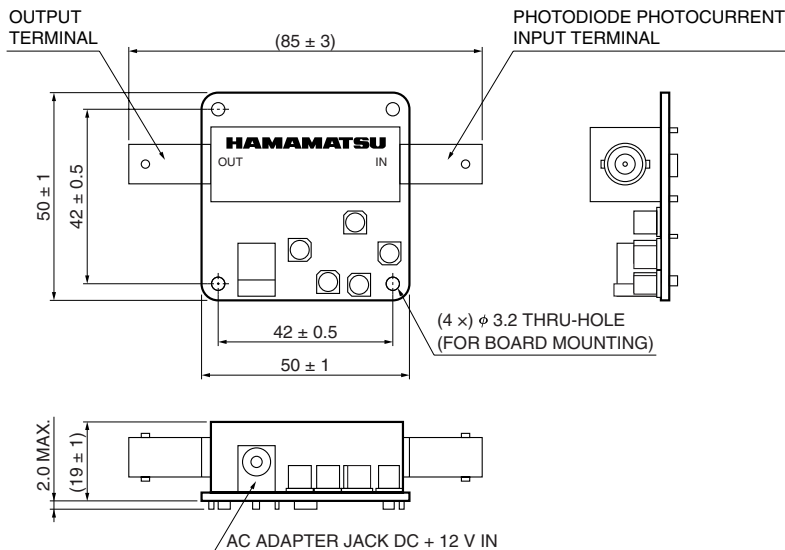

KACCA0116EA

■ Accessory

AC adapter

HAMAMATSU

Information furnished by HAMAMATSU is believed to be reliable. However, no responsibility is assumed for possible inaccuracies or omissions. Specifications are subject to change without notice. No patent rights are granted to any of the circuits described herein. ©2002 Hamamatsu Photonics K.K.

HAMAMATSU PHOTONICS K.K., Solid State Division

1126-1 Ichino-cho, Hamamatsu City, 435-8558 Japan, Telephone: (81) 053-434-3311, Fax: (81) 053-434-5184, <http://www.hamamatsu.com>

U.S.A.: Hamamatsu Corporation: 360 Foothill Road, P.O.Box 6910, Bridgewater, N.J. 08807-0910, U.S.A., Telephone: (1) 908-231-0960, Fax: (1) 908-231-1218

Germany: Hamamatsu Photonics Deutschland GmbH: Arzbergerstr. 10, D-82211 Herrsching am Ammersee, Germany, Telephone: (49) 08152-3750, Fax: (49) 08152-2658

France: Hamamatsu Photonics France S.A.R.L.: 8, Rue du Saule Trapu, Parc du Moulin de Massy, 91882 Massy Cedex, France, Telephone: 33-(1) 69 53 71 00, Fax: 33-(1) 69 53 71 10

United Kingdom: Hamamatsu Photonics UK Limited: 2 Howard Court, 10 Tewin Road, Welwyn Garden City, Hertfordshire AL7 1BW, United Kingdom, Telephone: (44) 1707-294888, Fax: (44) 1707-325777

North Europe: Hamamatsu Photonics Norden AB: Smidesvägen 12, SE-171 41 Solna, Sweden, Telephone: (46) 8-509-031-00, Fax: (46) 8-509-031-01

Italy: Hamamatsu Photonics Italia S.R.L.: Strada della Moia, 1/E, 20020 Arese, (Milano), Italy, Telephone: (39) 02-935-81-733, Fax: (39) 02-935-81-741