

NEW

IMAGE SENSOR

CCD multichannel detector head C7027

Designed for front-illuminated CCD area image sensor

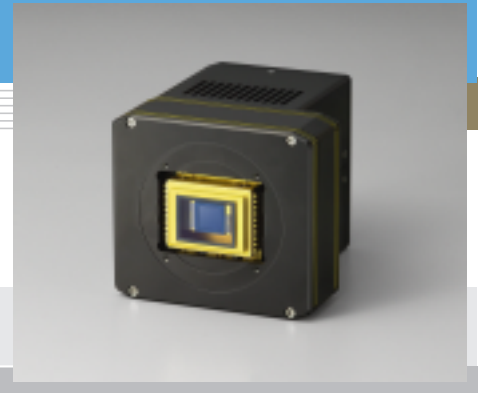

C7027 is a multichannel detector head for use with front-illuminated FFT-CCD area image sensors (S7017/S7847 series) that offer high UV sensitivity and quantum efficiency. C7027 incorporates a low-noise driver/amplifier circuit that provides reliable operation from simple external signals. C7027 includes a highly stable temperature controller that cools the sensor to a preset temperature level ($T_s = -50\text{ }^\circ\text{C}$) as soon as the power is turned on. If the cooler fails and causes internal circuitry to overheat, the built-in protection circuit automatically turns off the power to the thermoelectric cooler. Despite its compact size, the housing configuration is designed for good heat dissipation, and threaded mounting holes on the front panel allow connections to other devices such as monochrometers.

Features

- Designed for front-illuminated CCD area image sensor
- Line binning operation/area scanning operation *1
- Driver/amplifier circuit for low noise CCD operation
- Highly stable temperature controller
Cooling temperature: $-50 \pm 0.05\text{ }^\circ\text{C}$
($T_a = 10$ to $35\text{ }^\circ\text{C}$)
- Simple signal input operation
- Compact configuration

Applications

- Fluorescence spectroscopy
- Raman spectroscopy
- Other low-light-level detection

The table below shows CCD area image sensors applicable for C7027

Since C7027 does not include a CCD area image sensor, so select the desired sensor and order it separately.

CCD area image sensor			
Type No.	Number of pixels	Number of active pixels	Active area [mm (H) × mm (V)]
S7017-1007	1044 × 128	1024 × 124	24.576 × 2.976
S7017-1008	1044 × 256	1024 × 252	24.576 × 6.048
S7847-1007 (High IR sensitivity type)	1044 × 128	1024 × 124	24.576 × 2.976
S7847-1008 (High IR sensitivity type)	1044 × 256	1024 × 252	24.576 × 6.048

*1: The FFT-CCD was originally designed as a two-dimensional image sensor. However, it can be operated like a linear image sensor having a large active area by transferring all the pixel signals in the vertical direction to the horizontal register (this is referred to as line binning).

Note: C7027 can be operated from C7557 multichannel detector head controller, but cannot be cooled below $-50\text{ }^\circ\text{C}$ due to cooling capacity limitation.

**SOLID
STATE** DIVISION

■ Absolute maximum ratings

Parameter	Symbol	Min.	Typ.	Max.	Unit
Supply voltage (for digital circuitry)	VD1	-0.5	-	+7	V
Supply voltage (for analog circuitry)	VA1+	-	-	+18	
	VA1-	-	-	-18	
Supply voltage	VA2	-	-	+30	
	VD2	-	-	+7	
	Vp	-	-	+7	
	VF	-	-	+14	
Digital input voltage	-	-	-	VD (1, 2)	
Operating temperature	Topr	+10	-	+35	°C
Storage temperature	Tstg	0	-	+70	

■ Electrical characteristics

(Ta=25 °C, VD1=+5 V, VA1+=+15 V, VA1=-15 V, VA2=+24 V, VD2=+5 V, Vp=+5 V, VF=+12 V, unless otherwise noted)

Parameter	Symbol	Min.	Typ.	Max.	Unit	
Digital input	High level	V _{IH}	+2.0	-	+5.0	V
	Low level	V _{IL}	-0.5	-	+0.8	V
CLK frequency	f _{CLK}	-	-	1	MHz	
Data video readout frequency	f _v	-	-	f _{CLK} /4	Hz	
Start pulse width	t _{st}	1/f _{CLK}	-	-	s	
Digital output	High level (I _o =-6 mA)	V _{IH}	+2.0	-	-	V
	Low level (I _o =+6 mA)	V _{IL}	-	-	+0.8	V
Power supply operating conditions						
Voltage	Digital circuitry	VD	+4.75	+5.0	+5.25	V
	Analog circuitry	VA1+	+14.5	+15.0	+15.5	V
		VA1-	-14.5	-15.0	-15.5	V
		VA2	+23.5	+24.0	+24.5	V
	Other	VD2	+4.75	+5.0	+5.25	V
		Vp	+4.75	+5.0	+5.25	V
VF		+11.75	+12.0	+12.75	V	
Current	VD1 (+5 VDC)	-	-	-	+200	mA
	VA1+ (+15 VDC)	-	-	-	+100	mA
	VA1- (-15 VDC)	-	-	-	-100	mA
	VA2 (+24 VDC)	-	-	-	+30	mA
	Vp (+6 VDC) Ta=25 °C	-	-	+2.5	+4.0	A
	VF (+12 VDC)	-	-	+100	-	mA

■ Electrical and optical characteristics

(Ta=25 °C, Ts= -50 °C, VD1=+5 V, VA1+=+15 V, VA1=-15 V, VA2=+24 V, VD2=+6 V, Vp=+6 V, VF=+12 V)

Parameter	Symbol	Min.	Typ.	Max.	Unit
Spectral response range	λ	-	200 to 1100	-	nm
Full well capacity	Vertical	-	300,000	-	e ⁻
	Horizontal	-	600,000	-	
Conversion gain *2	Sv	-	15	-	μV/e ⁻
Dark current	S7017	-	0.03	0.1	e ⁻ /pixel/s
	S7847	-	0.3	1	
Readout noise	Nr	-	15	45	e ⁻ rms
Dynamic range	DR	-	75,000	-	-
Photo response non-uniformity *3	PRNU	-	-	±10	%

*2: Including the circuit gain.

*3: Measured at 50 % of the full well capacity.

■ Specifications for temperature controller

(Ta=25 °C, Ts= -50 °C, VD1=+5 V, VA1+=+15 V, VA1=- -15 V, VA2=+24 V, VD2=+6 V, Vp=+6 V, Vf=+12 V)

Parameter *4	Symbol	Min.	Typ.	Max.	Unit
Cooling temperature	Ts	-51	-50	-49	°C
Temperature control range	ΔTs	-0.05	-	+0.05	°C
Power dissipation of TE-cooler element	Pp	-	-	15	W
Cool down time to reset temperature	to	-	-	5	min.
Setting temperature for overheat protection *5	To	-	+45	-	°C

*4: Other functions include error display, automatic power off, and detection of electrical opens and shorts by the thermosensor.

*5: Temperature at back side of housing (between housing and fan)

■ Spectral response (without window)

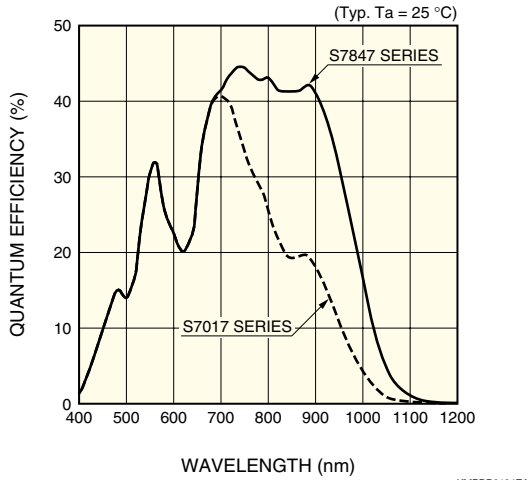

■ Device structure, line output format

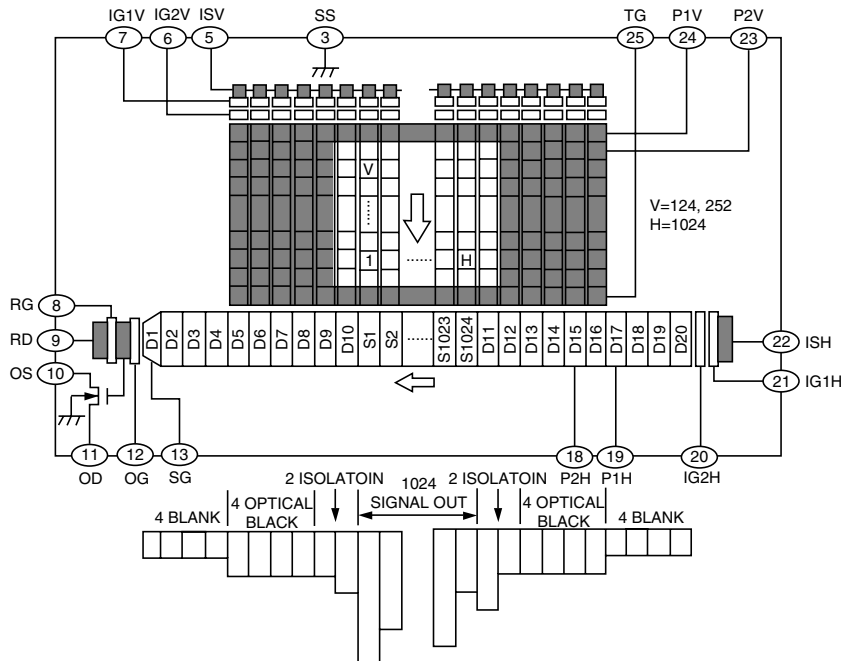

Pixel format

Left ← Horizontal Direction → Right						
Blank	Optical Black	Isolation	Effective	Isolation	Optical Black	Blank
4	4	2	1024	2	4	4

Top ← Vertical Direction → Bottom		
Isolation	Effective	Isolation
2	124 or 252	2

■ Block diagram

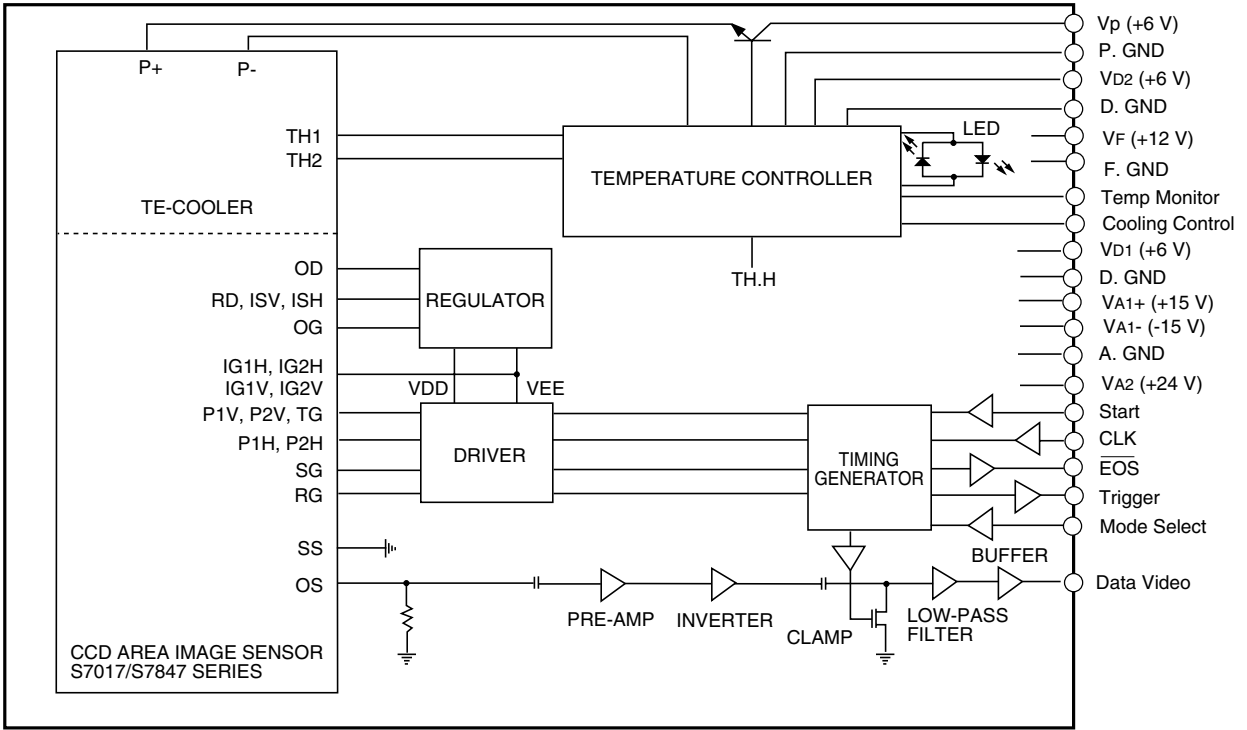

KACCC0159EA

■ Timing chart of line binning operation

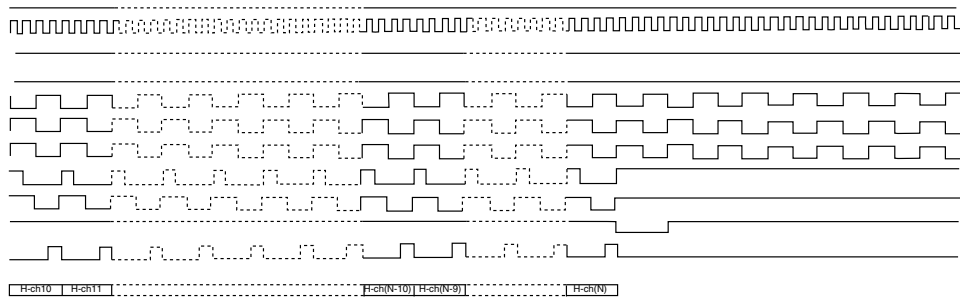
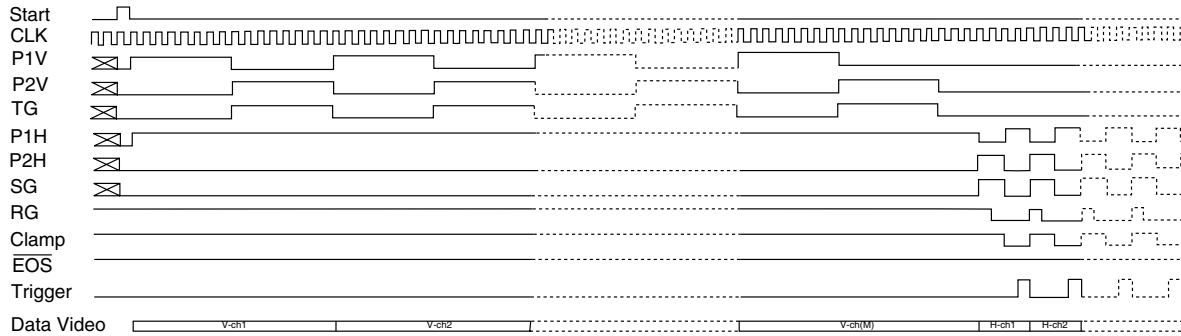

M=128, 256 N=1044
 V-ch1--V-ch4, V-ch (M-1)--V-ch (M): ISOLATION PIXELS
 H-ch1--H-ch4, H-ch (N-3)--H-ch (N): BLANK PIXELS
 H-ch5--H-ch8, H-ch (N-7)--H-ch (N-4): ISOLATION PIXELS

KACCC0160EA

■ Timing chart of area scanning operation

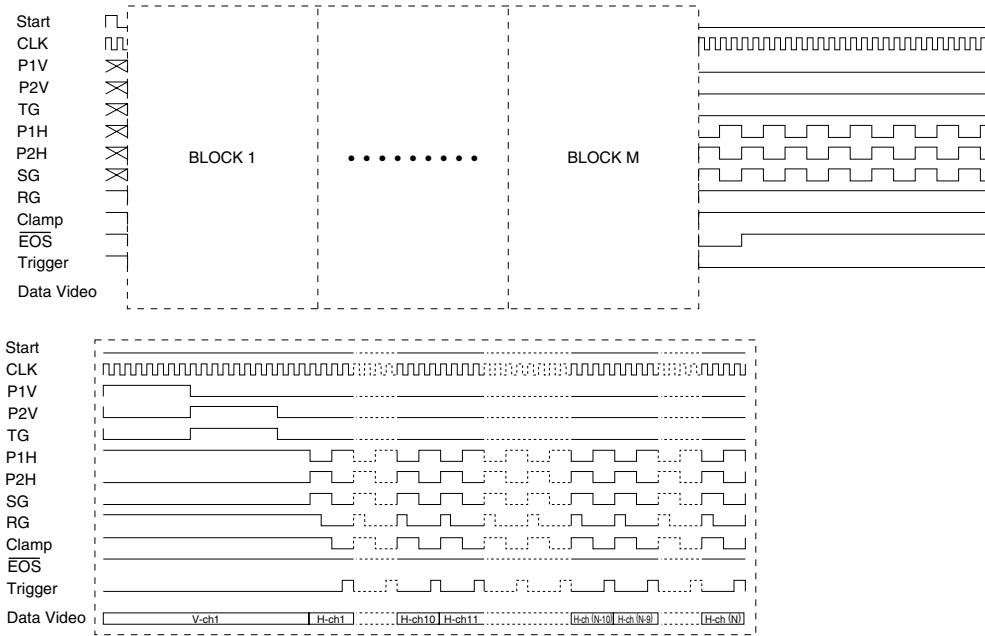

KACCC0161EA

■ Pin connection of "SIGNAL I/O" connector

15-pin D-sub connector

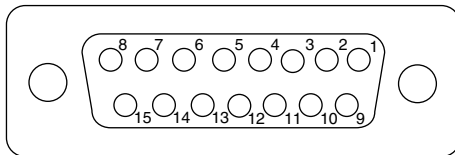

KACCC0069EA

Pin No.	Terminal name	Description
1	Mode select	Digital input signal used to select between the line binning operation and area scanning operation. HCMOS compatible. High level or left open: line binning operation Low level: area scanning operation
2	Data video	Analog video output. Positive polarity
3	VA1+ (+15 V)	Analog power supply
4	VA1- (-15 V)	Analog power supply
5	VD1 (+5 V)	Digital power supply
6	Start	Digital input signal for initializing the circuit. HCMOS compatible. Positive logic. The interval of the Start pulses determines the integration time of the CCD image sensor.
7	CLK	Digital input signal for operating the circuit. HCMOS compatible. Rising edge operation.
8	EOS	Digital input signal for indicating end-of-scan of the image sensor. HCMOS compatible. Negative logic.
9	A. GND	Analog ground
10	A. GND	Analog ground
11	VA2 (+24 V)	Analog power supply
12	D. GND	Digital ground
13	D. GND	Digital ground
14	D. GND	Digital ground
15	Trigger	Digital output signal for A/D conversion. HCMOS compatible. Positive logic.

■ Pin connection of "TE CONTROL I/O" connector

9-pin D-sub connector

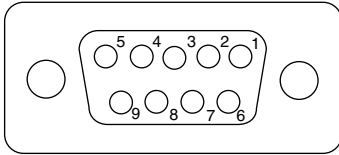

KACCC0075EA

Pin No.	Terminal name	Description
1	V _{D2} (+6 V)	Digital power supply
2	Temp monitor	Analog output signal of the temperature of the CCD image sensor
3	Cooling control	Digital input signal for starting to cool down. HCMOS compatible. High level or left open: cooling Low level: stand-by
4	V _p (+6 V)	Power supply for the thermoelectric cooler in the CCD image sensor. (Please use AWG 18 wire)
5	V _F (+12 V)	Power supply for cooling fan
6	D. GND	Ground
7	D. GND	Ground
8	P. GND	Power supply return of the thermoelectric cooler mounted in the CCD image sensor. (Please use AWG 18 wire)
9	F. GND	Power supply return for cooling fan

Available for using same power supply (+5 V) for "+V_{D2}" and "+V_p".

■ Dimensional outline (unit: mm)

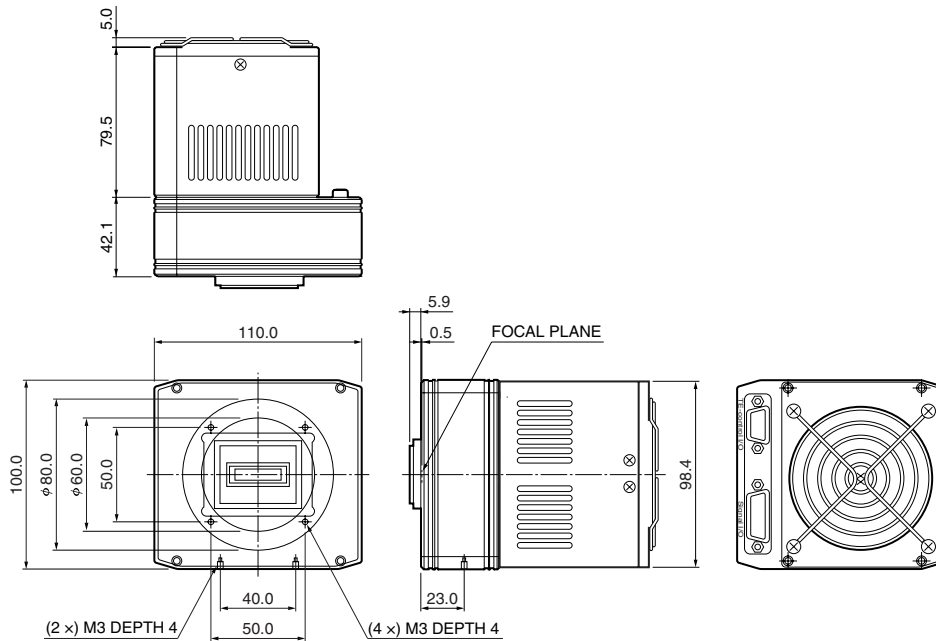

KACCA0109EA

■ Connection example

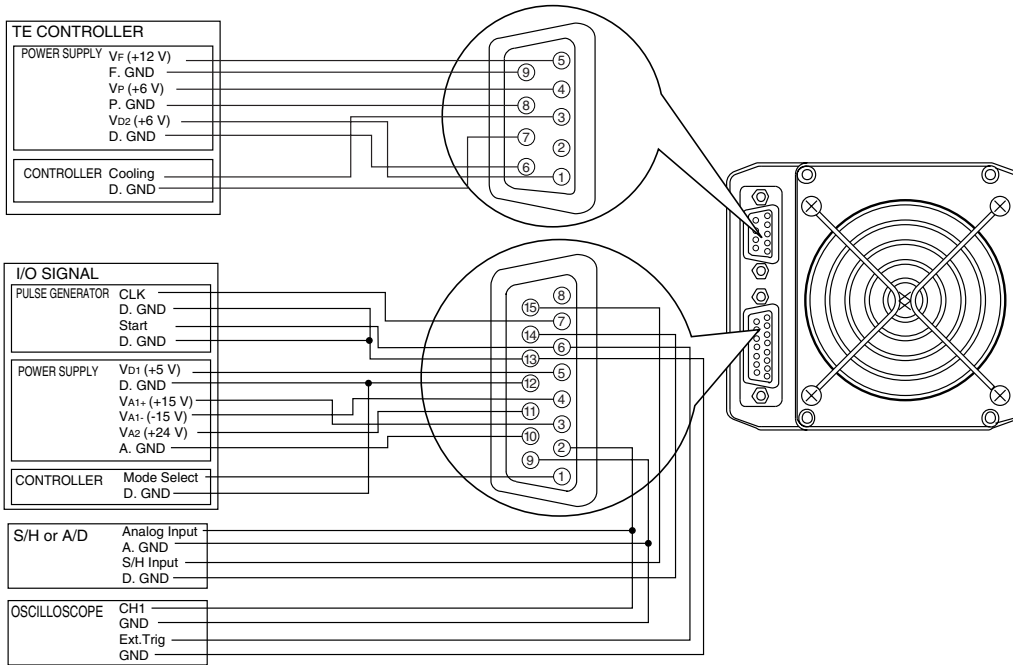

KACCC0162EA