



# BTM98-8AAm

DATA SHEET

22 Mar 2013

Version 1.0

SHENZHEN TTK TECHNOLOGY CO., LTD.

Copyright © TTK Technologies. all rights reserved.

Shenzhen TTK Technology CO.,LTD

TEL: 0755-89484041 FAX: 0755-89484040

TABLE OF CONTENTS

1.0 Block Diagram..... 5

2.0 Electrical Characteristics ..... 6

3.0 Device Terminal Functions..... 8

4.0 Example Application Schematic..... 11

5.0 Package Dimensions..... 11

6.0 Layout Guidelines..... 14

7.0 Contact Information..... 15

**DESCRIPTION:**

BTM98-8AAm is the latest generation of Bluetooth Module. It provides highest level of integration

With integrated 2.4GHz radio, DSP, battery

Charger, and antenna ready. Mono applications.

BTM98-8AAm is also ready to support the latest

Bluetooth 4.0 standard and support for secure

Simple pairing.

**FEATURES:**

- Plug n' Play Bluetooth Solution for mono Audio Solutions
- Integrated DSP, and Battery Charger
- Integrated Antenna
- Bluetooth 4.0 Compliant
- Class II Range up to 10 Meters
- Temperature range from -30C to +85C
- Supported Bluetooth Profiles: A2DP, AVRCP, HFP, HSP
- Near-end audio enhancements(noise suppression and AEQ)
- High-quality Audio 95dB SNR on DAC Playback
- mSBC, decoder support
- USB 2.0 (full-speed)

**APPLICATIONS:**

- High quality wireless headsets
- Wireless mono headsets
- Wireless speakers
- Hands-free car kits



### 1.0 Block Diagram

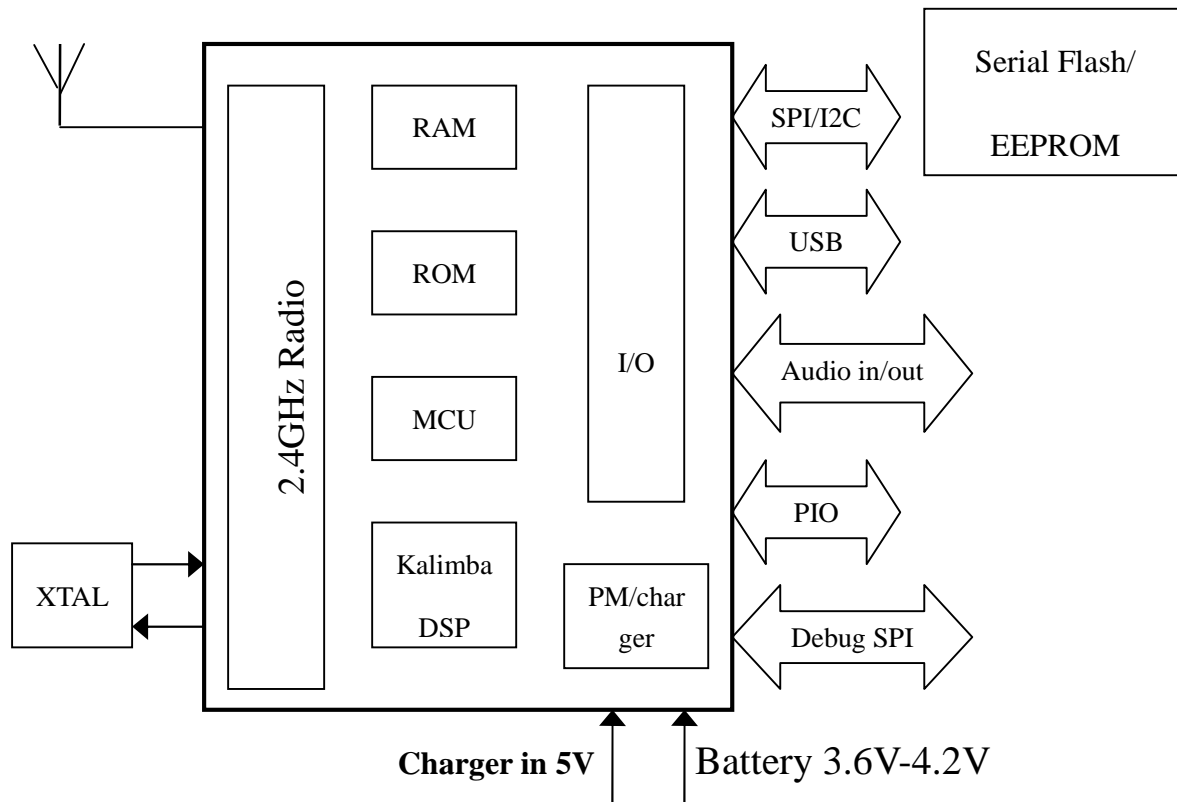

**Figure 1:** Block diagram of BTM98-8AA

## 2.0 Electrical Characteristics

### Recommended operating conditions

	Min	Typ	Max	Unit
Operating temperature	-20	20	70	°C
VDD_BAT	3.0	3.8	4.2	V
VDD_CHG	4.5	5	6.5	V
VDD_IO	1.7	1.8	1.95	V

**Table 1:**Recommended operating conditions

### Battery charger

Charger Mode(BAT_P rising to 4.2V)		Min	Typ	Max	Unit
Supply current(a)		--	4.5	6	mA
Battery trickle charge current(b)		--	4	--	mA
Maximum battery fast charge current (I-CTRL = 15)(c) (d)	Headroom(e) > 0.7V	--	200	--	mA
	Headroom = 0.3V	--	150	--	mA
Minimum battery fast charge current (I-CTRL = 0)(c) (d)	Headroom > 0.7V	--	40	--	mA
	Headroom = 0.3V	--	35	--	mA

Trickle charge voltage threshold	--	2.9	--	V
Float voltage (with correct trim value set), VFLOAT (f)	4.10	4.15	4.2	V
Float voltage trim step size(f)	--	50	--	mV
Battery charge termination current, % of fast charge current	5	10	20	%

(a) Current into VDD\_CHG does not include current delivered to battery (IVDD\_CHG - IBAT\_P)

(b) BAT\_P < trickle charge voltage threshold

(c) Charge current can be set in 16 equally spaced steps

(d) Trickle charge threshold < BAT\_P < Float voltage

(e) Where headroom = VDD\_CHG - BAT\_P

(f) Float voltage can be adjusted in 15 steps. Trim setting is determined in production test and must be loaded into the battery charger by firmware during boot-up sequence

**Table 2:** Battery charger characteristics

## Reset

	Min	Typ	Max	Unit
$V_{TH,res}$ threshold voltage	0.65	0.85	1.50	V
$R_{IRES}$ input resistance	--	220	--	K $\Omega$
$C_{IRES}$ input capacitance	--	220	--	nF

**Table 3:** Reset terminal characteristics

Shenzhen TTK Technology CO.,LTD  
 TEL: 0755-89484041 FAX: 0755-89484040

The RESET pin is an active low reset and is internally filtered using the internal low frequency clock oscillator. A reset will be performed between 1.5 and 4.0ms following RESET being active. It is recommended that RESET be applied for a period greater than 5ms. BTM98-8AAm has an internal reset circuitry, when BTM98-8AAm input 5V charging voltage, Module reset once.

The capacitor discharges through 220 k resistor, which eventually deactivates the reset. Time constant of the RC circuitry is set in a way that the supply voltage is safely stabilized before the reset deactivates.

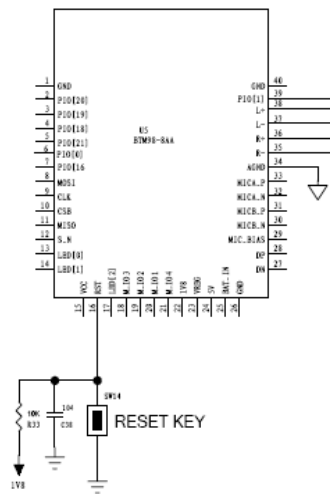
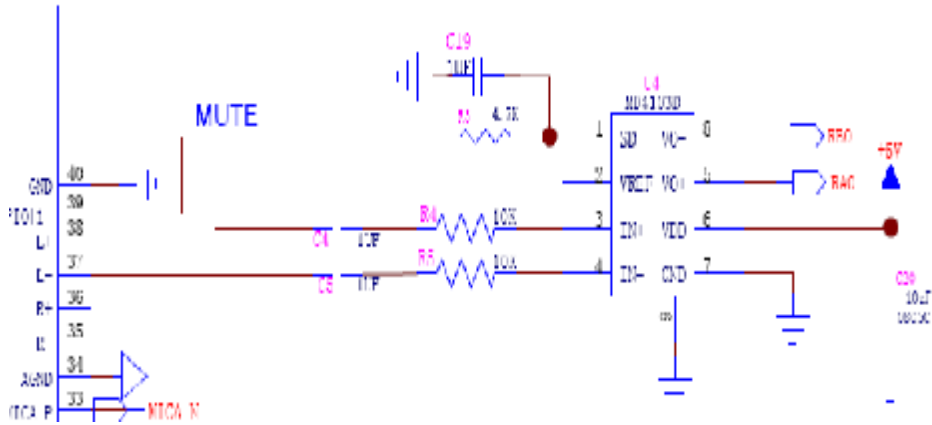

**Figure 2:** BTM98-8AAm reset circuitry



### MUTE

BTM98-8AAm can output a high level to control the amplifier mute. When bluetooth normal working, Module output high level to control the amplifier open. Standby, Module output low level to control the amplifier off.



**Figure 3:** BTM98-8AAm Mute control circuitry

.3.Device Terminal Functions:

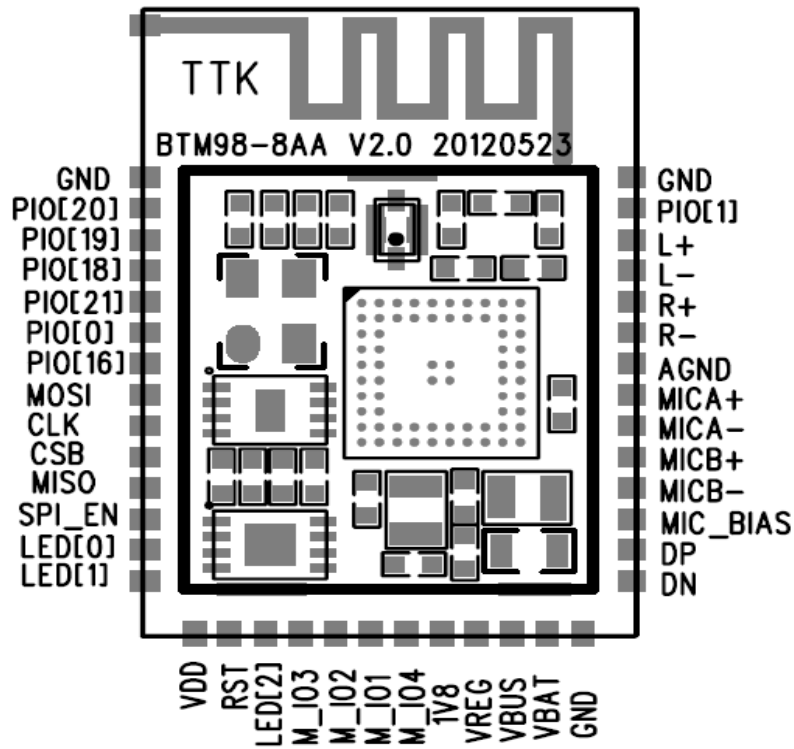

Lead	name	Function	Description
1	GND	GND	Ground
2	PIO[20]	PIO port	Programmable input/output line
3	PIO[19]	PIO port	Programmable input/output line
4	PIO[18]	PIO port	Programmable input/output line
5	PIO[21]	PIO port	Programmable input/output line
6	PIO[0]	PIO port	Programmable input/output line
7	PIO[16]	PIO port	Programmable input/output line
8	MOSI	SPI interface	SPI data input
9	CLK	SPI interface	SPI Clock
10	CSB	SPI interface	Chip select for SPI
11	MISO	SPI interface	SPI data output
12	SPI N	NC	NC

Shenzhen TTK Technology CO.,LTD  
 TEL: 0755-89484041 FAX: 0755-89484040

13	LED[0]	Status	LED driver
14	LED[1]	Status	LED driver
15	VDD	VDD	NC
16	RST	Reset	Logic low reset
17	LED[2]	Status	LED driver
18	M IO[3]	M IO[3]	IO
19	M IO[2]	M IO[2]	IO
20	M IO[1]	M IO[1]	IO
21	M IO[4]	M IO[4]	IO
22	1V8	1.8V POWER	Positive supply for 1.8V regulated output
23	VREG	POWER ON/OFF	Module power on/off active high
24	5V	5V-charger	Lithium ion/polymer battery charger input
25	VBAT	Power Input	Lithium ion/polymer battery positive
26	GND	GND	Ground
27	DN	DN	USB Data negative
28	DP	DP	USB Data positive
29	MIC BIA	MIC power	Microphone bias
30	MICB N	MICB N	MIC input, channel B negative
31	MICB P	MICB P	MIC input, channel B positive
32	MICA N	MICA N	MIC input, channel A negative
33	MICA P	MICA P	MIC input, channel A positive
34	AGND	AGND	Analogue ground
35	R-	R-	Speaker output, channel R negative
36	R+	R+	Speaker output, channel R positive
37	L-	L-	Speaker output, channel L negative
38	L+	L+	Speaker output, channel L positive
39	PIO[1]	MUTE	Amplifier mute PIN
40	GND	GND	Ground

Note: channel R is not available

## **4.0 Example Application Schematic**

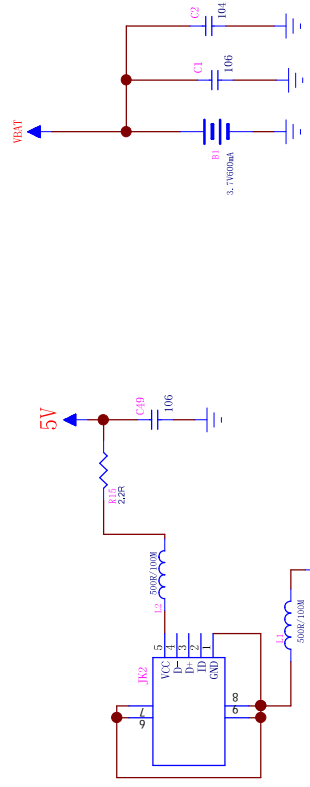
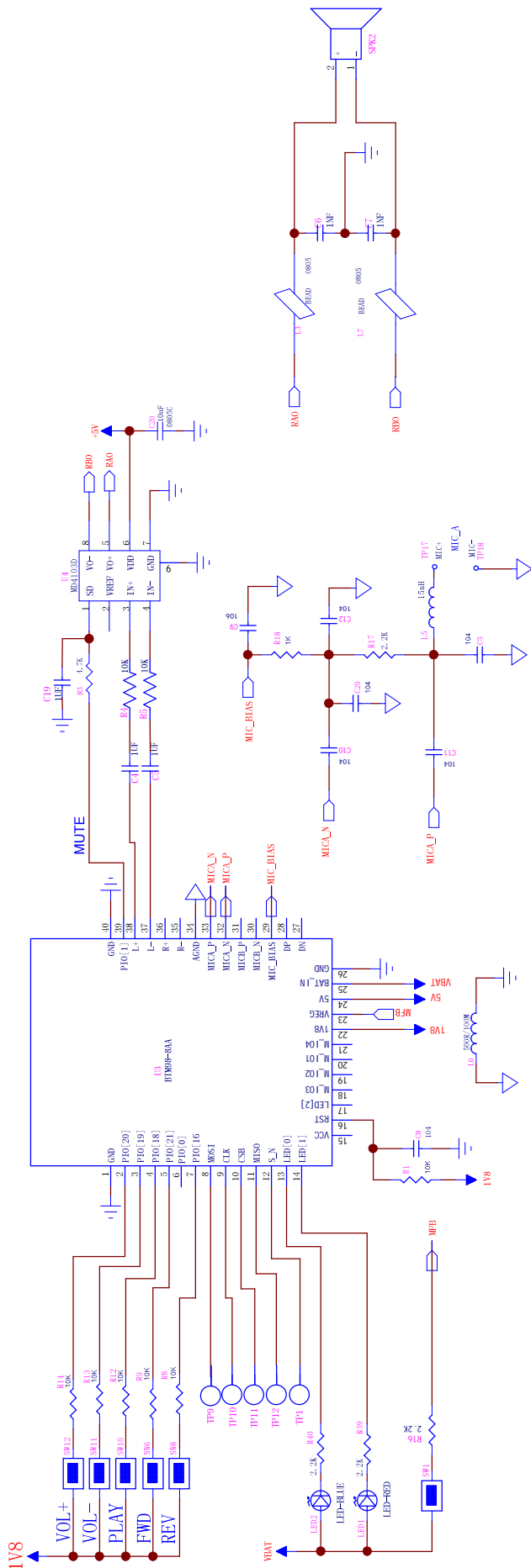

<b>ELECTRONIC CO., LTD</b>	
TITLE:	PRODUCT NO:
DRAWN BY:	LY NO:
CHECKED BY:	DATA: 2011.07.15
APPROVED BY:	DATA:
	SCALE: 1/1
	SIZE: A4
	REV NO: 0A
	SHEET: 1/1

### 5.0 Package Dimensions

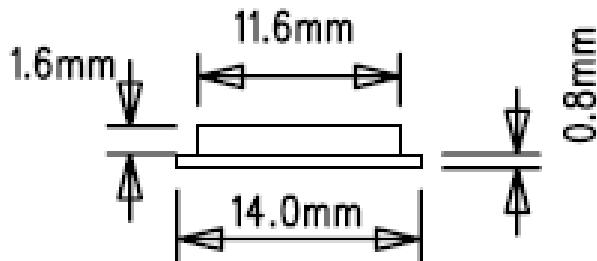
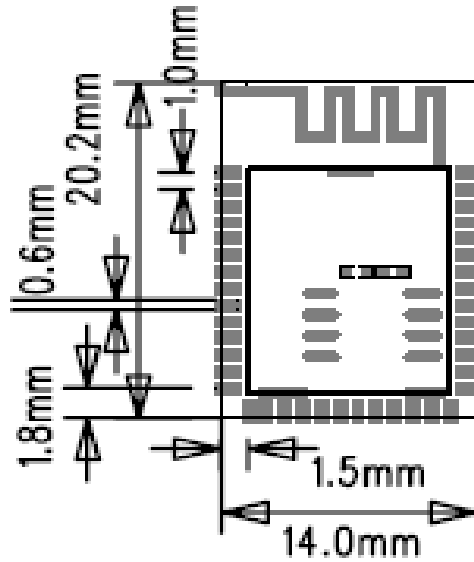

Unit: mm

Shenzhen TTK Technology CO.,LTD  
TEL: 0755-89484041 FAX: 0755-89484040

## 6.0 Layout Guidelines

### 6.0.1 Audio Layout

Route audio lines as differential pairs. The positive and negative signals should run parallel and close to each other until they are converted to single-ended signals. Use dedicated audio ground plane for entire audio section.

### 6.0.2 Antenna Design

Do not place GND plane or any metal directly under the antenna of BTM-68D. To avoid any excess parasitic capacitance in the antenna feed line caused by the RF test pin on the bottom side of the module, the area underneath the RF test pin should also be left free from copper. Any metal in close proximity of the antenna will have an effect on the antenna performance. Thus any metal should be placed as far from the antenna as possible. The module should be placed to an edge of the PCB.

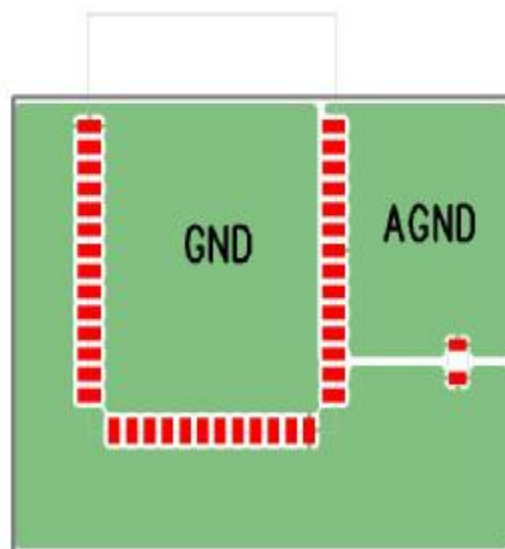

## 7.0 Contact Information

Sales : [ttk@szttk.com](mailto:ttk@szttk.com)

Technical Support: [zuogq@szttk.com](mailto:zuogq@szttk.com) ; [zhangl@szttk.com](mailto:zhangl@szttk.com)

Address: 8th Floor,Southland Building,minzhi hongshan ,  
Mei long Road, long hua Town, Bao'an District,shenzhen

Website: [WWW.szttk.com](http://WWW.szttk.com)

Shenzhen TTK Technology CO.,LTD  
TEL: 0755-89484041 FAX: 0755-89484040