



BDX67 – A – B – C

NPN SILICON DARLINGTON POWER TRANSISTOR

The BDX67, BDX67A, BDX67B and BDX67C are mounted in TO-3 metal package.
 High current power darlington designed for power amplification and switching applications.
 The complementary PNP are BDX66, BDX66A, BDX66B, BDX66C.
 Compliance to RoHS.

ABSOLUTE MAXIMUM RATINGS

Symbol	Ratings		Value	Unit	
V_{CEO}	Collector-Emitter Voltage	BDX67	60	V	
		BDX67A	80		
		BDX67B	100		
		BDX67C	120		
V_{CBO}	Collector-Base Voltage	BDX67	80	V	
		BDX67A	100		
		BDX67B	120		
		BDX67C	140		
V_{EBO}	Emitter-Base Voltage	BDX67	5.0	V	
		BDX67A			
		BDX67B			
		BDX67C			
I_C	Collector Current	$I_{C(RMS)}$	BDX67	16	A
			BDX67A		
			BDX67B		
			BDX67C		
		I_{CM}	BDX67	20	
			BDX67A		
			BDX67B		
			BDX67C		
I_B	Base Current	BDX67	0.25	A	
		BDX67A			
		BDX67B			
		BDX67C			
P_T	Power Dissipation	@ $T_C = 25^\circ$	BDX67	150	Watts W/°C
			BDX67A		
			BDX67B		
			BDX67C		
T_J	Junction Temperature				
T_S	Storage Temperature		-55 to +200		°C



BDX67 – A – B – C

THERMAL CHARACTERISTICS

Symbol	Ratings	Value	Unit	
R_{thJ-C}	Thermal Resistance, Junction to Case	BDX67	1.17	°C/W
		BDX67A		
		BDX67B		
		BDX67C		

ELECTRICAL CHARACTERISTICS

TC=25°C unless otherwise noted

Symbol	Ratings	Test Condition(s)	Min	Typ	Max	Unit	
$V_{CEO(SUS)}$	Collector-Emitter Breakdown Voltage (*)	$I_C=0.1\text{ A}$, $L=25\text{mH}$	BDX67	60	-	-	V
			BDX67A	80	-	-	
			BDX67B	100	-	-	
			BDX67C	120	-	-	
I_{CEO}	Collector Cutoff Current	$V_{CE}=30\text{ V}$	BDX67	-	-	3	mA
		$V_{CE}=40\text{ V}$	BDX67A	-	-		
		$V_{CE}=50\text{ V}$	BDX67B	-	-		
		$V_{CE}=60\text{ V}$	BDX67C	-	-		
I_{EBO}	Emitter Cutoff Current	$V_{BE}=5\text{ V}$	BDX67	-	-	5.0	mA
			BDX67A				
			BDX67B				
			BDX67C				
I_{CBO}	Collector-Base Cutoff Current	$T_{CASE}=25^\circ\text{C}$ $V_{CB}=60\text{ V}$	BDX67	-	-	1	mA
		$T_{CASE}=200^\circ\text{C}$ $V_{CB}=40\text{ V}$				5	
		$T_{CASE}=25^\circ\text{C}$ $V_{CB}=80\text{ V}$	BDX67A	-	-	1	
		$T_{CASE}=200^\circ\text{C}$ $V_{CB}=50\text{ V}$				5	

BDX67 – A – B – C

ELECTRICAL CHARACTERISTICS

TC=25°C unless otherwise noted

Symbol	Ratings	Test Condition(s)	Min	Typ	Max	Unit	
I_{CBO}	Collector-Base Cutoff Current	$T_{CASE}=25^{\circ}C$ $V_{CB}=100 V$	BDX67B	-	-	1	mA
		$T_{CASE}=200^{\circ}C$ $V_{CB}=60 V$		-	-	5	
		$T_{CASE}=25^{\circ}C$ $V_{CB}=120 V$	BDX67C	-	-	1	
		$T_{CASE}=200^{\circ}C$ $V_{CB}=70 V$		-	-	5	
h_{FE}	Dc Current Gain	$V_{CE}=3 V, I_C=1 A$	-	5200	-	-	
		$V_{CE}=3 V, I_C=10 A$	1000	-	-		
		$V_{CE}=3 V, I_C=16 A$	-	4000	-		
$V_{CE(SAT)}$	Collector-Emitter Saturation Voltage (*)	$I_C=10 A$ $I_B=40 mA$	BDX67	-	-	2	V
			BDX67A				
			BDX67B				
			BDX67C				
V_{BE}	Base-Emitter Voltage(1&2)	$V_{CE}=3 V$ $I_C=10 A$	BDX67	-	-	2,5	V
			BDX67A				
			BDX67B				
			BDX67C				
V_F	Diode Forward Voltage	$I_F=10 A$	BDX67	-	2,5	-	V
			BDX67A				
			BDX67B				
			BDX67C				
C_c	Collector Capacitance	$I_E=0 A$ $V_{CB}=10V$	BDX67	-	300	-	pF
			BDX67A				
			BDX67B				
			BDX67C				
t_{on}	Switching Characteristics	$V_{CC}=12V$ $I_C=-10 A$ $I_{B1}=-I_{B2}=0.04 A$	BDX67	-	1	-	μs
			BDX67A				
			BDX67B				
			BDX67C				
t_{off}			BDX67	-	3.5	-	
			BDX67A				
			BDX67B				
			BDX67C				
f_{hfe}	Small Signal Current Gain	$V_{CE}=-3 V$ $I_C=-5 A$	BDX67	-	50	-	kHz
			BDX67A				
			BDX67B				
			BDX67C				

(*) Pulse Width $\approx 300 \mu s$, Duty Cycle $\angle 2.0\%$

(1) collector-Emitter voltage limited et $V_{CEci} = V_{rated}$ by an auxiliary circuit

BDX67 – A – B – C

MECHANICAL DATA CASE TO-3

DIMENSIONS (mm)		
	min	max
A	11	13.10
B	0.97	1.15
C	1.5	1.65
D	8.32	8.92
F	19	20
G	10.70	11.1
N	16.50	17.20
P	25	26
R	4	4.09
U	38.50	39.30
V	30	30.30

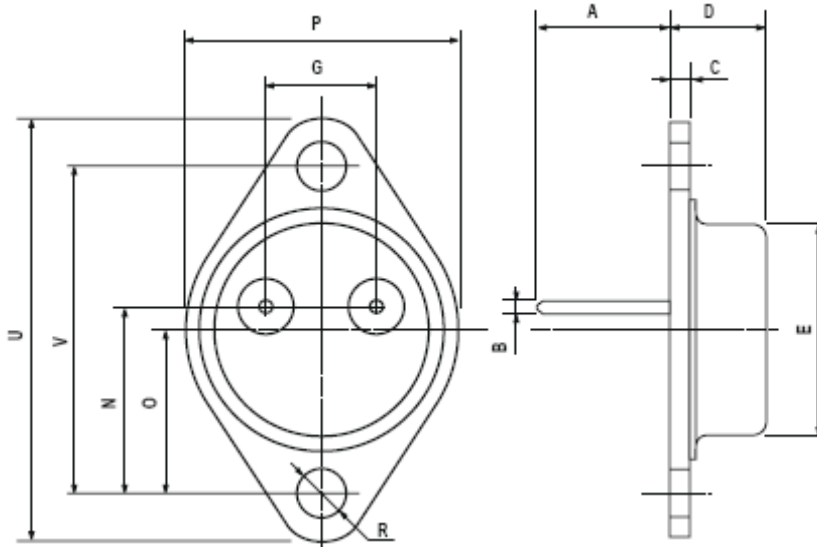

Pin 1 :	Base
Pin 2 :	Emitter
Case :	Collector

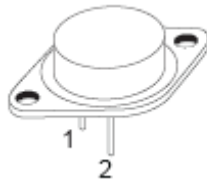

Revised August 2012

Information furnished is believed to be accurate and reliable. However, Comset Semiconductors assumes no responsibility for the consequences of use of such information nor for any infringement of patents or other rights of third parties which may result from its use. Data are subject to change without notice. Comset Semiconductors makes no warranty, representation or guarantee regarding the suitability of its products for any particular purpose, nor does Comset Semiconductors assume any liability arising out of the application or use of any product and specifically disclaims any and all liability, including without limitation consequential or incidental damages. Comset Semiconductors' products are not authorized for use as critical components in life support devices or systems.