

- Structure : Silicon Monolithic Integrated Circuit
- Product Name : Power Driver For CD/DVD Players
- Device Name : BD8201FM
- Externals dimensional drawing : Figure 1
- POWER DISSIPATION : Figure 2
- BLOCK DIAGRAM : Figure 3
- Applied circuit chart : Figure 4
- Features :
 - It is 4ch driver IC of BTL driver 3 ch and Loading driver 1 ch.
 - Loading driver is high D range type of MOS Output
 - With Loading driver Output voltage setting terminal.
 - With MUTE SW.
 - A built-in thermal shutdown circuit is installed.
 - Built in Power-supply voltage descent Mute.
 - BIAS Voltage descent Mute.
 - HSOP-M28 Package

ABSOLUTE MAXIMUM RATINGS (Ta=25)

Parameter	Symbol	Limits	Unit
Power Supply Voltage	Vcc	15	V
Power Dissipation	Pd	2.2 *	W
Operating Temperature Range	Topr	-40 to +85	
Storage Temperature Range	Tstg	-55 to +150	

*1 When mounted on the glass/epoxy board with the size: 70 mm×70 mm, the thickness: 1.6 mm, and the rate of copper foil occupancy area: 3% or less.
Over Ta=25°C, derating at the rate of 17.6mW/°C.

Range of operation power-supply voltage

Parameter	Symbol	MIN	TYP	MAX	Unit
BTL driver Pre part power-supply voltage	PREVCC	4.5	7.5	14	V
BTL driver CH1 part power-supply voltage	VCC1	4.5	7.5	PREVCC	V
BTL driver CH2,3 part power-supply voltage	VCC23	4.5	5.0	PREVCC	V
Loading driver power-supply voltage	LDVCC	4.5	7.5	14	V

ELECTRIC CHARACTERISTICS

(Unless otherwise noted Ta=25 , PREVCC=LDVCC=VCC1=7.5V, VCC23=5V, BIAS=1.65V, RL=8)

Parameter	Symbol	MIN.	TYP.	MAX.	Unit	Condition
Circuit Current (at no signal) (LDVcc)	ICCLD	-	-	1.5	mA	Under braking
Circuit Current (at no signal) (Vcc1)	ICC1	-	-	1.0	mA	No load applied
Circuit Current (at no signal) (Vcc23)	ICC23	-	-	1.0	mA	No load applied
Circuit Current (at no signal) (PreVcc)	ICCPRE	-	-	25	mA	No load applied
<BTL Driver CH1 ~ CH3>						
Output Offset Voltage	VOFS	-50	0	+50	mV	
Maximum Output Amplitude (CH1)	VOM1	4.7	5.4	-	V	
Maximum Output Amplitude (CH2,3)	VOM23	3.7	4.0	-	V	
Closed circuit voltage gain (CH1)	GVC1	9	12	15	dB	RIN=10K
Closed circuit voltage gain (CH2,3)	GVC2	16	18	20	dB	
Positive and negative voltage gain (CH1 ~ CH3)	GVC	-2.0	0	2.0	dB	
Mute ON Voltage	VMON	GND	-	0.5	V	
Mute · Release voltage	VMOFF	2.0	-	PREVCC	V	
Mute terminal inflow current	IMUTE	-	50	100	μA	VMUTE=3.3V
Bias Terminal Input Current	IBIAS	-	50	100	μA	
<Loading driver block CH4>						
Output Offset Voltage	VOFSL	-35	0	+35	mV	Under braking
Input terminal threshold voltage H	VIH	2.8	-	LDVCC	V	
Input terminal threshold voltage M	VIM	1.2	-	2.1	V	
Input terminal threshold voltage L	VIL	GND	-	0.5	V	
Maximum Output Amplitude	VOMLD	6.7	-	-	V	RL=9
Voltage gain (Loading)	GVL	4.0	6.0	8.0	dB	LDCONT=1V
Positive and negative voltage gain (Loading)	GVL	-2.0	0	2.0	dB	
Input terminal inflow current	IINL	-	30	60	μA	LDIN=3.3V
Terminal LDCONT inflow current	ILDC	-	25	80	μA	LDCONT=3.3V

Not designed for radiation resistance.

OUTLINE DIMENSIONS, SYMBOLS

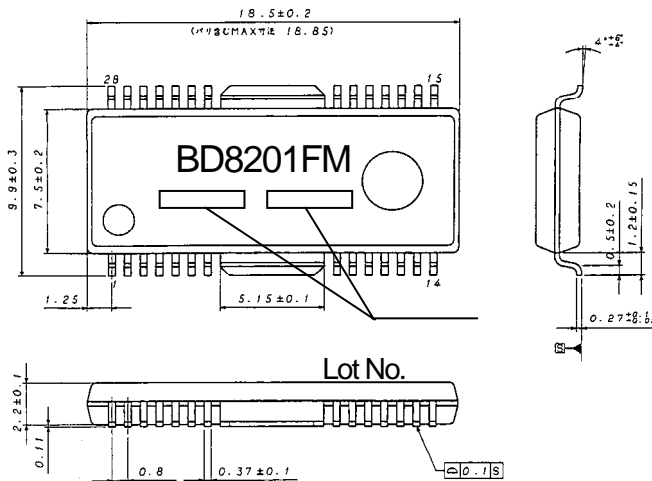

(UNIT: mm)

EX141-6002

APPLICATION CIRCUIT DIAGRAM

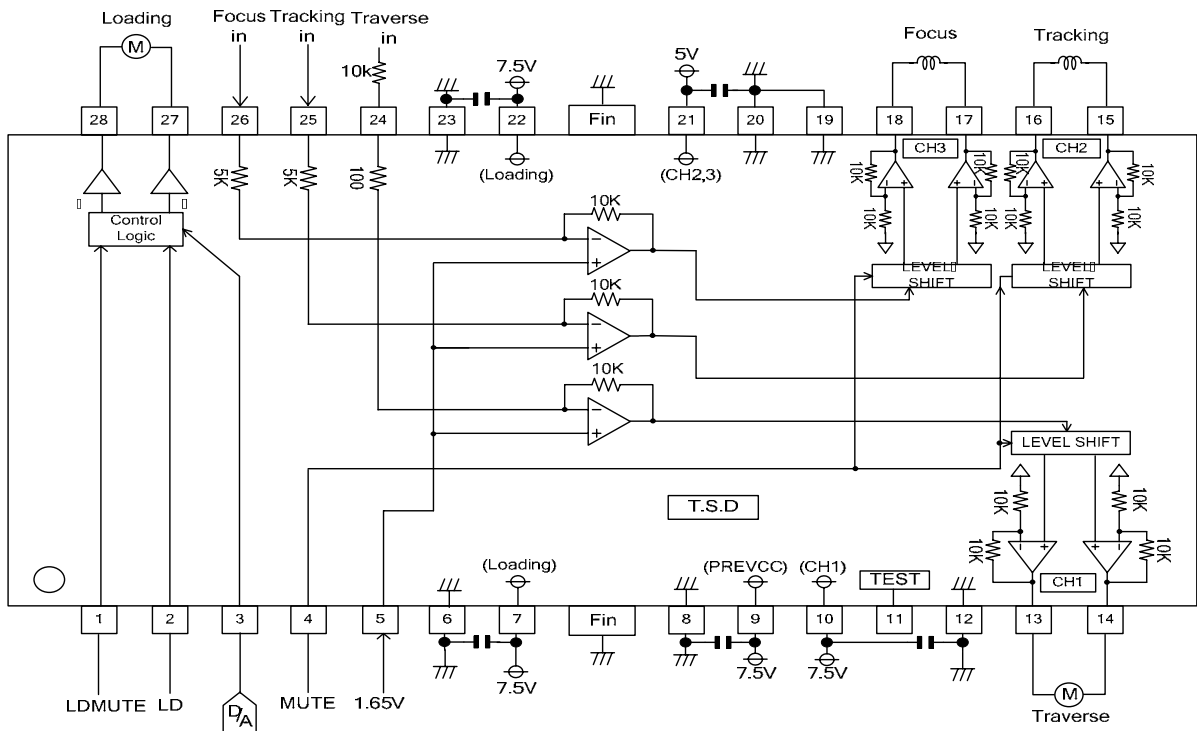

T.S.D : (Thermal shutdown)
Resistance unit : [Ω]

Each terminal explanation

No.	Pin Name	Description	No.	Pin Name	Description
1	LDMUTE	Loading driver MUTE terminal	15	VO2(+)	BTL driver (CH2) positive output terminal
2	LDIN	Loading driver input terminal	16	VO2(-)	BTL driver (CH2) negative output terminal
3	LDCONT	Loading driver Voltage setting terminal	17	VO3(+)	BTL driver (CH3) positive output terminal
4	MUTE	BTL driver MUTE terminal (CH1,CH2,CH3)	18	VO3(-)	BTL driver (CH3) negative output terminal
5	BIAS	Bias input terminal	19	GND	GND terminal (CH2,CH3 POWER part)
6	LDGND	GND terminal (Loading driver part)	20	GND	GND terminal (CH2,CH3 POWER part)
7	LDVCC	VCC terminal (Loading driver part)	21	VCC2,3	Power supply voltage terminal (CH2,CH3 POWER part)
8	PREGND	(BTL driver , Pre part)	22	LDVCC	VCC terminal (Loading driver part)
9	PREVCC	(BTL driver , Pre part)	23	LDGND	GND terminal (Loading driver part)
10	VCC1	VCC terminal (CH1 POWER part)	24	VIN1	CH1 input terminal
11	TEST	Input terminal for TEST mode	25	VIN2	CH2 input terminal
12	GND	GND terminal (CH1 POWER part)	26	VIN3	CH3 input terminal
13	VO1(-)	BTL driver (CH1) negative output terminal	27	LDOUT(-)	Loading driver negative output terminal
14	VO1(+)	BTL driver (CH1) positive output terminal	28	LDOUT(+)	Loading driver positive output

Note: The positive or negative polarity of driver outputs is determined by the input polarity.

Function Description

- MUTE(Pin 4)
BTL driver part (CH1 to CH3) can be switched mode ON/OFF by inputting H lever (above 2.0V) or L level (below 0.5V) to this terminal.
- LDMUTE(Pin 1)
Loading driver part can be switched ON/OFF by inputting H level (above 2.0V) or L level (below 0.5V) to this terminal.
- BIAS dropping mute
Setting BIAS terminal (Pin5) voltage to 0.7 or below (Typ.) will activate mute function for BTL driver part (CH1 to CH3). Set BIAS terminal voltage to 1.1V or above.

4. The following table shows logics for loading driver operation.

INPUT			OUTPUT		FUNCTION
LDMUTE	LDIN	LDCONT	OUT+	OUT-	
L	X	X	Hi Z	Hi Z	High impedance
H	X	<0.7V	Hi Z	Hi Z	High impedance
H	L	>0.7V	L	H	REV mode
H	H	>0.7V	H	L	FWD mode
H	M or Hi Z	>0.7V	L	L	Break mode

Although the output voltage can be changed by the input voltage through the LDCONT terminal (gain 6dB Typ.), it never exceeds the maximum output voltage restricted by the power supply voltage even if applying a voltage much larger than the normal value.

Also, output of loading driver corresponded to LDCONT terminal becomes High-impedance mode by setting LDCONT terminal (3pin) to 0.7V or below.

5. Protection circuit for VCC and GND fault

This IC contains protection circuit for VCC and GND fault to prevent itself from breaking caused by short between BTL driver output pin and VCC (VCC fault) or BTL driver output pin and GND (GND fault).

Make sure output pin should not short to VCC or GND. However in case VCC and GND fault occur, internal circuit prevents IC from breaking by limiting current. (available for only CH1, CH2, CH3)

Protection circuit for GND fault is contained to prevent from breaking caused by short between loading driver output pin and GND. Make sure output pin should not short to GND. However in case GND fault occurs, internal circuit prevents IC from breaking by limiting current.

Caution on use

1. Bypass capacitor

Connect bypass capacitor(0.1 μ F) close to this IC pin between power supplies. Also, connect capacitor (10 μ F ~) which is greater capacity and small ESR close to power supply terminal for reducing impedance.

2. TEST terminal

TEST terminal is pulled-up in IC, therefore use it as open or by shorted with VCC.

3. About absolute maximum ratings

Exceeding the absolute maximum ratings, such as the applied voltage or the operating temperature range, may cause permanent device damage. As these cases cannot be limited to the broken short mode or the open mode, if a special mode where the absolute maximum ratings may be exceeded is assumed, it is recommended to take mechanical safety measures such as attaching fuses..

4. About power supply lines

As a measure against the back current regenerated by a counter electromotive force of the motor, a capacitor to be used as a regenerated-current path can be installed between the power supply and GND and its capacitance value should be determined after careful check that any problems, for example, a leak capacitance of the electrolytic capacitor at low temperature, are not found in various characteristics.

5. About GND potential

The electric potential of the GND terminal must be kept lowest in the circuitry at any operation states

6. About thermal design

With consideration of the power dissipation (Pd) under conditions of actual use, a thermal design provided with an enough margin should be done.

7. About operations in a strong electric field

When used in a strong electric field, note that a malfunction may occur.

8. ASO

When using this IC, the output Tr must be set not to exceed the values specified in the absolute maximum ratings and ASO.

9. Thermal shutdown circuit

This IC incorporates a thermal shutdown circuit (TSD circuit). When the chip temperature reaches the value shown below, the coil output to the motor will be set to open.

The thermal shutdown circuit is designed only to shut off the IC from a thermal runaway and not intended to protect or guarantee the entire IC functions.

Therefore, users cannot assume that the TSD circuit once activated can be used continuously in the subsequent operations.

TSD ON Temperature [°C](typ.)	Hysteresis Temperature [°C](typ.)
175	25

10. About earth wiring patterns

When a small signal GND and a large current GND are provided, it is recommended that the large current GND pattern and the small signal GND pattern should be separated and grounded at a single point of the reference point of the set in order to prevent the voltage of the small signal GND from being affected by a voltage change caused by the resistance of the pattern wiring and the large current.

Make sure that the GND wiring patterns of the external components will not change, too.

11. About each input terminal

This IC is a monolithic IC which has a P+isolations and P substrate to isolate elements each other.

This P layer and an N layer in each element form a PN junction to construct various parasitic elements.

Due to the IC structure, the parasitic elements are inevitably created by the potential relationship.

Activation of the parasitic elements can cause interference between circuits and may result in a malfunction or, consequently, a fatal damage. Therefore, make sure that the IC must not be used under

conditions that may activate the parasitic elements, for example, applying the lower voltage than the ground level(GND, P substrate) to the input terminals.

Note that, while not applying the power supply voltage to the IC, any voltage must not be applied to the input terminals. In addition, do not apply the voltage to input terminals without applying the

power supply voltage to the IC. Also while applying the power supply voltage, each input terminal must be the power supply voltage or less; or within the guaranteed values in the electric characteristics.

Notes

- No technical content pages of this document may be reproduced in any form or transmitted by any means without prior permission of ROHM CO.,LTD.
- The contents described herein are subject to change without notice. The specifications for the product described in this document are for reference only. Upon actual use, therefore, please request that specifications to be separately delivered.
- Application circuit diagrams and circuit constants contained herein are shown as examples of standard use and operation. Please pay careful attention to the peripheral conditions when designing circuits and deciding upon circuit constants in the set.
- Any data, including, but not limited to application circuit diagrams information, described herein are intended only as illustrations of such devices and not as the specifications for such devices. ROHM CO.,LTD. disclaims any warranty that any use of such devices shall be free from infringement of any third party's intellectual property rights or other proprietary rights, and further, assumes no liability of whatsoever nature in the event of any such infringement, or arising from or connected with or related to the use of such devices.
- Upon the sale of any such devices, other than for buyer's right to use such devices itself, resell or otherwise dispose of the same, no express or implied right or license to practice or commercially exploit any intellectual property rights or other proprietary rights owned or controlled by
- ROHM CO., LTD. is granted to any such buyer.
- Products listed in this document are no antiradiation design.

The products listed in this document are designed to be used with ordinary electronic equipment or devices (such as audio visual equipment, office-automation equipment, communications devices, electrical appliances and electronic toys).

Should you intend to use these products with equipment or devices which require an extremely high level of reliability and the malfunction of which would directly endanger human life (such as medical instruments, transportation equipment, aerospace machinery, nuclear-reactor controllers, fuel controllers and other safety devices), please be sure to consult with our sales representative in advance.

It is our top priority to supply products with the utmost quality and reliability. However, there is always a chance of failure due to unexpected factors. Therefore, please take into account the derating characteristics and allow for sufficient safety features, such as extra margin, anti-flammability, and fail-safe measures when designing in order to prevent possible accidents that may result in bodily harm or fire caused by component failure. ROHM cannot be held responsible for any damages arising from the use of the products under conditions out of the range of the specifications or due to non-compliance with the NOTES specified in this catalog.

Thank you for your accessing to ROHM product informations.

More detail product informations and catalogs are available, please contact your nearest sales office.

ROHM Customer Support System

THE AMERICAS / EUROPE / ASIA / JAPAN

www.rohm.com

Contact us : webmaster@rohm.co.jp