

Capacitive sensor

BC20-Q20-AN4X2/S400

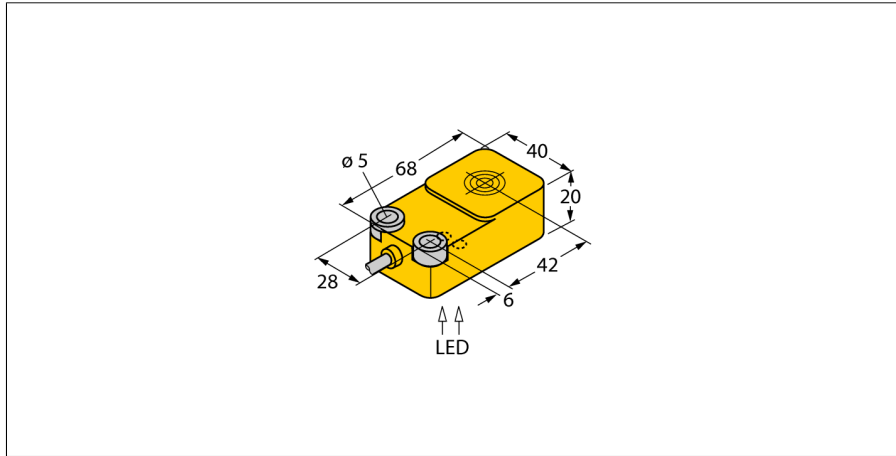

- Rectangular, height 20mm
- Active face on top
- Plastic, PBT-GF30-V0
- Fine adjustment via potentiometer
- DC 3-wire, 10...65 VDC
- NO contact, NPN output
- Cable connection

Wiring Diagram

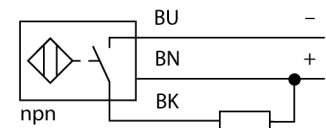

Functional principle

Capacitive proximity switches are designed for non-contact and wear-free detection of electrically conductive as well as non-conductive metal objects.

Type designation	BC20-Q20-AN4X2/S400
Ident-No.	2530104
Rated switching distance (flush)	20 mm
Rated switching distance (non-flush)	20 mm
Secured operating distance	≤ (0.72 x S _n) mm
Hysteresis	2...20 %
Temperature drift	type 20 %
Repeat accuracy	≤ 2 % of full scale
Ambient temperature	-25...+70 °C
Operating voltage	10...65 VDC
Residual ripple	≤ 10 % U _s
DC rated operational current	≤ 200 mA
No-load current I ₀	≤ 15 mA
Residual current	≤ 0.1 mA
Switching frequency	0.1 kHz
Isolation test voltage	≤ 0.5 kV
Output function	3-wire, NO contact, NPN
Short-circuit protection	yes/ Cyclic
Voltage drop at I ₀	≤ 1.8 V
Wire breakage/Reverse polarity protection	yes/ Complete
Approvals	UL
Design	Rectangular,Q20
Dimensions	68 x 40 x 20 mm
Housing material	Plastic, PBT-GF30-V0
Active area material	Plastic, PBT-GF30-V0
Electrical connection	Cables
Cable quality	Ø 5.2mm, LifYY, PVC, 2 m
Cable cross section	3 x 0.34 mm ²
Vibration resistance	55 Hz (1 mm)
Shock resistance	30 g (11 ms)
Protection class	IP67
MTTF	1080 years acc. to SN 29500 (Ed. 99) 40 °C
Packaging unit	1
Power-on indication	LED, Green
Switching state	LED, Yellow
Included in delivery	MH-Q20

Capacitive sensor
BC20-Q20-AN4X2/S400

Accessories

Type code	Ident-No.	Description	
MW-Q14/Q20	6945006	Mounting bracket for rectangular Q14 or Q20; material VA 1.4301	