

Surface mount switching diode FEATURES

- Fast Switching Speed.
- Surface Mount Package Ideally Suited For Automatic Insertion
- For General Purpose Switching Applications.

APPLICATIONS

- Surface mount fast switching diode



ORDERING INFORMATION

Type No.	Marking	Package Code
BAV19W	A8	SOD-123
BAV20W	T2	SOD-123
BAV21W	T3	SOD-123

MAXIMUM RATING @ Ta=25°C unless otherwise specified

Characteristic	Symbol	BAV19W	BAV20W	BAV21W	Unit
Non-Repetitive Peak Reverse Voltage	V_{RM}	120	200	250	V
Peak Repetitive Reverse Voltage	V_{RRM}				
Working Peak Reverse Voltage	V_{RWM}	100	150	200	V
DC Reverse Voltage	V_R				
RMS Reverse Voltage	$V_{R(RMS)}$	71	106	141	V
Forward Continuous Current	I_{FM}	400			mA
Average Rectified Output Current	I_o	200			mA
Non-Repetitive Peak Forward Surge Current @t=1.0 μs	I_{FSM}	2.5			A
@t=1.0 s		0.5			
Repetitive Peak Forward Surge Current	I_{FRM}	625			mA
Power Dissipation	P_d	250			mW
Thermal Resistance Junction to Ambient Air	$R_{θJA}$	500			°C/W
Operating and Storage Temperature Range	T_j, T_{STG}	-65 to+150			°C

SK MAKE CONSCIOUS PRODUCT

CONSCIOUS PRODUCTS BEGIN WITH CONSCIOUS PEOPLE



Surface mount switching diode

ELECTRICAL CHARACTERISTICS @ $T_a=25^\circ\text{C}$ unless otherwise specified

Characteristic	Symbol	Min	Max	Unit	Test Condition
Maximum Forward Voltage	V_{F1} V_{F2}	-	1.0 1.25	V	$I_F=100\text{mA}$ $I_F=200\text{mA}$
Reverse Current BAV19W BAV20W BAV21W	I_R	-	0.1	μA	$V_R=100\text{V}$ $V_R=150\text{V}$ $V_R=200\text{V}$
Junction Capacitance	C_j	-	5.0	pF	$V_R=0, f=1.0\text{MHz}$
Reverse Recovery Time	t_{rr}	-	50	ns	$I_F=I_R=30\text{mA}$, $I_{rr}=0.1 \times I_R, R_L=100\Omega$

TYPICAL CHARACTERISTICS @ $T_a=25^\circ\text{C}$ unless otherwise specified

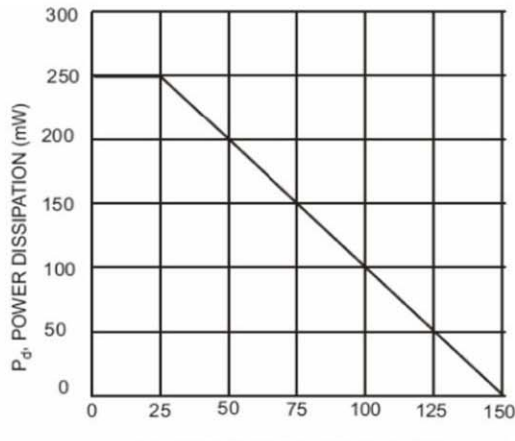

T_A , AMBIENT TEMPERATURE ($^\circ\text{C}$)
Fig. 1 Power Derating Curve

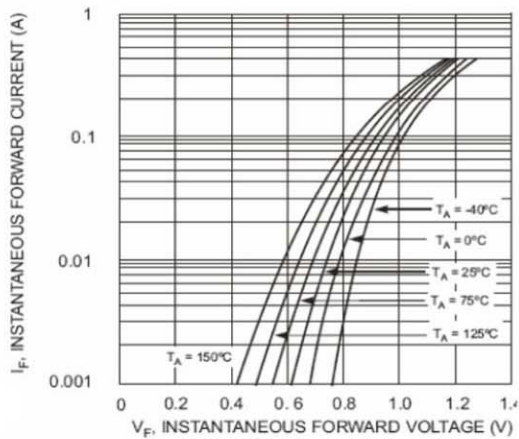
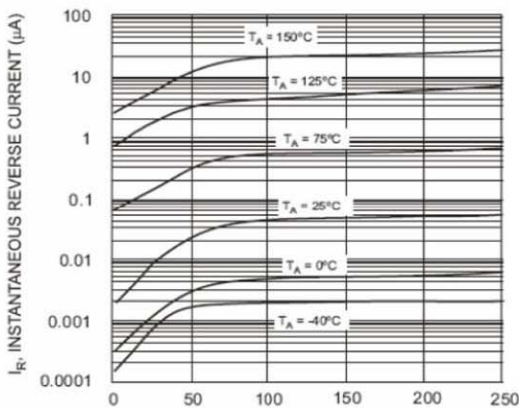
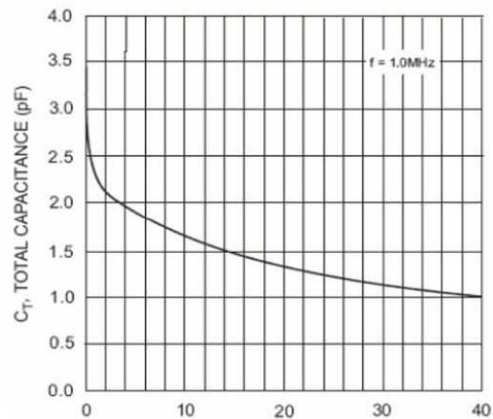

Fig. 2 Typical Forward Characteristics



V_R , INSTANTANEOUS REVERSE VOLTAGE (V)
Fig. 3 Typical Reverse Characteristics



V_R , REVERSE VOLTAGE (V)
Fig. 4 Typical Capacitance vs. Reverse Voltage

SK MAKE CONSCIOUS PRODUCT

CONSCIOUS PRODUCTS BEGIN WITH CONSCIOUS PEOPLE



Surface mount switching diode
PACKAGE OUTLINE

Plastic surface mounted package

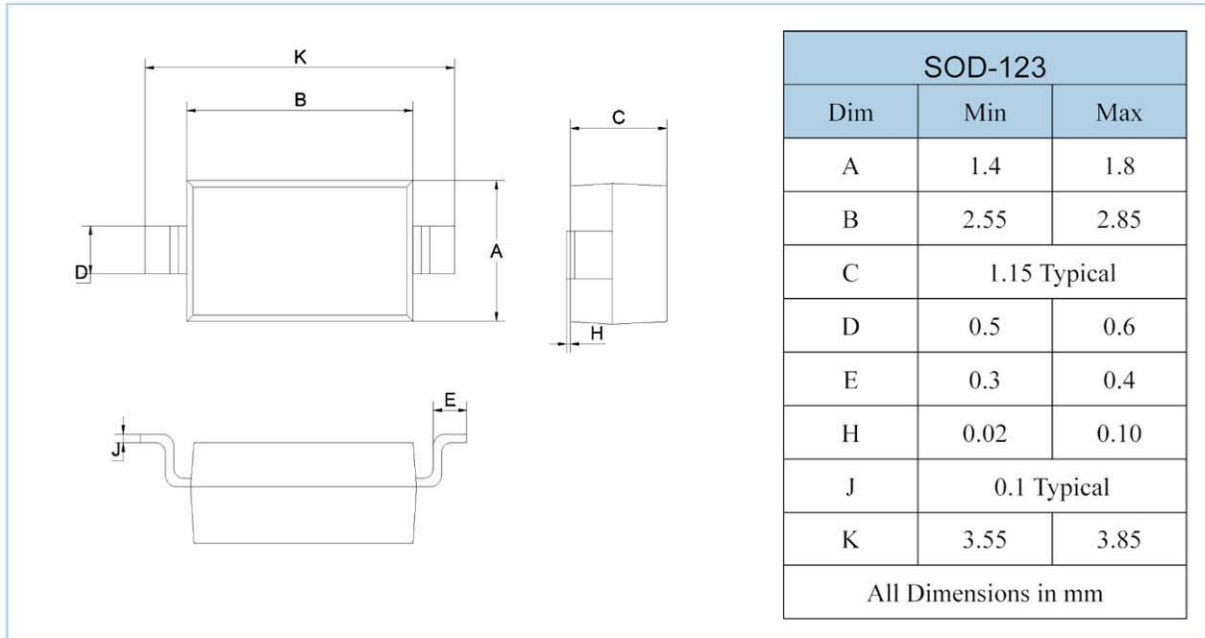

SOLDERING FOOTPRINT

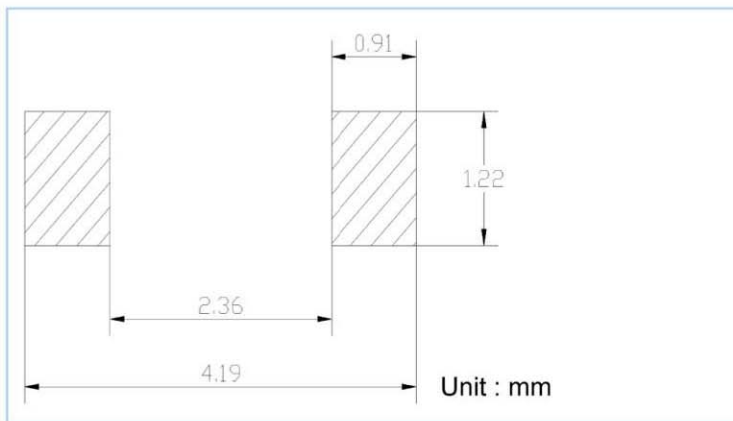

PACKAGE INFORMATION

Device	Package	Shipping
BAV19W/20W/21W	SOD-123	3000/Tape&Reel

SK MAKE CONSCIOUS PRODUCT
 CONSCIOUS PRODUCTS BEGIN WITH CONSCIOUS PEOPLE

