

SOD123 Plastic-Encapsulate Diodes

Schottky Rectifier

Features

- V_R 40V
- I_{FAV} 1A

Applications

- Low Voltage Rectification
- Low Power Consumption Applications
- High Efficiency DC/DC Conversion

Marking

- SL

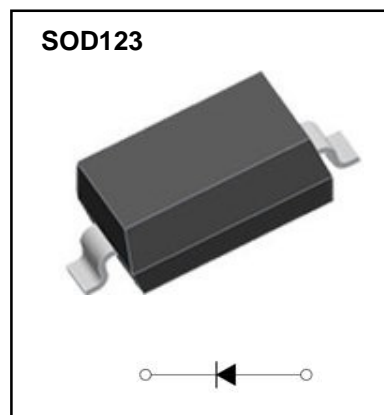

Limiting Values (Absolute Maximum Rating)

Parameter	Symbol	Value	Unit
DC reverse voltage	V_R	40	V
Mean rectifying current	I_o	1	A
Non-repetitive Peak Forward Surge Current @ $t=8.3ms$	I_{FSM}	15	A
Power Dissipation	P_d	0.35	W
Thermal Resistance from Junction to Ambient	$R_{\theta JA}$	285	$^{\circ}C/W$
Junction Temperature	T_J	125	$^{\circ}C$
Storage Temperature	T_{STG}	-55 ~ +150	$^{\circ}C$

Electrical Characteristics ($T_a=25^{\circ}C$ Unless otherwise specified)

Parameter	Symbol	Test Condition	Min	Type	Max	Unit
Reverse voltage	V_{BR}	$I_R = 250\mu A$	40	50		V
Forward voltage	V_F	$I_F = 0.5A$	0	0.42	0.50	V
		$I_F = 1.0A$	0	0.48	0.55	V
		$I_F = 3.0A$	0	0.80	0.90	V
Reverse current	I_R	$V_R = 40V$		5	50	μA
Diode capacitance	C_D	$V_R = 4V, f = 1MHz$		50		pF

Typical Characteristics

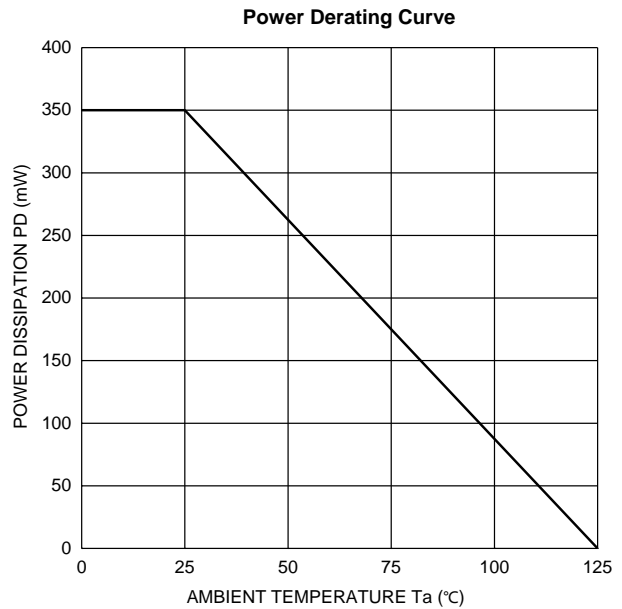
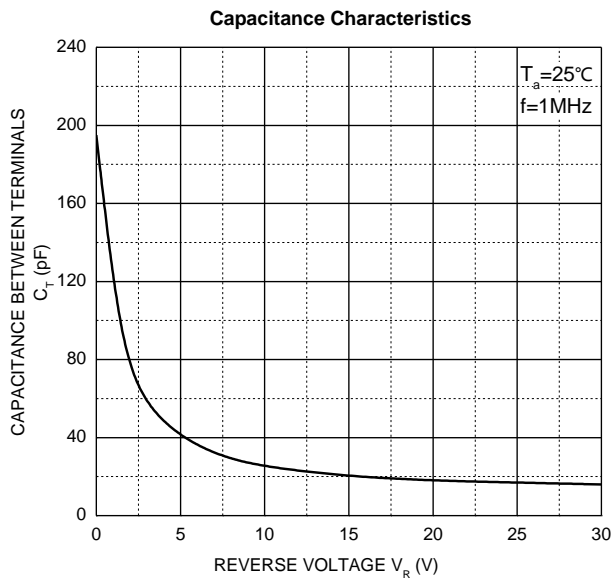
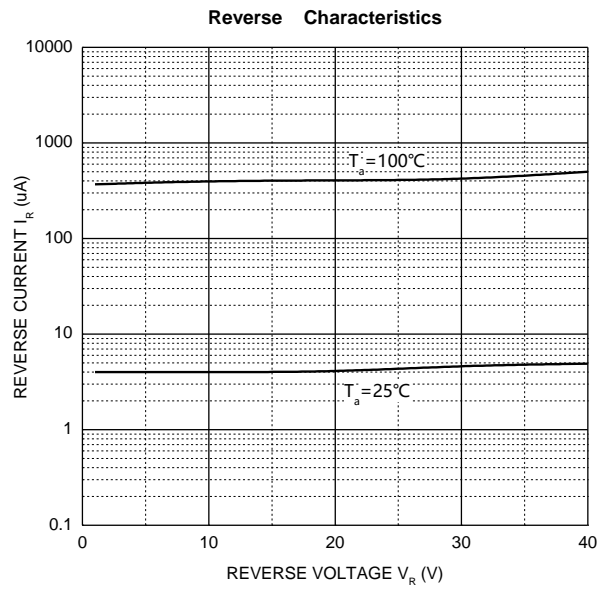
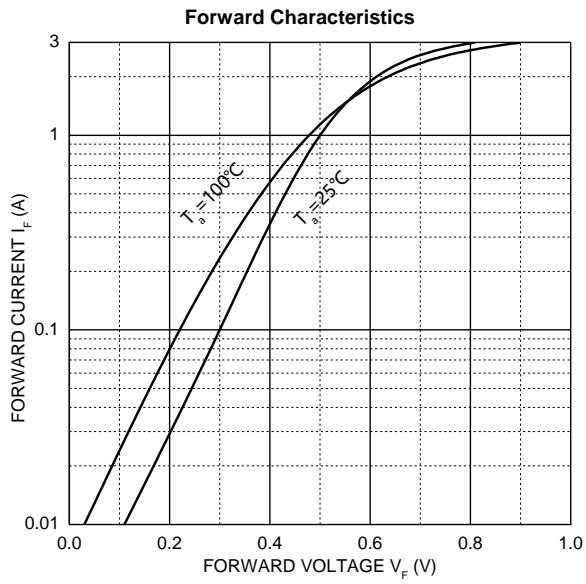

SOD-123 Package Outline Dimensions

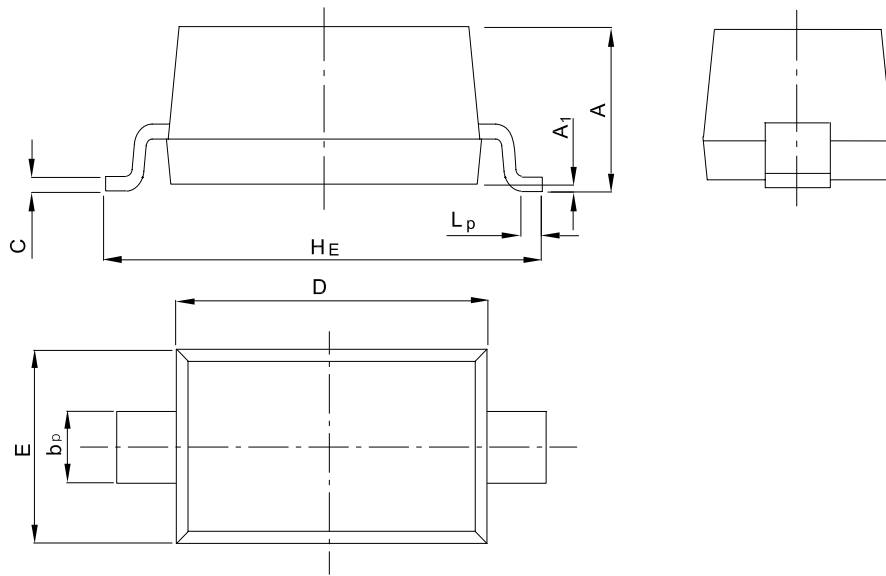

UNIT	A	b _p	C	D	E	H _E	A ₁	L _p
mm	1.20 0.90	0.60 0.50	0.135 0.100	2.75 2.55	1.65 1.55	3.85 3.55	0.10 0.01	0.50 0.20

SOD-123 Suggested Pad Layout

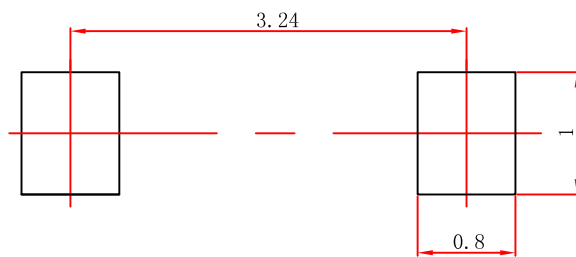

Note:

1. Controlling dimension: in millimeters.
2. General tolerance: ± 0.05 mm.
3. The pad layout is for reference purposes only.

NOTICE

JSKD reserve the right to make modifications, enhancements, improvements, corrections or other changes without further notice to any product herein. JSKD does not assume any liability arising out of the application or use of any product described herein.

Reel Taping Specifications For Surface Mount Devices-SOD123

SOD123 Embossed Carrier Tape Configuration: Figure 3.0

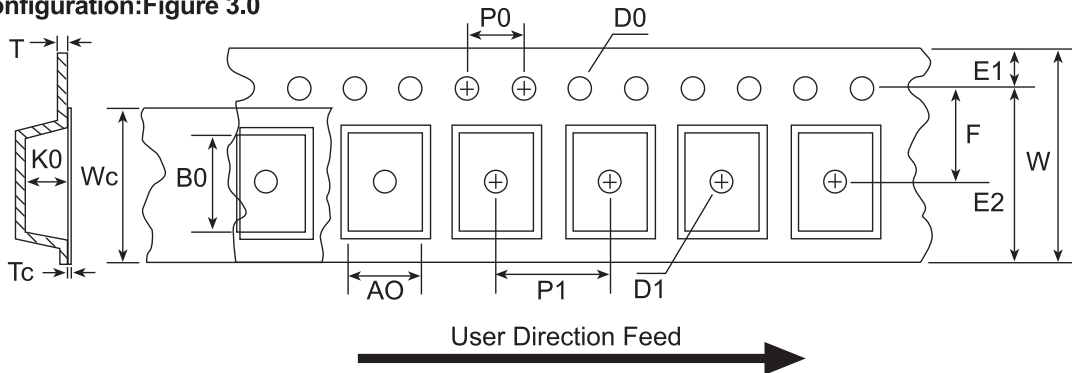

Dimensions are millimeter

Pkg type	A0	B0	W	D0	D1	E1	E2	F	P1	P0	K0	T	Wc	Tc
SOD123 (8mm)	1.85 +/-0.10	3.94 +/-0.10	8.0 +/-0.3	1.50 +/-0.125	1.125 +/-0.125	1.75 +/-0.10	6.25 min	3.50 +/-0.05	4.0 +/-0.10	4.0 +/-0.10	1.50 +/-0.10	0.20 +/-0.020	5.2 +/-0.20	0.06 +/-0.02

Notes: A0, B0 and K0 dimensions are determined with respect to the EW Jeced RS-481 rotational and lateral movement requirements (see sketches A, B and C).

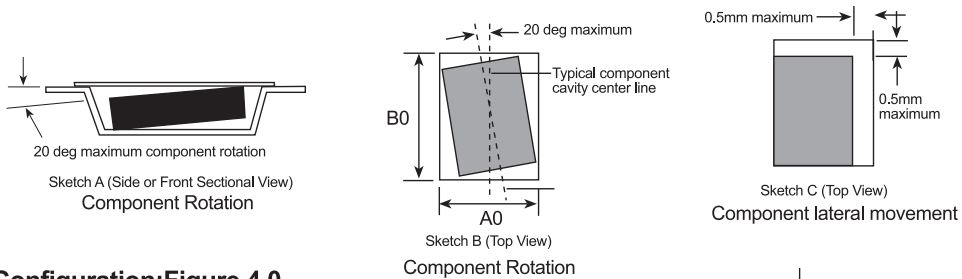

SOD123 Reel Configuration: Figure 4.0

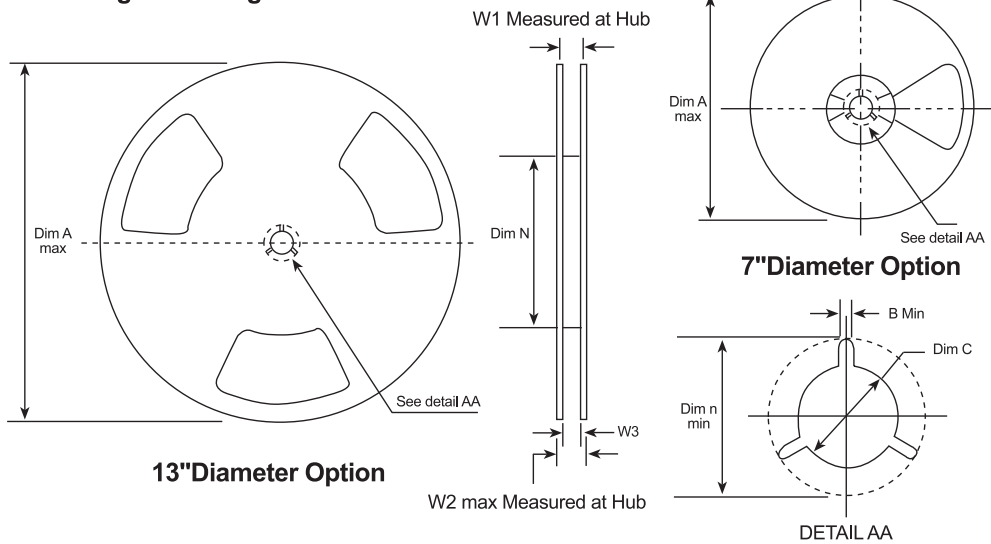

Dimensions are in inches and millimeter

Type Size	Reel Option	Dim A	Dim B	Dim C	Dim D	Dim N	Dim W1	Dim W2	Dim W3 (LSL-USL)
8mm	7" Dia	7.00 177.8	0.059 1.5	512+0.020/-0.008 13+0.5/-0.2	0.795 20.0	2.165 55	0.331+0.059/-0.000 8.4+1.5/0	0.567 14.4	0.311-0.429 7.9-10.9
8mm	13" Dia	13.00 330	0.059 1.5	512+0.020/-0.008 13+0.5/-0.2	0.795 20.0	4.00 100	0.331+0.059/-0.000 8.4+1.5/0	0.567 14.4	0.311-0.429 7.9-10.9