

AZ88943

High-Speed Limiting Post Amplifier

FEATURES

- Up to 2.5Gbps operation
- Differential PECL Inputs
- Differential PECL Outputs
- Open Drain TTL/CMOS SD Output
- TTL/CMOS Enable Input
- High-Speed SiGe Process

PACKAGE AVAILABILITY

PACKAGE	PART NO.	MARKING
TSSOP 10	AZ88943T	AZ88943
TSSOP 10 T&R	AZ88943TR1	AZ88943
TSSOP 10 T&R	AZ88943TR2	AZ88943

DESCRIPTION

The AZ88943 is a limiting post amplifier usable at data rates up to 2.5Gbps. It is ideal for use as a post amplifier following a transimpedance amplifier.

The AZ88943 contains a programmable signal detect function to determine when the input signal is present. This information can be used with the /EN input pin to disable the output under loss of signal conditions. The detect threshold can be set with a resistor divider between V_{CC} and V_{REF} . The SD output is an open drain compatible with CMOS and TTL.

The outputs produce standard PECL 100K voltage compensated levels.

PIN DESCRIPTION

PIN	FUNCTION
D_{IN} , $/D_{IN}$	Differential Inputs
D_{OUT} , $/D_{OUT}$	PECL Outputs
/EN	Output Enable
SD_{LVL}	Signal Detect Threshold
SD	SD Output
V_{REF}	Reference Voltage Output
V_{CC}	Positive Voltage
GND	Ground

PINOUT ASSIGNMENT

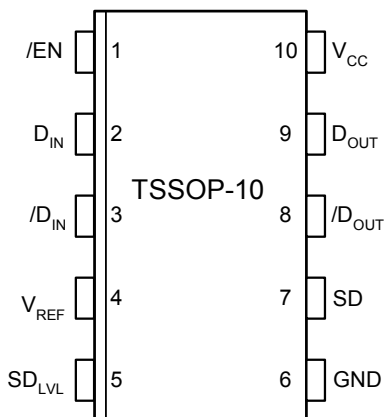

BLOCK DIAGRAM

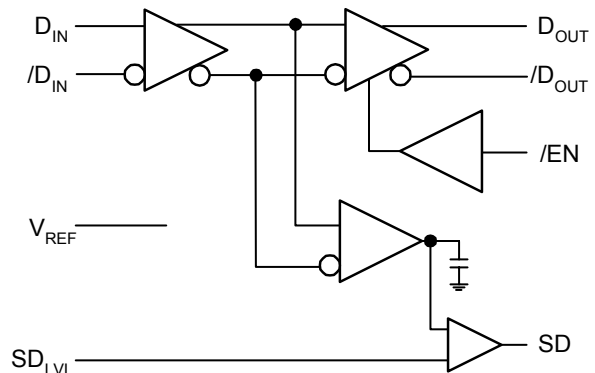

Absolute Maximum Ratings are those values beyond which device life may be impaired

Symbol	Character	Value	Unit
V _{CC}	DC Supply Voltage (Referenced to GND)	4.5	V
T _A	Operating Temperature Range (In Free-Air)	-40 to +85	°C
T _{STG}	Storage Temperature Range	-65 to +125	°C
D _{IN} , /D _{IN}	Input Voltage	0 to V _{CC}	V
/EN	Input Voltage	0 to V _{CC}	V
LOS _{LVL}	Input Voltage	0 to V _{CC}	V
V _{REF}	Output Voltage	V _{CC} -2V to V _{CC}	V
D _{OUT} , /D _{OUT}	Output Voltage	V _{CC} -2V to V _{CC}	V

DC Characteristics (V_{CC} = 3.0V to 3.6V, R_{LOAD} = 50Ω to V_{CC}-2V)

Symbol	Characteristic	-40°C		0°C		25°C			85°C		Unit
		Min	Max	Min	Max	Min	Typ	Max	Min	Max	
I _{EE}	Power Supply Current ¹		40		40		30	40		45	mA
V _{OH}	Output HIGH Voltage	V _{CC} -1085	V _{CC} -880	V _{CC} -1025	V _{CC} -880	V _{CC} -1025	V _{CC} -955	V _{CC} -880	V _{CC} -1025	V _{CC} -880	mV
V _{OL}	Output LOW Voltage	V _{CC} -1830	V _{CC} -1555	V _{CC} -1810	V _{CC} -1620	V _{CC} -1810	V _{CC} -1705	V _{CC} -1620	V _{CC} -1810	V _{CC} -1620	mV
V _{IH}	/EN Input HIGH Voltage	2.0		2.0		2.0			2.0		mV
V _{IL}	/EN Input LOW Voltage	0.8		0.8		0.8			0.8		mV
V _{OL}	SD Output LOW Voltage ²		0.5		0.5			0.5		0.5	V
V _{REF}	Reference Voltage	V _{CC} -1.38	V _{CC} -1.26	V _{CC} -1.38	V _{CC} -1.26	V _{CC} -1.38		V _{CC} -1.26	V _{CC} -1.38	V _{CC} -1.26	V
I _{IH}	/EN Input HIGH Current		100		100			100		100	μA
V _{CMR}	Common Mode Range	GND+2	V _{CC}	GND+2	V _{CC}	GND+2		V _{CC}	GND+2	V _{CC}	V

1. No output load.
2. I_{OL} = +2mA.

AC Characteristics (V_{CC} = 3.0V to 3.6V, R_{LOAD} = 50Ω to V_{CC}-2V)

Symbol	Characteristic	-40°C		0°C		25°C			85°C		Unit
		Min	Max	Min	Max	Min	Typ	Max	Min	Max	
V _{ID}	Input Voltage Range	5	1800	5	1800	5		1800	5	1800	mV
t _r / t _f	Rise/Fall Time		150		150			150		150	ps
V _{OD}	Diff V _{ID} =15 mVp-p Out V _{ID} =5 mVp-p						600 200				MVp-p
HYS	SD Hysteresis	2	8	2	8	2	4.6	8	2	8	dB
t _{ONL}	SD Release Time Minimum Input		0.5		0.5		0.2	0.5		0.5	μs
t _{ONH}	SD Release Time Maximum Input		0.5		0.5		0.2	0.5		0.5	μs
t _{OFFL}	SD Assert Time		0.5		0.5		0.1	0.5		0.5	μs
V _{SR}	SD Sensitivity Range	5	50	5	50	5		50	5	50	MVp-p

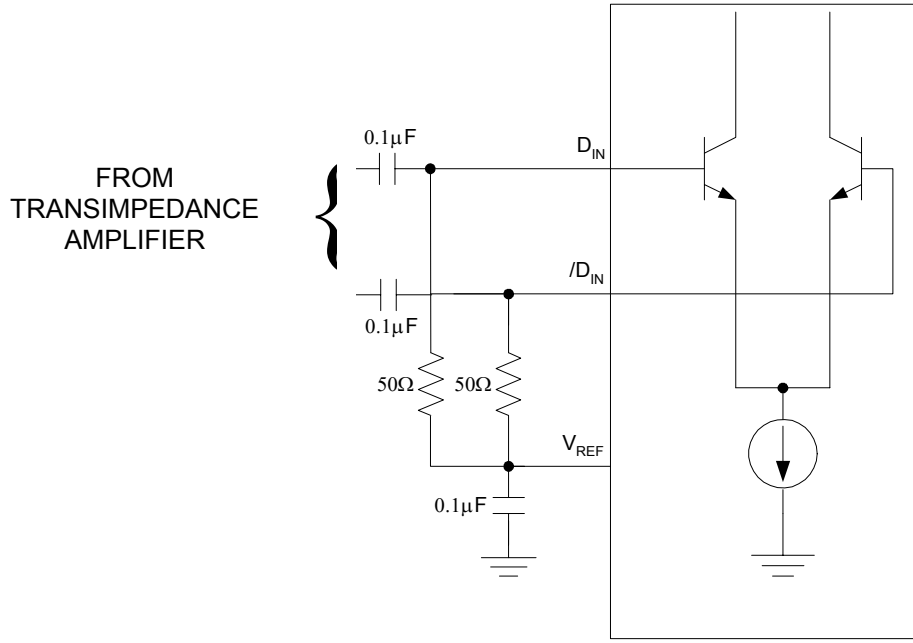

DIFFERENTIAL INPUT CONFIGURATION

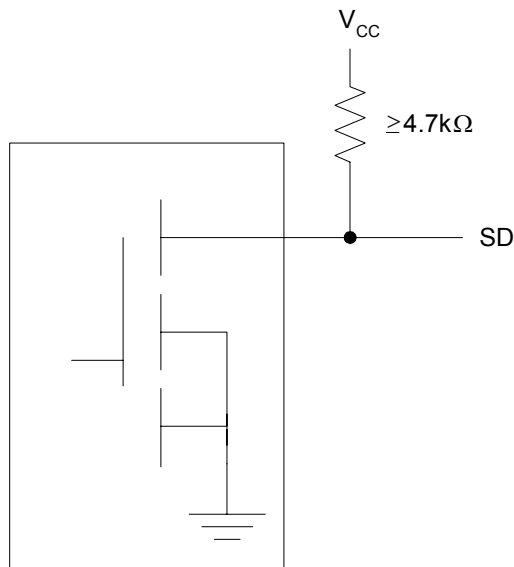

SD OUTPUT

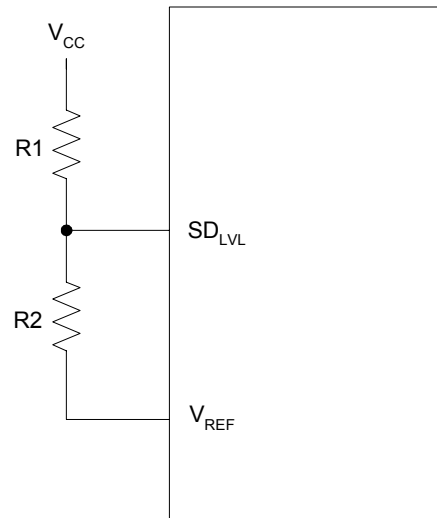

SD_LVL CIRCUIT

NOTES:
 $SD_{LVL} = V_{CC} - 1.32V + \frac{R2 \times 1.32V}{R1 + R2}$
 $R1 + R2 \geq 2.6k\Omega$

**PACKAGE DIAGRAM
TSSOP 10**

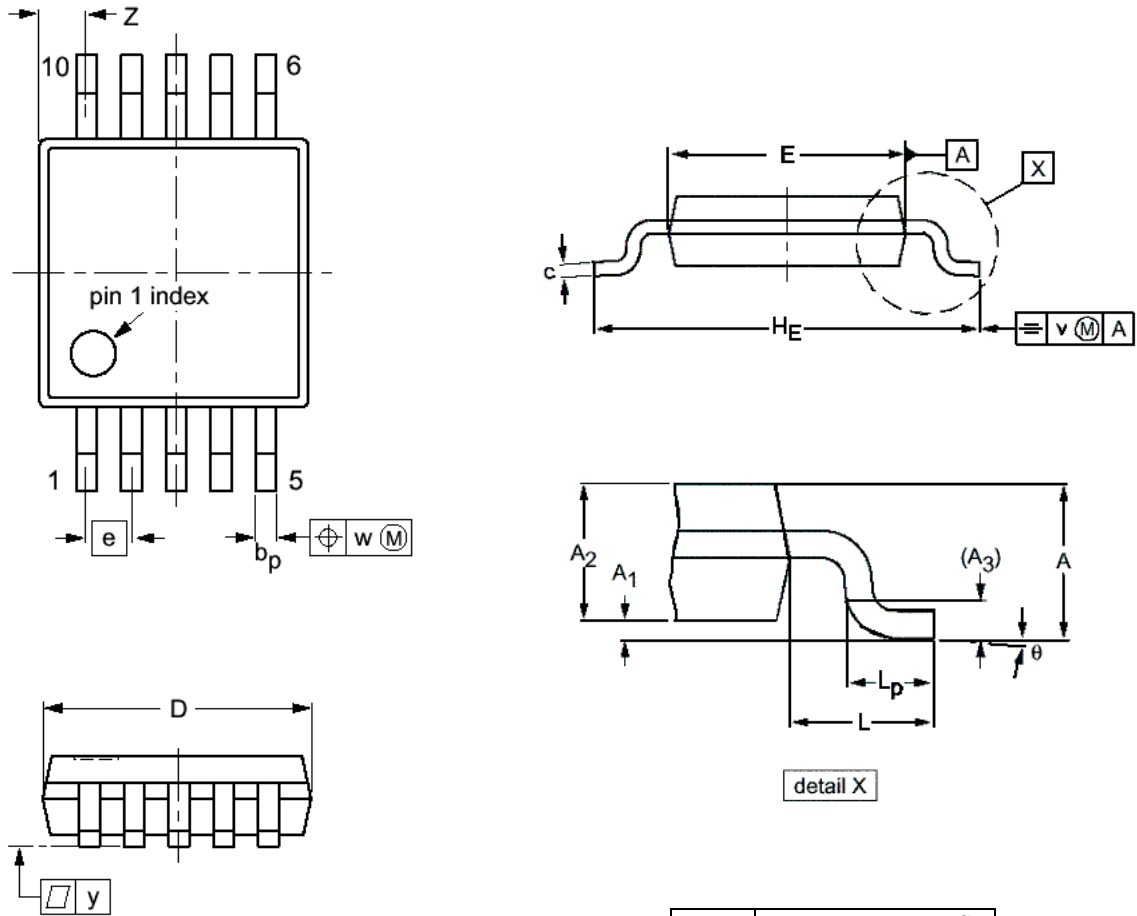

- NOTES:
1. DIMENSIONS D AND E DO NOT INCLUDE MOLD PROTRUSION.
 2. MAXIMUM MOLD PROTRUSION FOR D IS 0.15mm.
 3. MAXIMUM MOLD PROTRUSION FOR E IS 0.25mm.

DIM	MILLIMETERS	
	MIN	MAX
A		1.10
A ₁	0.05	0.15
A ₂	0.80	0.95
A ₃	0.25	
b _p	0.15	0.30
c	0.15	0.23
D ¹	2.90	3.10
E ²	2.90	3.10
e	0.50	
H _E	4.80	5.00
L	0.95	
L _p	0.40	0.70
v	0.10	
w	0.10	
y	0.10	
Z	0.34	0.67
θ	0°	6°

Arizona Microtek, Inc. reserves the right to change circuitry and specifications at any time without prior notice. Arizona Microtek, Inc. makes no warranty, representation or guarantee regarding the suitability of its products for any particular purpose, nor does Arizona Microtek, Inc. assume any liability arising out of the application or use of any product or circuit and specifically disclaims any and all liability, including without limitation special, consequential or incidental damages. Arizona Microtek, Inc. does not convey any license rights nor the rights of others. Arizona Microtek, Inc. products are not designed, intended or authorized for use as components in systems intended to support or sustain life, or for any other application in which the failure of the Arizona Microtek, Inc. product could create a situation where personal injury or death may occur. Should Buyer purchase or use Arizona Microtek, Inc. products for any such unintended or unauthorized application, Buyer shall indemnify and hold Arizona Microtek, Inc. and its officers, employees, subsidiaries, affiliates, and distributors harmless against all claims, costs, damages, and expenses, and reasonable attorney fees arising out of, directly or indirectly, any claim of personal injury or death associated with such unintended or unauthorized use, even if such claim alleges that Arizona Microtek, Inc. was negligent regarding the design or manufacture of the part.