

# @vic AV8550S PNP EPITAXIAL SILICON TRANSISTOR

LOW VOLTAGE HIGH CURRENT  
SMALL SIGNAL PNP  
TRANSISTOR

## FEATURES

- \*Collector current up to 700mA
- \*Collector-Emitter voltage up to 20 V
- \*Complimentary to 8050S

## APPLICATIONS

- \*Class B push-pull audio amplifier
- \*General purpose applications

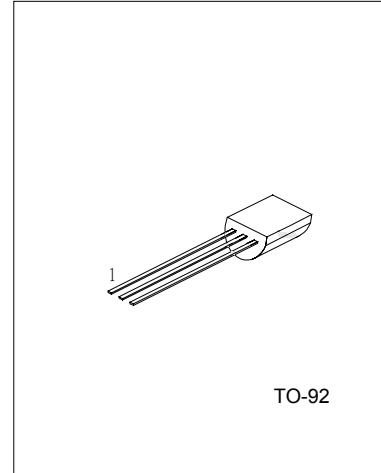

1: EMITTER 2: COLLECTOR 3: BASE

## ABSOLUTE MAXIMUM RATINGS ( Ta=25°C , unless otherwise specified )

PARAMETERS	SYMBOL	RATING	UNITS
Collector-base voltage	V <sub>CB0</sub>	-30	V
Collector-emitter voltage	V <sub>CEO</sub>	-20	V
Emitter-base voltage	V <sub>EBO</sub>	-5	V
Collector dissipation(Ta=25°C)	P <sub>c</sub>	1	W
Collector current	I <sub>c</sub>	-700	mA
Junction Temperature	T <sub>j</sub>	150	°C
Storage Temperature	T <sub>STG</sub>	-65 ~ +150	°C

## ELECTRICAL CHARACTERISTICS(Ta=25°C, unless otherwise specified)

PARAMETER	SYMBOL	TEST CONDITIONS	MIN	TYP	MAX	UNIT
Collector-base breakdown voltage	BV <sub>CB0</sub>	I <sub>c</sub> =-100μA, I <sub>E</sub> =0	-30			V
Collector-emitter breakdown voltage	BV <sub>CEO</sub>	I <sub>c</sub> =-1mA, I <sub>B</sub> =0	-20			V
Emitter-base breakdown voltage	BV <sub>EBO</sub>	I <sub>E</sub> =-100μA, I <sub>c</sub> =0	-5			V
Collector cut-off current	I <sub>CB0</sub>	V <sub>CB</sub> =-30V, I <sub>E</sub> =0			-1	uA
Emitter cut-off current	I <sub>EBO</sub>	V <sub>EB</sub> =-5V, I <sub>c</sub> =0			-100	nA
DC current gain(note)	hFE1	V <sub>CE</sub> =-1V, I <sub>c</sub> =-1mA	100	110	400	
	hFE2	V <sub>CE</sub> =-1V, I <sub>c</sub> =-150 mA	120			
	hFE3	V <sub>CE</sub> =-1V, I <sub>c</sub> =-500mA	40			
Collector-emitter saturation voltage	V <sub>CE(sat)</sub>	I <sub>c</sub> =-500mA, I <sub>B</sub> =-50mA			-0.5	V
Base-emitter saturation voltage	V <sub>BE(sat)</sub>	I <sub>c</sub> =500mA, I <sub>B</sub> =-50mA			-1.2	V
Base-emitter saturation voltage	V <sub>BE</sub>	V <sub>CE</sub> =-1V, I <sub>c</sub> =-10mA			-1.0	V
Current gain bandwidth product	f <sub>T</sub>	V <sub>CE</sub> =-10V, I <sub>c</sub> =-50mA	100			MHz
Output capacitance	C <sub>ob</sub>	V <sub>CB</sub> =10V, I <sub>E</sub> =0 f=1MHz		9.0		pF

# @vic AV8550S PNP EPITAXIAL SILICON TRANSISTOR

## CLASSIFICATION OF hFE2

RANK	C	D	E
RANGE	120-200	160-300	280-400

## TYPICAL CHARACTERISTIC CURVES

