

FEATURES

- Normally Open, Single Pole Single Throw
- Control 350 VAC or DC Voltage
- Switch 130 mA Loads
- LED Control Current, 2mA
- Low ON-Resistance
- dv/dt , >500 V/ms
- Isolation Test Voltage, 3750 VAC_{RMS}
- UL, CSA, FCC compatible
- Applications
 - Telecommunications
 - Telecom Switching
 - Tip/Ring Circuits
 - Modem Switching (Laptop, Notebook, Pocket Size)
 - Hookswitch
 - Dial Pulsing
 - Ground Start
 - Ringer Injection
 - Instrumentation
 - Multiplexers
 - Data Acquisition
 - Electronic Switching
 - I/O Subsystems
 - Meters (Watt-Hour, Water, Gas)
 - Medical Equipment
 - High Voltage Test Equipment
 - TRIAC Driver
 - Motor Control
 - Security
 - Aerospace
 - Industrial Controls

DESCRIPTION

The AQW210 is a single pole single throw (SPST), normally open (NO), Mos Relay. The relay can control AC or DC loads currents up to 130 mA, with a supply voltage up to 350 V. The device is packaged in a 8 pin SMD and dual-in line package. Those package offer an insulation dielectric withstand of 3750 VAC_{RMS}.

The coupler consists of a AlGaAs LED that is optically coupled to a dielectrically isolated photodiode array which drives two series connected high voltage MOS transistors. The typical ON-Resistance is 20Ω at 25 mA and is linear up to 50mA. The incremental resistance drops to less than 20Ω beyond 50 mA while reducing internal power dissipation at high load currents.

● Turn on/Turn off time

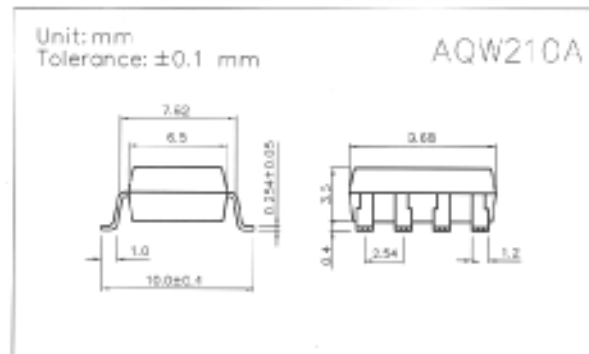
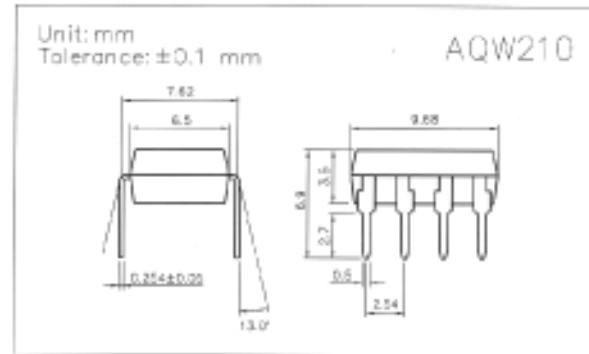

Absolute Maximum Ratings (T_A = 25°C)

Emitter (Input)

| | |
|---------------------------------|----------|
| Reverse Voltage..... | 5.0V |
| Continuous Forward Current..... | 50mA |
| Peak Forward Current (1s)..... | 1A |
| Power Dissipation..... | 100mW |
| Derate Linearly from 25°C..... | 1.3mW/°C |

Detector (Output)

| | |
|-------------------------------|--------|
| Output Breakdown Voltage..... | ±350V |
| Continuous Load Current..... | ±130mA |
| Power Dissipation..... | 500mW |

General Characteristics

| | |
|--|------------------------|
| Isolation Test Voltage..... | 3750VAC _{RMS} |
| Isolation Resistance | |
| V _{IO} = 500V, T _A = 25°C..... | ≥10 ¹⁰ Ω |
| Total Power Dissipation..... | 550mW |
| Derate Linearly from 25°C..... | 2.5mW/°C |
| Storage Temperature Range..... | -40 to +150°C |
| Operating Temperature Range..... | -40 to +85°C |
| Junction Temperature..... | 100°C |
| Soldering Temperature, 2mm from case, 10 sec... | 260°C |

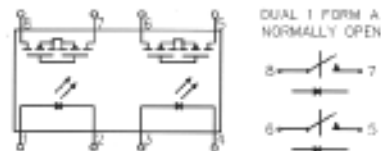

Characteristics

(T_A = 25°C)

| Description | Symbol | Min. | Typ. | Max. | Unit | Test Condition |
|--------------------------|---------------------|------|------|------|------|---|
| Emitter (Input) | | | | | | |
| Forward Voltage | V _F | | 1.8 | 2.0 | V | I _F = 10 mA |
| Operation Input Current | I _{F(ON)} | | | 5 | mA | V _L = ± 20 V, I _L = 100 mA, t = 10 ms |
| Recovery Input Current | I _{F(OFF)} | 0.2 | | | mA | V _L = ± 20 V, I _L = < 5 μA |
| Detector (output) | | | | | | |
| Output Breakdown Voltage | V _B | 350 | | | V | I _B = 50 μA |
| Output Off-State Leakage | I _{T(OFF)} | | 0.2 | 1 | μA | V _T = 100 V, I _F = 0 mA |
| I/O Capacitance | C _{ISO} | | 6 | | pF | I _F = 0, f = 1 MHz |
| ON Resistance | R _{ON} | | 20 | 30 | Ω | I _L = 100 mA, I _F = 10 mA |
| Turn-on Time | T _{ON} | | 0.3 | 1.0 | ms | I _F = 10 mA, V _L = ± 20 V |
| Turn-off Time | T _{OFF} | | 0.7 | 1.5 | ms | t = 10 ms, I _L = ± 100 mA |

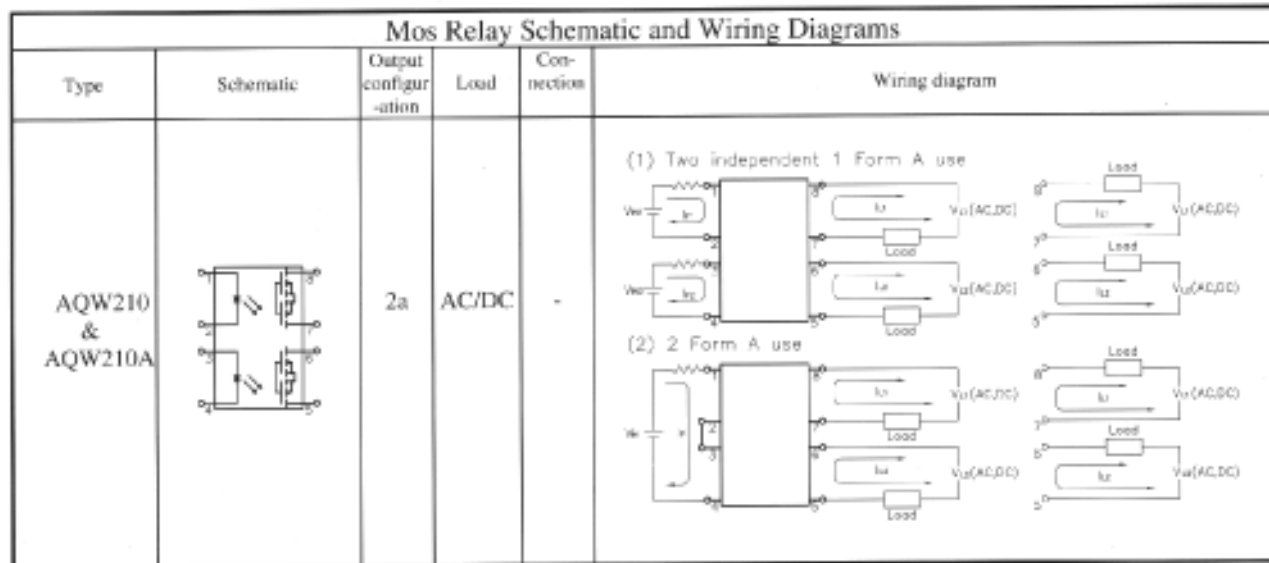

DATA CURVE

Load current vs. ambient temperature
 Allowable ambient temperature:
 -40°C to + 85°C

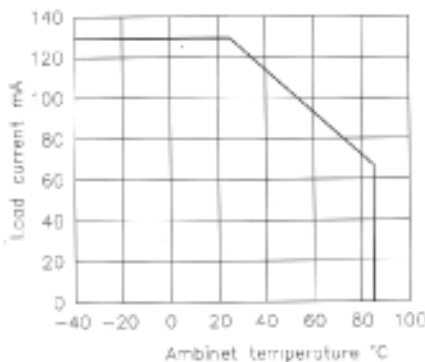

On resistance vs. ambient temperature
 Across terminals 5,7 and 6,8 pin
 LED current: 5 mA
 Continuous load current: 130 mA(DC)

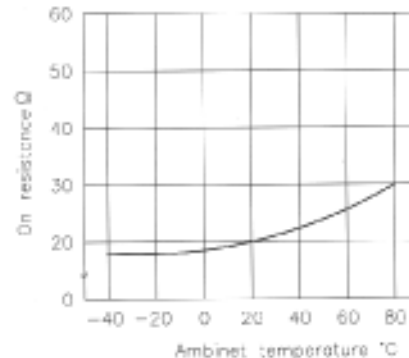

Turn on time vs. ambient temperature
 Load voltage 350 V(DC)
 LED current : 5 mA
 Continuous load current: 130 mA(DC)

