

2-Cell, 200mA, Step-Up DC/DC Converter

FEATURES

- High Efficiency Up To 87%.
- Adjustable Output Voltage with Two Resistors (AIC1633A)
- Power-Saving Shutdown Mode (7 μ A typical).
- Internal 0.8A Switch.
- 120KHz Switching Rate.
- Adjustable Switch Current Limit.
- On-Chip Low Battery Detector.

APPLICATIONS

- Pocket Organizers.
- Electronic Dictionaries.
- Cameras.
- Pagers.
- Bar-Code Scanners.
- LCD Displays.
- Battery Backup Supplies.
- Portable Instruments.

DESCRIPTION

The AIC1633 is a high efficiency step up DC/DC converter. Only four external components are required to deliver a fixed voltage of 3V, 3.3V, or 5V. The output voltage can be externally set to an arbitrary value below breakdown voltage of the power switch for AIC1633A. Efficiency beyond 83% can be easily achieved at 70mA load with 2.2V to 3V input voltages.

Logic-controlled shutdown mode is provided for power saving. Switch current limit can be programmed with a resistor. The low battery detector can be configured as a linear regulator or a burst mode controller performing an extremely low supply current operation.

120KHz switching rate reduces the inductor size. Inductors of 47 μ H to 150 μ H inductance are recommended for most applications.

TYPICAL APPLICATION CIRCUIT

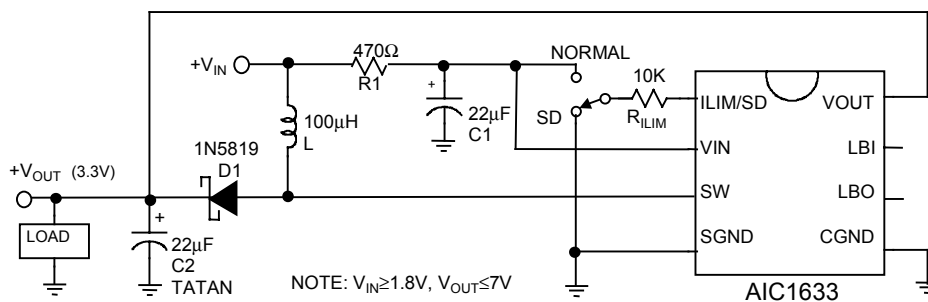

High-Efficiency Step-Up DC/DC Converter

ORDERING INFORMATION

AIC1633 XXX

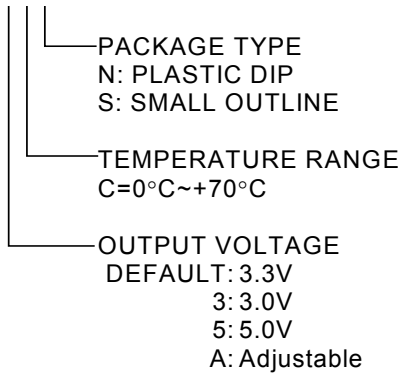

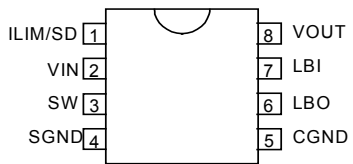
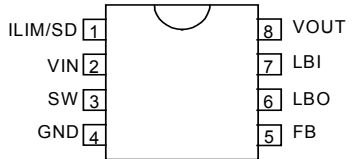
ORDER NUMBER	PIN CONFIGURATION
AIC1633CN AIC1633-3CN AIC1633-5CN (PLASTIC DIP)	TOP VIEW 
AIC1633CS AIC1633-3CS AIC1633-5CS (PLASTIC SO)	
AIC1633ACN (PLASTIC DIP)	TOP VIEW 
AIC1633ACS (PLASTIC SO)	

ABSOLUTE MAXIMUM RATINGS

Supply Voltage	7.0V
Operating Temperature Range	-20°C ~ 80°C
Storage Temperature Range	-65°C ~ 150°C

TEST CIRCUIT

Refer to Typical Application Circuit.

ELECTRICAL CHARACTERISTICS (V_{IN}=3.0V, T_a=25°C, unless otherwise specified.)

PARAMETER	TEST CONDITIONS	MIN.	TYP.	MAX.	UNIT
Input Voltage		1.8		7	V
Output Voltage	I _{LOAD} =70mA AIC1633 AIC1633-3 AIC1633-5	3.16 2.88 4.80	3.3 3 5	3.44 3.12 5.20	V
Switch off Current			105	140	μA
No Load Current	AIC1633/AIC1633-3 AIC1633-5		160 250		μA
Shutdown Mode Current			7	15	μA
Shutdown Recovery Time	V _{IN} =2.5V, I _{LOAD} =70mA		1.8		mS

ELECTRICAL CHARACTERISTICS (CONTINUED)

PARAMETER	TEST CONDITIONS	MIN.	TYP.	MAX.	UNIT
Efficiency	$I_{LOAD} = 70mA$ AIC1633/AIC1633-3 AIC1633-5		87 86		%
Line Regulation	$I_{LOAD} = 40mA$ AIC1633, $V_{IN} = 2.0 \sim 3.3V$ AIC1633-3, $V_{IN} = 2.0 \sim 3.0V$ AIC1633-5, $V_{IN} = 2.2 \sim 4.5V$		0.6 0.6 0.5		% V_{OUT}
Load Regulation	$I_{LOAD} = 170mA$ AIC1633/AIC1633-3 AIC1633-5		0.6 0.5		% V_{OUT}
Oscillator Frequency		90	120	150	KHz
LBI Pin Trip Point		1.17	1.22	1.27	V
FB Threshold Voltage	AIC1633A	0.598	0.617	0.636	V
SW "ON Resistance"	AIC1633/AIC1633-3 AIC1633-5		1.75 1.25		Ω
LBO "ON Resistance"	$V_{IN} = 2V$		45		Ω
SW Off Leakage				1	μA
Input Pin Bias Current				10	nA/Pin
Output Pin Leakage				10	nA/Pin

TYPICAL PERFORMANCE CHARACTERISTICS

Switch Voltage vs Current

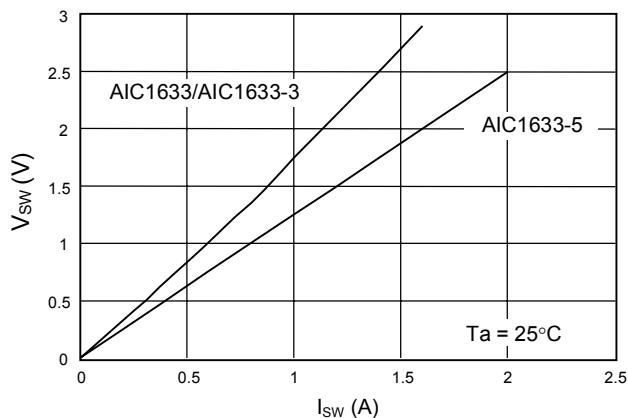

SW ON Resistance vs Temperature

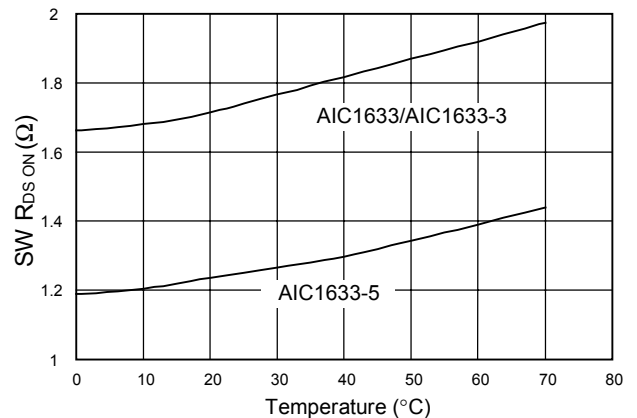

TYPICAL PERFORMANCE CHARACTERISTICS (CONTINUED)

No Load Supply Current vs Input Voltage

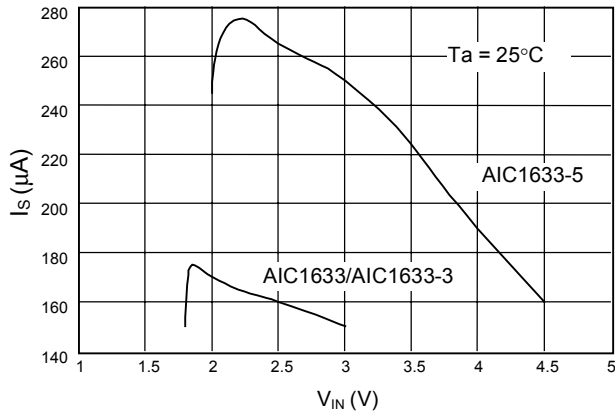

No Load Supply Current vs Temperature

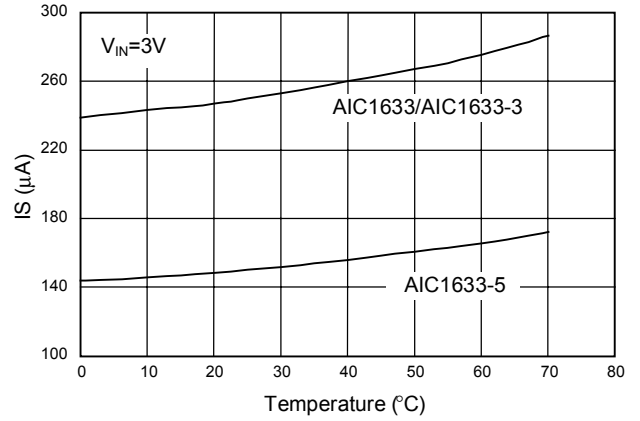

Shutdown Mode Supply Current vs Input Voltage

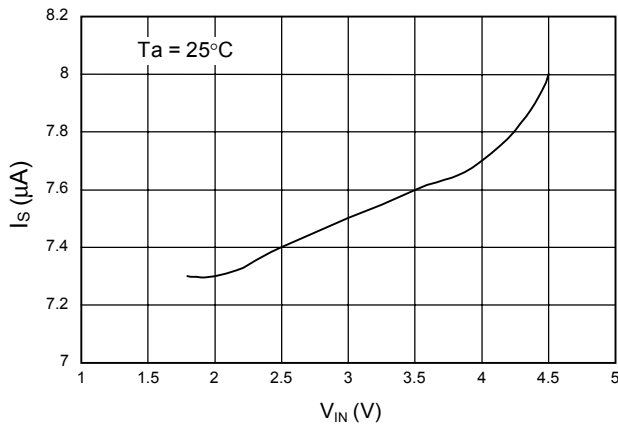

Shutdown Mode Supply Current vs Temperature

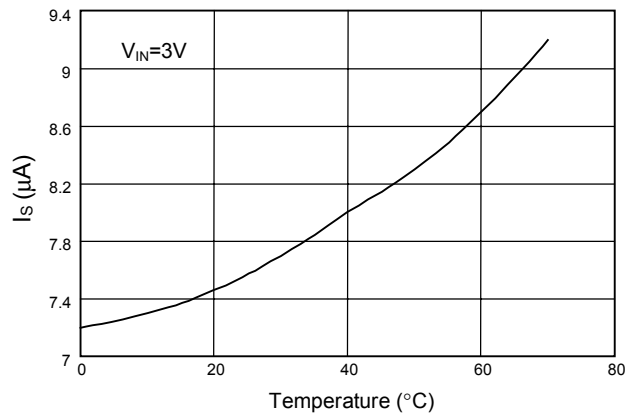

Oscillator Frequency vs Input Voltage

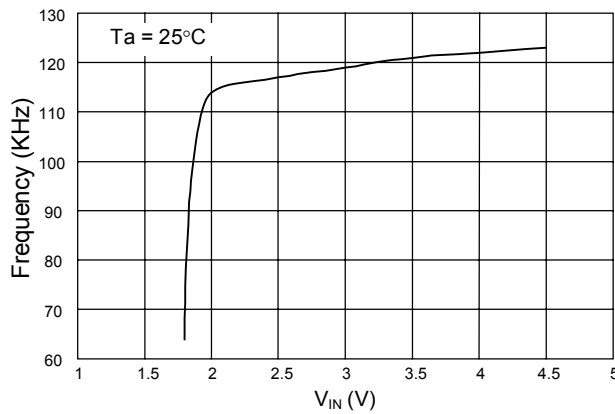

Oscillator Frequency vs Temperature

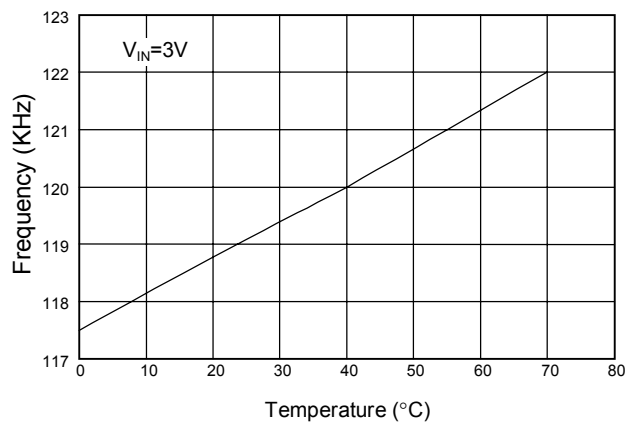

TYPICAL PERFORMANCE CHARACTERISTICS (CONTINUED)

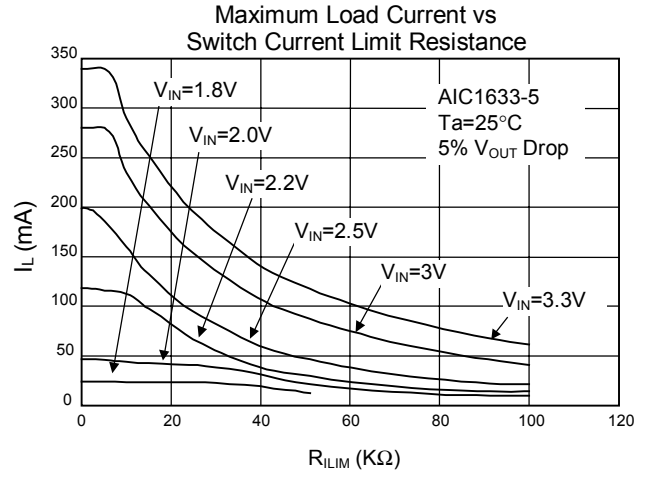
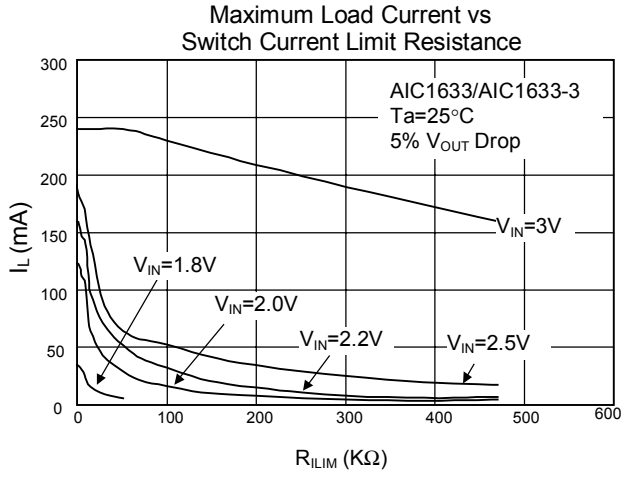

BLOCK DIAGRAM

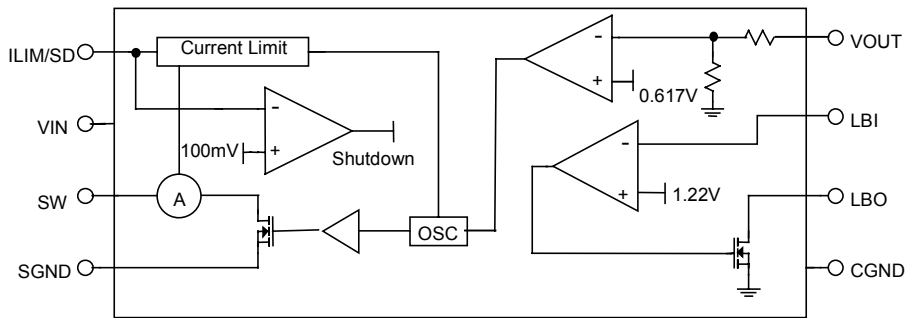

■ PIN DESCRIPTIONS

AIC1633-30/ AIC1633-33 / AIC1633-50

- PIN 1: ILIM/SD-** 1. Connected to VIN pin through a resistor to set the switch peak current. It serves to protect IC and inductor, as well as to improve efficiency and output ripples. However, the current limit resistor limits supply capability of the AIC1633. (See typical performance characteristics). The ILIM/SD pin should be shorted to VIN pin if limiting on switch peak current is not intended.
2. The AIC1633 goes in shutdown mode and consumes less than 10 μ A when ILIM/SD pin is pulled to ground.
- PIN 2: VIN** - Input supply.
- PIN 3: SW** - Drain of the power switch, to be connected to inductor/ diode.
- PIN 4: SGND** - Ground connected to source of power switch.
- PIN 5: CGND** - Ground for control circuits of the IC. It should be separated from SGND to avoid the interference.
- PIN 6: LBO** - Open drain output of the battery low detector, with 45 Ω "ON resistance" at $V_{IN}=2V$. It is pulled low when the voltage on LBI pin is below 1.22V.
- PIN 7: LBI** - The noninverting input of the battery low detector, of which the inverting input is internally connects to 1.22V voltage reference.
- PIN 8: VOUT** - The output voltage feedbacks to the IC through this pin.

AIC1633A

- PIN 1:ILIM/SD-** 1. Connected to VIN pin through a resistor to set the switch peak current. It serves to protect IC and inductor, as well as to improve efficiency and output ripples. However, the current limit resistor limits supply capability of the AIC1633A. (See typical performance characteristics). The ILIM/SD pin should be shorted to VIN pin if limiting on switch peak current is not intended.
2. The AIC1633A goes in shutdown mode and consumes less than 10 μ A when ILIM/SD pin is pulled to ground.
- PIN 2: VIN** - Input supply.
- PIN 3: SW** - Drain of the power switch, to be connected to inductor/ diode.
- PIN 4: GND** - Ground.
- PIN 5: FB** - Output voltage can either be internally set to 5 volt by grounding FB pin, or be externally set to an arbitrary voltage by applying to FB pin the divider voltage of two divider resistors.
- V_{OUT} voltage is given by the following equation:
- $$\frac{R1}{R2} = \frac{V_{OUT}}{0.617} - 1$$
- where R1 = Resistor connected between FB pin and VOUT pin.
R2 = Resistor connected between FB pin and ground.
 V_{OUT} =Output voltage to be set.
- PIN 6: LBO** - Open drain output of the battery low detector, with 45 Ω "ON resistance" at $V_{IN}=2V$. It is pulled low when the voltage on LBI pin is below 1.22V.

AIC1633A (continued)

PIN 7: LBI - The non-inverting input of the battery low detector, of which the inverting input is internally connects to 1.22V voltage reference.

PIN 8: VOUT- The output voltage feedbacks to the IC through this pin. If output voltage was externally set, the VOUT pin can be tied to any low impedance node with voltage between the external power switch threshold and 7V

APPLICATION EXAMPLES

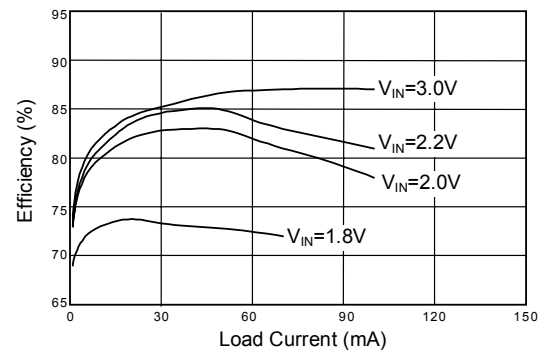
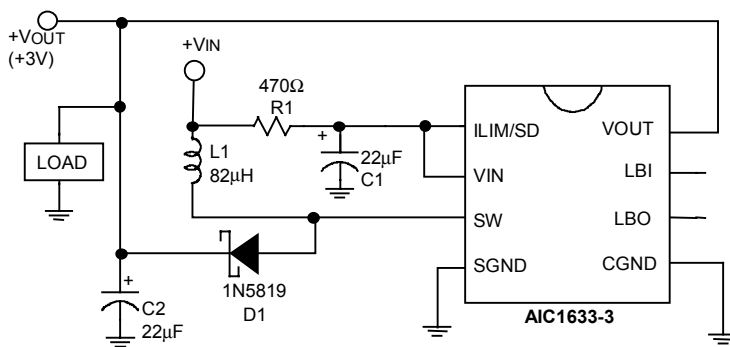

Fig. 1 3V Output Step-Up Converter

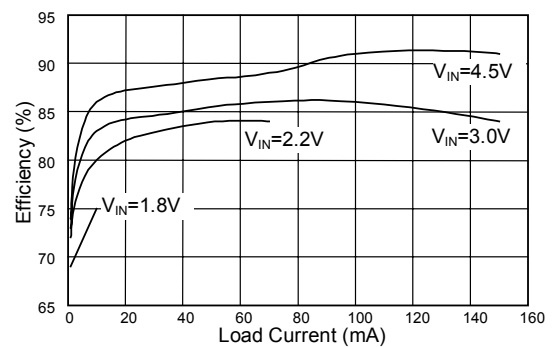
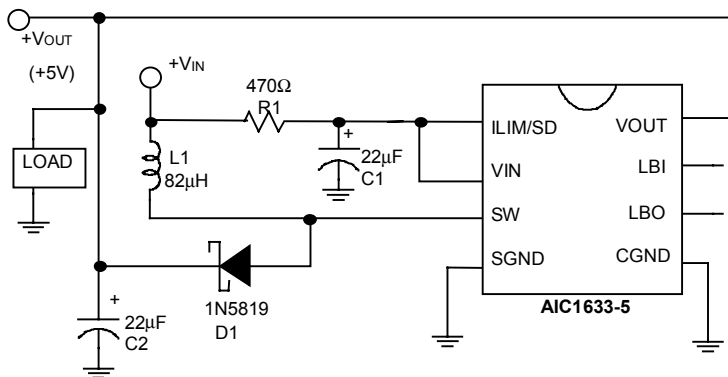
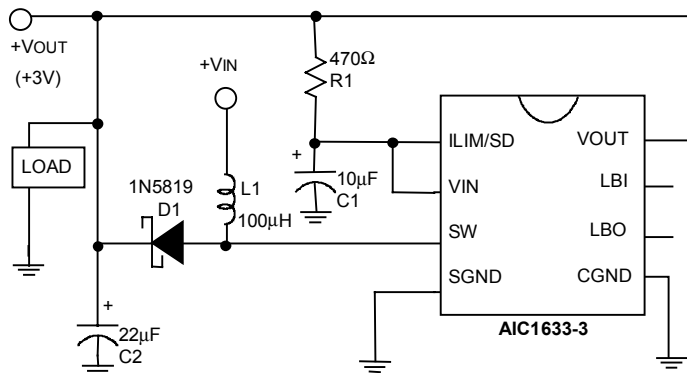

Fig. 2 5V Output Step-Up Converter

APPLICATION EXAMPLES (CONTINUED)



Start-Up V_{IN} Voltage = 1.4V

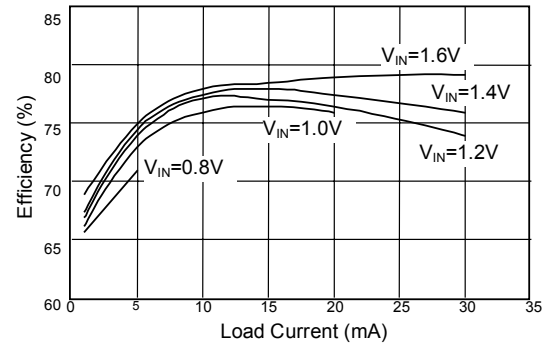

Fig. 3 1-Cell Input 3V Output Step-Up Converter

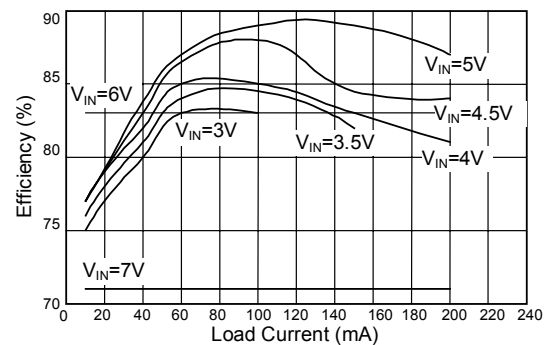
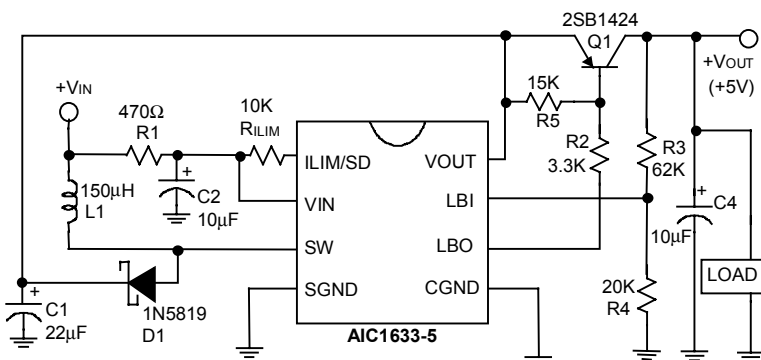
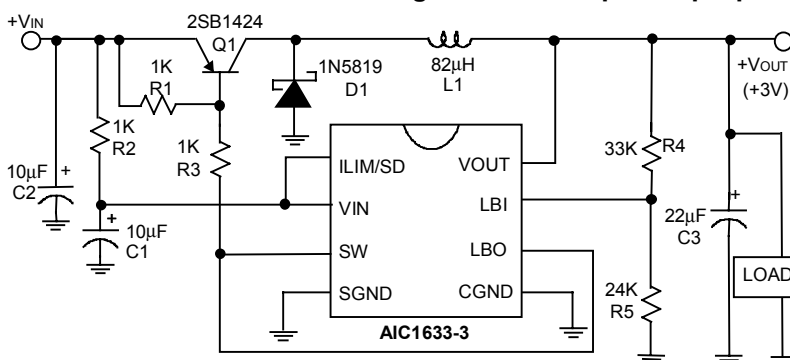

Fig. 4 4-Cell Input Step-Up/ Step-Down Converter



V_{OUT} Ripple May Be Large at $V_{IN}=3V$ Condition

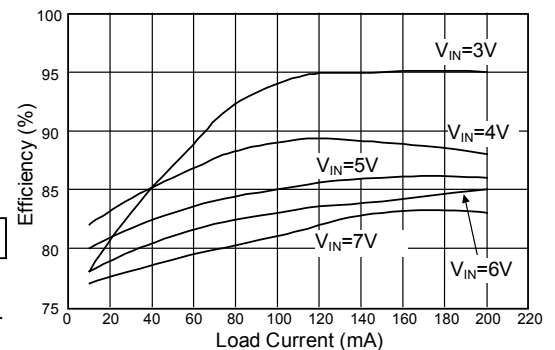

Fig. 5 3-Cell Input 3V Output Step-Down Converter

APPLICATION EXAMPLES (CONTINUED)

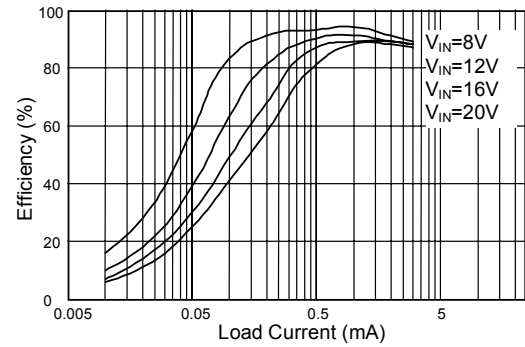
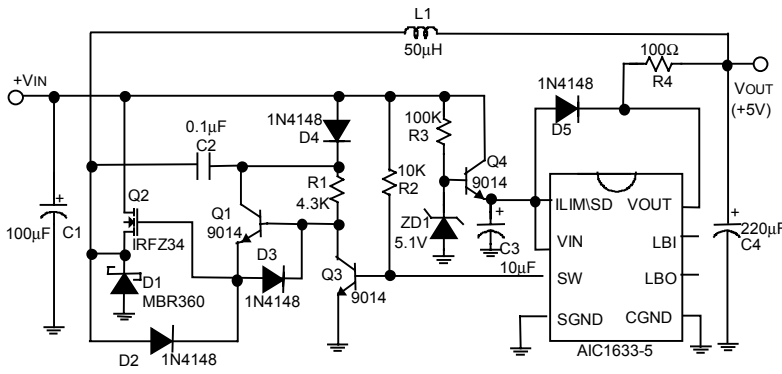

Fig. 6 Boost-Driven 5V Output Step-Down Converter

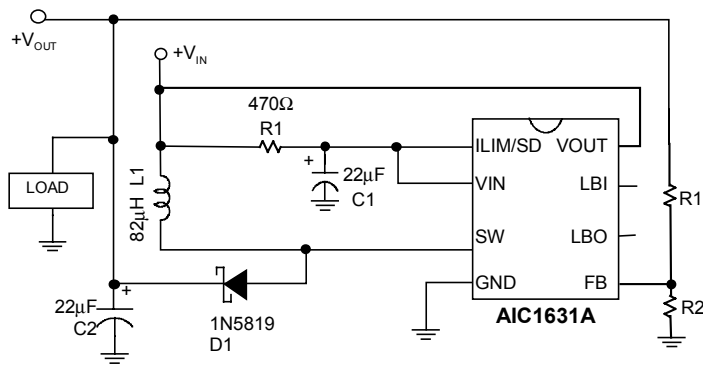
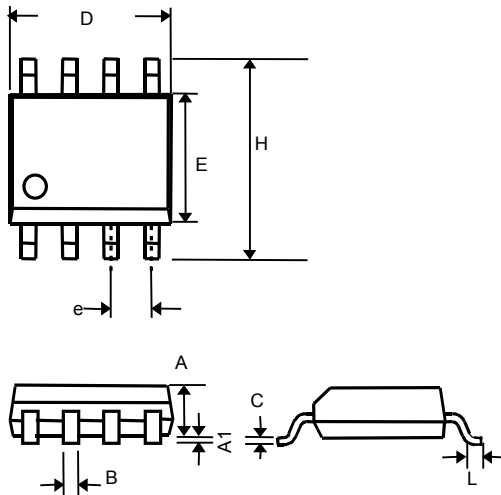
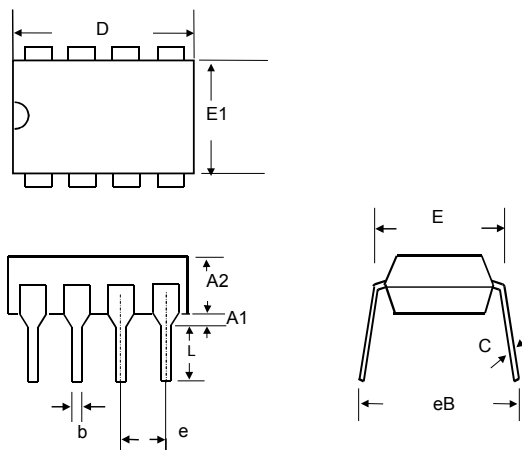

Fig.7 Adjustable Output Voltage Step-Up Converter

PHYSICAL DIMENSION
● 8 LEAD PLASTIC SO (unit: mm)

SYMBOL	MIN	MAX
A	1.35	1.75
A1	0.10	0.25
B	0.33	0.51
C	0.19	0.25
D	4.80	5.00
E	3.80	4.00
e	1.27(TYP)	
H	5.80	6.20
L	0.40	1.27

● 8 LEAD PLASTIC DIP (unit: mm)

SYMBOL	MIN	MAX
A1	0.381	—
A2	2.92	4.96
b	0.35	0.56
C	0.20	0.36
D	9.01	10.16
E	7.62	8.26
E1	6.09	7.12
e	2.54 (TYP)	
eB	—	10.92
L	2.92	3.81