



FEATURES

- Continuous 3.3V Output from Three Inputs.
- Complete Power Management Solution.
- VCC, VSBY Regulator Supplies 500mA Output.
- Built-in Hysteresis When Selecting Input Supplies.
- Drive Control Signal for External VAUX Switch.
- Output can be Forced Higher than Input (Off-State).

APPLICATIONS

- Desktop Computers.
- PCI Adapter Cards with Wake-On-LAN.
- Network Interface Cards (NICs).
- Multi Power System.
- System with Standby Capabilities.

TYPICAL APPLICATION CIRCUIT

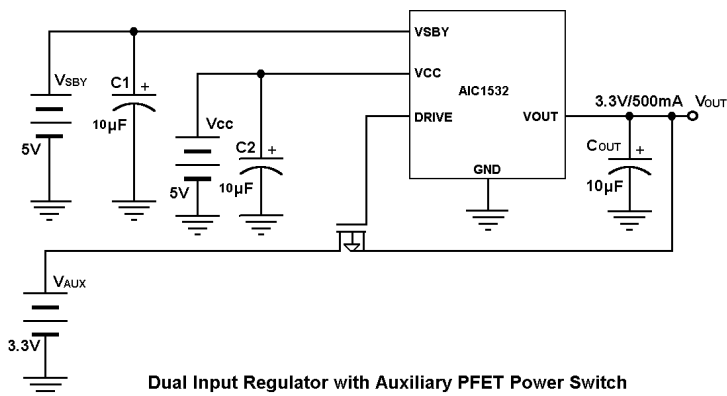

DESCRIPTION

AIC1532 is a dual input regulator with VAUX drive control capable of delivering 3.3V/500mA continuously. The output power is provided from three independent input voltage sources on a prioritized basis. Power is always taken in priority using the following order VCC, VSBY, and VAUX .

AIC1532 meets Intel's " Instantly Available " power requirements which follows the "Advanced Configuration and Power Interface" (ACPI) standards. When either VCC or VSBY is present, the device automatically enables the regulator and produces a stable 3.3V output VOUT. When only VAUX (3.3V) is present, the drive control output will turn-on an external PMOS switch from an auxiliary 3.3V supply VAUX to VOUT.

The IC also prevents excessive current from flowing VOUT to either input voltage or ground when the output voltage is bigger than the input voltage.

All the necessary control circuitry needed to provide a smooth and automatic transition between all the three supplies has been incorporated. This allows both VCC and VSBY to be dynamically switched without loss of output voltage.

ORDERING INFORMATION

AIC1532 CX
 PACKAGE TYPE
 N: PLASTIC DIP
 S: SMALL OUTLINE

ORDER NUMBER	PIN CONFIGURATION
AIC1532CN AIC1532CN (PLASTIC DIP)	TOP VIEW
AIC1532CS AIC1532CS (PLASTIC SO)	

**ABSOLUTE MAXIMUM RATINGS**

V_{CC} , V_{SBY} Input Voltage	7.0V
V_{AUX} Input Voltage	5.0V
V_{OUT} Output Voltage	5.0V
Operating Temperature Range	-40°C~85°C
Storage Temperature Range	-65°C ~ 150°C

ELECTRICAL CHARACTERISTICS ($V_{IN}=5V$, $T_a=25^\circ C$, unless otherwise specified.)

PARAMETERS	CONDITIONS	MIN.	TYP.	MAX.	UNIT
Regulated Output Voltage	$0mA < I_{LOAD} < 500mA$	3.135	3.300	3.465	V
Regulated Output Current		500			mA
Output Voltage Load Regulation	V_{CC} selected $I_{LOAD}=50mA \sim 500mA$ V_{SBY} selected $I_{LOAD}=50mA \sim 500mA$		20		mV
Output Voltage Line Regulation	$V_{CC}=4.5V \sim 5.5V$, $I_{LOAD}=5mA$		2		mV
V_{CC} Select Voltage			4.50	4.60	
V_{CC} Deselect Voltage		3.90	4.10		V
Hysteresis Voltage			0.40		
V_{CC} Supply Current	V_{CC} selected, $I_{LOAD}=0mA$ $V_{CCDES} > V_{CC} > V_{OUT}$		1.50	3.00	mA
V_{SBY} Supply Current	V_{SBY} selected, $I_{LOAD}=0mA$		1.50	3.00	mA
V_{CC} Pin Reverse Leakage	$V_{CC} = 0V$, $V_{SBY} = 5V$		10	100	μA
V_{SBY} Pin Reverse Leakage	$V_{CC} = 5V$, $V_{SBY} = 0V$		10	10	μA
Ground Current	$V_{CC}/SBY=5V$, $I_{LOAD} = 0mA$ $V_{CC}/SBY=5V$, $I_{LOAD} = 500mA$		1.50 3.00	3.00 6.00	mA
Short Circuit Current	$V_{CC}/SBY=5V$, $V_{OUT}=0V$		2000		mA
V_{DRIVE} High Voltage	V_{CC} or V_{SBY} selected	3.75	4.00		V
Drive delay	Drive High Delay Drive Low Delay		5.0 0.5		μS
Drive Pin Current limit	$V_{DRIVE}=1V$, $V_{CC}=5V$	0.5	6.0	25.0	mA



■ BLOCK DIAGRAM

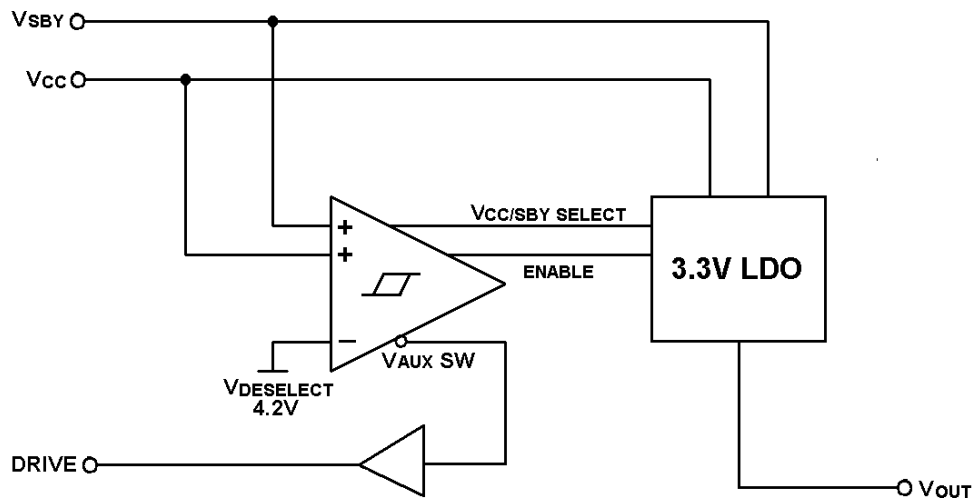

■ PIN DESCRIPTION

PIN 1: VSBY - Standby supply voltage (5V) input for 3.3V regulator when VCC falls below 4.3V. Some NICs that operate in "Wake-On-LAN" mode get a 5V standby through a cable that connects directly to a specific header on the Motherboard.

PIN 2: VCC - Primary supply voltage (5V) input for 3.3V regulator.

PIN 3: VOUT - 3.3V regulated output voltage when either VCC or VSBY is present. When only VAUX (3.3V) is present, VOUT voltage comes from VAUX through an internal low impedance switch.

PIN 4: DRIVE - Signal for controlling external auxiliary switch. Active Low when internal regulator is disabled.

PIN 5-8: GND - Negative reference for all voltages.



■ PHYSICAL DIMENSIONS

● 8 LEAD PLASTIC SO (unit: mm)

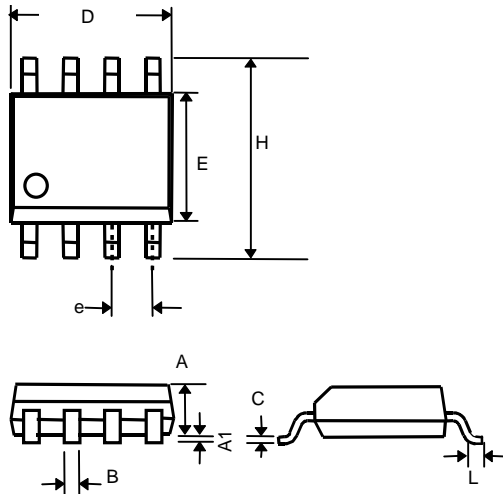

SYMBOL	MIN	MAX
A	1.35	1.75
A1	0.10	0.25
B	0.33	0.51
C	0.19	0.25
D	4.80	5.00
E	3.80	4.00
e	1.27(TYP)	
H	5.80	6.20
L	0.40	1.27

● 8 LEAD PLASTIC DIP (unit: mm)

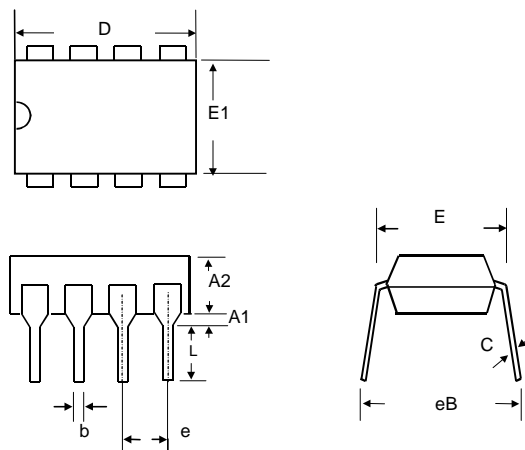

SYMBOL	MIN	MAX
A1	0.381	—
A2	2.92	4.96
b	0.35	0.56
C	0.20	0.36
D	9.01	10.16
E	7.62	8.26
E1	6.09	7.12
e	2.54 (TYP)	
eB	—	10.92
L	2.92	3.81