

## High-Efficiency, 40V Step-Up WLED Bias Supplies

### FEATURES

- High-Efficiency DC/DC WLED Bias Supply
- Internal 40V, 0.55Ω Power MOSFET
- Up to 10 WLEDs per String
- 500mA Peak Current
- Supports Analog and PWM LED Dimming
- Integrated Over-Voltage Protection (OVP)
- Thermal Shutdown
- Cycle-by-Cycle Over Current Protection
- Tiny SOT23-6 Package

### APPLICATIONS

- TFT LCD Displays
- Smart Phones
- Portable Media Players
- GPS/Personal Navigation Devices

### GENERAL DESCRIPTION

The ACT6359 step-up DC/DC converter drives white LEDs with an externally programmable constant current. This device features an integrated, 40V power MOSFET that is capable of driving up to ten white LEDs in series, providing inherent current matching for uniform brightness. WLED brightness adjustment is easily achieved via simple external circuitry, which accepts either a PWM or an analog dimming control signal.

The ACT6359 features a variety of protection circuits, including integrated over voltage protection (OVP), cycle-by-cycle current limiting, and thermal shutdown protection circuitry.

The ACT6359 has a 500mA current limit, and is available in a small 6-pin SOT23-6 package.

### SIMPLIFIED APPLICATION CIRCUIT

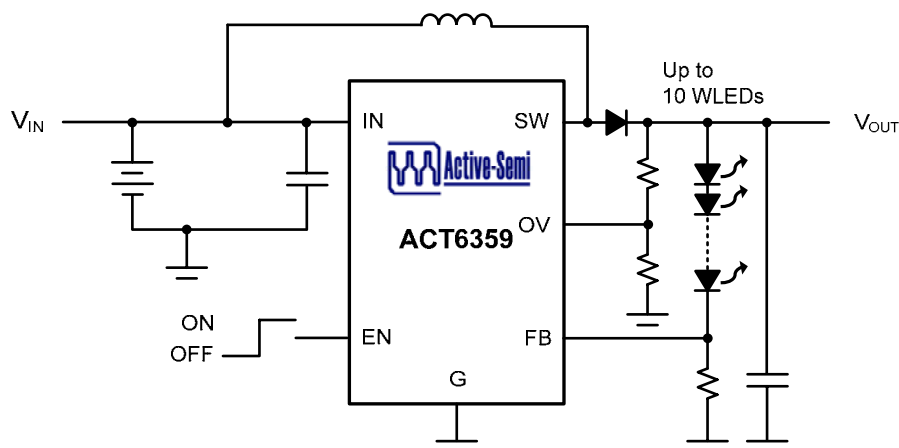

## ORDERING INFORMATION

PART NUMBER	CURRENT LIMIT	TEMPERATURE RANGE	PACKAGE	PINS	PACKAGING
ACT6359US-T	0.5A	-40°C to 85°C	SOT23-6	6	TAPE & REEL

## PIN CONFIGURATION

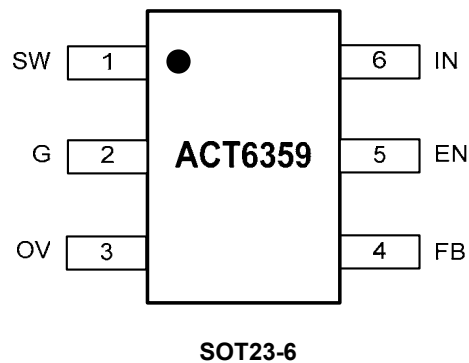

## PIN DESCRIPTIONS

PIN	NAME	DESCRIPTION
1	SW	Switch Output. Connect this pin to the inductor and the Schottky diode.
2	G	Ground
3	OV	Over Voltage Protection Input. The IC is automatically disabled when the voltage at this pin exceeds 1.21V. Connect OV to the center point of a resistive voltage divider connected across the LED string.
4	FB	Feedback Input. Connect this pin to the cathode of the bottom LED, and a current feedback resistor between this pin and G to set the LED bias current.
5	EN	Enable Control. Drive to a logic high to enable the device. Connect to a logic low to disable the device. EN should not be left floating; connect EN to IN when unused.
6	IN	Supply Input

**ABSOLUTE MAXIMUM RATINGS<sup>①</sup>**

PARAMETER	VALUE	UNIT
SW to G	-0.3 to 42	V
IN, EN to G	-0.3 to 6	V
FB, OV to G	-0.3 to $V_{IN} + 0.3$	V
Continuous SW Current	Internally Limited	
Junction to Ambient Thermal Resistance ( $\theta_{JA}$ )	200	°C/W
Maximum Power Dissipation	0.727	W
Operating Junction Temperature	-40 to 150	°C
Storage Temperature	-55 to 150	°C
Lead Temperature (Soldering, 10 sec)	300	°C

①: Do not exceed these limits to prevent damage to the device. Exposure to absolute maximum rating conditions for long periods may affect device reliability.

## ELECTRICAL CHARACTERISTICS

( $V_{IN} = V_{EN} = 3.3V$ ,  $T_A = 25^\circ C$ , unless otherwise specified.)

PARAMETER	TEST CONDITIONS	MIN	TYP	MAX	UNIT
Power Switch Voltage Rating				40	V
Input Voltage		2.6		5.5	V
Under Voltage Lockout Threshold	$V_{IN}$ Rising	2.1	2.25	2.45	V
Under Voltage Lockout Hysteresis			80		mV
Supply Current	Not Switching		0.1	0.25	mA
	Switching		0.25	0.5	
Supply Current in Shutdown	EN = G		0.1	10	$\mu A$
Maximum On Time	$V_{IN} = 3.3V$	2.6	4.0	5.8	$\mu s$
Maximum On Time Constant (K)	$K = t_{MAXON} \times V_{IN}$		13.2		$\mu s \times V$
Minimum Off Time		220	320	450	ns
FB Feedback Voltage	$V_{EN} \geq 1.8V$	275	290	305	mV
FB Input Current	$V_{FB} = 1V$		0	200	nA
Switch Current Limit		320	500	750	mA
Switch On Resistance			0.55	0.9	$\Omega$
Switch Leakage Current	$V_{SW} = 38V$ , EN = G		0	10	$\mu A$
Over Voltage Protection Threshold	$V_{OV}$ Rising	1.11	1.21	1.31	V
OV Input Current	$V_{OV} = 1.5V$		0	200	nA
EN Logic High Threshold		1.4			V
EN Logic Low Threshold				0.4	V
EN Input Current	$V_{EN} = 0V, 3.3V$		18	36	$\mu A$
Thermal Shutdown Temperature			160		$^\circ C$
Thermal Shutdown Hysteresis			20		$^\circ C$

## FUNCTIONAL BLOCK DIAGRAM

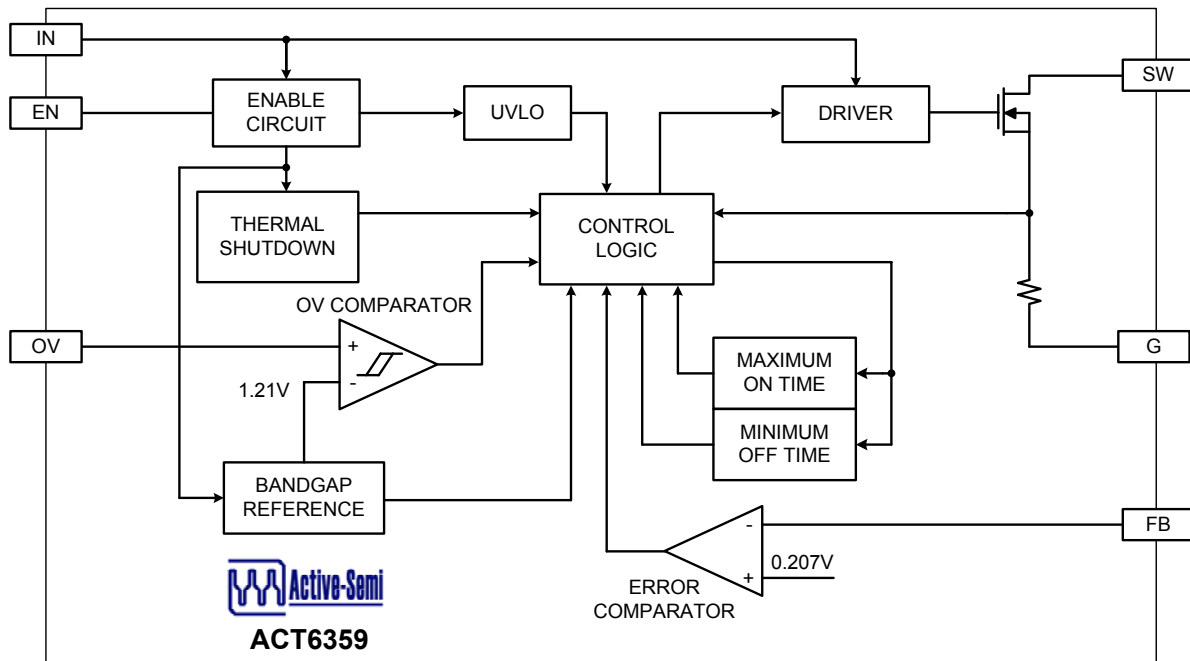

### Control Scheme

The ACT6359 uses a minimum off-time, current-mode control scheme to achieve excellent performance under high duty-cycle operating conditions. This control scheme initiates a switching cycle only when needed to maintain output voltage regulation, resulting in very high efficiency operation.

During each switching cycle, the N-channel power MOSFET turns on, increasing the inductor current. The switching cycle terminates when either the inductor current reaches the current limit (500mA) or when the cycle lasts longer than the maximum on-time of 4 $\mu$ s. Once the MOSFET turns off, it remains off for at least the minimum off-time of 320ns, then another switching begins when the error comparator detects that the output is falling out of regulation again.

### Over Voltage Protection

The ACT6359 includes internal over-voltage protection circuitry that monitors the OV pin voltage. Over-voltage protection is critical when one of the LEDs in the LED string fails as an open circuit. When this happens the feedback voltage drops to zero, and the control switches at maximum on time causing the output voltage to keep rising until it exceeds the maximum voltage rating of the power

MOSFET. The over-voltage protection circuit detects this condition and switching ceases if the voltage at the OV pin reaches 1.21V.

To set the maximum output voltage, connect a resistor divider from the output node to G, with center tap at OV, and select the two resistors with the following equation:

$$R_{OV2} = R_{OV1} \times \left[ \left( \frac{V_{OV}}{1.21V} \right) - 1 \right]$$

where  $V_{OV}$  is the over voltage detection threshold,  $R_{OV1}$  is the resistor between OV and G, and  $R_{OV2}$  is the resistor from the output to the OV pin. As a first estimate, the OV threshold can often be set to 4V times the number of LEDs in the string.

### Setting the LED Current

The LED current is programmed by appropriate selection of the feedback resistor  $R_{FB}$  connected between FB and G. To set the LED current, choose the resistor according to the equation:

$$R_{CS} = \frac{V_{FB}}{I_{LED}}$$

where  $V_{FB}$  is the FB feedback voltage (typically 290mV at  $V_{EN} = 3.3V$ ) and  $I_{LED}$  is the desired maximum LED current.

## Capacitor Selection

The ACT6359 requires only a tiny 0.47 $\mu$ F output capacitor for most applications. For circuits driving 6 or fewer LEDs, a 4.7 $\mu$ F input capacitor is generally suitable. For circuits driving more than 6 LEDs, a 10 $\mu$ F input capacitor may be required.

When choosing a larger inductor which results in CCM operation, stability and ripple can be improved by adding a small feed forward capacitor from OUT to FB. About 3000pF is a good starting point for most applications, although a larger value can be used to achieve best results in applications with 6 or fewer LEDs.

Ceramic capacitors are recommended for most applications. For best performance, use X5R and X7R type ceramic capacitors, which possess less degradation in capacitance over voltage and temperature.

## Diode Selection

The ACT6359 requires a Schottky diode as the rectifier. Select a low forward voltage drop Schottky diode with forward current ( $I_F$ ) rating that exceeds the peak current limit (500mA) and a peak repetitive reverse voltage ( $V_{RRM}$ ) rating that exceeds the maximum output voltage, typically set by the OV threshold.

## Shutdown

The ACT6359 features a low-current shutdown mode. In shutdown mode, the control circuitry is disabled and the quiescent supply current drops to less than 1 $\mu$ A. To disable the IC, simply drive EN to a logic low. To enable the ICs, drive EN to a logic high or connect it to the input supply.

## Low Input Voltage Applications

In applications that have low input voltage range, such as those powered from 2-3 AA cells, the ACT6359 may still be used if there is a suitable system supply (such as 3.3V) available to power the controller. In such an application, the inductor may be connected directly to the battery, while the IC power is supplied by the system supply.

## TYPICAL PERFORMANCE CHARACTERISTICS

( $V_{IN} = 3.6V$ ,  $T_A = 25^\circ C$ , unless otherwise specified.)

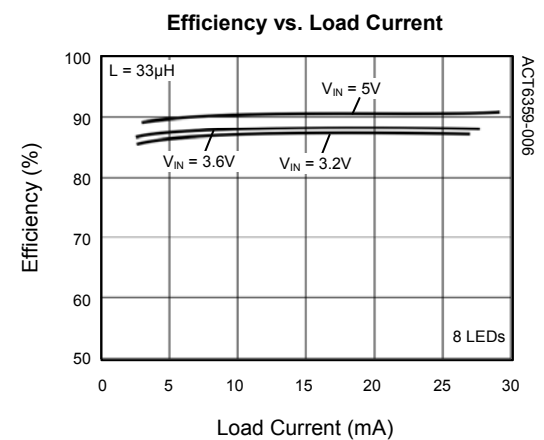
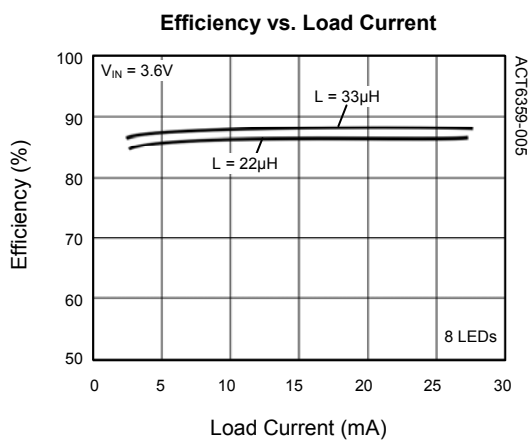
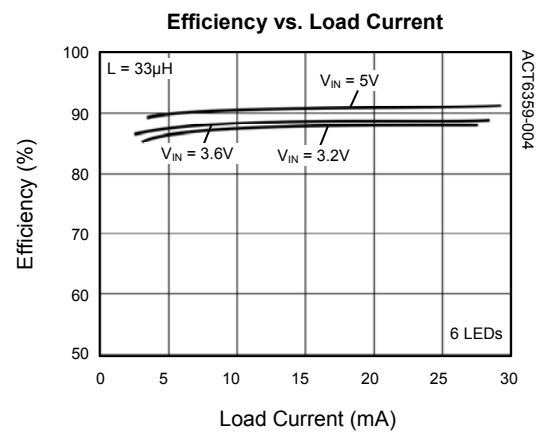
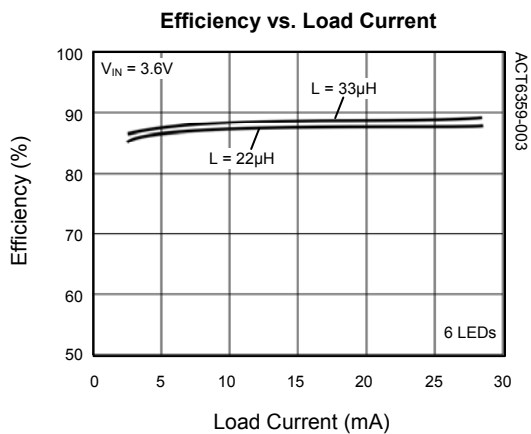
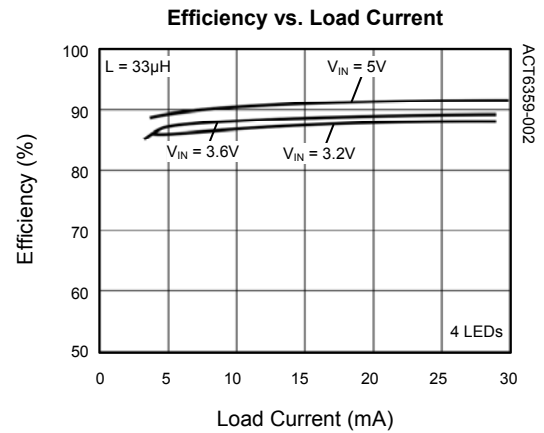
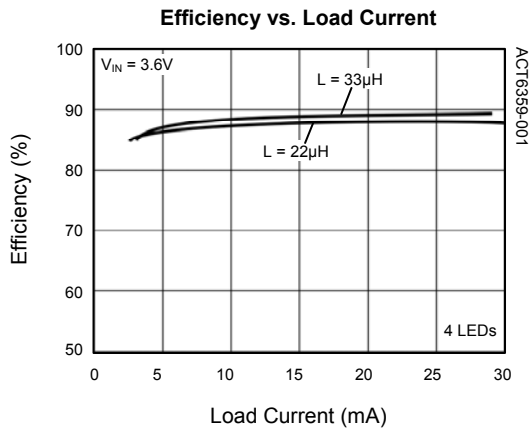

## PACKAGE OUTLINE

### SOT23-6 PACKAGE OUTLINE AND DIMENSIONS

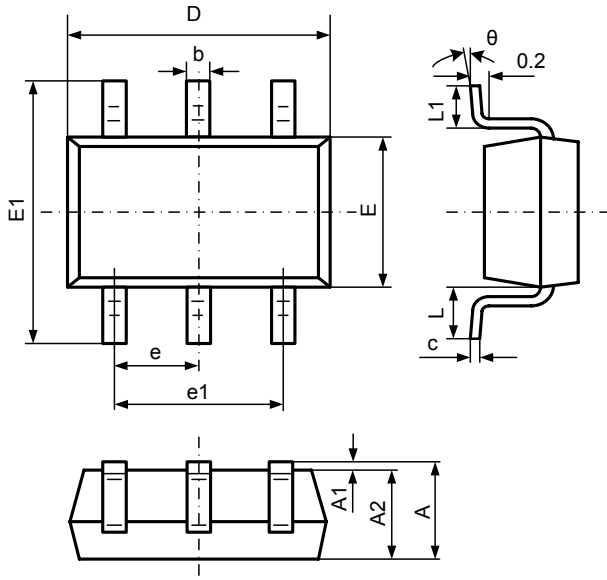

SYMBOL	DIMENSION IN MILLIMETERS		DIMENSION IN INCHES	
	MIN	MAX	MIN	MAX
A	1.050	1.250	0.041	0.049
A1	0.000	0.100	0.000	0.004
A2	1.050	1.150	0.041	0.045
b	0.300	0.500	0.012	0.020
c	0.100	0.200	0.004	0.008
D	2.820	3.020	0.111	0.119
E	1.500	1.700	0.059	0.067
E1	2.650	2.950	0.104	0.116
e	0.950 TYP		0.037 TYP	
e1	1.800	2.000	0.071	0.079
L	0.700 REF		0.028 REF	
L1	0.300	0.600	0.012	0.024
θ	0°	8°	0°	8°

Active-Semi, Inc. reserves the right to modify the circuitry or specifications without notice. Users should evaluate each product to make sure that it is suitable for their applications. Active-Semi products are not intended or authorized for use as critical components in life-support devices or systems. Active-Semi, Inc. does not assume any liability arising out of the use of any product or circuit described in this datasheet, nor does it convey any patent license.

Active-Semi and its logo are trademarks of Active-Semi, Inc. For more information on this and other products, contact [sales@active-semi.com](mailto:sales@active-semi.com) or visit <http://www.active-semi.com>. For other inquiries, please send to:

1270 Oakmead Parkway, Suite 310, Sunnyvale, California 94085-4044, USA