

DATA SHEET

80C550/83C550/87C550

80C51 8-bit microcontroller family

4K/128 OTP/ROM/ROMless, 8 channel 8 bit A/D,
watchdog timer

Product specification
Supersedes data of 1998 Jan 19
IC20 Data Handbook

1998 May 01

80C51 8-bit microcontroller family**4K/128 OTP/ROM/ROMless, 8 channel 8 bit A/D, watchdog timer****80C550/83C550/87C550****DESCRIPTION**

The Philips 8XC550 is a high-performance microcontroller fabricated with Philips high-density CMOS technology. This Philips CMOS technology combines the high speed and density characteristics of HMOS with the low power attributes of CMOS. Philips epitaxial substrate minimizes latch-up sensitivity. The CMOS 8XC550 has the same instruction set as the 80C51.

The 8XC550 contains a 4k × 8 EPROM (87C550)/ROM (83C550)/ROMless (80C550 has no program memory on-chip), a 128 × 8 RAM, 8 channels of 8-bit A/D, four 8-bit ports (port 1 is input only), a watchdog timer, two 16-bit counter/timers, a seven-source, two-priority level nested interrupt structure, a serial I/O port for either multi-processor communications, I/O expansion or full duplex UART, and an on-chip oscillator and clock circuits.

In addition, the 8XC550 has two software selectable modes of power reduction—idle mode and power-down mode. The idle mode freezes the CPU while allowing the RAM, timers, serial port, and interrupt system to continue functioning. The power-down mode saves the RAM contents but freezes the oscillator, causing all other chip functions to be inoperative.

FEATURES

- 80C51 based architecture
 - 4k × 8 EPROM (87C550)/ROM (83C550)
 - 128 × 8 RAM
 - Eight channels of 8-bit A/D
 - Two 16-bit counter/timers
 - Watchdog timer
 - Full duplex serial channel
 - Boolean processor
- Memory addressing capability
 - 64k ROM and 64k RAM
- Power control modes:
 - Idle mode
 - Power-down mode
- CMOS and TTL compatible
- One speed range at $V_{CC} = 5V \pm 10\%$
 - 3.5 to 16MHz
- Extended temperature ranges
- OTP package available

ORDERING INFORMATION

ROMless	ROM	EPROM		TEMPERATURE RANGE °C AND PACKAGE ¹	FREQ MHz	DRAWING NUMBER
P80C550EBP N	P83C550EBP N	P87C550EBP N	OTP	0 to +70, Plastic Dual In-Line Package	3.5 to 16	SOT129-1
P80C550EBA A	P83C550EBA A	P87C550EBA A	OTP	0 to +70, Plastic Leaded Chip Carrier	3.5 to 16	SOT187-2
P80C550EFA A	P83C550EFA A	P87C550EFA A	OTP	-40 to +85, Plastic Leaded Chip Carrier	3.5 to 16	SOT187-2

NOTES:

1. OTP = One Time Programmable EPROM.

80C51 8-bit microcontroller family

4K/128 OTP/ROM/ROMless, 8 channel 8 bit A/D, watchdog timer

80C550/83C550/87C550

BLOCK DIAGRAM

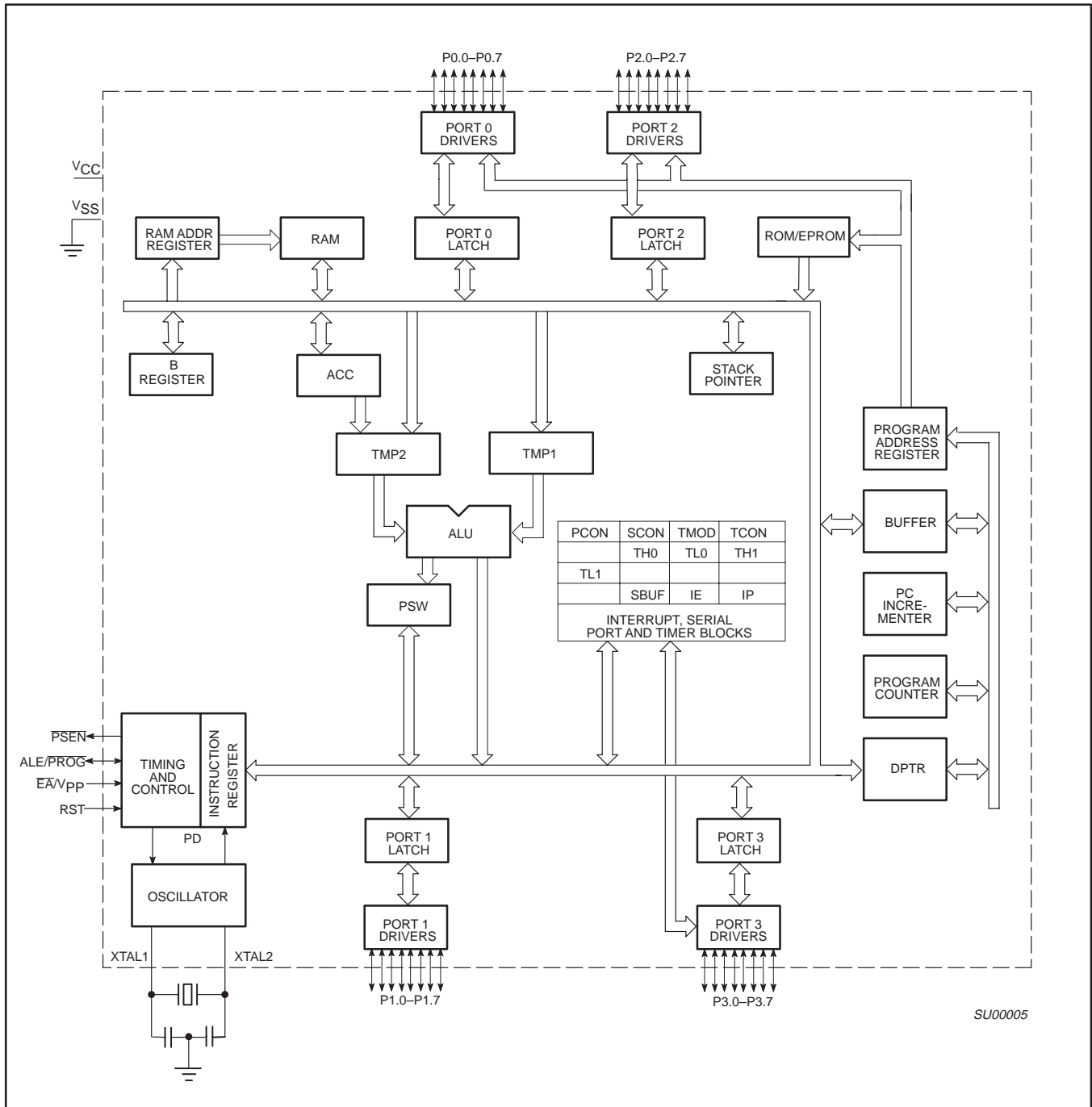

SU00005

80C51 8-bit microcontroller family

4K/128 OTP/ROM/ROMless, 8 channel 8 bit A/D, watchdog timer

80C550/83C550/87C550

PIN CONFIGURATIONS

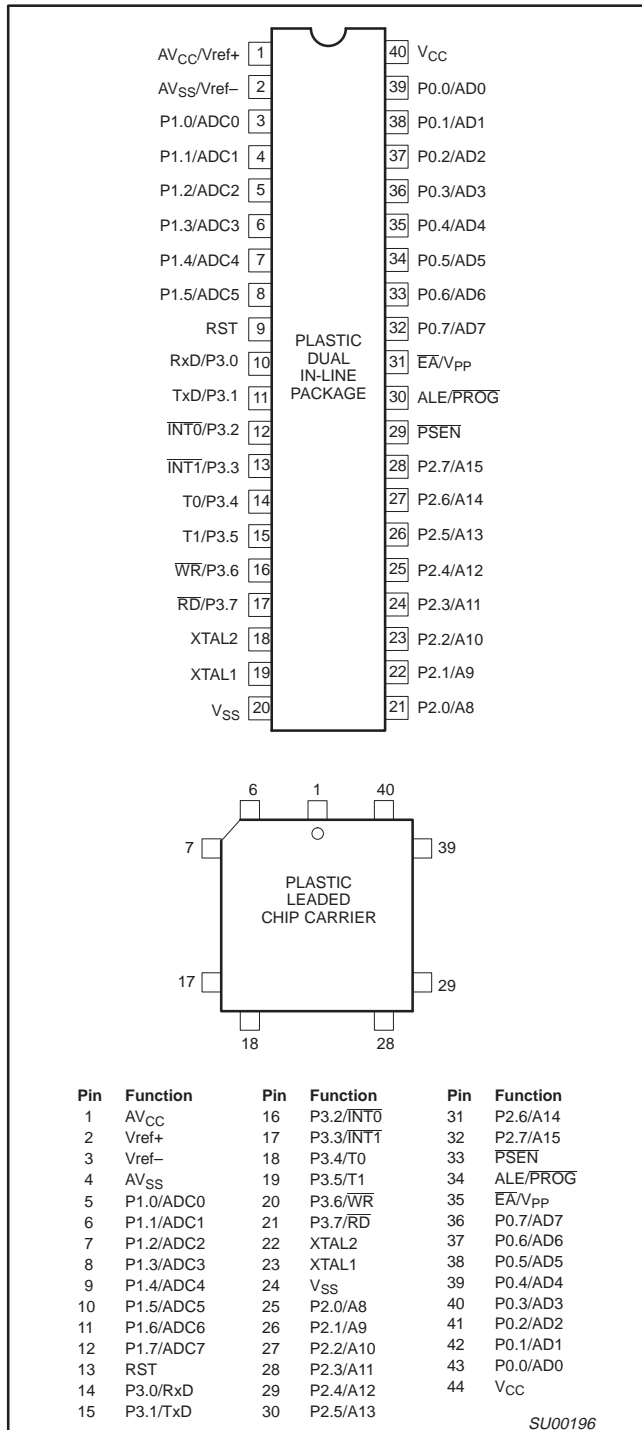

80C51 8-bit microcontroller family

80C550/83C550/87C550

4K/128 OTP/ROM/ROMless, 8 channel 8 bit A/D, watchdog timer

PIN DESCRIPTION

MNEMONIC	PIN NO.		TYPE	NAME AND FUNCTION
	DIP	LCC		
V _{SS}	20	24	I	Ground: 0V reference.
V _{CC}	40	44	I	Power Supply: This is the power supply voltage for normal, idle, and power-down operation.
AV _{CC}	1	1	I	Analog Power Supply: Analog supply voltage.
AV _{SS}	2	4	I	Analog Ground: Analog 0V reference.
V _{ref+} V _{ref-}	2 3	2 3	I I	V_{ref}: A/D converter reference level inputs. Note that these references are combined with AV _{CC} and AV _{SS} in the 40-pin DIP package.
P0.0–P0.7	39–32	43–36	I/O	Port 0: Port 0 is an open-drain, bidirectional I/O port. Port 0 pins that have 1s written to them float and can be used as high-impedance inputs. Port 0 is also the multiplexed low-order address and data bus during accesses to external program and data memory. In this application, it uses strong internal pull-ups when emitting 1s. Port 0 also outputs the code bytes during program verification in the S87C550. External pull-ups are required during program verification.
P1.0–P1.7	3–8	5–12	I	Port 1: Port 1 is an 8-bit input only port (6-bit in the DIP package; bits P1.6 and P1.7 are not implemented). Port 1 digital input can be read out any time.
ADC0–ADC7	3–8	5–12	I	ADCx: Inputs to the analog multiplexer input of the 8-bit A/D. There are only six A/D inputs in the DIP package.
P2.0–P2.7	21–28	25–32	I/O	Port 2: Port 2 is an 8-bit bidirectional I/O port with internal pull-ups. Port 2 pins that have 1s written to them are pulled high by the internal pull-ups and can be used as inputs. As inputs, port 2 pins that are externally being pulled low will source current because of the internal pull-ups. (See DC Electrical Characteristics: I _{IL}). Port 2 emits the high-order address byte during fetches from external program memory and during accesses to external data memory that use 16-bit addresses (MOVX @DPTR). In this application, it uses strong internal pull-ups when emitting 1s. During accesses to external data memory that use 8-bit addresses (MOV @Ri), port 2 emits the contents of the P2 special function register.
P3.0–P3.7	10–17	14–21	I/O	Port 3: Port 3 is an 8-bit bidirectional I/O port with internal pull-ups. Port 3 pins that have 1s written to them are pulled high by the internal pull-ups and can be used as inputs. As inputs, port 3 pins that are externally being pulled low will source current because of the pull-ups. (See DC Electrical Characteristics: I _{IL}). Port 3 also serves the special features of the SC80C51 family, as listed below:
	10	14	I	RxD (P3.0): Serial input port
	11	15	O	TxD (P3.1): Serial output port
	12	16	I	INT0 (P3.2): External interrupt
	13	17	I	INT1 (P3.3): External interrupt
	14	18	I	T0 (P3.4): Timer 0 external input
	15	19	I	T1 (P3.5): Timer 1 external input
	16	20	O	WR (P3.6): External data memory write strobe
	17	21	O	RD (P3.7): External data memory read strobe
RST	9	13	I	Reset: A high on this pin for two machine cycles while the oscillator is running, resets the device. An internal diffused resistor to V _{SS} permits a power-on reset using only an external capacitor to V _{CC} .
ALE/PROG	30	34	I/O	Address Latch Enable/Program Pulse: Output pulse for latching the low byte of the address during an access to external memory. In normal operation, ALE is emitted at a constant rate of 1/6 the oscillator frequency, and can be used for external timing or clocking. Note that one ALE pulse is skipped during each access to external data memory. This pin is also the program pulse input (PROG) during EPROM programming.
PSEN	29	33	O	Program Store Enable: The read strobe to external program memory. When the device is executing code from the external program memory, PSEN is activated twice each machine cycle, except that two PSEN activations are skipped during each access to external data memory. PSEN is not activated during fetches from internal program memory.
EA/V _{PP}	31	35	I	External Access Enable/Programming Supply Voltage: EA must be externally held low to enable the device to fetch code from external program memory locations 0000H to 0FFFH. If EA is held high, the device executes from internal program memory unless the program counter contains an address greater than 0FFFH. For the 80C550 ROMless part, EA must be held low for the part to operate properly. This pin also receives the 12.75V programming supply voltage (V _{PP}) during EPROM programming.
XTAL1	19	23	I	Crystal 1: Input to the inverting oscillator amplifier and input to the internal clock generator circuits.
XTAL2	18	22	O	Crystal 2: Output from the inverting oscillator amplifier.

80C51 8-bit microcontroller family

4K/128 OTP/ROM/ROMless, 8 channel 8 bit A/D, watchdog timer

80C550/83C550/87C550

Table 1. 8XC550 Special Function Registers

SYMBOL	DESCRIPTION	DIRECT ADDRESS	BIT ADDRESS, SYMBOL, OR ALTERNATIVE PORT FUNCTION								RESET VALUE
			MSB				LSB				
ACC*	Accumulator	E0H	E7	E6	E5	E4	E3	E2	E1	E0	00H
ADAT#	A/D result	C6H									xxH
ADCON#	A/D control	C5H	-	-	-	ADCI	ADCS	AADR2	AADR1	AADR0	xxx00000B
B*	B register	F0H	F7	F6	F5	F4	F3	F2	F1	F0	00H
DPTR:	Data pointer (2 bytes): High byte Low byte	83H									00H
DPH DPL		82H	BF	BE	BD	BC	BB	BA	B9	B8	00H
IP*#	Interrupt priority	B8H	-	PWD	PAD	PS	PT1	PX1	PT0	PX0	x0000000B
			AF	AE	AD	AC	AB	AA	A9	A8	
IE*#	Interrupt enable	A8H	EA	EWD	EAD	ES	ET1	EX1	ET0	EX0	00H
P0*	Port 0	80H	87	86	85	84	83	82	81	80	FFH
P1*	Port 1	90H	97	96	95	94	93	92	91	90	FFH
P2*	Port 2	A0H	A7	A6	A5	A4	A3	A2	A1	A0	FFH
P3*	Port 3	B0H	B7	B6	B5	B4	B3	B2	B1	B0	FFH
PCON#	Power control	87H	SMOD	SIDL	-	-	GF1	GF0	PD	IDL	00xx0000B
			D7	D6	D5	D4	D3	D2	D1	D0	
PSW*	Program status word	D0H	CY	AC	F0	RS1	RS0	OV	-	P	00H
SBUF	Serial data buffer	99H									xxH
			9F	9E	9D	9C	9B	9A	99	98	
SCON*	Serial port control	98H	SM0	SM1	SM2	REN	TB8	RB8	TI	RI	00H
SP	Stack pointer	81H									07H
			8F	8E	8D	8C	8B	8A	89	88	00H
TCON*	Timer counter/control	88H	TF1	TR1	TF0	TR0	IE1	IT1	IE0	IT0	00H
TMOD	Timer/counter mode	89H	GATE	C/T	M1	M0	GATE	C/T	M1	M0	00H
TH0	Timer 0 high byte	8CH									00H
TH1	Timer 1 high byte	8DH									00H
TL0	Timer 0 low byte	8AH									00H
TL1	Timer 1 low byte	8BH									00H
			C7	C6	C5	C4	C3	C2	C1	C0	
WDCON*#	Watchdog timer control	C0H	PRE2	PRE1	PRE0	-	-	WDRUN	WDTOF	WDMOD	000xx000B**
WDL#	Watchdog timer reload	C1H									FFH**
WFEED1#	Watchdog timer feed 1	C2H									xxH
WFEED2#	Watchdog timer feed 2	C3H									xxH

* SFRs are bit addressable.

SFRs are modified from or added to the 80C51 SFRs.

**This value is not valid for a masked ROM part (83C550) when running from internal memory ($\overline{EA} = 1$). See data sheet for details.

80C51 8-bit microcontroller family

80C550/83C550/87C550

4K/128 OTP/ROM/ROMless, 8 channel 8 bit A/D, watchdog timer

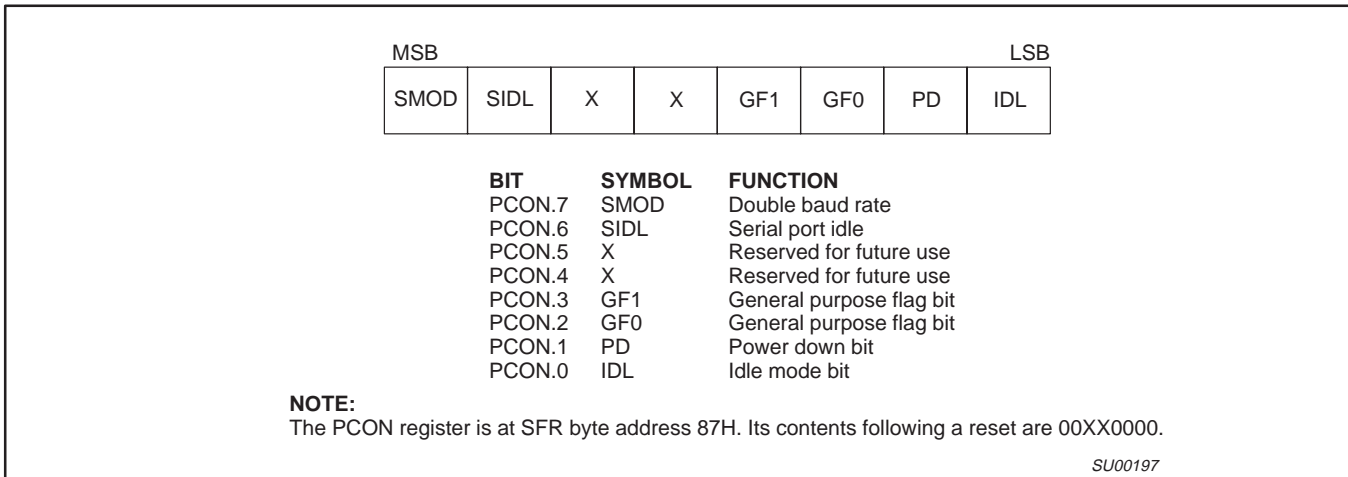

Figure 1. Power Control Register (PCON)

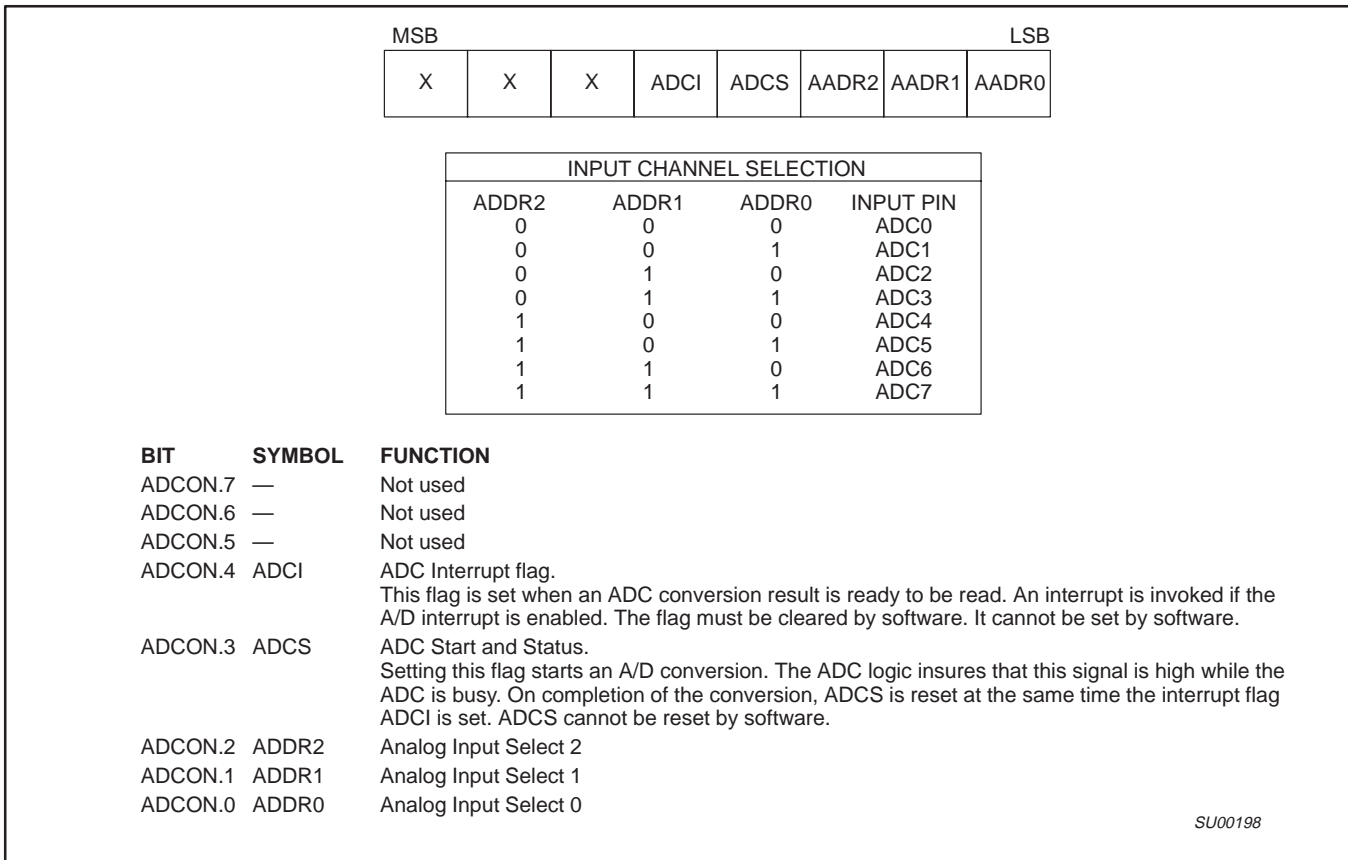

Figure 2. A/D Control Register (ADCON)

80C51 8-bit microcontroller family

4K/128 OTP/ROM/ROMless, 8 channel 8 bit A/D, watchdog timer

80C550/83C550/87C550

A/D CONVERTER

The analog input circuitry consists of an 8-input analog multiplexer and an analog-to-digital converter with 8-bit resolution. In the LCC package, the analog reference voltage and analog power supplies are connected via separate input pins; in the DIP package, Vref+ is combined with AVCC and Vref- is combined with AVSS. The analog inputs are alternate functions to port 1, which is an input only port. Digital input to port 1 can be read any time during an A/D conversion. Care should be exercised in mixing analog and digital signals on port 1, because cross talk from the digital input signals can degrade the A/D conversion accuracy of the analog input. An A/D conversion requires 40 machine cycles.

The A/D converter is controlled by the ADCON special function register. The input channel to be converted is selected by the analog multiplexer by setting ADCON register bits, ADDR2-ADDR0 (see Figure 2). These bits can only be changed when ADCI and ADCS are both low.

The completion of the 8-bit ADC conversion is flagged by ADCI in the ADCON register and the result is stored in the special function register ADAT.

An ADC conversion in progress is unaffected by a software ADC start. The result of a completed conversion remains unaffected provided ADCI remains at a logic 1. While ADCS is a logic 1 or ADCI is a logic 1, a new ADC START will be blocked and consequently lost. An A/D conversion in progress will be aborted when the idle or power-down mode is entered. The result of a completed conversion (ADCI = logic 1) remains unaffected when entering the idle mode, but will be lost if power-down mode is entered. See Figure 3 for the A/D input equivalent circuit.

The analog input pins ADC0-ADC7 may still be used as digital inputs. The analog input channel that is selected by the ADDR2-ADDR0 bits in ADCON cannot be used as a digital input. Reading the selected A/D channel as a digital input will always return a 1. The unselected A/D inputs may always be used as digital inputs.

On RESET the A/D port pins are set to the Digital mode and will work as a normal port and need no further initialization. To use the A/D converter a single byte should be written to ADCON which selects the A/D mux and concurrently sets the ADCS bit to start the A/D conversion. The 40 machine cycles of the A/D conversion include time for signal settling after the mux is selected and before the Sample and Hold procedure is completed.

The circuitry which disables the digital buffer from the port pin is updated at the start of an A/D conversion by setting the ADCS bit in ADCON. After powerup, problems will occur the first time that ADCON is written to if ADCS is not set; in this case, the digital signal disable registers contain random data and some of the 8 port pins will have their digital buffers disabled. When read, these disabled buffers will ignore their input and only return a 1. This condition will be corrected by writing a 1 to ADCS in ADCON which starts and A/D conversion.

Thus, there are two operating modes:

1. DIGITAL ONLY - No Analog inputs are used and ADCON is never written to. In this case pins ADC0-ADC7 are configured as digital inputs.
2. A/D CONVERTER USED - The input multiplexer select field must be written to and ADCS must be set in ADCON. This allows unselected A/D inputs to be used as digital inputs.

ADCON Register

MSB			LSB				
X	X	X	ADCI	SDCS	AADR2	AADR1	AADR0

ADCI	ADCS	Operation
0	0	ADC not busy, a conversion can be started.
0	1	ADC busy, start of a new conversion is blocked.
1	0	Conversion completed, start of a new is blocked.
1	1	Not possible.

INPUT CHANNEL SELECTION			
ADDR2	ADDR1	ADDR0	INPUT PIN
0	0	0	P1.0
0	0	1	P1.1
0	1	0	P1.2
0	1	1	P1.3
1	0	0	P1.4
1	0	1	P1.5
1	1	0	P1.6*
1	1	1	P1.7*

*Not present on 40-pin DIP versions.

Symbol	Position	Function
ADCI	ADCON.4	ADC interrupt flag. This flag is set when an ADC conversion is complete. If IE.5 = 1, an interrupt is requested when ADCI = 1. The ADCI flag must be cleared by software after A/D data is read, before the next conversion can begin.
ADCS	ADCON.3	ADC start and status. Setting this bit starts an A/D conversion. Once set, ADCS remains high throughout the conversion cycle. On completion of the conversion, it is reset at the same time the ADCI interrupt flag is set. ADCS cannot be reset by software.
AADR2	ADCON.2	Analog input selects.
AADR1	ADCON.1	Binary coded address
AADR0	ADCON.0	selects one of the five analog input port pins of P1 to be input to the converter. It can only be changed when ADCI and ADCS are both low. AADR2 is the most significant bit.

80C51 8-bit microcontroller family

4K/128 OTP/ROM/ROMless, 8 channel 8 bit A/D, watchdog timer

80C550/83C550/87C550

Sample A/D Routines

The following routines demonstrate two methods of operating the A/D converter. The first method uses polling to determine when the A/D conversion is complete. The second method uses the A/D interrupt to flag the end of conversion.

The routine ReadAD will start a read of the A/D channel identified by R7, and wait for the conversion to complete, polling the A/D interrupt flag. The result is returned in the accumulator.

```

ReadAD: MOV  A,#08h      ;Basic A/D start command.
        ORL  A,R7       ;Add channel # to be read.
        MOV  ADCON,A;    ;Start A/D.
ADLoop: MOV  A,ADCON     ;Get A/D status.
        JNB  ACC.4,ADLoop;Wait for ADCl (A/D ;finished).
        MOV  A,ADAT     ;Get conversion result
        MOV  ADCON,#0   ;Clear ADCl.
        RET
    
```

The routine StartAD will start a read of the A/D channel identified by R7 and exit back to the calling program. When the conversion is complete, the A/D interrupt occurs, calling the A/D interrupt service routine. The result of the conversion is returned in register R6.

```

StartAD: MOV  A,#08h      ;Basic A/D start command.
        ORL  A,R7       ;Add channel # to be read.
        MOV  ADCON,A;    ;Start A/D.
        RET
        .
        .
        .
        ORG  2Bh        ;A/D interrupt address.
ADInt:  MOV  R6,ADAT     ;Get conversion result.
        MOV  ADCON,#0   ;Clear ADCl.
        RETI
    
```

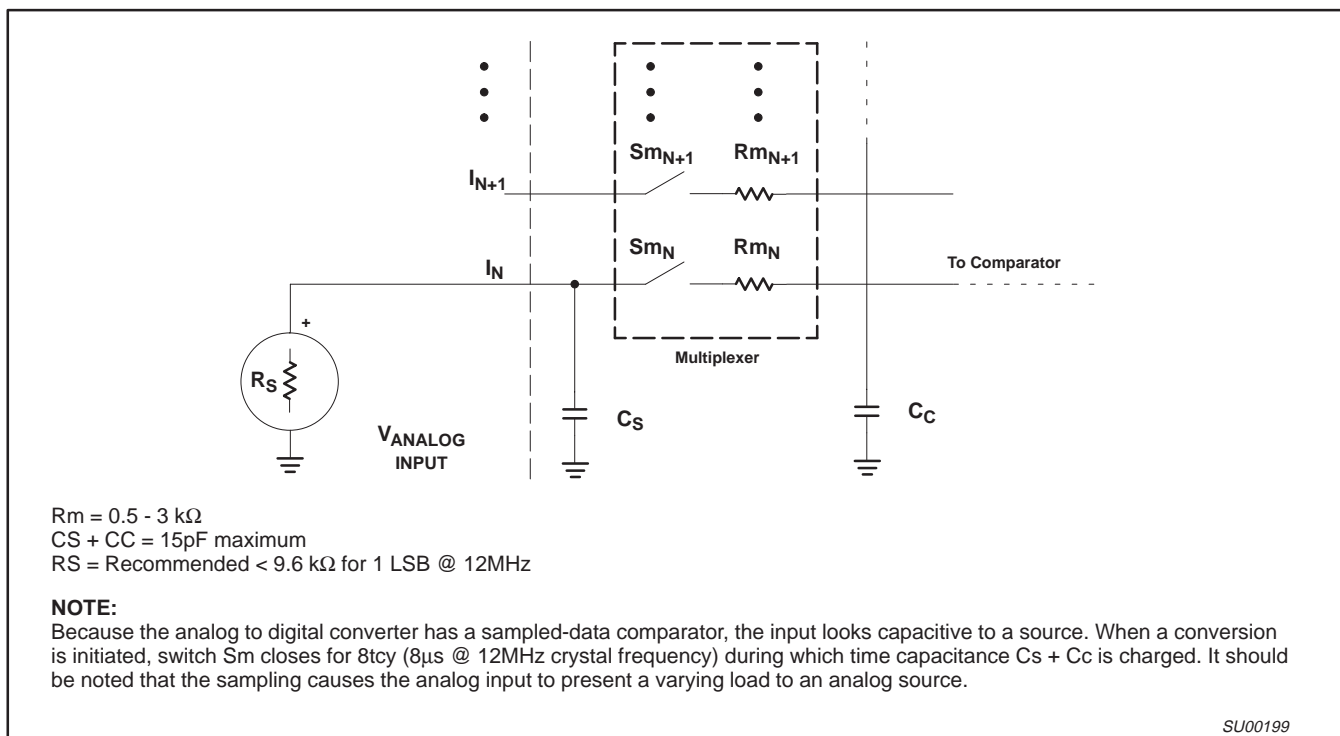

Figure 3. A/D Input: Equivalent Circuit

80C51 8-bit microcontroller family

4K/128 OTP/ROM/ROMless, 8 channel 8 bit A/D, watchdog timer

80C550/83C550/87C550

A/D CONVERTER PARAMETER DEFINITIONS

The following definitions are included to clarify some specifications given and do not represent a complete set of A/D parameter definitions.

Absolute Accuracy Error

Absolute accuracy error of a given output is the difference between the theoretical analog input voltage to produce a given output and the actual analog input voltage required to produce the same code. Since the same output code is produced by a band of input voltages, the "required input voltage" is defined as the midpoint of the band of input voltage that will produce that code. Absolute accuracy error not specified with a code is the maximum over all codes.

Nonlinearity

If a straight line is drawn between the end points of the actual converter characteristics such that zero offset and full scale errors are removed, then non-linearity is the maximum deviation of the code transitions of the actual characteristics from that of the straight line so constructed. This is also referred to as relative accuracy and also integral non-linearity.

Differential Non-Linearity

Differential non-linearity is the maximum difference between the actual and ideal code widths for the converter. The code widths are the differences expressed in LSB between the code transition points, as the input voltage is varied through the range for the complete set of codes.

Gain Error

Gain error is the deviation between the ideal and actual analog input voltage required to cause the final code transition to a full-scale output code after the offset error has been removed. This may sometimes be referred to as full scale error.

Offset Error

Offset error is the difference between the actual input voltage that causes the first code transition and the ideal value to cause the first code transition. This ideal value is 1/2 LSB above V_{ref-} .

Channel to Channel Matching

Channel to channel matching is the maximum difference between the corresponding code transitions of the actual characteristics taken from different channels under the same temperature, voltage and frequency conditions.

Crosstalk

Crosstalk is the measured level of a signal at the output of the converter resulting from a signal applied to one deselected channel.

Total Error

Maximum deviation of any step point from a line connecting the ideal first transition point to the ideal last transition point.

Relative Accuracy

Relative accuracy error is the deviation of the ADC's actual code transition points from the ideal code transition points on a straight line which connects the ideal first code transition point and the final code transition point, after nullifying offset error and gain error. It is generally expressed in LSBs or in percent of FSR.

WATCHDOG TIMER

The purpose of the watchdog timer is to reset the microcontroller within a reasonable amount of time if it enters an erroneous state, possibly due to a programming error, electrical noise, or RFI. When enabled, the watchdog circuit will generate a system reset if the user program fails to "feed" (or reload) the watchdog within a predetermined amount of time.

The watchdog timer implemented on the 8XC550 has a programmable interval and can thus be fine tuned to a particular application. If the watchdog function is not used, the timer may still be used as a versatile general purpose timer.

The watchdog function consists of a programmable 13-bit prescaler, and an 8-bit main timer. The main timer is clocked by a tap taken from one of the top 8 bits of the prescaler. The prescaler is incremented once every machine cycle, or 1/12 of the oscillator frequency. Thus, the main counter can be clocked as often as once every 64 machine cycles or as seldom as once every 8192 machine cycles.

When clocked, the main counter decrements. If the main watchdog counter reaches zero, a system reset will occur. To prevent the watchdog timer from under-flowing, the watchdog must be fed before it counts down to zero. When the watchdog is fed, the contents of the WDL register are loaded into the main watchdog counter and the prescaler is cleared.

WDCON Register

MSB					LSB		
PRE2	PRE1	PRE0	X	X	WDRUN	WDTOF	WDMOD

Symbol	Position	Function
WDCON.7	PRE2	Prescaler select (read/write).
WDCON.6	PRE1	These bits select the prescaler divide ratio according to the following table:
WDCON.5	PRE0	

PRE2	PRE1	PRE0	DIVISOR (FROM f_{osc})
0	0	0	12×64
0	0	1	$12 \times 64 \times 2$
0	1	0	$12 \times 64 \times 4$
0	1	1	$12 \times 64 \times 8$
1	0	0	$12 \times 64 \times 16$
1	0	1	$12 \times 64 \times 32$
1	1	0	$12 \times 64 \times 64$
1	1	1	$12 \times 64 \times 128$

WDCON.4	–	Not used
WDCON.3	–	Not used
WDCON.2	WDRUN	Run control (read/write). This bit turns the timer on (WDRUN = 1) or off (WDRUN = 0) if the timer mode has been selected.
WDCON.1	WDTOF	Timeout flag (read/write). This bit is set when the watchdog timer underflows. It is cleared by an external reset and can be cleared by software.
WDCON.0	WDMOD	Mode selection (read/write). When WDMOD = 1, the watchdog is selected; when WDMOD = 0, the timer is selected. Selecting the watchdog mode automatically disables power-down mode. WDMOD is cleared by external reset. Once the watchdog mode is selected, this bit can only be cleared by writing a 0 to this bit and then performing a feed operation.

80C51 8-bit microcontroller family

4K/128 OTP/ROM/ROMless, 8 channel 8 bit A/D, watchdog timer

80C550/83C550/87C550

A very specific sequence of events must take place to feed the watchdog timer; it cannot be fed accidentally by a runaway program. The following routines demonstrate setting up and feeding the watchdog timer. These routines apply to all versions of the 8XC550 except the ROM part when running from internal program memory.

This routine sets up and starts the watchdog timer. This is not necessary for internal ROM operation, because setup of the watchdog timer on masked ROM parts is accomplished directly via ROM mask options.

```
SetWD: MOV  WDL,#0FFh  ;Set watchdog reload value.
      MOV  WDCON,#0E5;Set up timer prescaler, mode, and
      ;run bits.
      ACALL FeedWD    ;Start watchdog with a feed
      ;operation.
      RET
```

This routine executes a watchdog timer feed operation, causing the timer to reload from WDL. Interrupts must be disabled during this operation due to the fact that the two feed registers must be loaded on consecutive instruction cycles, or a system reset will occur immediately.

```
FeedWD:CLR  EA          ;This sequence must not be
      ;interrupted.
      MOV  WFEED1,#0A5h;First instruction of feed sequence.
      MOV  WFEED2,#05Ah;Second instruction of feed
      ;sequence.
      SETB EA          ;Turn interrupts back on.
      RET
```

An interrupt is available to allow the watchdog timer to be used as a general purpose timer in applications where the watchdog function is not needed. The timer operates in the same manner when used as a general purpose timer except that the timer interrupt is generated on timer underflow instead of a chip reset. Refer to the 87C550 data sheet for additional information on watchdog timer operation.

Programming the Watchdog Timer

Both the EPROM and ROM devices have a set of SFRs for holding the watchdog autoloading values and the control bits. The watchdog time-out flag is present in the watchdog control register and operates the same in all versions. In the EPROM device, the watchdog parameters (autoloading value and control) are always taken from the SFRs. In the ROM device, the watchdog parameters can be mask programmed or taken from the SFRs. The selection to take the watchdog parameters from the SFRs or from the mask programmed values is controlled by EA (external access). When EA is high (internal ROM access), the watchdog parameters are taken from the mask programmed values. If the watchdog is masked programmed to the timer mode, then the autoloading values and the pre-scaler taps are taken from the SFRs. When EA is low (external access), the watchdog parameters are taken from the SFRs. The user should be able to leave code in his program which initializes the watchdog SFRs even though he has migrated to the mask ROM part. This allows no code changes from EPROM prototyping to ROM coded production parts.

Watchdog Detailed Operation

EPROM Device (and ROMless Operation: EA = 0)

In the ROMless operation (ROM part, EA = 0) and in the EPROM device, the watchdog operates in the following manner.

Whether the watchdog is in the watchdog or timer mode, when external RESET is applied, the following takes place:

- Watchdog mode bit set to timer mode.
- Watchdog run control bit set to OFF.
- Autoloading register set to FF (max count).
- Watchdog time-out flag cleared.
- Prescaler is cleared.
- Prescaler tap set to the highest divide.
- Autoloading takes place.

The watchdog can be fed even though it is in the timer mode.

Note that the operational concept is for the watchdog mode of operation, when coming out of a hardware reset, the software should load the autoloading registers, set the mode to watchdog, and then feed the watchdog (cause an autoloading). The watchdog will now be starting at a known point.

If the watchdog is in the watchdog mode and running and happens to underflow at the time the external RESET is applied, the watchdog time-out flag will be cleared.

When the watchdog is in the watchdog mode and the watchdog underflows, the following action takes place:

- Autoloading takes place.
- Watchdog time-out flag is set
- Timer mode interrupt flag unchanged.
- Mode bit unchanged.
- Watchdog run bit unchanged.
- Autoloading register unchanged.
- Prescaler tap unchanged.
- All other device action same as external reset.

Note that if the watchdog underflows, the program counter will start from 00H as in the case of an external reset. The watchdog time-out flag can be examined to determine if the watchdog has caused the reset condition. The watchdog time-out flag bit can be cleared by software.

When the watchdog is in the timer mode and the timer software underflows, the following action takes place:

- Autoloading takes place.
- Watchdog time-out flag is set
- Mode bit unchanged.
- Watchdog run bit unchanged.
- Autoloading register unchanged.
- Prescaler tap unchanged.

The timer mode interrupt flag is cleared when the interrupt routine is invoked. This bit can also be cleared directly by software without a software feed operation.

Mask ROM Device (EA = 1)

In the mask ROM device, the watchdog mode bit (WDMOD) is mask programmed and the bit in the watchdog command register is read only and reflects the mask programmed selection. If the mask programmed mode bit selects the timer mode, then the watchdog run bit (WDRUN) operates as described under EPROM Device. If the mask programmed bit selects the watchdog mode, then the watchdog run bit has no effect on the timer operation.

80C51 8-bit microcontroller family

4K/128 OTP/ROM/ROMless, 8 channel 8 bit A/D, watchdog timer

80C550/83C550/87C550

Watchdog Function

The watchdog consists of a programmable prescaler and the main timer. The prescaler derives its clock from the on-chip oscillator. The prescaler consists of a divide by 12 followed by a 13 stage counter with taps from stage 6 through stage 13. The tap selection is programmable. The watchdog main counter is a down counter clocked (decremented) each time the programmable prescaler underflows. The watchdog generates an underflow signal (and is autoloading) when the watchdog is at count 0 and the clock to decrement the watchdog occurs. The watchdog is 8 bits long and the autoloading value can range from 0 to FFH. (The autoloading value of 0 is permissible since the prescaler is cleared upon autoloading).

This leads to the following user design equations. Definitions: t_{OSC} is the oscillator period, N is the selected prescaler tap value, W is the main counter autoloading value, t_{MIN} is the minimum watchdog time-out value (when the autoloading value is 0), t_{MAX} is the maximum time-out value (when the autoloading value is FFH), t_D is the design time-out value.

$$t_{MIN} = t_{OSC} \times 12 \times 64$$

$$t_{MAX} = t_{MIN} \times 128 \times 256$$

$$t_D = t_{MIN} \times 2^{PRESCALER} \times W$$

(where prescaler = 0, 1, 2, 3, 4, 5, 6, or 7)

Note that the design procedure is anticipated to be as follows. A t_{MAX} will be chosen either from equipment or operation considerations and will most likely be the next convenient value higher than t_D . (If the watchdog were inadvertently to start from FFH, an overflow would be guaranteed, barring other anomalies, to occur within t_{MAX}). Then the value for the prescaler would be chosen from:

$$\text{prescaler} = \log_2 (t_{MAX} / (t_{OSC} \times 12 \times 256)) - 6$$

This then also fixes t_{MIN} . An autoloading value would then be chosen from:

$$W = t_D / t_{MIN} - 1$$

The software must be written so that a feed operation takes place every t_D seconds from the last feed operation. Some tradeoffs may need to be made. It is not advisable to include feed operations in minor loops or in subroutines unless the feed operation is a specific subroutine.

Interrupts

The 8XC550 interrupt structure is a seven-source, two-priority level interrupt system similar to that of the standard 80C51 microcontroller. The interrupt sources are listed below in the order of their internal polling sequence. This is the order in which simultaneous interrupts of the same priority level would be serviced.

Interrupt Priorities

PRIORITY	SOURCE	VECTOR ADDRESS	FUNCTION
Highest	INT0	0003H	External interrupt 0
	TF0	000BH	Counter/timer 0 overflow
	INT1	0013H	External interrupt 1
	TF1	001BH	Counter/timer 1 overflow
	TI & RI	0023H	Serial port transmit/receive
	ADCI	002BH	A/D converter conversion complete
Lowest	WDTOF	0033H	Watchdog timer overflow (only when not in watchdog mode)

Interrupt Control Registers

The standard 80C51 interrupt enable and priority registers have been modified slightly to take into account the additional interrupt sources of the 8XC550.

Interrupt Enable Register

MSB						LSB	
EA	EWD	EAD	ES	ET1	EX1	ET0	EX0

Symbol	Position	Function
EA	IE.7	Global interrupt enable
EWD	IE.6	Watchdog timer overflow
EAD	IE.5	A/D conversion complete
ES	IE.4	Serial port transmit or receive
ET1	IE.3	Timer 1 overflow
EX1	IE.2	External interrupt 1
ET0	IE.1	Timer 0 overflow
EX0	IE.0	External interrupt 0

Interrupt Priority Register

MSB						LSB	
-	PWD	PAD	PS	PT1	PX1	PT0	PX0

Symbol	Position	Function
PWD	IP.6	Watchdog timer
PAD	IP.5	A/D conversion
PS	IP.4	Serial port interrupt
PT1	IP.3	Timer 1 interrupt
PX1	IP.2	External interrupt 1
PT0	IP.1	Timer 0 interrupt
PX0	IP.0	External interrupt 0

Power-Down and Idle Modes

The 8XC550 includes the standard 80C51 power-down and idle modes of reduced power consumption. In addition, the 8XC550 includes an option to separately turn off the serial port for extra power savings when it is not needed. Also, the individual functional blocks such as the counter/timers are automatically disabled when they are not running. This actually turns off the clocks to the block in question, resulting in additional power savings. Note that when the watchdog timer is operating, the processor is inhibited from entering the power-down mode. This is due to the fact that the oscillator is stopped in the power-down mode, which would effectively turn off the watchdog timer. In keeping with the purpose of the watchdog timer, the processor is prevented from accidentally entering power-down due to some erroneous operation.

Power Control Register

MSB					LSB		
SMOD	SIDL	-	-	GF1	GF0	PD	IDL

Symbol	Position	Function
SMOD	PCON.7	Double baud rate bit. When set to a 1 and Timer 1 is used to generate baud rate, and the serial port is used in modes 1, 2, or 3.
SIDL	PCON.6	Separately idles the serial port for additional power savings.
-	PCON.5	Reserved
-	PCON.4	Reserved
GF1	PCON.3	General-purpose flag bit.
GF0	PCON.2	General-purpose flag bit.
PD	PCON.1	Power-down bit. Starting this bit activates power-down operation.
IDL	PCON.0	Idle mode bit. Setting this bit activates idle mode operation.

If 1s are written to PD and IDL at the same time, PD takes precedence.

80C51 8-bit microcontroller family

4K/128 OTP/ROM/ROMless, 8 channel 8 bit A/D, watchdog timer

80C550/83C550/87C550

OSCILLATOR CHARACTERISTICS

XTAL1 and XTAL2 are the input and output, respectively, of an inverting amplifier. The pins can be configured for use as an on-chip oscillator, as shown in the Block Diagram, page 3).

To drive the device from an external clock source, XTAL1 should be driven while XTAL2 is left unconnected. There are no requirements on the duty cycle of the external clock signal, because the input to the internal clock circuitry is through a divide-by-two flip-flop. However, minimum and maximum high and low times specified in the data sheet must be observed.

IDLE MODE

In idle mode, the CPU puts itself to sleep while all of the on-chip peripherals except the A/D stay active. the instruction to invoke the idle mode is the last instruction executed in the normal operating mode before the idle mode is activated. An A/D conversion in progress will be aborted when idle mode is entered. The CPU contents, the on-chip RAM, and all of the special function registers

remain intact during this mode. The idle mode can be terminated either by any enabled interrupt (at which time the process is picked up at the interrupt service routine and continued), or by a hardware reset which starts the processor in the same manner as a power-on reset.

Programmable Idle Modes

The programmable idle modes have been dispersed throughout the functional blocks. Each block has its own ability to be disabled. For example, if timer 0 is not commanded to be running (TR = 0), then the clock to the timer is disabled resulting in an idle mode power saving. An additional idle control bit has been added to the serial communications port.

A/D Operation in Idle Mode

When in the idle mode, the A/D converter will be disabled. However, the current through the V_{REF} pins will be present and will not be reduced internally in either the idle or the power-down modes. It is the responsibility of the user to disconnect V_{REF} to reduce power supply current.

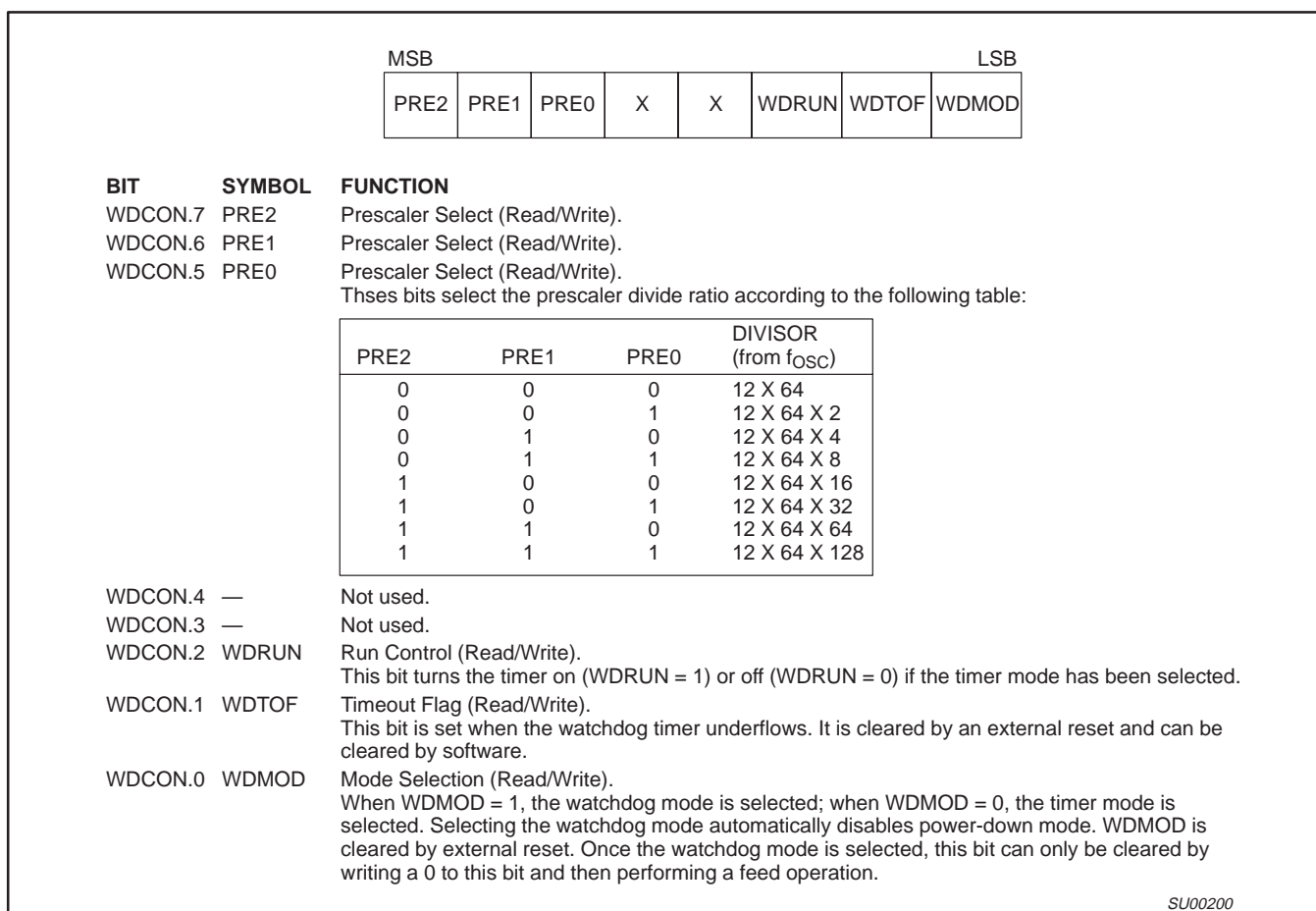

Figure 4. Watchdog Control Register (WDCON)

80C51 8-bit microcontroller family

4K/128 OTP/ROM/ROMless, 8 channel 8 bit A/D, watchdog timer

80C550/83C550/87C550

DESIGN CONSIDERATIONS

At power-on, the voltage on V_{CC} and RST must come up at the same time for a proper start-up.

When the idle mode is terminated by a hardware reset, the device normally resumes program execution, from where it left off, up to two machine cycles before the internal reset algorithm takes control. On-chip hardware inhibits access to internal RAM in this event, but access to the port pins is not inhibited. To eliminate the possibility of an unexpected write when idle is terminated by reset, the instruction following the one that invokes idle should not be one that writes to a port pin or to external memory. Table 2 shows the state of I/O ports during low current operating modes.

Encryption Table

The encryption table is a feature of the 83C550 and 87C550 that protects the code from being easily read by anyone other than the programmer. The encryption table is 32 bytes of code that are exclusive NORed with the program code data as it is read out. The first byte is XNORed with the first location read, the second with the second read, etc.

After the encryption table has been programmed, the user has to know its contents in order to correctly decode the program code data. The encryption table itself cannot be read out.

For the EPROM (87C550) part, the encryption table is programmed in the same manner as the program memory, but using the "Pgm Encryption Table" levels specified in Table 4. After the encryption table is programmed, verification cycles will produce only encrypted information.

For the ROM part (83C550) the encryption table information is submitted with the ROM code as shown in Table 3.

Security Bits

There are two security bits on the 83C550 and 87C550 that, when set, prevent the program data memory from being read out or programmed further.

After the first security bit is programmed, the external MOV_C instruction is disabled, and for the 87C550, further programming of the code memory or the encryption table is disabled. The other security bit can of course still be programmed. With only security bit one programmed, the memory can still be read out for program verification. After the second security bit is programmed, it is no longer possible to read out (verify) the program memory.

To program the security bits for the 87C550, repeat the programming sequence using the "Pgm Security Bit" levels specified in Table 4. For the masked ROM 83C550 the security bit information is submitted with the ROM code as shown in Table 3.

ROM Code Submission

When submitting a ROM code for the 83C550, the following must be specified:

1. The 4k byte user ROM program.
2. The 32 byte ROM encryption key.
3. The ROM security bits.
4. The watchdog timer parameters.

This information can be submitted in an EPROM (2764) or hex file with the format specified in Table 3.

Table 2. External Pin Status During Idle and Power-Down Modes

MODE	PROGRAM MEMORY	ALE	PSEN	PORT 0	PORT 1	PORT 2	PORT 3
Idle	Internal	1	1	Data	Data	Data	Data
Idle	External	1	1	Float	Data	Address	Data
Power-down	Internal	0	0	Data	Data	Data	Data
Power-down	External	0	0	Float	Data	Data	Data

Table 3. ROM Code Submittal Requirements

ADDRESS	CONTENT	BIT(s)	COMMENT
0000H to 0FFFH	Data	7:0	User ROM data
1000H to 101FH	Key	7:0	ROM encryption key; FFH = no encryption
1020H	Security bit	0	ROM security bit 1
1020H	Security bit	1	ROM security bit 2 0 = enable security feature 1 = disable security feature
1030H	WDCON ¹	7:5	PRE2:0
1030H	WDCON ¹	4	Not used
1030H	WDCON ¹	3	Not used
1030H	WDCON ¹	2	WDRUN = 0, not ROM coded
1030H	WDCON ¹	1	WDTOF = 0, not ROM coded
1030H	WDCON ¹	0	WDMOD
1031H	Not used		
1032H	WD	7:0	Watchdog autoloading value (see specification)

NOTE:

1. See Watchdog Timer Specification for definition of WDL and WDCON bits.

80C51 8-bit microcontroller family

4K/128 OTP/ROM/ROMless, 8 channel 8 bit A/D, watchdog timer

80C550/83C550/87C550

Electrical Deviations from Commercial Specifications for Extended Temperature Range

DC and AC parameters not included here are the same as in the commercial temperature range table.

DC ELECTRICAL CHARACTERISTICS

 $T_{amb} = -40^{\circ}\text{C}$ to $+85^{\circ}\text{C}$, $V_{CC} = 5\text{V} \pm 10\%$ (87C550), $V_{CC} = 5\text{V} \pm 20\%$ (80/83C550), $V_{SS} = 0\text{V}$

SYMBOL	PARAMETER	TEST CONDITIONS	LIMITS		UNIT
			MIN	MAX	
V_{IL}	Input low voltage, except \overline{EA}		-0.5	$0.2V_{CC}-0.15$	V
V_{IL1}	Input low voltage to \overline{EA}		0	$0.2V_{CC}-0.35$	V
V_{IH}	Input high voltage, except XTAL1, RST		$0.2V_{CC}+1$	$V_{CC}+0.5$	V
V_{IH1}	Input high voltage to XTAL1, RST		$0.7V_{CC}+0.1$	$V_{CC}+0.5$	V
I_{IL}	Logical 0 input current, ports 2, 3	$V_{IN} = 0.45\text{V}$		-75	μA
I_{TL}	Logical 1-to-0 transition current, ports 2, 3	$V_{IN} = 2.0\text{V}$		-750	μA
I_{CC}	Power supply current: Active mode Idle mode Power down mode	$V_{CC} = 4.5-5.5\text{V}$, Frequency range = 3.5 to 16MHz		35 6 50	mA mA μA

ADC DC ELECTRICAL CHARACTERISTICS

 $AV_{CC} = 5\text{V} \pm 10\%$, $AV_{SS} = 0\text{V}$, $T_{amb} = -40^{\circ}\text{C}$ to 85°C , unless otherwise specified

SYMBOL	PARAMETER	TEST CONDITIONS	LIMITS		UNIT
			MIN	MAX	
AV_{CC}	Analog supply	$AV_{CC} = V_{CC} \pm 0.2$	4.5	5.5	V
V_{REF}	Analog reference; AV_{REF+} AV_{REF-}		$AV_{SS} - 0.2$	$AV_{CC} + 0.2$	V
AI_{CC}	Analog operating supply current	See note 1		3.0	mA
AV_{IN}	Analog input voltage		$AV_{SS} - 0.2$	$AV_{CC} + 0.2$	V
A_{IC} , C_{IA}	Analog input capacitance			15	pF
t_{ADS}	Sampling time			$8t_{CY}$	
t_{ADC}	Conversion time			$40t_{CY}$	
A_e	Absolute voltage error			± 1.5	LSB
E_{RA}	Relative accuracy			± 1	LSB
O_{Se}	Offset error	See note 1		± 1	LSB
G_e	Gain error	See note 1		0.4	%
M_{CTC}	Channel-to-channel matching			± 1	LSB
C_t	Crosstalk	0 – 100kHz		-60	dB
R_{ref}	Resistance between AV_{REF+} and AV_{REF-}		1.0	10.0	$\text{K}\Omega$
AI_{ID}	Idle mode supply current	See note 4		50	μA
AI_{PD}	Power down supply current	See note 4		50	μA

NOTES:

- Conditions: $V_{REF+} = 4.99712\text{V}$, $V_{REF-} = 0\text{V}$. AI_{CC} value does not include the resistor ladder current. For the 40-pin package, where the V_{REF-} inputs are connected to AV_{CC} and AV_{SS} , the current AI_{CC} will be increased by the register ladder current and may exceed the maximum shown here.
- The resistor ladder network is not disconnected in the power-down or idle modes. Thus to conserve power, the user must remove AV_{CC} and V_{REF+} .
- If the A/D function is not required, or if the A/D function is only needed periodically, AV_{CC} can be removed without affecting the operation of the digital circuitry. Contents of ADCON and ADAT are not guaranteed to be valid. Digital inputs P1.0 to P1.7 will not function normally. No digital outputs are present on these pins.
- For this test, the Analog inputs must be at the supplies (either V_{DD} or V_{SS}).

80C51 8-bit microcontroller family

4K/128 OTP/ROM/ROMless, 8 channel 8 bit A/D, watchdog timer

80C550/83C550/87C550

ABSOLUTE MAXIMUM RATINGS^{1, 2, 3}

PARAMETER	RATING	UNIT
Operating temperature under bias	-40 to +85	°C
Storage temperature range	-65 to +150	°C
Voltage on \overline{EA}/V_{PP} pin to V_{SS} (87C550 only)	0 to +13.0	V
Voltage on any other pin to V_{SS}	-0.5 to +6.5	V
Input, output current on any two I/O pins	± 10	mA
Power dissipation (based on package heat transfer limitations, not device power consumption)	1.5	W

NOTES:

- Stresses above those listed under Absolute Maximum Ratings may cause permanent damage to the device. This is a stress rating only and functional operation of the device at these or any conditions other than those described in the AC and DC Electrical Characteristics section of this specification is not implied.
- This product includes circuitry specifically designed for the protection of its internal devices from the damaging effects of excessive static charge. Nonetheless, it is suggested that conventional precautions be taken to avoid applying greater than the rated maxima.
- Parameters are valid over operating temperature range unless otherwise specified. All voltages are with respect to V_{SS} unless otherwise noted.

DC ELECTRICAL CHARACTERISTICS

 $T_{amb} = 0^{\circ}\text{C to } +70^{\circ}\text{C or } -40^{\circ}\text{C to } +85^{\circ}\text{C}$, $V_{CC} = 5\text{V} \pm 10\%$ (87C550), $V_{CC} = 5\text{V} \pm 20\%$ (80/83C550), $V_{SS} = 0\text{V}$

SYMBOL	PARAMETER	TEST CONDITIONS	LIMITS			UNIT
			MIN	TYPICAL ¹	MAX	
V_{IL}	Input low voltage, except \overline{EA} ⁷		-0.5		$0.2V_{CC}-0.1$	V
V_{IL1}	Input low voltage to \overline{EA} ⁷		0		$0.2V_{CC}-0.3$	V
V_{IH}	Input high voltage, except XTAL1, RST ⁷		$0.2V_{CC}+0.9$		$V_{CC}+0.5$	V
V_{IH1}	Input high voltage, XTAL1, RST ⁷		$0.7V_{CC}$		$V_{CC}+0.5$	V
V_{OL}	Output low voltage, ports 2, 3	$I_{OL} = 1.6\text{mA}^2$			0.45	V
V_{OL1}	Output low voltage, port 0, ALE, \overline{PSEN}	$I_{OL} = 3.2\text{mA}^2$			0.45	V
V_{OH}	Output high voltage, ports 2, 3, ALE, \overline{PSEN} ³	$I_{OH} = -60\mu\text{A}$ $I_{OH} = -25\mu\text{A}$ $I_{OH} = -10\mu\text{A}$	2.4 $0.75V_{CC}$ $0.9V_{CC}$			V V V
V_{OH1}	Output high voltage (port 0 in external bus mode)	$I_{OH} = -800\mu\text{A}$ $I_{OH} = -300\mu\text{A}$ $I_{OH} = -80\mu\text{A}$	2.4 $0.75V_{CC}$ $0.9V_{CC}$			V V V
I_{IL}	Logical 0 input current, ports 1, 2, 3 ⁷	$V_{IN} = 0.45\text{V}$			-50	μA
I_{TL}	Logical 1-to-0 transition current, ports 1, 2, 3 ⁷	See note 4			-650	μA
I_{LI}	Input leakage current, port 0	$V_{IN} = V_{IL}$ or V_{IH}			± 10	μA
I_{CC}	Power supply current (does not include $A I_{CC}$): ⁷ Active mode @ 16MHz ⁵ Idle mode @ 16MHz Power down mode	See note 6		11.5 1.3 3	25 5 50	mA mA μA
R_{RST}	Internal reset pull-down resistor		50		300	k Ω
C_{IO}	Pin capacitance (I/O pins only)				10	pF

NOTES:

- Typical ratings are not guaranteed. The values listed are at room temperature, 5V.
- Capacitive loading on ports 0 and 2 may cause spurious noise to be superimposed on the V_{OL} s of ALE and ports 1 and 3. The noise is due to external bus capacitance discharging into the port 0 and port 2 pins when these pins make 1-to-0 transitions during bus operations. In the worst cases (capacitive loading > 100pF), the noise pulse on the ALE pin may exceed 0.8V. In such cases, it may be desirable to qualify ALE with a Schmitt Trigger, or use an address latch with a Schmitt Trigger STROBE input.
- Capacitive loading on ports 0 and 2 may cause the V_{OH} on ALE and \overline{PSEN} to momentarily fall below the $0.9V_{CC}$ specification when the address bits are stabilizing.
- Pins of ports 2 and 3 source a transition current when they are being externally driven from 1 to 0. The transition current reaches its maximum value when V_{IN} is approximately 2V.
- I_{CCMAX} at other frequencies is given by: Active mode; $I_{CCMAX} = 1.43 \times \text{FREQ} + 1.90$; Idle mode; $I_{CCMAX} = 0.14 \times \text{FREQ} + 2.31$, where FREQ is the external oscillator frequency in MHz. I_{CCMAX} is given in mA. See Figure 12.
- See Figures 13 through 16 for I_{CC} test conditions.
- These values apply only to $T_{amb} = 0^{\circ}\text{C to } +70^{\circ}\text{C}$. For $T_{amb} = -40^{\circ}\text{C to } +85^{\circ}\text{C}$. See table on previous page.

80C51 8-bit microcontroller family

4K/128 OTP/ROM/ROMless, 8 channel 8 bit A/D, watchdog timer

80C550/83C550/87C550

AC ELECTRICAL CHARACTERISTICS

 $T_{amb} = 0^{\circ}\text{C to } +70^{\circ}\text{C or } -40^{\circ}\text{C to } +85^{\circ}\text{C}$, $V_{CC} = 5\text{V} \pm 10\%$ (87C550), $V_{CC} = 5\text{V} \pm 20\%$ (80/83C550), $V_{SS} = 0\text{V}^{1, 2}$

SYMBOL	FIGURE	PARAMETER	16MHz CLOCK		VARIABLE CLOCK		UNIT
			MIN	MAX	MIN	MAX	
$1/t_{CLCL}$	5	Oscillator frequency: Speed Versions S8XC550 Exx			3.5	16	MHz
t_{LHLL}	5	ALE pulse width	85		$2t_{CLCL}-40$		ns
t_{AVLL}	5	Address valid to ALE low	7		$t_{CLCL}-55$		ns
t_{LLAX}	5	Address hold after ALE low	27		$t_{CLCL}-35$		ns
t_{LLIV}	5	ALE low to valid instruction in		150		$4t_{CLCL}-100$	ns
t_{LLPL}	5	ALE low to PSEN low	22		$t_{CLCL}-40$		ns
t_{PLPH}	5	PSEN pulse width	142		$3t_{CLCL}-45$		ns
t_{PLIV}	5	PSEN low to valid instruction in		82		$3t_{CLCL}-105$	ns
t_{PXIX}	5	Input instruction hold after PSEN	0		0		ns
t_{PXIZ}	5	Input instruction float after PSEN		37		$t_{CLCL}-25$	ns
t_{AVIV}	5	Address to valid instruction in		207		$5t_{CLCL}-105$	ns
t_{PLAZ}	5	PSEN low to address float		10		10	ns
Data Memory							
t_{RLRH}	6, 7	\overline{RD} pulse width	275		$6t_{CLCL}-100$		ns
t_{WLWH}	6, 7	\overline{WR} pulse width	275		$6t_{CLCL}-100$		ns
t_{RLDV}	6, 7	\overline{RD} low to valid data in		212		$5t_{CLCL}-165$	ns
t_{RHDX}	6, 7	Data hold after \overline{RD}	0		0		ns
t_{RHDZ}	6, 7	Data float after \overline{RD}		55		$2t_{CLCL}-70$	ns
t_{LLDV}	6, 7	ALE low to valid data in		350		$8t_{CLCL}-150$	ns
t_{AVDV}	6, 7	Address to valid data in		397		$9t_{CLCL}-165$	ns
t_{LLWL}	6, 7	ALE low to \overline{RD} or \overline{WR} low	137	247	$3t_{CLCL}-50$	$3t_{CLCL}+50$	ns
t_{AVWL}	6, 7	Address valid to \overline{WR} low or \overline{RD} low	120		$4t_{CLCL}-130$		ns
t_{QVWX}	6, 7	Data valid to \overline{WR} transition	12		$t_{CLCL}-50$		ns
t_{WHQX}	6, 7	Data hold after \overline{WR}	12		$t_{CLCL}-50$		ns
t_{RLAZ}	6, 7	\overline{RD} low to address float		0		0	ns
t_{WHLH}	6, 7	\overline{RD} or \overline{WR} high to ALE high	22	102	$t_{CLCL}-40$	$t_{CLCL}+40$	ns
External Clock							
t_{CHCX}	9	High time	20		20		ns
t_{CLCX}	9	Low time	20		20		ns
t_{CLCH}	9	Rise time		20		20	ns
t_{CHCL}	9	Fall time		20		20	ns
Shift Register							
t_{XLXL}	8	Serial port clock cycle time	750		$12t_{CLCL}$		ns
t_{QVXH}	8	Output data setup to clock rising edge	492		$10t_{CLCL}-133$		ns
t_{XHQX}	8	Output data hold after clock rising edge	8		$2t_{CLCL}-117$		ns
t_{XHDX}	8	Input data hold after clock rising edge	0		0		ns
t_{XHDV}	8	Clock rising edge to input data valid		492		$10t_{CLCL}-133$	ns

NOTES:

- Parameters are valid over operating temperature range unless otherwise specified.
- Load capacitance for port 0, ALE, and PSEN = 100pF, load capacitance for all other outputs = 80pF.

80C51 8-bit microcontroller family

4K/128 OTP/ROM/ROMless, 8 channel 8 bit A/D, watchdog timer

80C550/83C550/87C550

EXPLANATION OF THE AC SYMBOLS

Each timing symbol has five characters. The first character is always 't' (= time). The other characters, depending on their positions, indicate the name of a signal or the logical status of that signal. The designations are:

- A – Address
- C – Clock
- D – Input data
- H – Logic level high
- I – Instruction (program memory contents)
- L – Logic level low, or ALE

- P – $\overline{\text{PSEN}}$
- Q – Output data
- R – $\overline{\text{RD}}$ signal
- t – Time
- V – Valid
- W – $\overline{\text{WR}}$ signal
- X – No longer a valid logic level
- Z – Float

Examples: t_{AVLL} = Time for address valid to ALE low.
 t_{LLPL} = Time for ALE low to $\overline{\text{PSEN}}$ low.

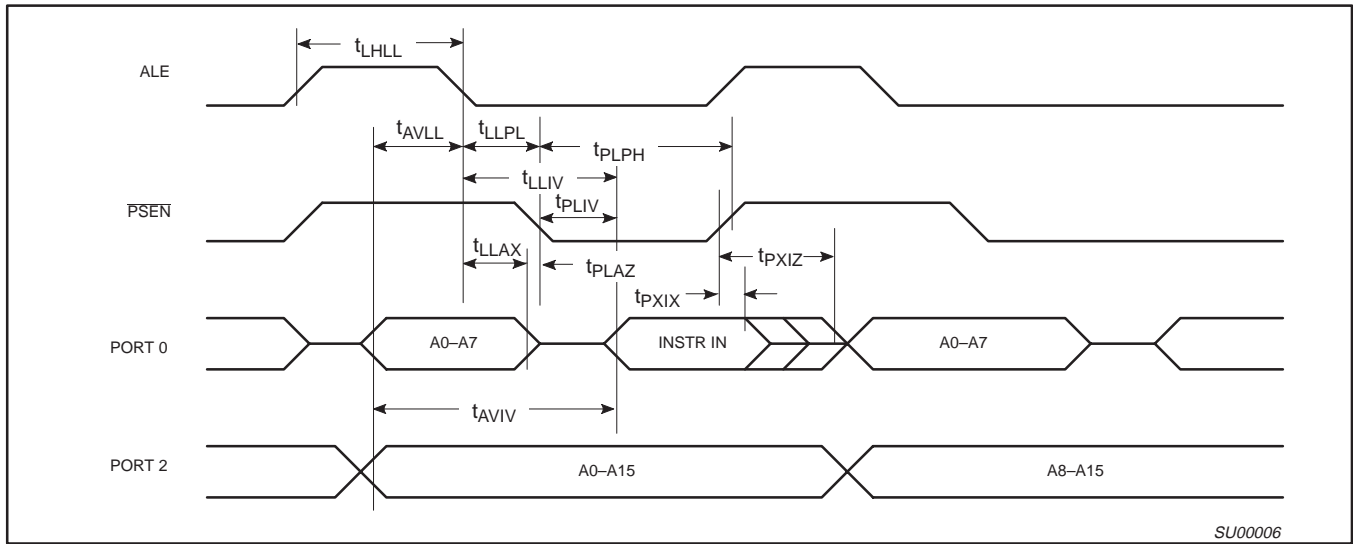

Figure 5. External Program Memory Read Cycle

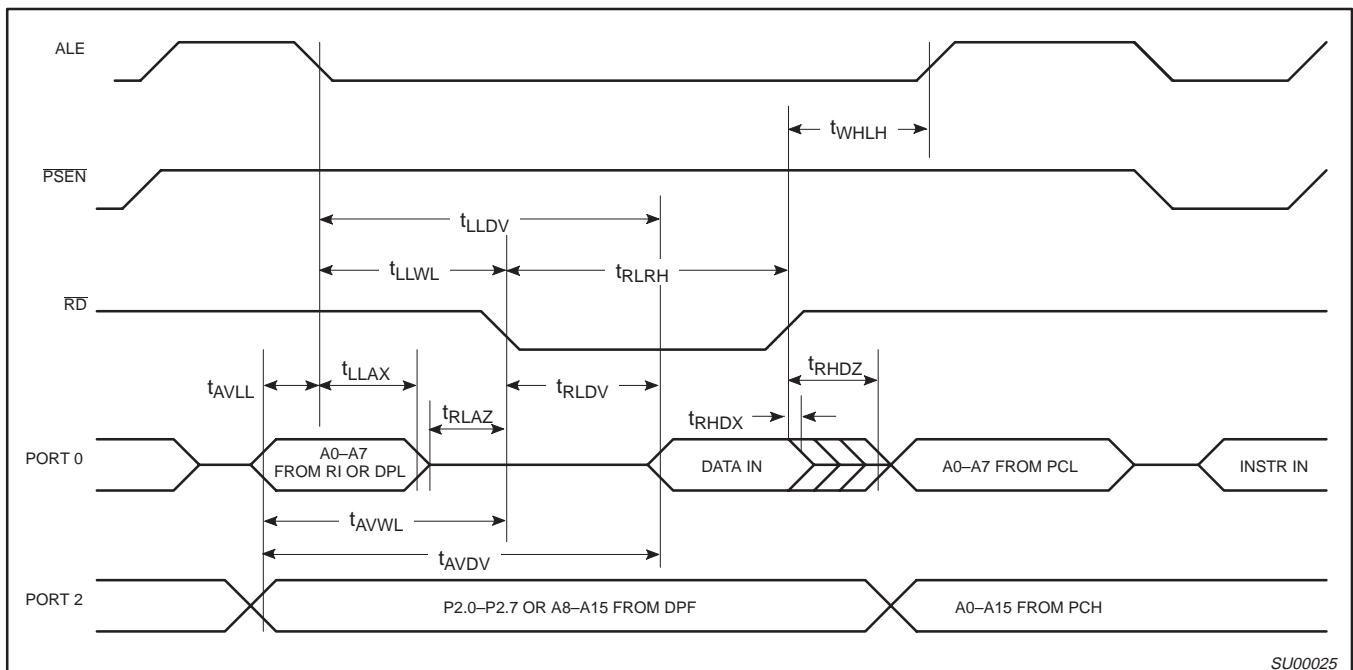

Figure 6. External Data Memory Read Cycle

80C51 8-bit microcontroller family

4K/128 OTP/ROM/ROMless, 8 channel 8 bit A/D, watchdog timer

80C550/83C550/87C550

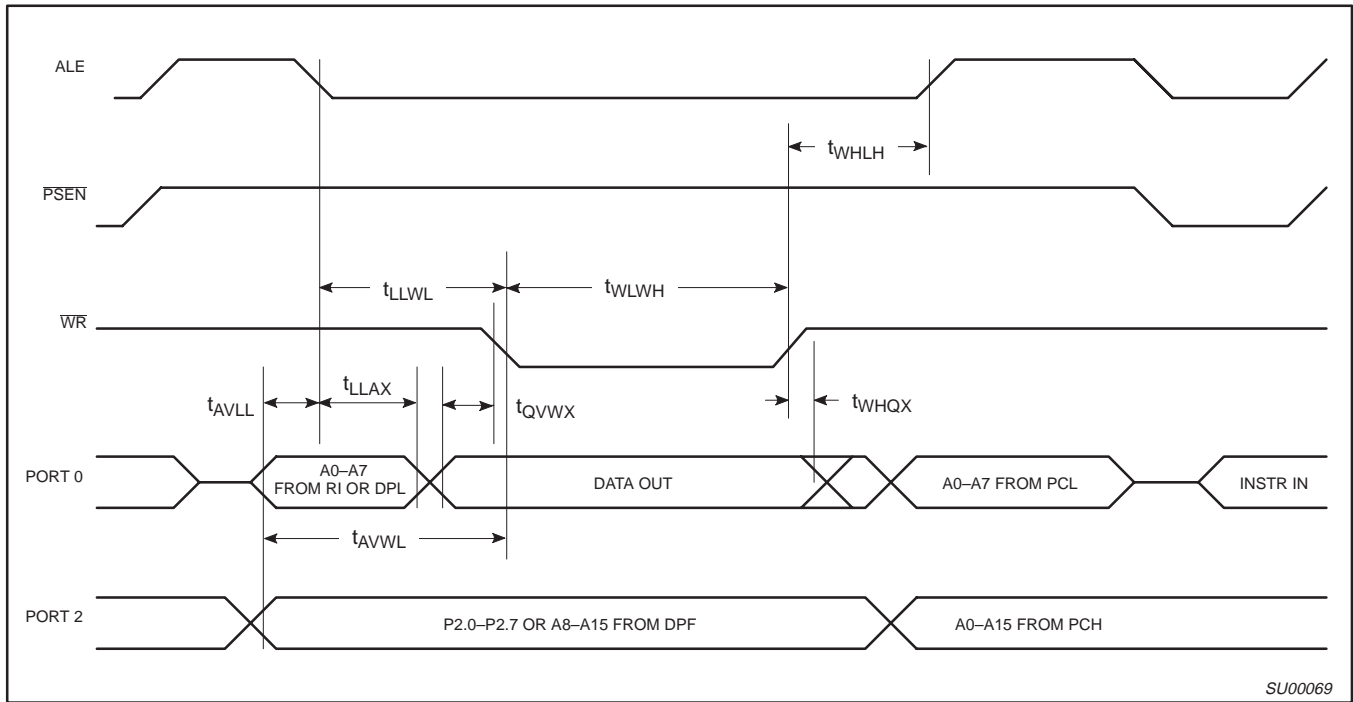

Figure 7. External Data Memory Write Cycle

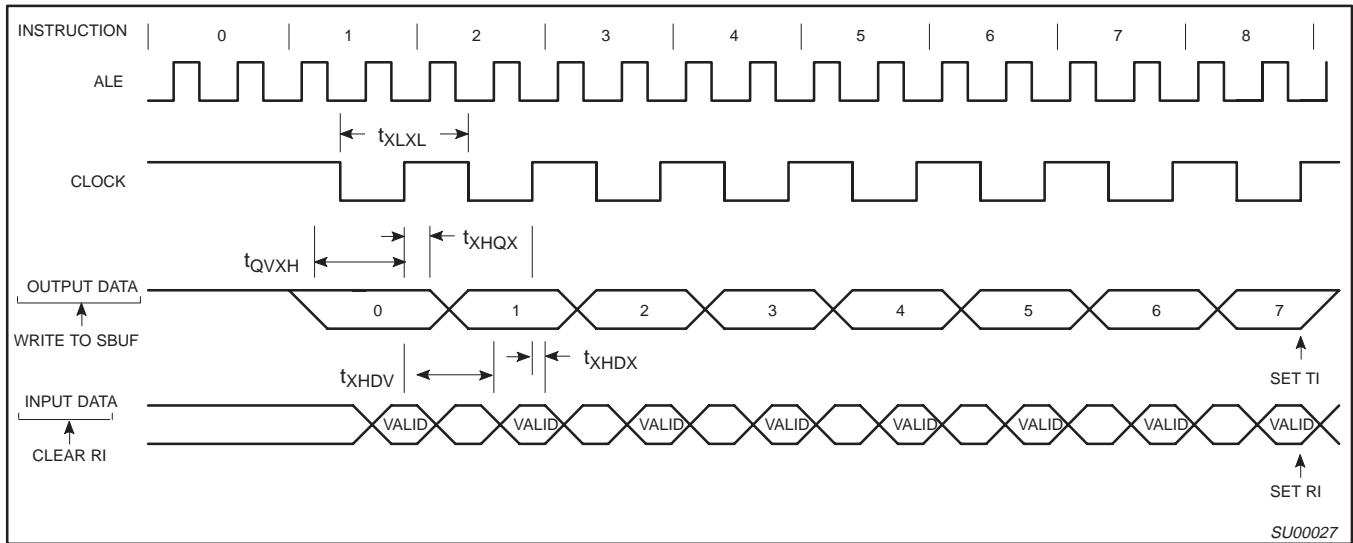

Figure 8. Shift Register Mode Timing

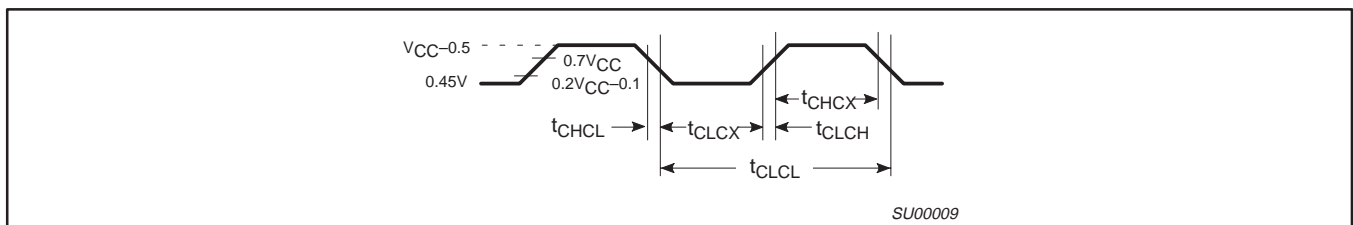

Figure 9. External Clock Drive

80C51 8-bit microcontroller family

4K/128 OTP/ROM/ROMless, 8 channel 8 bit A/D, watchdog timer

80C550/83C550/87C550

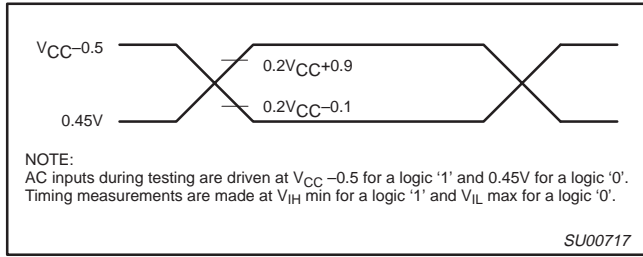

Figure 10. AC Testing Input/Output

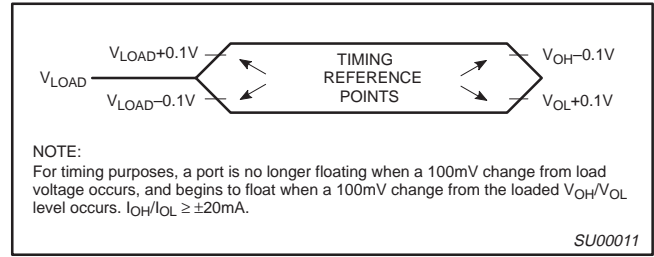

Figure 11. Float Waveform

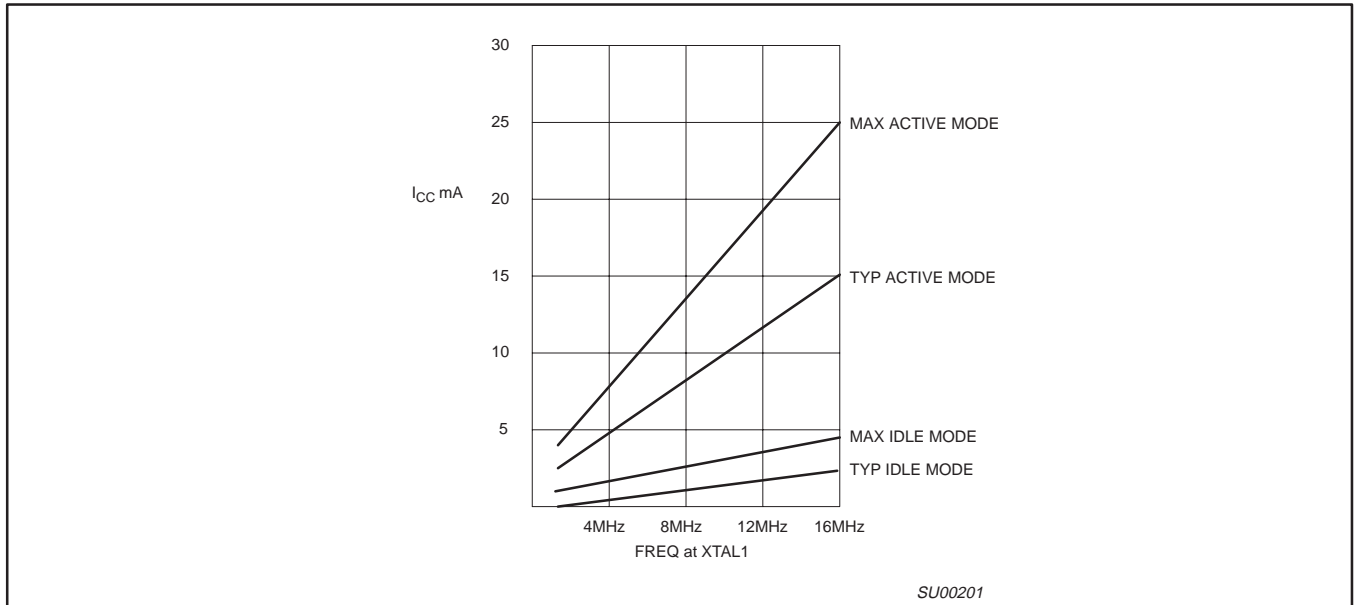

Figure 12. I_{CC} vs. FREQ (Commercial Temp. Range)
Valid only within frequency specifications of the device under test

80C51 8-bit microcontroller family

4K/128 OTP/ROM/ROMless, 8 channel 8 bit A/D, watchdog timer

80C550/83C550/87C550

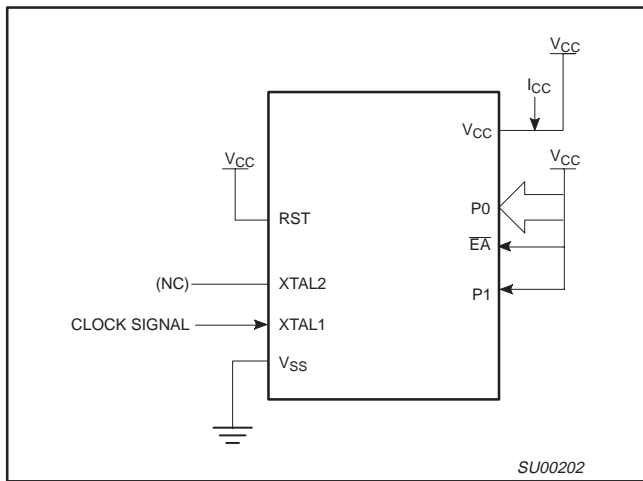

Figure 13. I_{CC} Test Condition, Active Mode
All other pins are disconnected

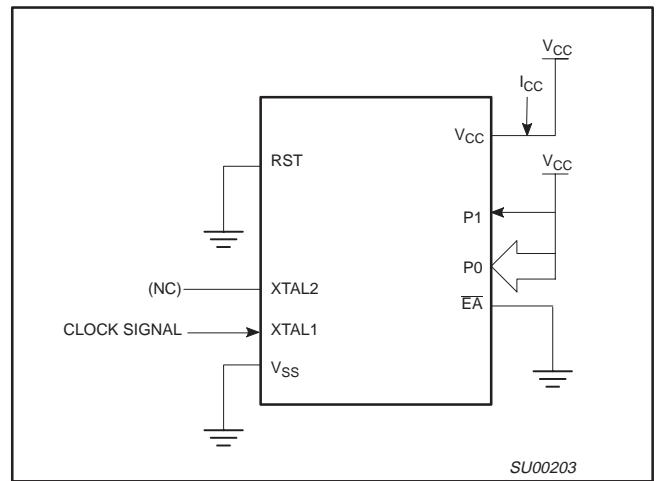

Figure 14. I_{CC} Test Condition, Idle Mode
All other pins are disconnected

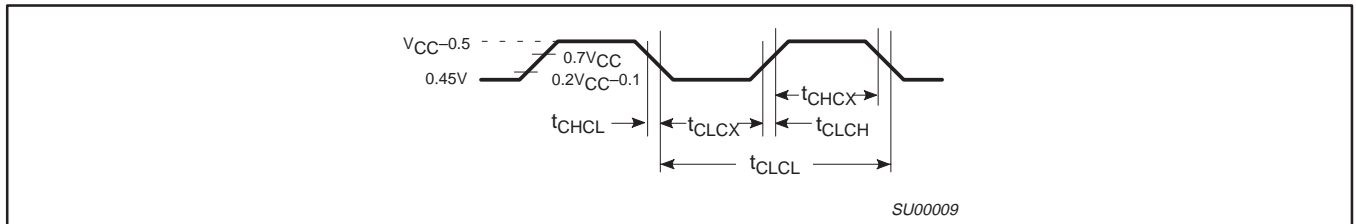

Figure 15. Clock Signal Waveform for I_{CC} Tests in Active and Idle Modes
 $t_{CLCH} = t_{CHCL} = 5\text{ns}$

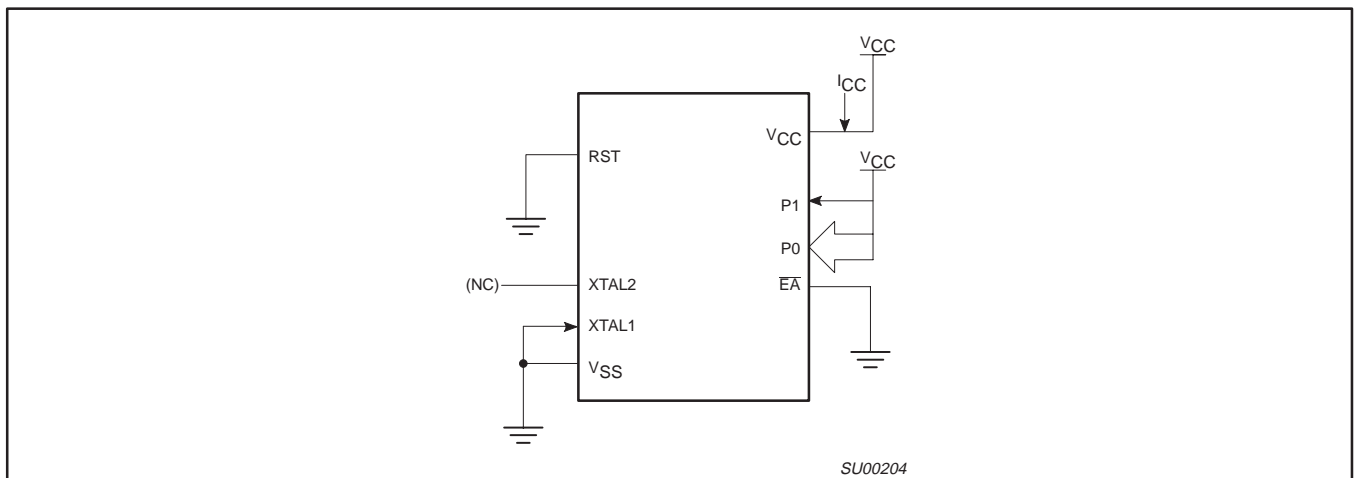

Figure 16. I_{CC} Test Condition, Power Down Mode
All other pins are disconnected.
 $V_{CC} = 2\text{V to } 5.5\text{V}$.

80C51 8-bit microcontroller family

4K/128 OTP/ROM/ROMless, 8 channel 8 bit A/D, watchdog timer

80C550/83C550/87C550

EPROM CHARACTERISTICS

The 87C550 is programmed by using a modified Quick-Pulse Programming™ algorithm. It differs from older methods in the value used for V_{PP} (programming supply voltage) and in the width and number of the ALE/PROG pulses.

The 87C550 contains two signature bytes that can be read and used by an EPROM programming system to identify the device. The signature bytes identify the device as an S87C550 manufactured by Philips.

Table 4 shows the logic levels for reading the signature byte, and for programming the program memory, the encryption table, and the lock bits. The circuit configuration and waveforms for quick-pulse programming are shown in Figures 17 and 18. Figure 19 shows the circuit configuration for normal program memory verification.

Quick-Pulse Programming

The setup for microcontroller quick-pulse programming is shown in Figure 17. Note that the 87C550 is running with a 4 to 6MHz oscillator. The reason the oscillator needs to be running is that the device is executing internal address and program data transfers.

The address of the EPROM location to be programmed is applied to ports 2 and 3, as shown in Figure 17. The code byte to be programmed into that location is applied to port 0. RST, \overline{PSEN} and pins of ports 1 and 2 specified in Table 4 are held at the 'Program Code Data' levels indicated in Table 4. The ALE/PROG is pulsed low 25 times as shown in Figure 18.

To program the encryption table, repeat the 25 pulse programming sequence for addresses 0 through 1FH, using the 'Pgm Encryption Table' levels. Do not forget that after the encryption table is programmed, verification cycles will produce only encrypted data.

To program the security bits, repeat the 25 pulse programming sequence using the 'Pgm Security Bit' levels. After one security bit is

programmed, further programming of the code memory and encryption table is disabled. However, the other security bit can still be programmed.

Note that the \overline{EA}/V_{PP} pin must not be allowed to go above the maximum specified V_{PP} level for any amount of time. Even a narrow glitch above that voltage can cause permanent damage to the device. The V_{PP} source should be well regulated and free of glitches and overshoot.

Program Verification

If security bit 2 has not been programmed, the on-chip program memory can be read out for program verification. The address of the program memory locations to be read is applied to ports 2 and 3 as shown in Figure 19. The other pins are held at the 'Verify Code Data' levels indicated in Table 4. The contents of the address location will be emitted on port 0. External pull-ups are required on port 0 for this operation.

If the encryption table has been programmed, the data presented at port 0 will be the exclusive NOR of the program byte with one of the encryption bytes. The user will have to know the encryption table contents in order to correctly decode the verification data. The encryption table itself cannot be read out.

Reading the Signature Bytes

The signature bytes are read by the same procedure as a normal verification of locations 030H and 031H, except that P1.0 and P1.1 need to be pulled to a logic low. The values are:
(030H) = 15H indicates manufactured by Philips
(031H) = 96H indicates S87C550

Program/Verify Algorithms

Any algorithm in agreement with the conditions listed in Table 4, and which satisfies the timing specifications, is suitable.

Table 4. EPROM Programming Modes

MODE	RST	\overline{PSEN}	ALE/PROG	\overline{EA}/V_{PP}	P2.7	P2.6	P1.1	P1.0
Read signature	1	0	1	1	0	0	0	0
Program code data	1	0	0*	V_{PP}	1	0	1	1
Verify code data	1	0	1	1	0	0	1	1
Pgm encryption table	1	0	0*	V_{PP}	1	0	1	0
Pgm security bit 1	1	0	0*	V_{PP}	1	1	1	1
Pgm security bit 2	1	0	0*	V_{PP}	1	1	0	0

NOTES:

- '0' = Valid low for that pin, '1' = valid high for that pin.
- $V_{PP} = 12.75V \pm 0.25V$.
- $V_{CC} = 5V \pm 10\%$ during programming and verification.

* ALE/PROG receives 25 programming pulses while V_{PP} is held at 12.75V. Each programming pulse is low for 100 μ s ($\pm 10\mu$ s) and high for a minimum of 10 μ s.

™Trademark phrase of Intel Corporation.

80C51 8-bit microcontroller family

4K/128 OTP/ROM/ROMless, 8 channel 8 bit A/D, watchdog timer

80C550/83C550/87C550

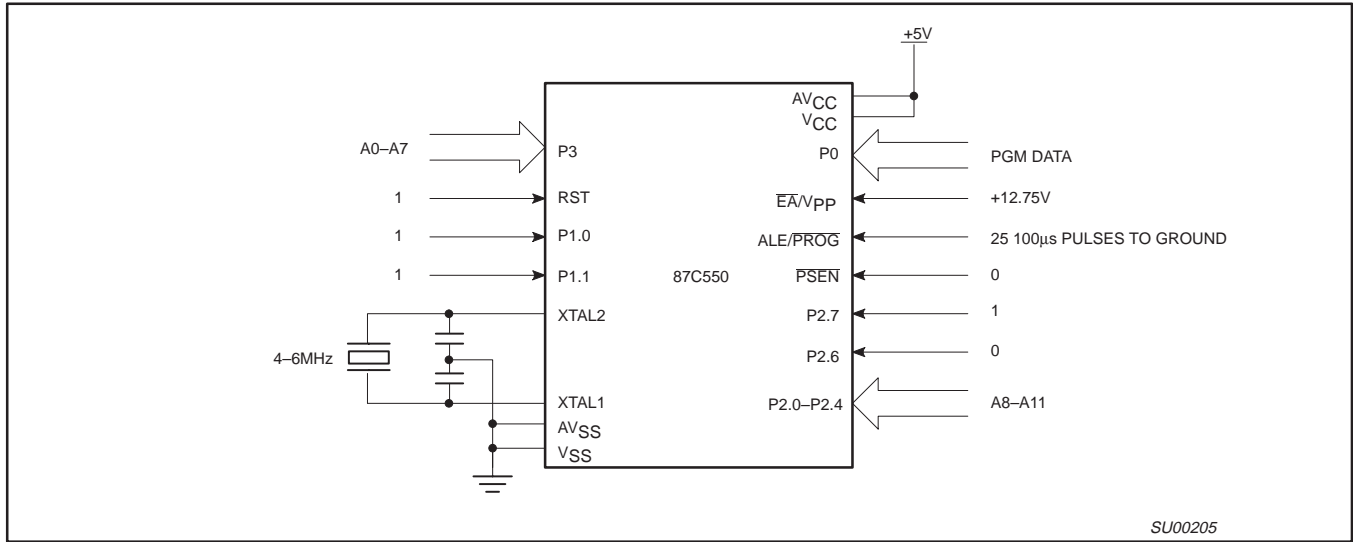

Figure 17. Programming Configuration

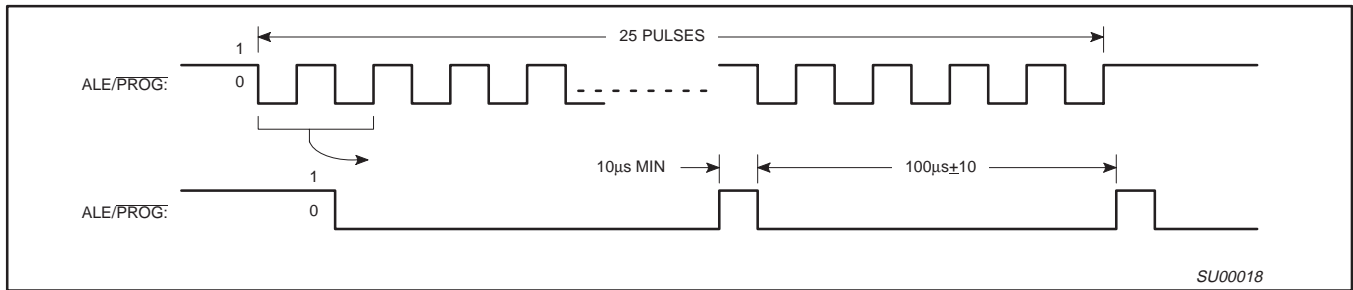

Figure 18. PROG Waveform

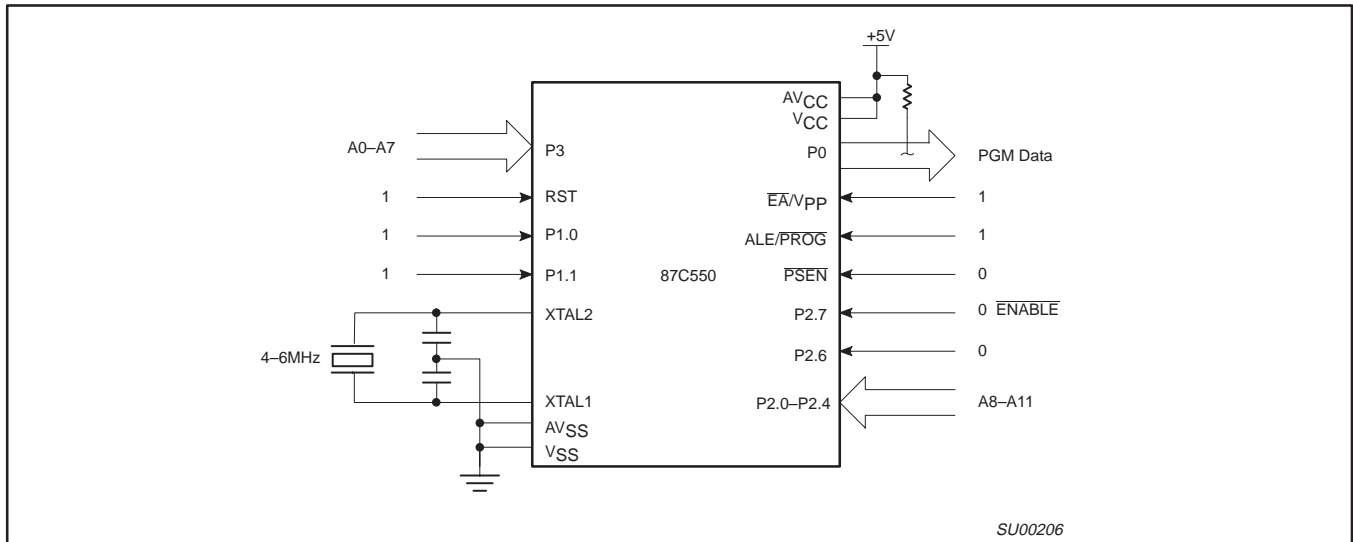

Figure 19. Program Verification

80C51 8-bit microcontroller family

4K/128 OTP/ROM/ROMless, 8 channel 8 bit A/D, watchdog timer

80C550/83C550/87C550

EPROM PROGRAMMING AND VERIFICATION CHARACTERISTICS

T_{amb} = 21°C to +27°C, V_{CC} = 5V±10%, V_{SS} = 0V (See Figure 20)

SYMBOL	PARAMETER	MIN	MAX	UNIT
V _{PP}	Programming supply voltage	12.5	13.0	V
I _{PP}	Programming supply current		50	mA
1/t _{CLCL}	Oscillator frequency	4	6	MHz
t _{AVGL}	Address setup to PROG low	48t _{CLCL}		
t _{GHAX}	Address hold after PROG	48t _{CLCL}		
t _{DVGL}	Data setup to PROG low	48t _{CLCL}		
t _{GHDx}	Data hold after PROG	48t _{CLCL}		
t _{EHS}	P2.7 ($\overline{\text{ENABLE}}$) high to V _{PP}	48t _{CLCL}		
t _{SHGL}	V _{PP} setup to PROG low	10		μs
t _{GHSL}	V _{PP} hold after PROG	10		μs
t _{GLGH}	PROG width	90	110	μs
t _{AVQV}	Address to data valid		48t _{CLCL}	
t _{ELQZ}	ENABLE low to data valid		48t _{CLCL}	
t _{EHQZ}	Data float after ENABLE	0	48t _{CLCL}	
t _{GHGL}	PROG high to PROG low	10		μs

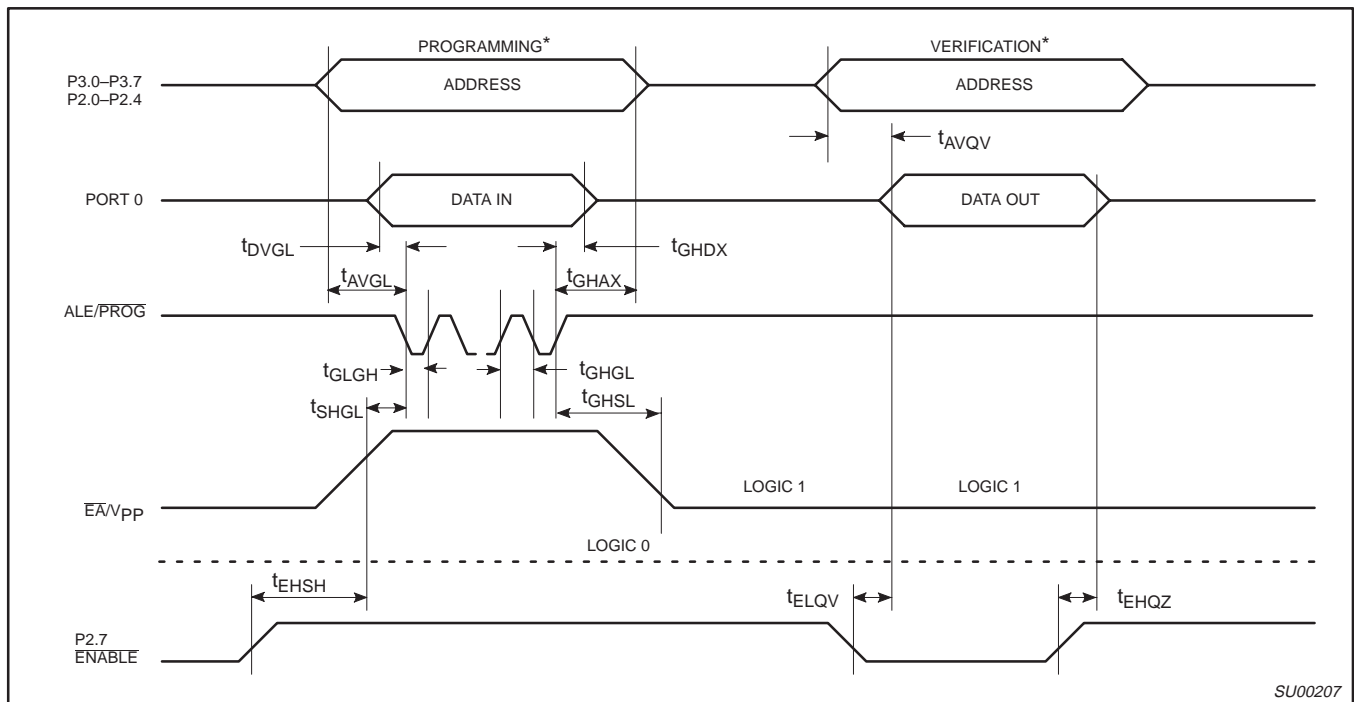

NOTE:

* FOR PROGRAMMING VERIFICATION, SEE FIGURE 17.
 FOR VERIFICATION CONDITIONS, SEE FIGURE 19.

Figure 20. EPROM Programming and Verification

80C51 8-bit microcontroller family

4K/128 OTP/ROM/ROMless, 8 channel 8 bit A/D, watchdog timer

80C550/83C550/87C550

DIP40: plastic dual in-line package; 40 leads (600 mil)

SOT129-1

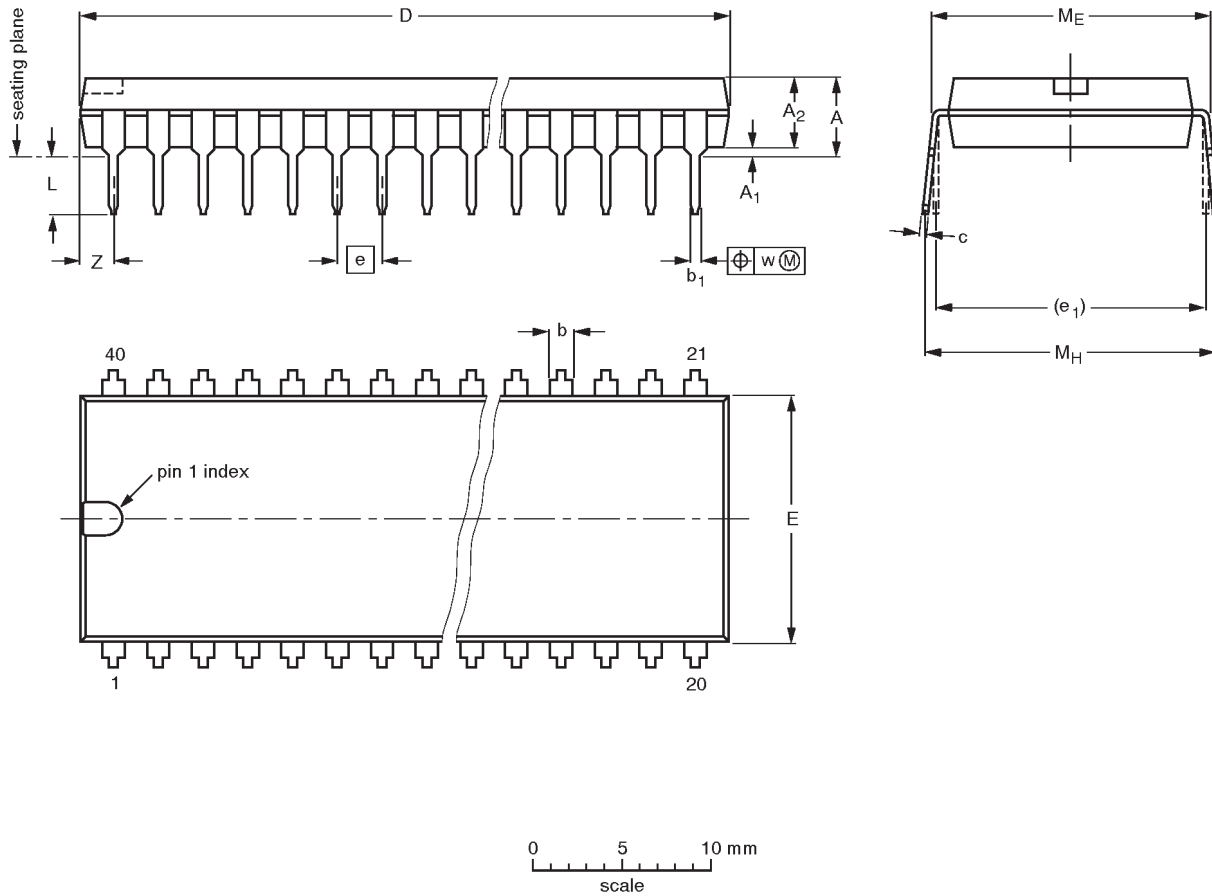

DIMENSIONS (inch dimensions are derived from the original mm dimensions)

UNIT	A max.	A ₁ min.	A ₂ max.	b	b ₁	c	D ⁽¹⁾	E ⁽¹⁾	e	e ₁	L	M _E	M _H	w	Z ⁽¹⁾ max.
mm	4.7	0.51	4.0	1.70 1.14	0.53 0.38	0.36 0.23	52.50 51.50	14.1 13.7	2.54	15.24	3.60 3.05	15.80 15.24	17.42 15.90	0.254	2.25
inches	0.19	0.020	0.16	0.067 0.045	0.021 0.015	0.014 0.009	2.067 2.028	0.56 0.54	0.10	0.60	0.14 0.12	0.62 0.60	0.69 0.63	0.01	0.089

Note

1. Plastic or metal protrusions of 0.25 mm maximum per side are not included.

OUTLINE VERSION	REFERENCES				EUROPEAN PROJECTION	ISSUE DATE
	IEC	JEDEC	EIAJ			
SOT129-1	051G08	MO-015AJ				92-11-17 95-01-14

80C51 8-bit microcontroller family

80C550/83C550/87C550

4K/128 OTP/ROM/ROMless, 8 channel 8 bit A/D, watchdog timer

PLCC44: plastic leaded chip carrier; 44 leads

SOT187-2

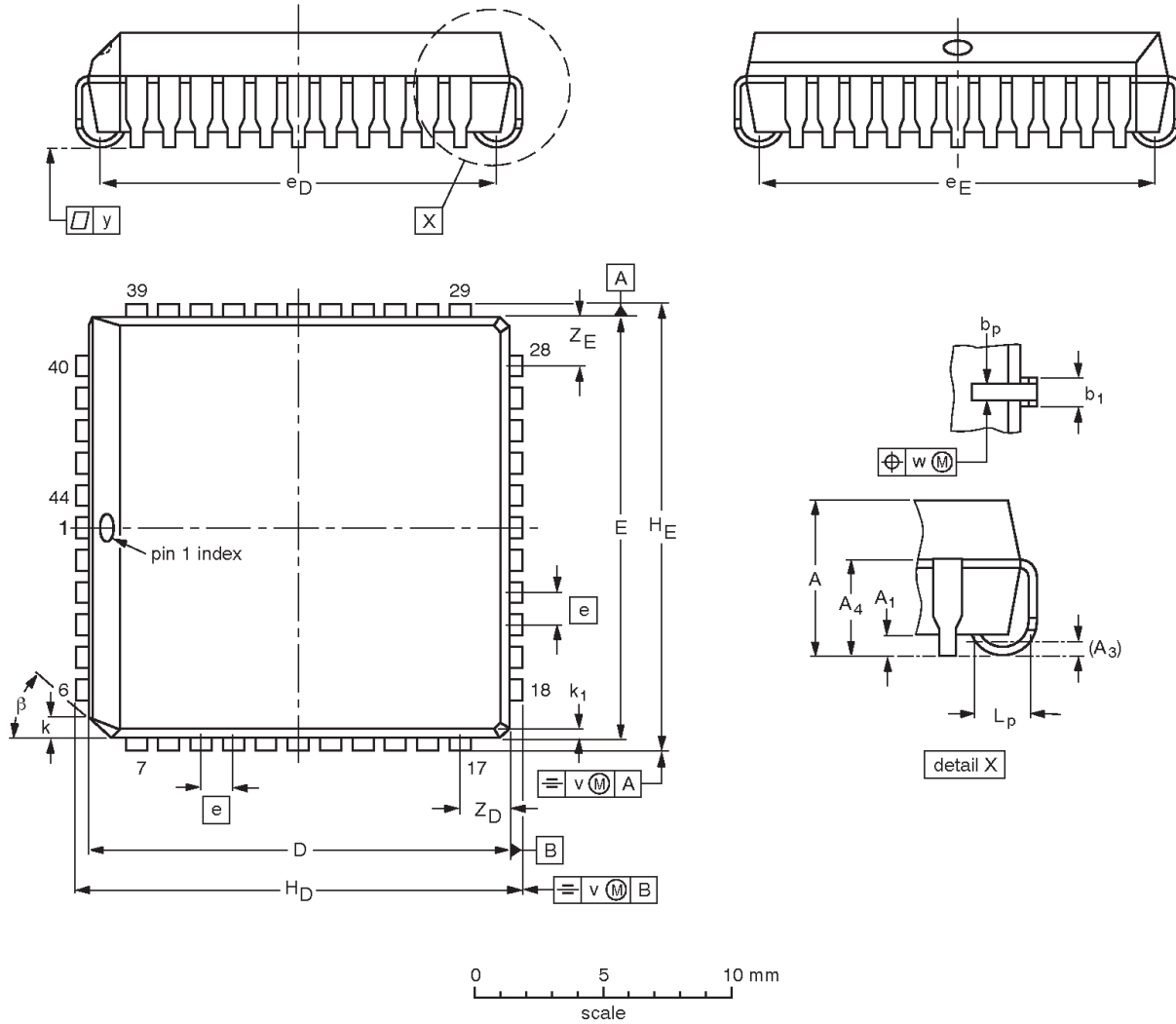

DIMENSIONS (millimetre dimensions are derived from the original inch dimensions)

UNIT	A	A ₁ min.	A ₃	A ₄ max.	b _p	b ₁	D ⁽¹⁾	E ⁽¹⁾	e	e _D	e _E	H _D	H _E	k	k ₁ max.	L _p	v	w	y	Z _D ⁽¹⁾ max.	Z _E ⁽¹⁾ max.	β
mm	4.57 4.19	0.51	0.25	3.05	0.53 0.33	0.81 0.66	16.66 16.51	16.66 16.51	1.27	16.00 14.99	16.00 14.99	17.65 17.40	17.65 17.40	1.22 1.07	0.51	1.44 1.02	0.18	0.18	0.10	2.16	2.16	45°
inches	0.180 0.165	0.020	0.01	0.12	0.021 0.013	0.032 0.026	0.656 0.650	0.656 0.650	0.05	0.630 0.590	0.630 0.590	0.695 0.685	0.695 0.685	0.048 0.042	0.020	0.057 0.040	0.007	0.007	0.004	0.085	0.085	

Note

1. Plastic or metal protrusions of 0.01 inches maximum per side are not included.

OUTLINE VERSION	REFERENCES				EUROPEAN PROJECTION	ISSUE DATE
	IEC	JEDEC	EIAJ			
SOT187-2	112E10	MO-047AC				95-02-25 97-12-16

80C51 8-bit microcontroller family

4K/128 OTP/ROM/ROMless, 8 channel 8 bit A/D, watchdog timer

80C550/83C550/87C550

NOTES

80C51 8-bit microcontroller family

4K/128 OTP/ROM/ROMless, 8 channel 8 bit A/D, watchdog timer

80C550/83C550/87C550**Data sheet status**

Data sheet status	Product status	Definition [1]
Objective specification	Development	This data sheet contains the design target or goal specifications for product development. Specification may change in any manner without notice.
Preliminary specification	Qualification	This data sheet contains preliminary data, and supplementary data will be published at a later date. Philips Semiconductors reserves the right to make changes at any time without notice in order to improve design and supply the best possible product.
Product specification	Production	This data sheet contains final specifications. Philips Semiconductors reserves the right to make changes at any time without notice in order to improve design and supply the best possible product.

[1] Please consult the most recently issued datasheet before initiating or completing a design.

Definitions

Short-form specification — The data in a short-form specification is extracted from a full data sheet with the same type number and title. For detailed information see the relevant data sheet or data handbook.

Limiting values definition — Limiting values given are in accordance with the Absolute Maximum Rating System (IEC 134). Stress above one or more of the limiting values may cause permanent damage to the device. These are stress ratings only and operation of the device at these or at any other conditions above those given in the Characteristics sections of the specification is not implied. Exposure to limiting values for extended periods may affect device reliability.

Application information — Applications that are described herein for any of these products are for illustrative purposes only. Philips Semiconductors make no representation or warranty that such applications will be suitable for the specified use without further testing or modification.

Disclaimers

Life support — These products are not designed for use in life support appliances, devices or systems where malfunction of these products can reasonably be expected to result in personal injury. Philips Semiconductors customers using or selling these products for use in such applications do so at their own risk and agree to fully indemnify Philips Semiconductors for any damages resulting from such application.

Right to make changes — Philips Semiconductors reserves the right to make changes, without notice, in the products, including circuits, standard cells, and/or software, described or contained herein in order to improve design and/or performance. Philips Semiconductors assumes no responsibility or liability for the use of any of these products, conveys no license or title under any patent, copyright, or mask work right to these products, and makes no representations or warranties that these products are free from patent, copyright, or mask work right infringement, unless otherwise specified.

Philips Semiconductors
811 East Arques Avenue
P.O. Box 3409
Sunnyvale, California 94088-3409
Telephone 800-234-7381

© Copyright Philips Electronics North America Corporation 1998
 All rights reserved. Printed in U.S.A.

Date of release: 05-98

Document order number:

9397 750 03853

Let's make things better.