

## DM74LS393 Dual 4-Bit Binary Counter

### General Description

Each of these monolithic circuits contains eight master-slave flip-flops and additional gating to implement two individual four-bit counters in a single package. The DM74LS393 comprises two independent four-bit binary counters each having a clear and a clock input. N-bit binary counters can be implemented with each package providing the capability of divide-by-256. The DM74LS393 has parallel outputs from each counter stage so that any submultiple of the input count frequency is available for system-timing signals.

### Features

- Dual version of the popular DM74LS93
- DM74LS393 dual 4-bit binary counter with individual clocks
- Direct clear for each 4-bit counter
- Dual 4-bit versions can significantly improve system densities by reducing counter package count by 50%
- Typical maximum count frequency 35 MHz
- Buffered outputs reduce possibility of collector commutation

### Ordering Code:

| Order Number | Package Number | Package Description   |
|--------------|----------------|---|
| DM74LS393M   | M14A           | 14-Lead Small Outline Integrated Circuit (SOIC), JEDEC MS-120, 0.150 Narrow |
| DM74LS373N   | N14A           | 14-Lead Plastic Dual-In-Line Package (PDIP), JEDEC MS-001, 0.300 Wide       |

Devices also available in Tape and Reel. Specify by appending the suffix letter "X" to the ordering code.

### Connection Diagram

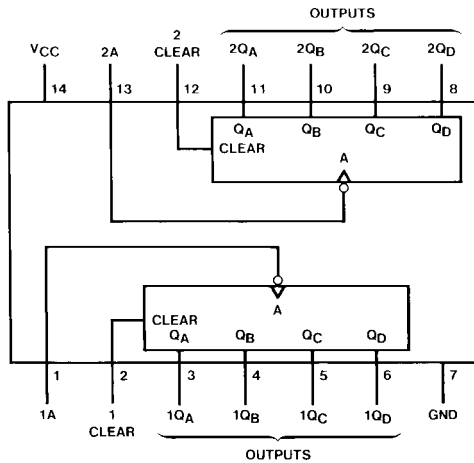

### Function Table

Counter Sequence (Each Counter)

| Count | Outputs        |                |                |                |
|-------|----------------|----------------|----------------|----------------|
|       | Q <sub>D</sub> | Q <sub>C</sub> | Q <sub>B</sub> | Q <sub>A</sub> |
| 0     | L              | L              | L              | L              |
| 1     | L              | L              | L              | H              |
| 2     | L              | L              | H              | L              |
| 3     | L              | L              | H              | H              |
| 4     | L              | H              | L              | L              |
| 5     | L              | H              | L              | H              |
| 6     | L              | H              | H              | L              |
| 7     | L              | H              | H              | H              |
| 8     | H              | L              | L              | L              |
| 9     | H              | L              | L              | H              |
| 10    | H              | L              | H              | L              |
| 11    | H              | L              | H              | H              |
| 12    | H              | H              | L              | L              |
| 13    | H              | H              | L              | H              |
| 14    | H              | H              | H              | L              |
| 15    | H              | H              | H              | H              |

H = HIGH Logic Level  
L = LOW Logic Level

### Logic Diagram

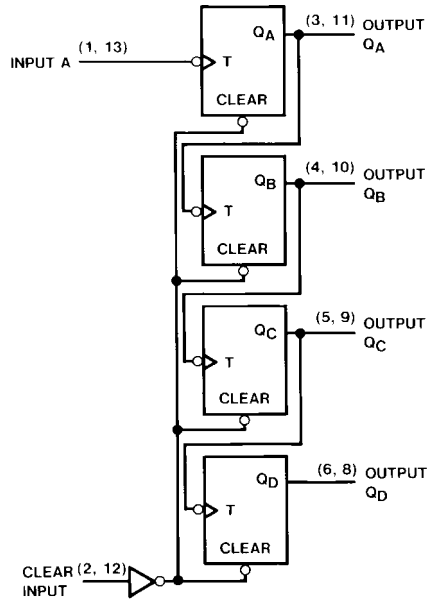

**Absolute Maximum Ratings**(Note 1)

|                                      |                 |
|--------------------------------------|-----------------|
| Supply Voltage                       | 7V              |
| Input Voltage                        |                 |
| Clear                                | 7V              |
| A                                    | 5.5V            |
| Operating Free Air Temperature Range | 0°C to +70°C    |
| Storage Temperature Range            | -65°C to +150°C |

**Note 1:** The "Absolute Maximum Ratings" are those values beyond which the safety of the device cannot be guaranteed. The device should not be operated at these limits. The parametric values defined in the Electrical Characteristics tables are not guaranteed at the absolute maximum ratings. The "Recommended Operating Conditions" table will define the conditions for actual device operation.

**Recommended Operating Conditions**

| Symbol           | Parameter                           | Min        | Nom | Max  | Units |
|------------------|-------------------------------------|------------|-----|------|-------|
| V <sub>CC</sub>  | Supply Voltage                      | 4.75       | 5   | 5.25 | V     |
| V <sub>IH</sub>  | HIGH Level Input Voltage            | 2          |     |      | V     |
| V <sub>IL</sub>  | LOW Level Input Voltage             |            |     | 0.8  | V     |
| I <sub>OH</sub>  | HIGH Level Output Current           |            |     | -0.4 | mA    |
| I <sub>OL</sub>  | LOW Level Output Current            |            |     | 8    | mA    |
| f <sub>CLK</sub> | Clock Frequency (Note 2)            | 0          |     | 25   | MHz   |
| f <sub>CLK</sub> | Clock Frequency (Note 3)            | 0          |     | 20   | MHz   |
| t <sub>w</sub>   | Pulse Width (Note 5)                | A          | 20  |      | ns    |
|                  |                                     | Clear HIGH | 20  |      |       |
| t <sub>REL</sub> | Clear Release Time (Note 4)(Note 5) | 25↓        |     |      | ns    |
| T <sub>A</sub>   | Free Air Operating Temperature      | 0          |     | 70   | °C    |

**Note 2:** C<sub>L</sub> = 15 pF, R<sub>L</sub> = 2 kΩ, T<sub>A</sub> = 25°C and V<sub>CC</sub> = 5V.

**Note 3:** C<sub>L</sub> = 50 pF, R<sub>L</sub> = 2 kΩ, T<sub>A</sub> = 25°C and V<sub>CC</sub> = 5V.

**Note 4:** The symbol (↓) indicates that the falling edge of the clear pulse is used for reference.

**Note 5:** T<sub>A</sub> = 25°C, and V<sub>CC</sub> = 5V.

**Electrical Characteristics**

over recommended operating free air temperature range (unless otherwise noted)

| Symbol          | Parameter                         | Conditions   | Min   | Typ (Note 6) | Max  | Units |
|-----------------|-----------------------------------|--|-------|--------------|------|-------|
| V <sub>I</sub>  | Input Clamp Voltage               | V <sub>CC</sub> = Min, I <sub>I</sub> = -18 mA   |       |              | -1.5 | V     |
| V <sub>OH</sub> | HIGH Level Output Voltage         | V <sub>CC</sub> = Min, I <sub>OH</sub> = Max<br>V <sub>IL</sub> = Max, V <sub>IH</sub> = Min | 2.7   | 3.4          |      | V     |
| V <sub>OL</sub> | LOW Level Output Voltage          | V <sub>CC</sub> = Min, I <sub>OL</sub> = Max<br>V <sub>IL</sub> = Max, V <sub>IH</sub> = Min |       | 0.35         | 0.5  | V     |
|                 |                                   | I <sub>OL</sub> = 4 mA, V <sub>CC</sub> = Min  |       | 0.25         | 0.4  |       |
| I <sub>I</sub>  | Input Current @ Max Input Voltage | V <sub>CC</sub> = Max, V <sub>I</sub> = 7V   |       |              | 0.1  | mA    |
|                 |                                   | V <sub>CC</sub> = Max, V <sub>I</sub> = 5.5V   | Clear | A            | 0.2  |       |
| I <sub>IH</sub> | HIGH Level Input Current          | V <sub>CC</sub> = Max, V <sub>I</sub> = 2.7V   |       |              | 20   | μA    |
|                 |                                   |  | Clear | A            | 40   |       |
| I <sub>IL</sub> | LOW Level Input Current           | V <sub>CC</sub> = Max, V <sub>I</sub> = 0.4V   |       |              | -0.4 | mA    |
|                 |                                   |  | Clear | A            | -1.6 |       |
| I <sub>OS</sub> | Short Circuit Output Current      | V <sub>CC</sub> = Max (Note 7)   | -20   |              | -100 | mA    |
| I <sub>CC</sub> | Supply Current                    | V <sub>CC</sub> = Max (Note 8)   |       | 15           | 26   | mA    |

**Note 6:** All typicals are at V<sub>CC</sub> = 5V, T<sub>A</sub> = 25°C.

**Note 7:** Not more than one output should be shorted at a time, and the duration should not exceed one second.

**Note 8:** I<sub>CC</sub> is measured with all outputs open, both CLEAR inputs grounded following momentary connection to 4.5V, and all other inputs grounded.

## Switching Characteristics

at  $V_{CC} = 5V$  and  $T_A = 25^\circ C$

| Symbol    | Parameter  | From (Input)<br>To (Output) | $R_L = 2\text{ k}\Omega$ |     |                      |     | Units |
|-----------|--|-----------------------------|--------------------------|-----|----------------------|-----|-------|
|           |  |                             | $C_L = 15\text{ pF}$     |     | $C_L = 50\text{ pF}$ |     |       |
|           |  |                             | Min                      | Max | Min                  | Max |       |
| $f_{MAX}$ | Maximum Clock Frequency                            | A to $Q_A$                  | 25                       |     | 20                   |     | MHz   |
| $t_{PLH}$ | Propagation Delay Time<br>LOW-to-HIGH Level Output | A to $Q_A$                  |                          | 20  |                      | 24  | ns    |
| $t_{PHL}$ | Propagation Delay Time<br>HIGH-to-LOW Level Output | A to $Q_A$                  |                          | 20  |                      | 30  | ns    |
| $t_{PLH}$ | Propagation Delay Time<br>LOW-to-HIGH Level Output | A to $Q_D$                  |                          | 60  |                      | 87  | ns    |
| $t_{PHL}$ | Propagation Delay Time<br>HIGH-to-LOW Level Output | A to $Q_D$                  |                          | 60  |                      | 87  | ns    |
| $t_{PHL}$ | Propagation Delay Time<br>HIGH-to-LOW Level Output | Clear to Any Q              |                          | 39  |                      | 45  | ns    |

**Physical Dimensions** inches (millimeters) unless otherwise noted

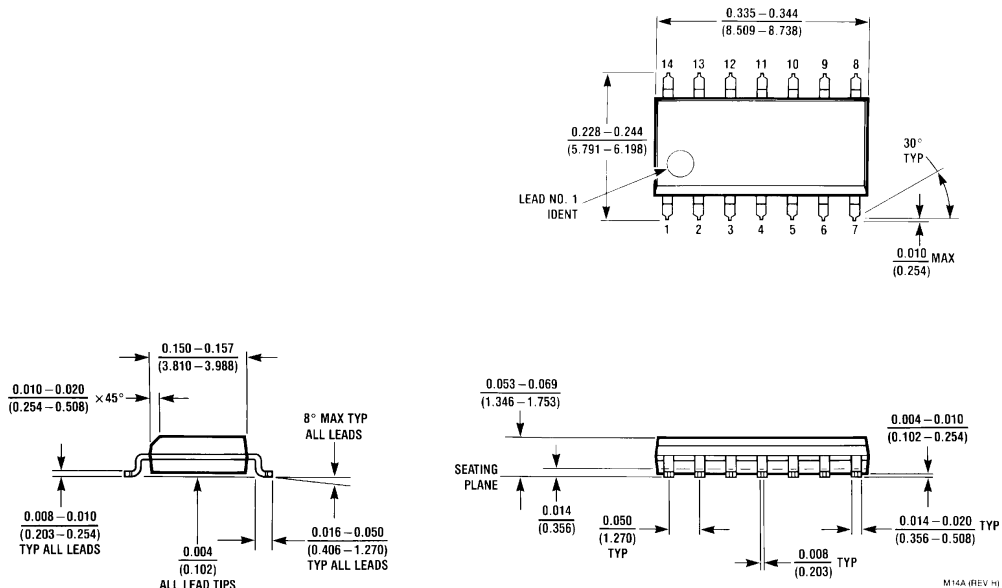

**14-Lead Small Outline Integrated Circuit (SOIC), JEDEC MS-120, 0.150 Narrow Package Number M14A**

**Physical Dimensions** inches (millimeters) unless otherwise noted (Continued)

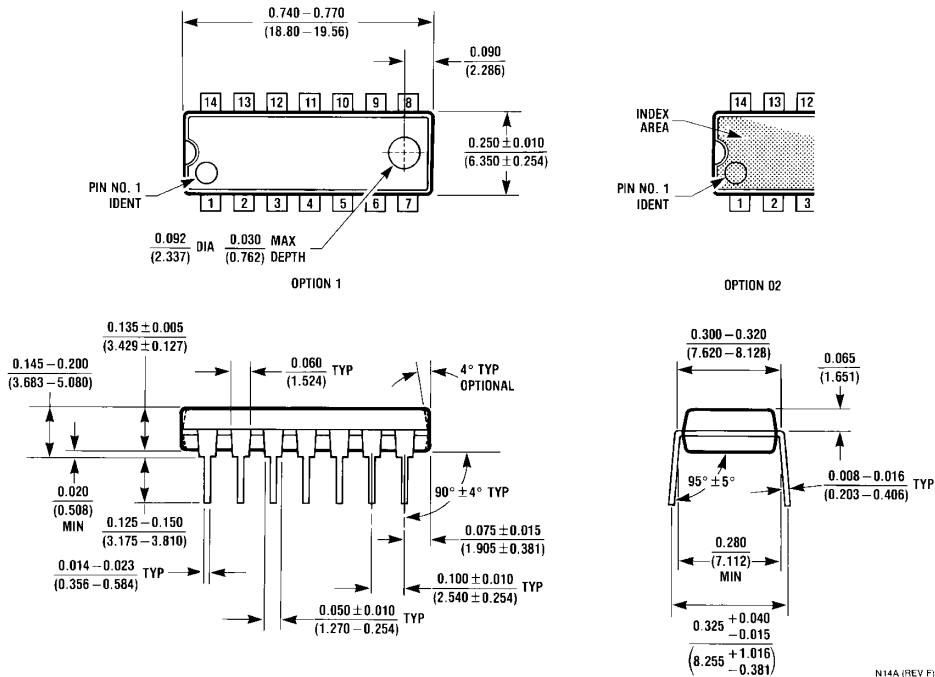

**14-Lead Plastic Dual-In-Line Package (PDIP), JEDEC MS-001, 0.300 Wide Package Number N14A**

Fairchild does not assume any responsibility for use of any circuitry described, no circuit patent licenses are implied and Fairchild reserves the right at any time without notice to change said circuitry and specifications.

**LIFE SUPPORT POLICY**

FAIRCHILD'S PRODUCTS ARE NOT AUTHORIZED FOR USE AS CRITICAL COMPONENTS IN LIFE SUPPORT DEVICES OR SYSTEMS WITHOUT THE EXPRESS WRITTEN APPROVAL OF THE PRESIDENT OF FAIRCHILD SEMICONDUCTOR CORPORATION. As used herein:

1. Life support devices or systems are devices or systems which, (a) are intended for surgical implant into the body, or (b) support or sustain life, and (c) whose failure to perform when properly used in accordance with instructions for use provided in the labeling, can be reasonably expected to result in a significant injury to the user.
2. A critical component in any component of a life support device or system whose failure to perform can be reasonably expected to cause the failure of the life support device or system, or to affect its safety or effectiveness.

[www.fairchildsemi.com](http://www.fairchildsemi.com)