

Multifunctional Ignition and Injector Driver

The 33812 is an engine control analog power IC intended for motorcycle and other single/dual cylinder small engine control applications. The IC consists of three integrated low side drivers, one pre-driver, a +5.0 V, voltage pre-regulator, an MCU watchdog circuit, an ISO 9141 K-Line interface, and a parallel interface for MCU communication. The three low side drivers are provided for driving a fuel injector, a lamp or LED, and a relay or other load. The pre-driver is intended to drive either an Insulated Gate Bipolar Transistor (IGBT) or a bipolar Darlington transistor to control an ignition coil.

Features:

- Designed to operate over the range of $\sim 4.7\text{ V} \leq V_{PWR} \leq 36\text{ V}$
- Fuel Injector driver - Current Limit - 4.0 A Typical
- Ignition pre-driver can drive IGBT or Darlington bipolar junction transistors
- Ignition pre-driver has independent high and low side outputs
- Relay driver - Current Limit - 4.0 A Typical
- Lamp driver- Current Limit - 1.5 A Typical
- All external outputs protected against short to battery, over-current
- Ignition and other drivers protected against over-temperature
- Interfaces directly to MCU Using 5.0 V parallel interface
- VCC voltage pre-regulator provides +5.0 V power for the MCU
- MCU Power On $\overline{\text{RESET}}$ generator
- MCU watchdog timer circuit with parallel refresh/time setting line
- Independent fault annunciation outputs for ignition, injector and relay drivers
- ISO-9141 K-Line transceiver for communicating diagnostic messages
- Pb-free packaging designated by suffix code EK

33812

SMALL ENGINE CONTROL IC



ORDERING INFORMATION

Device	Temperature Range (T _A)	Package
MCZ33812EK/R2	-40° to 125°C	32 SOICW-EP
*MCZ33812AEK/R2		

*Note: AEC qualified for automotive applications

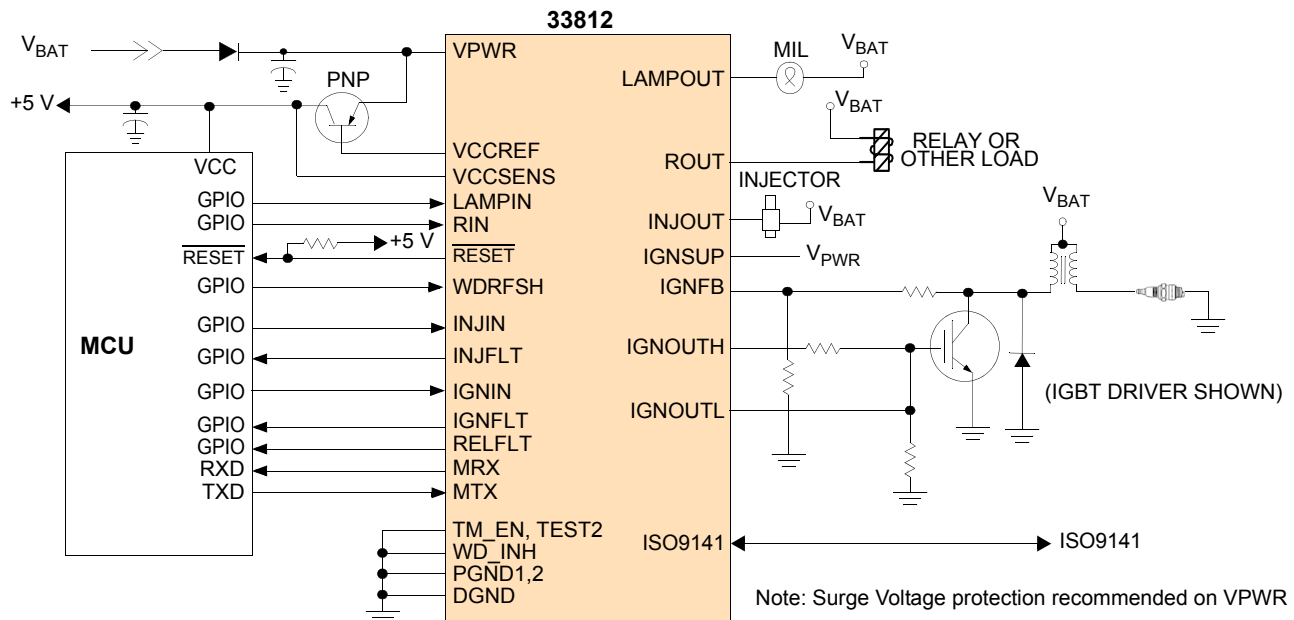

Figure 1. 33812 Simplified Application Diagram

* This document contains certain information on a new product. Specifications and information herein are subject to change without notice.

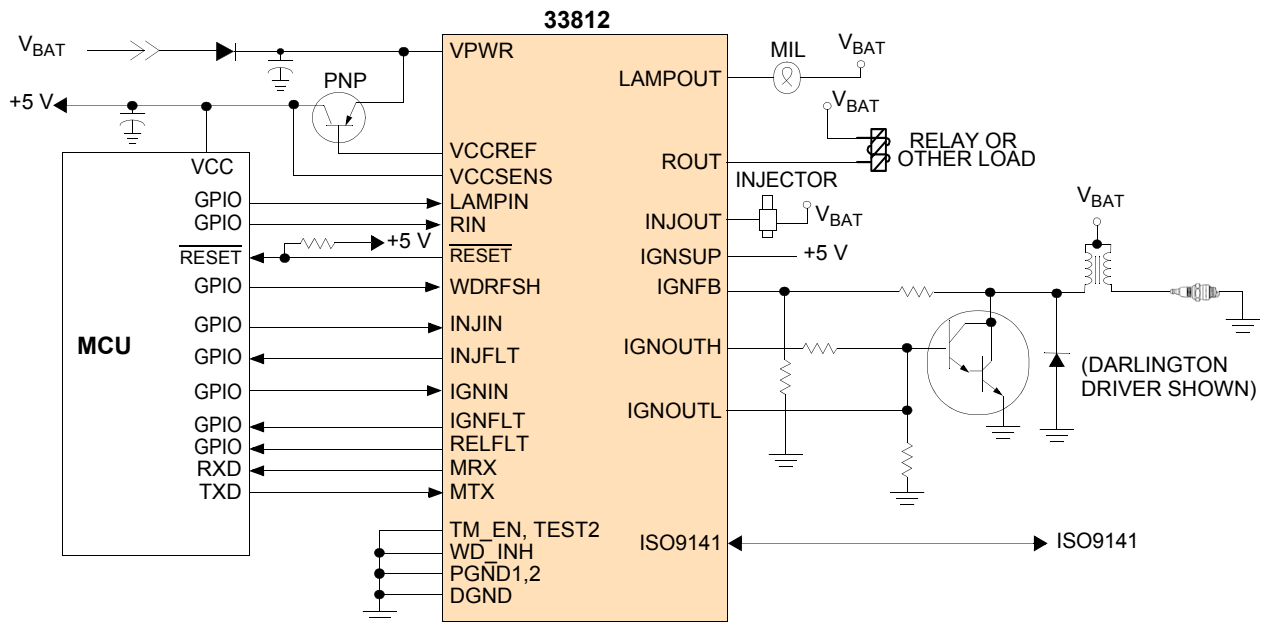

Figure 2. 33812 Simplified Application Diagram (Darlington Mode)

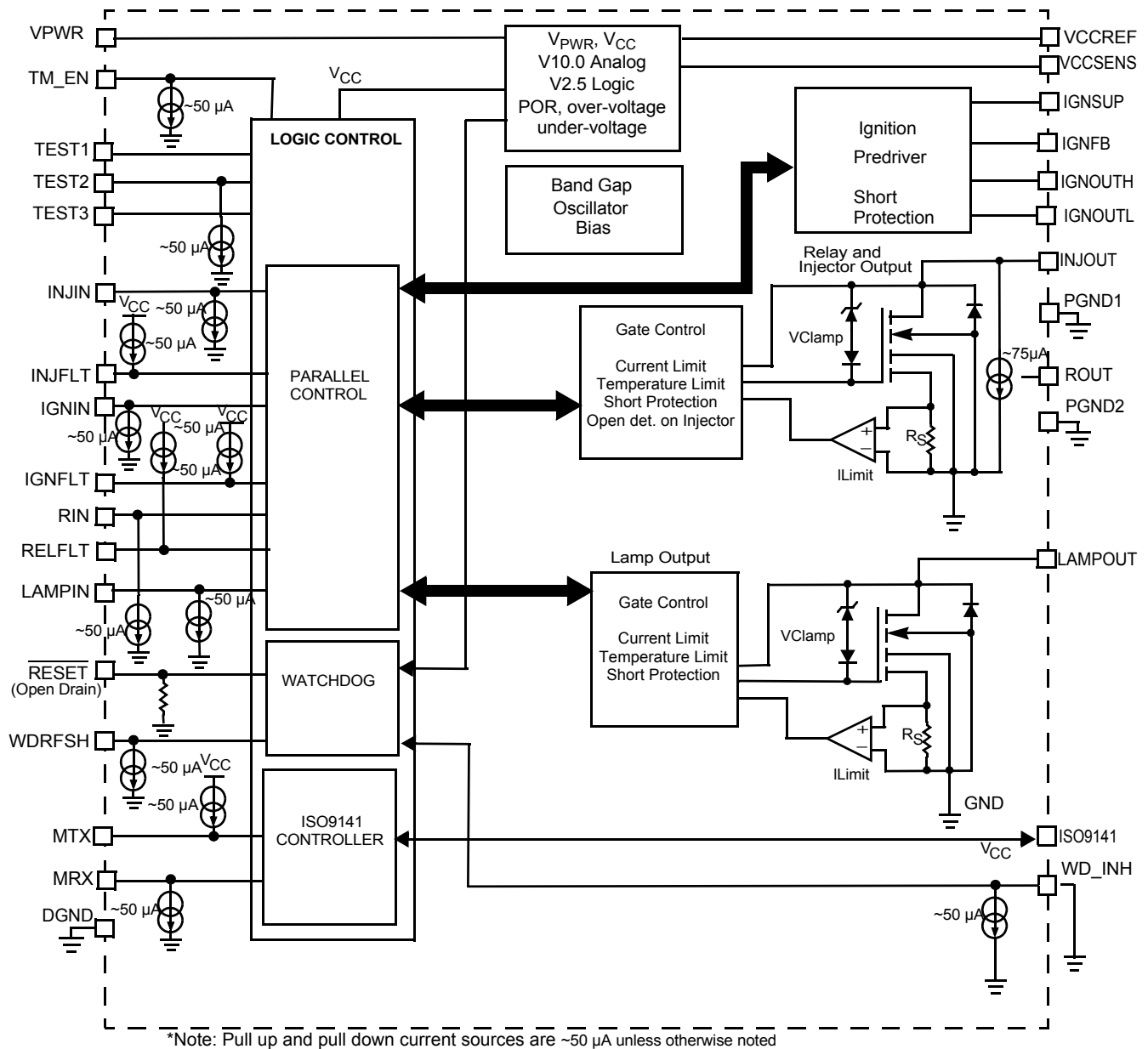

Figure 3. 33812 Simplified Internal Block Diagram

PIN CONNECTIONS

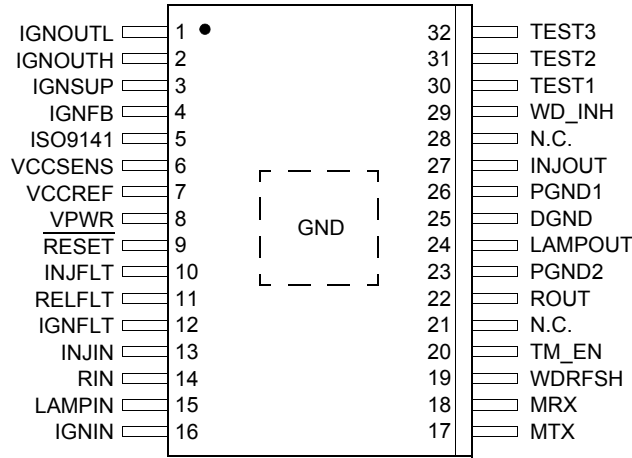

Figure 4. 33812 Pin Connections

Table 1. 33812 Pin Definitions

Pin	Pin Name	Pin Function	Formal Name	Description
1	IGNOUTL	Output	Ignition Output Low	Low side output to drive Gate/Base of IGBT/Bipolar Darlington
2	IGNOUTH	Output	Ignition Output High	High side output to drive Gate/Base of IGBT/Bipolar Darlington
3	IGNSUP	Input	Ignition Output Supply	Tie to +5 V for Darlington, tie to the V_{PWR} supply for IGBT output device
4	IGNFB	Input	Feedback from Source	Voltage feedback from source of Ignition driver transistor through 10:1 voltage divider
5	ISO9141	Input/Output	ISO9141 K-Line Bidirectional Serial Data Signal	The ISO9141 pin is V_{PWR} level IN/OUT signal connected to external ECU Tester using ISO9141 Protocol. The Output is Open drain and the Input is a ratiometric V_{PWR} level threshold comparator
6	VCCSENS	Input	Voltage Sense from VCC	Feedback to internal VCC regulator from external pass transistor
7	VCCREF	Output	VCC Reference Base drive	Base drive voltage for external PNP pass transistor
8	VPWR	Supply Input	Main Voltage Supply Input	VPWR is the main voltage supply Input for the device. Connected to +12 volt battery (It should have reverse battery protection and transient suppression.)
9	RESET	Output	Reset Output to MCU	Logic Level Reset signal used to reset the MCU when the watchdog circuit times out, during under voltage condition on VCC and for initial power up and power down
10	INJFLT	Output	Injector Fault	Logic Level output to MCU indicating any fault in the injector circuit.
11	RELFLT	Output	Relay Fault	Logic Level output to MCU indicating any fault in the relay circuit.
12	IGNFLT	Output	Ignition Fault	Logic Level output to MCU indicating any fault in the ignition circuit.
13	INJIN	Input	Injector Parallel Input	Logic Level input from the MCU to control the injector driver output
14	RIN	Input	Relay Parallel Input	Logic Level Parallel input to activate RELAY output, ROUT
15	LAMPIN	Input	LAMP Parallel Input	Logic Level Parallel input to activate the malfunction indicator lamp output, LAMP
16	IGNIN	Input	Ignition Parallel Input	Logic Level Input from MCU controlling the ignition coil current flow and spark.
17	MTX	Input	ISO9141 MCU Data Input	Input logic level ISO9141 data from the MCU to the ISO9141 IN/OUT pin

Table 1. 33812 Pin Definitions

Pin	Pin Name	Pin Function	Formal Name	Description
18	MRX	Output	Low Side Driver Output	Output logic level ISO9141 data to the MCU from the ISO9141 IN/OUT pin
19	WDRFSH	Input	Watchdog Refresh	Logic Level input from MCU to refresh the watchdog circuit to prevent RESET
20	TM_EN	Input	Test Mode Enable	Used by Freescale test engineering, tie to Gnd in operation
21	N.C.	Unused	-----	Unused pin, leave open
22	ROUT	Output	Relay Driver Output	Low side relay driver output driven by parallel input RIN
23	PGND2	Ground	Power Ground 2	Ground for RELAY driver output
24	LAMPOUT	Output	Warning Lamp Output	Low side driver output for MIL (warning lamp) driven by parallel input LAMPIN
25	DGND	Ground	Supply Ground	Tied to ground plane, used for ground for all low power signals
26	PGND1	Ground	Power Ground 1	Ground for INJOUT injector driver output
27	INJOUT	Output	Injector Driver Output	Low side driver output for Injector driven by parallel input INJIN
28	N.C.	Unused	-----	Unused pin, leave open
29	WD_INH	Input	Watch Dog Inhibit	Normally tied to GND, If tied high through a pull-up, it inhibits <u>RESET</u> from a watchdog time-out
30	TEST1	Input	Test 1	MUST be tied to GND.
31	TEST2	Input	Test 2	MUST be tied to GND.
32	TEST3	Input	Test 3	MUST leave OPEN.
EP	GND	Ground	Substrate Ground	Should be tied to DGND.

ELECTRICAL CHARACTERISTICS

MAXIMUM RATINGS

Table 2. Maximum Ratings

All voltages are with respect to ground, unless otherwise noted. Exceeding these ratings may cause a malfunction or permanent damage to the device.

Rating	Symbol	Value	Unit
VPWR Supply Voltage ⁽¹⁾	V _{PWR}	-0.3 to 45	V _{DC}
Logic Input Voltage (\overline{MTX} , INJIN, IGNIN, WDRFSH, LAMPIN, RIN)	V _{IL}	-0.3 to V _{CC}	V _{DC}
Injector and RELAY Low Side Driver Drain Voltage (V _{INJOUT})	V _{INJOUT} V _{RELOUT}	-0.3 to V _{CLAMP_INJ} -0.3 to V _{CLAMP_REL}	V _{DC}
Lamp Low Side Driver Drain Voltage (LAMP _{OUT})	LAMP _{OUT}	-0.3 to V _{CLAMP_LAMP}	V _{DC}
Output Clamp Energy (INJOUT and RO _{UT}) (Single Pulse) T _{JUNCTION} = 150°C, I _{OUT} = 1.5 A	E _{CLAMP_INJ_SP} E _{CLAMP_REL_SP}	100	mJ
Output Clamp Energy (INJOUT and RO _{UT}) (Continuous operation) T _{JUNCTION} = 125°C, I _{OUT} = 1.0 A, (Max. frequency is 70 Hz, Maximum Duty Cycle 90%)	E _{CLAMP_INJ_CP} E _{CLAMP_REL_CP}	100	mJ
Output Continuous Current (INJOUT and RO _{UT}) T _{JUNCTION} = 150°C	I _{OCC_MAX}	2.0	A
Output Clamp Energy (LAMP _{OUT}) (Single Pulse) - T _{JUNCTION} = 150°C, I _{OUT} = 0.5 A	E _{CLAMP_LAMP_SP}	35	mJ
ESD Voltage ⁽²⁾			V
Human Body Model	V _{ESD1}	±2000	
Machine Model	V _{ESD2}	±200	
Charge Device Model (Corner pins)	V _{ESD3}	±750	
Charge Device Model	V _{ESD4}	±500	

THERMAL RATINGS

Operating Temperature			°C
Ambient	T _A	-40 to 125	
Junction	T _J	-40 to 150	
Case	T _C	-40 to 125	
Storage Temperature	T _{STG}	-55 to 150	°C
Power Dissipation (T _A = 25°C) ⁽⁵⁾	P _D	1.7	W
Peak Package Reflow Temperature During Solder Mounting ^{(3), (4)}	T _{SOLDER}	Note 4	°C
Thermal Resistance			°C/W
Junction-to-Ambient	R _{θJA}	75	
Junction- to-Lead	R _{θJL}	8.0	
Junction-to-Flag	R _{θJC}	1.2	

Notes

- Exceeding these limits may cause malfunction or permanent damage to the device.
- ESD testing is performed in accordance with the Human Body Model (HBM) (C_{ZAP} = 100 pF, R_{ZAP} = 1500 Ω), the Machine Model (MM) (C_{ZAP} = 200 pF, R_{ZAP} = 0 Ω), and the Charge Device Model (CDM), Robotic (C_{ZAP} = 4.0 pF).
- Pin soldering temperature limit is for 10 seconds maximum duration. Not designed for immersion soldering. Exceeding these limits may cause malfunction or permanent damage to the device.
- Freescale's Package Reflow capability meets Pb-free requirements for JEDEC standard J-STD-020C. For Peak Package Reflow Temperature and Moisture Sensitivity Levels (MSL), Go to www.freescale.com, search by part number [e.g. remove prefixes/suffixes and enter the core ID to view all orderable parts (i.e. MC33xxxD enter 33xxx)], and review parametrics.
- This parameter is guaranteed by design but is not production tested.

STATIC ELECTRICAL CHARACTERISTICS

STATIC ELECTRICAL CHARACTERISTICS

Characteristics noted under conditions of $7.0\text{ V} \leq V_{\text{PWR}} \leq 18\text{ V}$, $-40^\circ\text{C} \leq T_{\text{C}} \leq 125^\circ\text{C}$, unless otherwise noted. Where applicable, typical values reflect the parameter's approximate average value with $V_{\text{PWR}} = 14\text{ V}$, $T_{\text{A}} = 25^\circ\text{C}$.

Characteristic	Symbol	Min	Typ	Max	Unit
----------------	--------	-----	-----	-----	------

POWER INPUT (VPWR)

Supply Voltage (measured at VPWR pin) ⁽⁷⁾					
Fully Operational	$V_{\text{PWR(FO)}}$	4.7	–	36	V
Full Parameter Specification	$V_{\text{PWR(FP)}}$	7.0		18	
Supply Current - All Outputs Disabled (Normal Mode)	$I_{\text{VPWR(ON)}}$	–	10.0	14.0	mA
V_{PWR} Over-voltage Shutdown Threshold Voltage ⁽⁸⁾	$V_{\text{PWR(OV)}}$	36.5	39	42	V
V_{PWR} Over-voltage Shutdown Hysteresis Voltage	$V_{\text{PWR(OV-HYS)}}$	0.5	1.5	3.0	V
V_{PWR} Under-voltage Shutdown Threshold Voltage ⁽⁸⁾	$V_{\text{PWR(UV)}}$	3.0	3.7	4.4	V
V_{PWR} Under-voltage Shutdown Hysteresis Voltage	$V_{\text{PWR(UV-HYS)}}$	100	200	300	mV

VOLTAGE REGULATOR OUTPUTS (VCCREF, VCCSENS)

VCCSENS (VCC) Output Voltage (measured with external output PNP (FZT753 typical) transistor and 500 Ω Load on VCCSENS)	V_{SENS}	4.9	5.0	5.1	V
VCCREF Output Current ⁽⁹⁾	I_{VCCREF}	–	-5.0	–	mA
VCCREF Current Limit	I_{VCCCL}	5.0	15	20	mA
Output Capacitance External (ceramic, low ESR recommended)	V_{OCE}	2.2	–	–	μF
VCCSENS Input Current	I_{VCCSENS}	–	50	1000	μA
Line Regulation (external output PNP transistor and 500 Ω Load on VCCSENS)	$\text{REG}_{\text{LINE_VCC}}$	–	2	25	mV
Load Regulation (external output PNP transistor and 500 Ω Load on VCCSENS)	$\text{REG}_{\text{LOAD_VCC}}$	–	2	25	mV
Dropout Voltage (Minimal Input/Output Voltage at full load)	V_{DROPOUT}	–	46	200	mV
V_{CC} Under-voltage $\overline{\text{RESET}}$ Threshold Voltage	$\text{RESET}_{\text{UV_VCC}}$	4.5	4.7	4.9	V

LOW SIDE DRIVER (INJOUT AND ROUT)

Output Fault Detection Voltage Threshold ⁽¹⁰⁾	$V_{\text{OUT(FLT-TH)}}$	2.0	2.5	3.0	V
Outputs programmed OFF (Open Load, Injector/Relay)					
Outputs programmed ON (Short to Battery)					
Output OFF Open Load Detection Current (Injector/Relay)	$I_{\text{(OFF)OCO}}$				μA
$V_{\text{DRAIN}} = 18\text{ V}$, Outputs Programmed OFF		40	75	150	

Notes

- Device is functional provided T_{J} is less than 150°C . Some table parameters may be out of specification.
- Over-voltage thresholds minimum and maximum include hysteresis.
- Under-voltage thresholds minimum and maximum include hysteresis, for disabling outputs only, $\overline{\text{RESET}}$ based on VCC under-voltage
- This parameter is guaranteed by design, however is not production tested.
- Output fault detect thresholds are the same for output open and shorts.

STATIC ELECTRICAL CHARACTERISTICS (continued)

Characteristics noted under conditions of $7.0\text{ V} \leq V_{PWR} \leq 18\text{ V}$, $-40^\circ\text{C} \leq T_C \leq 125^\circ\text{C}$, unless otherwise noted. Where applicable, typical values reflect the parameter's approximate average value with $V_{PWR} = 14\text{ V}$, $T_A = 25^\circ\text{C}$.

Characteristic	Symbol	Min	Typ	Max	Unit
LOW SIDE DRIVER (INJOUT AND ROUT) (CONTINUED)					
Drain-to-Source ON Resistance $I_{OUT} = 1.0\text{ A}$, $T_J = 125^\circ\text{C}$, $V_{PWR} = 14\text{ V}$ $I_{OUT} = 1.0\text{ A}$, $T_J = 25^\circ\text{C}$, $V_{PWR} = 14\text{ V}$ $I_{OUT} = 1.0\text{ A}$, $T_J = -40^\circ\text{C}$, $V_{PWR} = 14\text{ V}$	$R_{DS(ON)-INJ/REL}$ $R_{DS(ON)-INJ/REL}$ $R_{DS(ON)-INJ/REL}$	– – –	– 0.25 0.2	0.4 – –	Ω
Output Self Limiting Current	$I_{OUT(LIM)-INJ/REL}$	3.0	–	6.0	A
Output Clamp Voltage - $I_D = 20\text{ mA}$	$V_{CLAMP_INJ/REL}$	48	53	58	V
Output Leakage Current (INJOUT) $V_{DRAIN} = 24\text{ V}$, (Note: Open Load Detection Current can't be disabled)	$I_{OUT(LKG)-INJ}$	–	–	1.0	mA
Output Leakage Current (ROUT) $V_{DRAIN} = 24\text{ V}$, (Note: Open Load Detection Current can't be disabled)	$I_{OUT(LKG)-REL}$	–	–	1.0	mA
Over-temperature Shutdown ⁽¹¹⁾	$T_{LIM-INJ/REL}$	155	–	190	$^\circ\text{C}$
Over-temperature Shutdown Hysteresis ⁽¹¹⁾	$T_{LIM(HYS)-INJ/REL}$	5.0	10	15	$^\circ\text{C}$

LOW SIDE DRIVER (LAMP OUT)

Drain-to-Source ON Resistance $I_{OUT} = 300\text{ mA}$, $T_J = 150^\circ\text{C}$, $V_{PWR} = 14\text{ V}$	$R_{DS(ON)LAMP}$	–	–	1.0	Ω
Output Self Limiting Current	$I_{OUT(LIM)-LAMP}$	1.0	–	2.5	A
Output Clamp Voltage - $I_D = 20\text{ mA}$	$V_{CLAMP-LAMP}$	48	53	58	V
Output Leakage Current ⁽¹¹⁾ $V_{DRAIN} = 24\text{ V}$, (Note: No Open Load Detection Current)	$I_{OUT(LKG)-LAMP}$	–	–	20	μA
Output Fault Detection Voltage Threshold ⁽¹¹⁾ Outputs programmed ON (Short to Battery)	$V_{OUT(FLT-TH)-LAMP}$	2.0	2.5	3.0	V
Over-temperature Shutdown ⁽¹¹⁾	$T_{LIM-LAMP}$	155	–	190	$^\circ\text{C}$
Over-temperature Shutdown Hysteresis ⁽¹¹⁾	$T_{LIM(HYS)-LAMP}$	5.0	10	15	$^\circ\text{C}$

Notes

11. This parameter is guaranteed by design, however is not production tested.

STATIC ELECTRICAL CHARACTERISTICS (continued)

Characteristics noted under conditions of $7.0\text{ V} \leq V_{PWR} \leq 18\text{ V}$, $-40^\circ\text{C} \leq T_C \leq 125^\circ\text{C}$, unless otherwise noted. Where applicable, typical values reflect the parameter's approximate average value with $V_{PWR} = 14\text{ V}$, $T_A = 25^\circ\text{C}$.

Characteristic	Symbol	Min	Typ	Max	Unit
IGNITION (IGBT/DARLINGTON) DRIVER PARAMETERS (IGNOUTL, IGNOUTH, IGNFB, IGNSUP)					
Drain-to-Source ON Resistance (IGNOUTL Output, Gate/Base Drive Turn Off Resistance)	$R_{DS_L(ON)}$	150	300	400	Ω
Drain-to-Source ON Resistance (IGNSUP to IGNOUTH Output, Gate/Base Drive Turn On Resistance)	$R_{DS_H(ON)}$	–	70	90	Ω
Ignition Output High Source Current (IGNOUTH)	$I_{GATEDRIVE_H}$	40	50	–	mA
Ignition Output High (IGNOUTH) Device Power Dissipation ⁽¹²⁾	$PD_IGNOUTH$	–	–	300	mW
Output Fault Detection Voltage Threshold ⁽¹²⁾ (At IGNFB pin, not at input of 10:1 Voltage Divider) Output programmed OFF (Open Load) Output programmed ON (Short to Battery)	$V_{IGNFB_OUT(FLT-TH)}$	100	250	400	mV
Feedback Sense Current (FBx Input Current) FBx = 2.0 V, Output Programmed OFF	$I_{FBX(FLT-SNS)}$	–	–	1.0	μA
IGNSUP Voltage for: IGBT ⁽¹²⁾ Darlington ⁽¹²⁾	V_{IGNSUP_IGBT} V_{IGNSUP_DARL}	– –	V_{PWR} 5.0	V_{PWR_MAX} V_{CC_MAX}	V
Over-temperature Shutdown on IGNOUTH and IGNOUTL ⁽¹²⁾	$T_{LIM-IGNOUTH,L}$	155	–	190	$^\circ\text{C}$
Over-temperature Shutdown Hysteresis on IGNOUTH and IGNOUTL ⁽¹³⁾	$T_{LIM(HYS)-IGNOUTH,L}$	5.0	10	15	$^\circ\text{C}$

ISO9141 TRANSCEIVER PARAMETERS (ISO9141)

Input low voltage at ISO I/O pin	V_{IL_ISO}	–	–	$0.3 \times V_{PWR}$	V
Input high voltage at ISO I/O pin	V_{IH_ISO}	$0.7 \times V_{PWR}$	–	–	V
Input hysteresis at ISO I/O pin	V_{HYST_ISO}	$0.15 \times V_{PWR}$	–	–	
Output low voltage at ISO I/O pin	V_{OL_ISO}	–	–	$0.2 \times V_{PWR}$	V
Output high voltage at ISO I/O pin	V_{OH_ISO}	$0.8 \times V_{PWR}$	–	–	V
Output current limit at ISO I/O pin (MTX = 0)	I_{LIM_ISO}	50	100	150	mA
Load capacitance at ISO I/O pin ⁽¹³⁾	C_{L_ISO}	0.01	3.0	10	nF

DIGITAL OUTPUTS (MRX, IGNFLT, RELFLT, INJFLT)

Output Logic High-voltage Levelled $I_{OH}=1.0\text{ mA}$ load)	V_{OH}	$0.8 \times V_{CC}$	–	$V_{CC} + 0.2$	V
Output Logic Low-voltage Level (at $I_{OL}=1.0\text{ mA}$ load)	V_{OL}	GND	–	$0.1 \times V_{CC}$	V

DIGITAL OUTPUT ($\overline{\text{RESET}}$)

Resistance of Internal pull-down resistor on open drain $\overline{\text{RESET}}$ pin	$R_{\overline{\text{RESET}}}$	100	–	500	k Ω
---------------------------------------------------------------------------------------	-------------------------------	-----	---	-----	------------

Notes

- These parameters are guaranteed by design.
- This parameter is guaranteed by design, however it is not production tested.

STATIC ELECTRICAL CHARACTERISTICS (continued)

Characteristics noted under conditions of $7.0\text{ V} \leq V_{PWR} \leq 18\text{ V}$, $-40^\circ\text{C} \leq T_C \leq 125^\circ\text{C}$, unless otherwise noted. Where applicable, typical values reflect the parameter's approximate average value with $V_{PWR} = 14\text{ V}$, $T_A = 25^\circ\text{C}$.

Characteristic	Symbol	Min	Typ	Max	Unit
DIGITAL INPUTS (MTX, INJIN, IGNIN, LAMPIN, WDRFSH, RIN, WD_INH)					
Input Logic High-voltage Thresholds	V_{IH}	$0.7 \times V_{CC}$	–	$V_{CC} + 0.3$	V
Input Logic Low-voltage Thresholds	V_{IL}	$\text{GND} - 0.3$	–	$0.2 \times V_{CC}$	V
Input Logic Voltage Hysteresis	V_{IHYS}	0.5	–	1.5	V
Input Logic Capacitance ⁽¹⁴⁾	C_{IN}	–	–	20	pF
Input Logic Pull-down Current (all except MTX) - 0.8 V to 5.0 V	I_{LOGIC_PD}	30	50	100	μA
Input Logic Pull-up Current (MTX only) - 0.8 V to 5.0 V	I_{LOGIC_PU}	-30	-50	-100	μA

Notes

- 14. These parameters are guaranteed by design.

DYNAMIC ELECTRICAL CHARACTERISTICS

DYNAMIC ELECTRICAL CHARACTERISTICS

Characteristics noted under conditions of $7.0\text{ V} \leq V_{PWR} \leq 18\text{ V}$, $-40^\circ\text{C} \leq T_C \leq 125^\circ\text{C}$, unless otherwise noted. Where applicable, typical values reflect the parameter's approximate average value with $V_{PWR} = 14\text{ V}$, $T_A = 25^\circ\text{C}$.

Characteristic	Symbol	Min	Typ	Max	Unit
----------------	--------	-----	-----	-----	------

POWER INPUT

Required Low State Duration on VPWR for Under-voltage Detect $V_{PWR} \leq V_{PWR_UV}$ ⁽¹⁵⁾	t_{UV}	1.0	–	–	μs
------------------------------------------------------------------------------------------------------------	----------	-----	---	---	---------------

WATCHDOG TIMER

Maximum time value Watchdog can be loaded with	WD_{MAX}	–	–	10	s
Maximum WDRFSH pulse width to load full Watchdog time value	WD_{LOAD}	–	–	1.0	ms
Minimum pulse width on WDRFSH to refresh Watchdog timer	$WDRFSH_{MIN}$	1.0	–	–	μs
Reset Pulse Width when Watchdog times out	WD_{RESET}	100	–	–	μs

ISO9141 TRANSCEIVER

Typical ISO9141 Data Rate ⁽¹⁵⁾	ISO_{BR}	–	10	–	kbps
Turn OFF Delay MTX Input to ISO Output	t_{TXDF}	–	–	2.0	μs
Turn ON/OFF Delay ISO Input to MRX Output	t_{RXDF} , t_{RXDR}	–	–	1.0	μs
Rise and Fall Time MRX Output (measured from 10% to 90%)	t_{RXR} , t_{RXF}	–	–	1.0	μs
Maximum Rise and Fall Time MTX Input (measured from 10% to 90%) ⁽¹⁵⁾	t_{TXR} , t_{TXF}	–	–	1.0	μs

LAMP DRIVER

Inrush Current Blanking Time (LAMP_OUT only)	$t_{OC(BLANK)}$	5.0	7.0	9.0	ms
LAMP_OUT, automatic retry timer during short to battery fault condition	t_{RETRY_LAMP}	7.0	10	13	ms

DIGITAL LOGIC OUTPUTS

INJFLT, IGNFLT Output Signal Rise Time ⁽¹⁵⁾	$t_{R(DLO)}$	–	100	200	ns
INJFLT, IGNFLT Output Signal Fall Time ⁽¹⁵⁾	$t_{F(DLO)}$	–	100	200	ns

INJECTOR AND RELAY DRIVER

Output ON Current Limit Fault Filter Timer	t_{SC}	30	60	90	μs
Output OFF Open Circuit Fault Filter Timer (INJECTOR and RELAY Driver)	$t_{(OFF)OC}$	100	–	400	μs
Output Slew Rate - Rise - $Z_{LOAD} = 14\ \Omega$, $V_{LOAD} = 14\text{ V}$	$t_{SR(RISE)}$	1.0	5.0	10	$\text{V}/\mu\text{s}$
Output Slew Rate - Fall - $Z_{LOAD} = 14\ \Omega$, $V_{LOAD} = 14\text{ V}$	$t_{SR(FALL)}$	1.0	5.0	10	$\text{V}/\mu\text{s}$

IGNITION PRE-DRIVER

Output OFF Open Circuit Fault Filter Timer	$t_{(OFF)OC}$	100	–	400	μs
Output ON Short-circuit to Battery Fault Detection Timer	$t_{(ON)(SC)}$	30	60	90	μs

Notes

15. This parameter is guaranteed by design, however is not production tested.

FUNCTIONAL DESCRIPTION

FUNCTIONAL PIN DESCRIPTION

SUPPLY INPUT (VPWR)

The VPWR pin is battery input to the 33812 IC. A POR/LVI sub-circuit monitors this input's voltage level. The VPWR pin requires external reverse battery and transient protection.

OUTPUT (VCCREF)

The VCCREF output pin is used to drive an external 5.0 V regulator PNP bipolar pass transistor.

INPUT (VCCSENS)

The VCCSENS pin is used to monitor the +5.0 Volts from the external pass transistor's output. A POR will be performed when the voltage on the VCCSENS pin goes from 0 to VCC.

DIGITAL GROUND (DGND)

The DGND pin provides ground reference for the digital inputs and outputs. The V_{CC} supply is referenced to the DGND pin.

PGND1 AND PGND2

The PGNDx pins provide power additional ground reference for the power outputs, ROUT, LAMPOUT, and INJOUT. The V_{PWR} supply is referenced to the PGND pins.

INJECTOR INPUT (INJIN)

The INJIN pin is the parallel input that controls the Injector output, INJOUT. The INJIN pin is a logic level input with built-in pull-down to ground to prevent accidental actuation of the injector if the connection to the pin is lost.

INJECTOR AND RELAY DRIVER OUTPUT (INJOUT/ROUT)

The INJOUT and ROUT output pin are the Injector driver and Relay driver outputs for the fuel Injector and Relay that this IC supports. The Relay Driver and Injector Drivers are identical in operation and features. The Injector driver output is controlled by the parallel input (INJIN) and the Relay driver output is controlled by the parallel input (RIN). The Injector and Relay outputs are turned off during VPWR over-voltage and under-voltage events. Open circuit (during off state), short to battery (during on state), and over-temperature faults are detected and annunciated as a logic high on the INJFLT and RELFLT lines. Over-current is limited by the current limiting circuitry but is not annunciated unless the over-current is due to a short to battery. For either driver, when a fault condition is detected, the driver will turn off, and when the fault condition clears, it will try to turn on again, if the input line goes low and then high.

LAMP DRIVER OUTPUT (LAMPOUT)

The LAMPOUT output pin is the lamp driver, a low side driver capable of driving an incandescent lamp. The current limit blanking time is set to allow the driver to handle the inrush current of a cold lamp filament. The LAMPOUT output is controlled by the parallel input pin (LAMPIN). The LAMPOUT low side driver is protected against over-temperature, and short to battery. Unlike the Injector driver, when a fault condition is detected, the LAMPOUT driver will turn off, but when the fault condition clears, it will turn on again, while the input line, LAMPIN is high.

PRE-DRIVER OUTPUT, WITH FEEDBACK AND SUPPLY VOLTAGE INPUT (IGNSUP, IGNOUTL, IGNOUTH, IGNFB)

The IGNOUTL and IGNOUTH output pins are the low side and high side output pins of the Ignition pre-driver. They are used to drive either an IGBT or a Darlington BJT to control the ignition coil current to produce a spark. The choice of output device, IGBT or Darlington Bipolar Junction Transistor, is indicated by the choice of supply voltage on the IGNSUP pin.

When driving a Darlington bipolar transistor, the IGNSUP line must be tied to the +5.0 V supply. When driving an IGBT, the IGNSUP may be tied to a protected voltage source (e.g. V_{PWR}) greater than +5.0 V to achieve the necessary gate drive voltage required by the IGBT. The high side output device will current limit if the circuit is forced to supply currents greater than the maximum indicated.

The IGNOUTL and IGNOUTH lines are controlled by the parallel input (IGNIN). The IGNOUT(L,H) outputs and the associated feedback pin, IGNFB, provide short to battery protection for the external driver transistor. A 10:1 voltage divider must be used on the feedback pin to prevent >400 Volt Ignition Coil flyback voltage from damaging the IC.

Open circuit (off state), short to battery (on state), and temperature limit threshold exceeded on the pre-driver stage are detected on the output, and all annunciated as a logic high on the IGNFLT line.

There is no individual annunciation of these three fault conditions. The IGNFLT line goes high when any of the three fault conditions are present.

If an over-current /short to battery fault condition, as defined by a V_{DS} greater than the $V_{IGNFB_OUT(FLT-TH)}$ is detected, the IGNOUTH or IGNOUTL will turn off and not turn on again until the fault condition has cleared and the IGNIN input line goes low and then high.

OUTPUTS (INJFLT, RELFLT, IGNFLT)

The INJFLT, RELFLT and IGNFLT pins are the logic level outputs that indicate when a fault condition has been detected on the INJOUT, ROUT or IGNOUT pins. These pins

are normally low and will go high when a fault is detected. Toggling the respective input pin will clear the respective fault pin if the fault has been cleared.

K-LINE COMMUNICATION (MTX, MRX, ISO9141)

These three pins are used to provide an ISO914, K-line communication link for the MCU to provide diagnostic support for the system. MRX is the +5.0 V logic level serial output line to the MCU. MTX is the +5.0 V logic level serial input to the IC from the MCU. The ISO9141 pin is a bidirectional line, consistent with the ISO9141 specification for signalling to and from the MCU.

RESET ($\overline{\text{RESET}}$)

The $\overline{\text{RESET}}$ pin is an open drain output. Without power on the circuit, $\overline{\text{RESET}}$ is held low by an internal pull-down resistor. When power is applied to the circuit and the voltage on the VCC_{SENSE} pin reaches the lower voltage threshold, (5.0 volts - 2% = 4.9 V) the $\overline{\text{RESET}}$ pin will remain at a low level (open drain FET turned on) for a period of time equal to the value WD_{RESET} . After this time period, the $\overline{\text{RESET}}$ pin will then go high and stay high until a watchdog $\overline{\text{RESET}}$ is generated, or an under-voltage event on VCC occurs. The

watchdog time and refresh features are controlled via the WDRFSH line.

RELOAD AND REFRESH TIME (WDRFSH)

The WDRFSH pin is an input that is supplied by an MCU output to set up the initial reload time, WD_{RELOAD} , and to refresh the watchdog timer. See the description of the watchdog timer for information on how to use this pin.

WATCHDOG INHIBIT (WD_INH)

The WD_INH , watchdog inhibit pin, is normally tied to ground. If desired, during software development, it can be lifted from the ground pad and pulled high through an external pull-up resistor. When high, WD_INH will prevent the watchdog timer from causing a $\overline{\text{RESET}}$ because of a watchdog timeout. The WD_INH should not be connected to an MCU I/O pin or left floating in normal operation.

TEST PINS (TEST1, TEST2, AND TEST3)

These three pins are used only by Freescale test engineering during the production testing of the 33812. They are not to be used for any application purpose and must be handled as specified in the pinout section of this document.

FUNCTIONAL DEVICE OPERATION

OPERATIONAL MODES

The 33812 has two states of operation, Normal state and Reset state.

RESET STATE

Applying V_{PWR} to the device will generate a Power On RESET (POR) placing the device in the $\overline{\text{RESET}}$ state. The Power On $\overline{\text{RESET}}$ circuit incorporates a timer to prevent high frequency transients from causing an erroneous POR.

An under-voltage condition on VCC will also place the device in the $\overline{\text{RESET}}$ state causing a $\overline{\text{RESET}}$ pulse to be generated on the $\overline{\text{RESET}}$ line.

All $\overline{\text{RESET}}$ s will pre-load the watchdog timer with the maximum time value, WD_{MAX} . The Watchdog will begin counting on the rising edge of the pulse.

NORMAL STATE

The NORMAL State is entered after the $\overline{\text{RESET}}$ line goes high.

Control register settings from $\overline{\text{RESET}}$ are as follows:

- All Outputs Off.
- Watchdog timer loaded with the WD_{MAX} time value.

Power Supply

The 33812 is designed to operate from 4.5 V to 36 V on the VPWR pin. The VPWR pin supplies power to all internal regulators, analog and logic circuit blocks. The VCCREF output pin controls an external PNP bipolar transistor, such that the collector is driven to +5.0 V +/- 2%. The VCCSENS input pin, connected to the collector of the PNP, is used to monitor the output voltage and provides the feedback to regulate the PNP collector to +5.0 V.

INJECTOR DRIVER OPERATION

The open drain Low Side Driver (LSD) INJOUT is designed to control a fuel injector. The Injector Driver is controlled through the logic level parallel input pin, INJIN. When INJIN is high, the INJOUT pin is pulled to ground, turning on the fuel injector. When INJIN is low, the injector pulls the INJOUT output to VBAT and the injector is turned off.

The INJOUT driver includes off state open load detection and its output device is protected against over-current, short to battery, over-temperature, inductive flyback over-voltage and VPWR over-voltage.

INJOUT Output Protection Features

Over-current ($I_{OUT-LIM}$)

The Injector Driver protection scheme uses three separate protection schemes to prevent damage to the output device.

The first protection scheme is deployed when an over-current event occurs. In this case the current limiting circuitry will attempt to limit the maximum current flow to the specified $I_{LIM-INJ}$ value.

Short to Battery

The second protection scheme is invoked when the over-current fault is due to a hard short to battery. In this case, the protection circuitry will, after the short detection filter time, turn off the output driver. The output will not try to turn on again until the INJIN input goes low and then high again.

A short to battery is reported as a high logic level on the INJFLT line.

Temperature Limit (T_{LIM})

The third protection scheme deals with the junction temperature of the output device. Any time the maximum temperature limit on the output device is exceeded (T_{LIM}), the device will shutdown until the junction temperature falls below this maximum temperature minus the hysteresis temperature value. The T_{LIM} hysteresis value is $T_{LIM(HYST)}$.

The maximum temperature (T_{LIM}) protection scheme controls the output device regardless of the state of the INJIN input. The device is unable to be activated until the junction temperature falls below this maximum temperature minus the hysteresis temperature value.

An over-temperature fault is also reported as a high logic level on the INJFLT line.

Over-voltage ($V_{CLAMP-INJ}$ and $V_{PWR(OV)}$)

The injector driver is also protected against two types of over-voltage conditions:

When the V_{PWR} supply exceeds the $V_{PWR(OV)}$ threshold, the INJOUT output turns off and stays off until the over-voltage condition abates and the INJIN input pin toggles low and then high again.

The output device controls inductive flyback voltages by an active clamping network that limits the voltage across the output device to $V_{CLAMP-INJ}$ volts.

INJOUT Fault Detection Features

Off State, Open Load Detection

An open load on the injector driver is detected by the voltage level on the drain of the output device in the off state. Internal to the device is a pull-down current source. In the event of an open injector the drain voltage is pulled low. When the voltage crosses the open load detection threshold, an open load is detected. The open load fault detect threshold is set internally and is not programmable. The open load fault is reported as a high logic level on the INJFLT line.

On State, Shorted Load Detection

The INJOUT driver is capable of detecting a shorted injector load (short to battery) in the on state. A shorted load

fault is reported when the drain pin voltage is greater than the preset short threshold voltage. The shorted load fault detect threshold is set internally and is not programmable. The shorted load fault is reported as a high logic level on the INJFLT line.

Clearing the INJFLT line

When the INJFLT line goes high for any of the following reasons, while the INJIN line is high (on state):

- Short to battery
- Over-temperature
- Over-voltage
- Open load

The INJFLT line will remain high until the INJIN line goes to a low logic level and then returns high (rising edge).

IGNITION PRE-DRIVER OPERATION

The Ignition pre-driver output is controlled by the logic level input IGNIN. When IGNIN is high the IGNOUTH pin is pulled high to IGNSUP. When the IGNIN pin is low, the IGNOUTL line is pulled to ground turning off the driver Darlington or IGBT. The IGNOUT pre-driver protects the output device against over-current, short to battery, and VPWR over-voltage.

IGNOUT OUTPUT PROTECTION FEATURES

Over-current and Short to battery (I_{LIM})

The Ignition Pre-driver protection scheme senses over-current in the driver device by monitoring the voltage at the IGNFB pin. Since this pin is protected by a 10:1 voltage divider, the over-current threshold voltage is set internally to 1/10 of the voltage expected on the drain or collector of the output device in an over-current situation. Since the Ignition output device is external to the 33812, a short to battery is the same as an over-current fault.

An over-current fault or short to battery is reported as a high logic level on the IGNFLT line.

Temperature Limit (T_{LIM})

Since the Ignition output device is external to the 33812, there is no over-temperature protection provided.

IGNOUT FAULT DETECTION FEATURES

Off State, Open Load Detection

An open load on the ignition driver external device is detected by the voltage level on the drain or collector of the

output device in the off state (through a 10:1 voltage divider). In the event of an open ignition coil the drain/collector voltage is pulled low. When the voltage crosses the open load detection threshold, an open load is detected. The open load fault detect threshold is set internally and is not programmable. An open load fault is reported as a high logic level on the IGNFLT line.

Over-voltage ($V_{PWR(OV)}$)

The Ignition pre-driver is also protected against an over-voltage condition:

When the VPWR supply exceeds the $V_{PWR(OV)}$ threshold, the IGNOUTL and IGNOUTH outputs turn off and stays off until the over-voltage condition clears and the next rising edge of the IGNIN input pin.

Clearing the IGNFLT line

When the IGNFLT line goes high for any of the following reasons, while the IGNIN line is high (on state):

- Short to battery
- Over-voltage
- Over-temperature of the IGNOUTL and IGNOUTH transistors
- Open load

The IGNFLT line will remain high until the IGNIN line goes to the low logic level and then returns high.

RELAY DRIVER OPERATION

The Relay Driver (ROUT) is a low side driver that is controlled by the logic level RIN input pin. When RIN is high, the ROUT pin is pulled to ground, turning on an external relay or other device. When RIN is low, the relay coil pulls the ROUT output to V_{BAT} , and the relay is turned off.

The ROUT driver includes off state open load detection and its output device is protected against over-current, short to battery, over-temperature, inductive flyback over-voltage and VPWR over-voltage.

The Relay Driver is functionally and electrically identical to the Injector driver and can be used as a second Injector driver, for two cylinder applications, as long as maximum power dissipation considerations are observed.

ROUT PROTECTION FEATURES

Over-current ($I_{OUT-LIM}$ ROUT)

The ROUT Driver protection scheme uses three separate protection schemes to prevent damage to the output device.

The first protection scheme is deployed when an over-current event occurs. In this case, the current limiting circuitry will attempt to limit the maximum current flow to the specified $I_{OUT-LIM-REL}$ value.

Short to Battery

The second protection scheme is invoked when the over-current fault is due to a hard short to battery. In this case, the protection circuitry will, after the short detection filter time, turn off the output driver. The output will not try to turn on again until the RIN input goes low and then high again.

A short to battery is reported as a high logic level on the RELFLT line.

Temperature Limit (T_{LIM})

The third protection scheme deals with the junction temperature of the output device. Any time the maximum temperature limit on the output device is exceeded (T_{LIM}), the device will shutdown until the junction temperature falls below this maximum temperature minus the hysteresis temperature value. The T_{LIM} hysteresis value is $T_{LIM(HYST)}$.

The maximum temperature (T_{LIM}) protection scheme controls the output device regardless of the state of the RIN input. The device is unable to be activated until the junction temperature falls below this maximum temperature minus the hysteresis temperature value.

An over-temperature fault is also reported as a high logic level on the RELFLT line.

Over-voltage ($V_{CLAMP-REL}$ and $V_{PWR(OV)}$)

The relay driver is also protected against two types of over-voltage conditions:

When the VPWR supply exceeds the $V_{PWR(OV)}$ threshold, the ROUT output turns off and stays off until the over-voltage condition abates and the RN input pin toggles low and then high again.

The output device is protected against inductive flyback voltages greater than $V_{CLAMP-REL}$ by an active clamping network that limits the voltage across the output device to $V_{CLAMP-REL}$ volts.

ROUT FAULT DETECTION FEATURES

Off State, Open Load Detection

An open load on the relay driver is detected by the voltage level on the drain of the output device in the off state. Internal to the device is a pull-down current source. In the event of an open injector the drain voltage is pulled low. When the voltage crosses the open load detection threshold, an open load is detected. The open load fault detect threshold is set internally and is not programmable. The open load fault is reported as a high logic level on the RELFLT line.

On State, Shorted Load Detection

The ROUT driver is capable of detecting a shorted load (short to battery) in the on state. A shorted load fault is reported when the drain pin voltage is greater than the preset short threshold voltage. The shorted load fault detect threshold is set internally and is not programmable. The shorted load fault is reported as a high logic level on the RELFLT line.

Clearing the RELFLT line

When the RELFLT line goes high for any of the following reasons, while the RIN line is high (on state):

- Short to battery
- Over-temperature
- Over-voltage
- Open load

The RELFLT line will remain high until the RIN line goes to a low logic level and then returns high (rising edge).

LAMP DRIVER OPERATION

The Lamp Driver is a low side driver that is controlled by the logic level LAMPIN input pin. When LAMPIN is high, the LAMP pin is pulled to ground, turning on an external bulb or LED. When LAMPIN is low, the bulb or LED pulls the LAMP output to V_{BAT} , and the lamp is turned off.

LAMP-OUT Protection Features

Over-current ($I_{OUT-LIM-LAMP}$)

The LAMP-OUT Driver protection scheme uses three separate protection schemes to prevent damage to the output device.

The first protection scheme is deployed when an over-current event occurs. In this case the current limiting circuitry will attempt to limit the maximum current flow to the specified $I_{OUT-LIM-LAMP}$ value.

Short to Battery

The second protection scheme is invoked when the over-current fault is due to a hard short to battery. In this case, the

protection circuitry will, after the short detection filter time, turn off the output driver.

There will be an internal retry timer to try to turn on again if the fault clears.

There is no annunciation of any LAMP-OUT faults.

Temperature Limit (T_{LIM})

The third protection scheme deals with the junction temperature of the output device. Any time the maximum temperature limit on the output device is exceeded (T_{LIM}), the device will shutdown until the junction temperature falls below this maximum temperature minus the hysteresis temperature value. The T_{LIM} hysteresis value is $T_{LIM(HYST)}$.

The maximum temperature (T_{LIM}) protection scheme controls the output device regardless of the state of the LAMPIN input. The device is unable to be activated until the junction temperature falls below this maximum temperature minus the hysteresis temperature value.

LAMP-OUT FAULT DETECTION FEATURES

Off State, Open Load Detection

Since there is no way to annunciate an open load fault for the lamp output driver, no open load fault detection is performed by the 33812.

On State, Shorted Load Detection

Even though there is no way to annunciate a shorted load fault for the lamp output driver, shorted fault detection is

performed by the 33812 as part of the protection for the output FET.

The LAMP-OUT driver also has an over-current blanking time of $t_{OC(BLANK)}$ to allow for incandescent lamp inrush current

OVER/UNDER-VOLTAGE SHUTDOWN STRATEGY

How the outputs behave after an over-voltage or under-voltage event on VPWR is listed in [Table 3](#) below:

Table 3. Over-voltage/Under-voltage Truth Table

Output	State Before OV or UV	State When Returning From Over-voltage	State When Returning From Under-voltage
INJOUT	X	OFF	OFF
IGNOUT	X	OFF	OFF
ROUT	OFF	OFF	OFF
ROUT	ON	ON	OFF
LAMP-OUT	OFF	OFF	OFF
LAMP-OUT	ON	ON	OFF

WATCHDOG TIMER OPERATION

The purpose of the watchdog timer is to provide a $\overline{\text{RESET}}$ to the MCU whenever the MCU is locked up in a loop or otherwise hung up, perhaps by executing erroneous code, such as a HALT instruction. The watchdog timer is initialized by a power on $\overline{\text{RESET}}$ or a $\overline{\text{RESET}}$ that occurs after a fault such as an under-voltage event on VCC.

Whenever the watchdog timer is refreshed, it is always reloaded with the value $\text{WD}_{\text{RELOAD}}$ which initially has a value of WD_{MAX} seconds. Whenever a $\overline{\text{RESET}}$ occurs, the $\text{WD}_{\text{RELOAD}}$ value is set to WD_{MAX} seconds and the watchdog timer is re-loaded with this value. When the $\overline{\text{RESET}}$ pulse returns high, and, if the WDRFSH line is low, the watchdog timer starts counting. If the watchdog timer reaches the WD_{MAX} value before the next rising edge on the WDRFSH line, the watchdog circuit will generate a $\overline{\text{RESET}}$ pulse to the MCU and reload itself with the maximum time value of $\text{WD}_{\text{RELOAD}}$, which will have been set back to WD_{MAX} seconds.

In normal operation, the MCU will issue a WDRFSH pulse, periodically, which re-loads the watchdog timer with the $\text{WD}_{\text{RELOAD}}$ value and starts the counting again, thus avoiding a watchdog timer generated $\overline{\text{RESET}}$ pulse. When the watchdog timer is refreshed by a WDRFSH pulse, before the watchdog timer reaches the programmed value, the refresh will prevent a $\overline{\text{RESET}}$ pulse from being issued to the MCU.

Loading the Watchdog Timer and $\text{WD}_{\text{RELOAD}}$

Aside from the $\overline{\text{RESET}}$ case, which always loads the $\text{WD}_{\text{RELOAD}}$ value and the watchdog timer with the maximum time value, WD_{MAX} , there is an additional way that the watchdog timer and the value $\text{WD}_{\text{RELOAD}}$ can be re-loaded.

During initialization, if the WDRFSH pulse width is greater than WD_{LOAD} , both the watchdog timer and the value $\text{WD}_{\text{RELOAD}}$ will be loaded with a timer count value, corresponding to the width of the pulse present on the WDRFSH input. Once this value is set, no further setting of the WD_{LOAD} value is possible until a $\overline{\text{RESET}}$ is performed.

Once the WDRFSH input goes low, the watchdog timer will begin incrementing again, counting up to the new value that has been loaded into the reload register. The watchdog must be refreshed by another pulse on the WDRFSH line, before the watchdog timer counts up to the reload value, or else a $\overline{\text{RESET}}$ pulse will be generated and sent to the MCU.

If the WDRFSH line is ever kept high for longer than $\text{WD}_{\text{RELOAD}}$ seconds, the watchdog will issue an immediate $\overline{\text{RESET}}$ to the MCU. Upon receiving a $\overline{\text{RESET}}$ input from the 33812, the MCU should always be programmed to bring the WDRFSH line low to avoid being locked in a “deadly embrace” condition where the MCU and 33812 alternate back and forth between the $\overline{\text{RESET}}$ and Normal states.

Disabling the Watchdog Timer

If the WD_INH line is pulled high through a pull-up resistor of 10 K or less, (i.e. not tied to ground), the watchdog timer

will be inhibited from issuing a $\overline{\text{RESET}}$ to the MCU, while the line is held in this state. This “watchdog Inhibited” state should only be used during software testing and development to avoid being concerned about an inadvertent watchdog $\overline{\text{RESET}}$.

Watchdog Timing Diagrams

Watchdog Loaded with WD_{MAX}

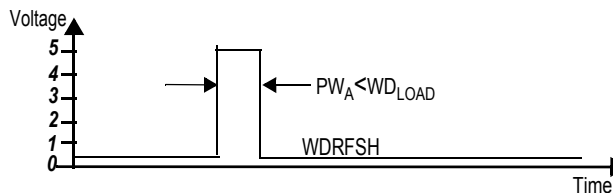
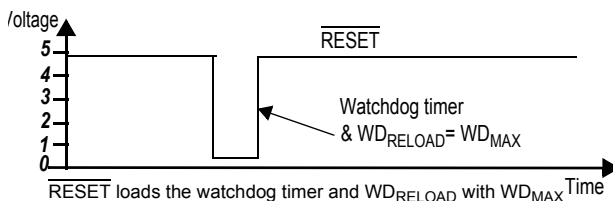
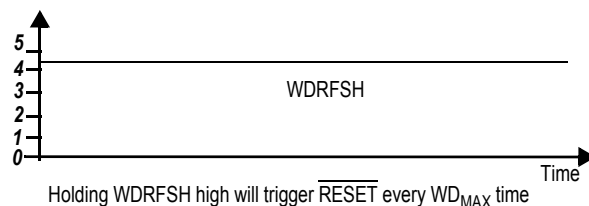

Refresh pulses, PW_A , on WDRFSH load the Watchdog timer with the $\text{WD}_{\text{RELOAD}}$

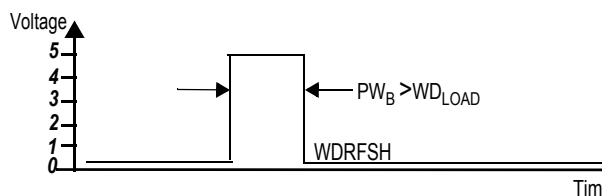

During initialization, for the first WDRFSH pulse only, PW_B , that is greater than WD_{LOAD} but less than WD_{MAX} , the Watchdog timer and $\text{WD}_{\text{RELOAD}}$ value will be loaded with a time value corresponding to the width of that pulse, PW_B . All pulses on the WDRFSH line width less than $\text{WD}_{\text{RELOAD}}$, will result in the Watchdog timer being reloaded with the time value corresponding to PW_B . This programmability is only allowed once per $\overline{\text{RESET}}$.

ISO-9141 TRANSCEIVER OPERATION

Bus I/O Pin (ISO9141)

This I/O pin represents the single-wire bus transmitter and receiver.

Transmitter Characteristics

The ISO-9141 bus transmitter is a low side MOSFET with internal over-current thermal shutdown. An internal pull-up resistor with a serial diode structure is integrated so no external pull-up components are required for the application in a slave node.

Voltage can go from -18 V to 40 V without current supplied from any other source than the pull-up resistance. The ISO9141 pin exhibits no reverse current from the ISO9141 bus line to VPWR, even in the event of GND shift or VPWR disconnection.

The transmitter has one slew rate (normal slew rate)

Receiver Characteristics

The receiver thresholds are ratiometric with the VPWR supply pin.

TYPICAL APPLICATIONS

Low Voltage Operation

During a low voltage condition ($4.5\text{ V} < \text{VPWR} < 9.0\text{ V}$) the device will operate as described in the functional description, however, certain parameters listed in the tables may be out of specification. Fault condition annunciation is not guaranteed below the minimum parametric operating voltage.

Low Side Injector Driver Voltage Clamp

The Injector output of the 33812 incorporates an internal voltage clamp to provide fast turn OFF and transient protection. Each clamp independently limits the drain-to-source voltage to $V_{\text{CLAMP_INJ}}$. The total energy clamped (E_J) can be calculated by multiplying the peak current (I_{PEAK}) times the clamp voltage (V_{CL}) times the Time (τ) all divided by 2 (see [Figure 5](#)).

Characterization of the output clamp, using a repetitive pulse method at 1.0 A, indicates the maximum energy to be 100 mJ at 125°C junction temperature per output

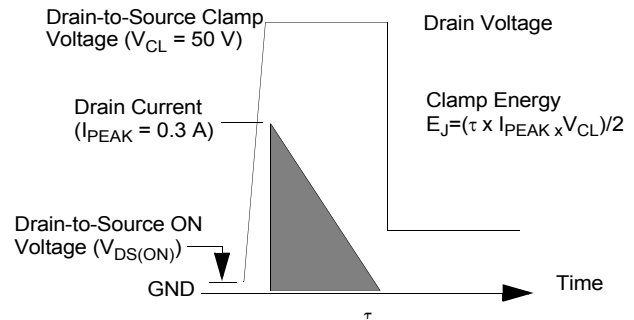

Figure 5. Output Voltage Clamping

Reverse Battery and Transient Protection

The 33812 device requires external reverse battery protection on the VPWR pin.

All outputs consist of a power MOSFET with an integral substrate diode. During a reverse battery condition, current will flow through the load via the substrate diode. Under this condition load devices will turn on. If reverse battery protection for the loads is required, a diode must be placed in series with the load.

Good automotive engineering practices recommend the use of transient voltage suppression on the VPWR line. A TVS device and adequate capacitive decoupling are necessary for a robust design.

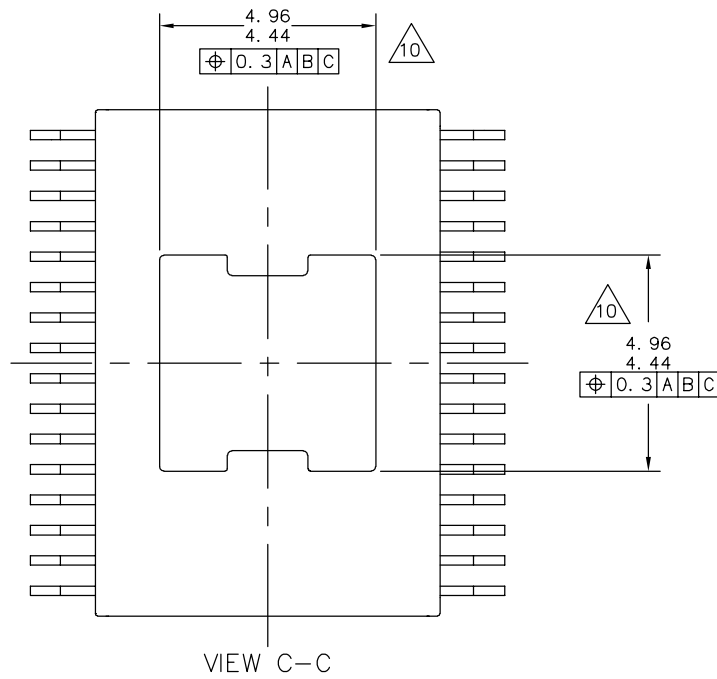
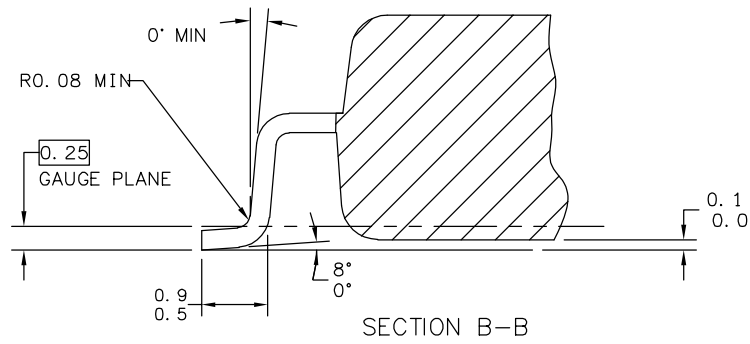

© FREESCALE SEMICONDUCTOR, INC. ALL RIGHTS RESERVED.	MECHANICAL OUTLINE	PRINT VERSION NOT TO SCALE	
TITLE: 32LD SOIC W/B, 0.65 PITCH 4.7 X 4.7 EXPOSED PAD, CASE-OUTLINE	DOCUMENT NO: 98ASA10556D	REV: D	
	CASE NUMBER: 1454-04	20 JUN 2008	
	STANDARD: NON-JEDEC		

EK SUFFIX
32-PIN
98ASA10556D
REVISION D

NOTES:

1. DIMENSIONS ARE IN MILLIMETERS.
2. DIMENSIONING AND TOLERANCING PER ASME Y14.5M-1994.
3. DATUMS B AND C TO BE DETERMINED AT THE PLANE WHERE THE BOTTOM OF THE LEADS EXIT THE PLASTIC BODY.
4. THIS DIMENSION DOES NOT INCLUDE MOLD FLASH, PROTRUSION OR GATE BURRS. MOLD FLASH, PROTRUSION OR GATE BURRS SHALL NOT EXCEED 0.15 MM PER SIDE. THIS DIMENSION IS DETERMINED AT THE PLANE WHERE THE BOTTOM OF THE LEADS EXIT THE PLASTIC BODY.
5. THIS DIMENSION DOES NOT INCLUDE INTER-LEAD FLASH OR PROTRUSIONS. INTER-LEAD FLASH AND PROTRUSIONS SHALL NOT EXCEED 0.25 MM PER SIDE. THIS DIMENSION IS DETERMINED AT THE PLANE WHERE THE BOTTOM OF THE LEADS EXIT THE PLASTIC BODY.
6. THIS DIMENSION DOES NOT INCLUDE DAMBAR PROTRUSION. ALLOWABLE DAMBAR PROTRUSION SHALL NOT CAUSE THE LEAD WIDTH TO EXCEED 0.4 mm. DAMBAR CANNOT BE LOCATED ON THE LOWER RADIUS OR THE FOOT. MINIMUM SPACE BETWEEN PROTRUSION AND ADJACENT LEAD SHALL NOT LESS THAN 0.07 mm.
7. EXACT SHAPE OF EACH CORNER IS OPTIONAL.
8. THESE DIMENSIONS APPLY TO THE FLAT SECTION OF THE LEAD BETWEEN 0.10 mm AND 0.3 mm FROM THE LEAD TIP.
9. THE PACKAGE TOP MAY BE SMALLER THAN THE PACKAGE BOTTOM. THIS DIMENSION IS DETERMINED AT THE OUTERMOST EXTREMES OF THE PLASTIC BODY EXCLUSIVE OF MOLD FLASH, TIE BAR BURRS, GATE BURRS AND INTER-LEAD FLASH, BUT INCLUDING ANY MISMATCH BETWEEN THE TOP AND BOTTOM OF THE PLASTIC BODY.
10. THESE DIMENSION RANGES DEFINE THE PRIMARY KEEP-OUT AREA. MOLD LOCKING AND RESIN BLEED CONTROL FEATURES MAY BE VISIBLE AND THEY MAY EXTEND TO 0.34mm FROM MAXIMUM EXPOSED PAD SIZE

© FREESCALE SEMICONDUCTOR, INC. ALL RIGHTS RESERVED.	MECHANICAL OUTLINE	PRINT VERSION NOT TO SCALE	
TITLE: 32LD SOIC W/B, 0.65 PITCH 4.7 X 4.7 EXPOSED PAD, CASE-OUTLINE	DOCUMENT NO: 98ASA10556D	REV: D	
	CASE NUMBER: 1454-04	20 JUN 2008	
	STANDARD: NON-JEDEC		

EK SUFFIX
32-PIN
98ASA10556D
REVISION D

REVISION HISTORY

REVISION	DATE	DESCRIPTION OF CHANGES
4.0	7/2009	<ul style="list-style-type: none">• Initial release
5.0	7/2010	<ul style="list-style-type: none">• Changed Part Number from PCZ33812AEK/R2 to MCZ33812AEK/R2

How to Reach Us:

Home Page:

www.freescale.com

Web Support:

<http://www.freescale.com/support>

USA/Europe or Locations Not Listed:

Freescale Semiconductor, Inc.
Technical Information Center, EL516
2100 East Elliot Road
Tempe, Arizona 85284
1-800-521-6274 or +1-480-768-2130
www.freescale.com/support

Europe, Middle East, and Africa:

Freescale Halbleiter Deutschland GmbH
Technical Information Center
Schatzbogen 7
81829 Muenchen, Germany
+44 1296 380 456 (English)
+46 8 52200080 (English)
+49 89 92103 559 (German)
+33 1 69 35 48 48 (French)
www.freescale.com/support

Japan:

Freescale Semiconductor Japan Ltd.
Headquarters
ARCO Tower 15F
1-8-1, Shimo-Meguro, Meguro-ku,
Tokyo 153-0064
Japan
0120 191014 or +81 3 5437 9125
support.japan@freescale.com

Asia/Pacific:

Freescale Semiconductor China Ltd.
Exchange Building 23F
No. 118 Jianguo Road
Chaoyang District
Beijing 100022
China
+86 10 5879 8000
support.asia@freescale.com

For Literature Requests Only:

Freescale Semiconductor Literature Distribution Center
P.O. Box 5405
Denver, Colorado 80217
1-800-441-2447 or +1-303-675-2140
Fax: +1-303-675-2150
LDCForFreescaleSemiconductor@hibbertgroup.com

Information in this document is provided solely to enable system and software implementers to use Freescale Semiconductor products. There are no express or implied copyright licenses granted hereunder to design or fabricate any integrated circuits or integrated circuits based on the information in this document.

Freescale Semiconductor reserves the right to make changes without further notice to any products herein. Freescale Semiconductor makes no warranty, representation or guarantee regarding the suitability of its products for any particular purpose, nor does Freescale Semiconductor assume any liability arising out of the application or use of any product or circuit, and specifically disclaims any and all liability, including without limitation consequential or incidental damages. "Typical" parameters that may be provided in Freescale Semiconductor data sheets and/or specifications can and do vary in different applications and actual performance may vary over time. All operating parameters, including "Typicals", must be validated for each customer application by customer's technical experts. Freescale Semiconductor does not convey any license under its patent rights nor the rights of others. Freescale Semiconductor products are not designed, intended, or authorized for use as components in systems intended for surgical implant into the body, or other applications intended to support or sustain life, or for any other application in which the failure of the Freescale Semiconductor product could create a situation where personal injury or death may occur. Should Buyer purchase or use Freescale Semiconductor products for any such unintended or unauthorized application, Buyer shall indemnify and hold Freescale Semiconductor and its officers, employees, subsidiaries, affiliates, and distributors harmless against all claims, costs, damages, and expenses, and reasonable attorney fees arising out of, directly or indirectly, any claim of personal injury or death associated with such unintended or unauthorized use, even if such claim alleges that Freescale Semiconductor was negligent regarding the design or manufacture of the part.



Freescale™ and the Freescale logo are trademarks of Freescale Semiconductor, Inc. All other product or service names are the property of their respective owners.

© Freescale Semiconductor, Inc., 2010. All rights reserved.

MC33812
Rev. 5.0
7/2010