

isc Silicon NPN Power Transistor

2SCR572D

DESCRIPTION

- Suitable for middle power drivers
- Low $V_{CE(sat)}$
 $V_{CE(sat)}=0.4V@(I_C=2A, I_B=0.1A)$
- Complementary NPN types:2SAR572D
- 100% avalanche tested
- Minimum Lot-to-Lot variations for robust device performance and reliable operation

APPLICATIONS

- Low frequency amplifier

ABSOLUTE MAXIMUM RATINGS(T_a=25°C)

SYMBOL	PARAMETER	VALUE	UNIT
V _{CBO}	Collector-Base Voltage	30	V
V _{CEO}	Collector-Emitter Voltage	30	V
V _{EBO}	Emitter-Base Voltage	6	V
I _C	Collector Current-Continuous	5	A
I _{CM}	Collector Current-Peak	10	A
P _C	Collector Power Dissipation @ T _C =25°C	10	W
T _J	Junction Temperature	150	°C
T _{stg}	Storage Temperature Range	-55~150	°C

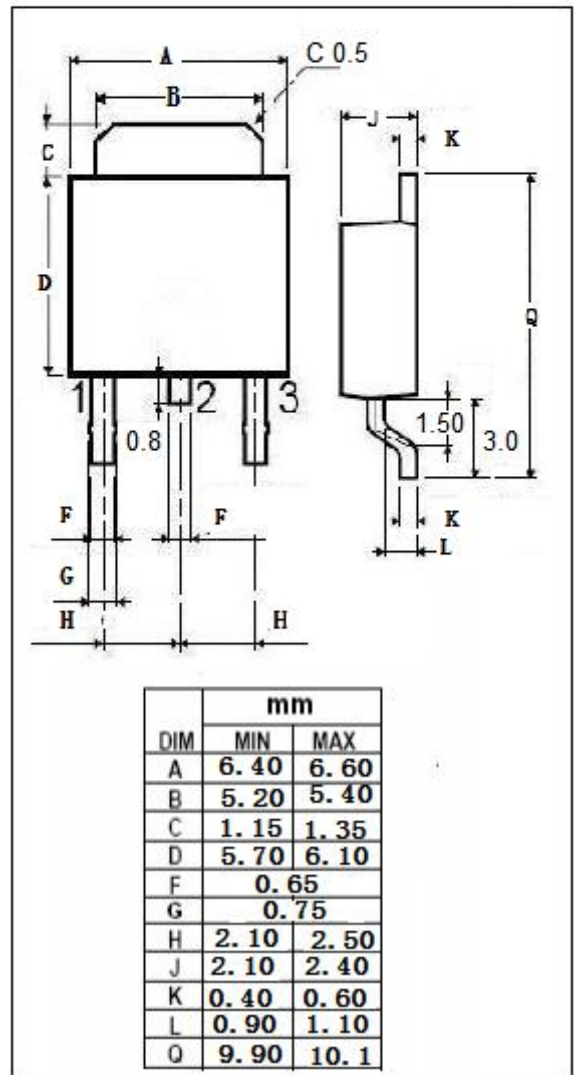
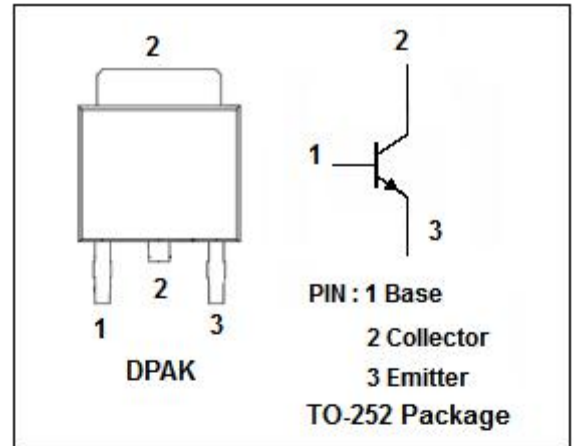

isc Silicon NPN Power Transistor**2SCR572D****ELECTRICAL CHARACTERISTICS**T_c=25°C unless otherwise specified

SYMBOL	PARAMETER	CONDITIONS	MIN	TYP.	MAX	UNIT
BV _{CBO}	Collector-Base breakdown voltage	I _C =100uA	30			V
BV _{CEO}	Collector-Emitter breakdown voltage	I _C =1mA	30			V
BV _{EBO}	Emitter-Base breakdown voltage	I _E =100uA	6			V
V _{CE(sat)}	Collector-Emitter Saturation Voltage	I _C = 2A; I _B = 100mA			0.4	V
I _{CBO}	Collector Cutoff Current	V _{CB} = 30V; I _E = 0			1.0	μ A
I _{EBO}	Emitter Cutoff Current	V _{EB} = 4V; I _C = 0			1.0	μ A
h _{FE}	DC Current Gain	I _C = 0.5A; V _{CE} = 3V	200		500	
C _{OB}	Output Capacitance	I _E = 0; V _{CB} = 10V; f= 1.0MHz		30		pF
f _T ^{NOTE}	Current-Gain—Bandwidth Product	I _C = 0.5A; V _{CE} = 10V,f= 100MHz		300		MHz

NOTE:Pulsed