

2SB1266

■ Features

- Suitable for sets whose height is restricted.
- High reliability.

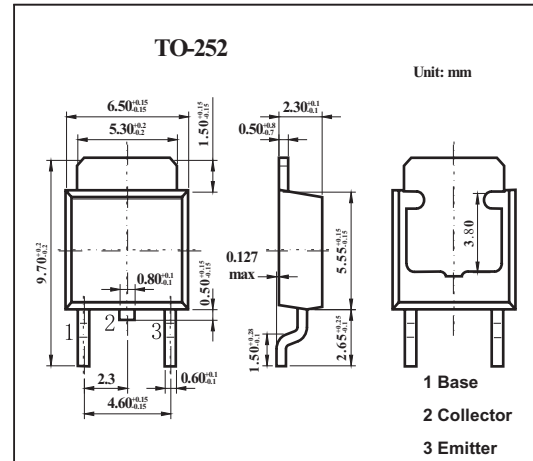

■ Absolute Maximum Ratings Ta = 25°C

Parameter	Symbol	Rating	Unit
Collector-base voltage	V _{CB0}	-60	V
Collector-emitter voltage	V _{CEO}	-60	V
Emitter-base voltage	V _{EBO}	-6	V
Collector current	I _C	-3	A
Collector current (pulse)	I _{CP}	-8	A
Collector dissipation	P _C	1.65	W
T _C = 25°C		30	W
Junction temperature	T _J	150	°C
Storage temperature	T _{stg}	-55 to +150	°C

■ Electrical Characteristics Ta = 25°C

Parameter	Symbol	Testconditions	Min	Typ	Max	Unit
Collector cutoff current	I _{CBO}	V _{CB} = -40V , I _E = 0			-100	μA
Emitter cutoff current	I _{EBO}	V _{EB} = -4V , I _C = 0			-100	μA
DC current Gain	h _{FE}	V _{CE} = -5V , I _C = -0.5A	70		280	
		V _{CE} = -5V , I _C = -3A	20			
Gain bandwidth product	f _T	V _{CE} = -5V , I _C = -0.5A		8		MHz
Output capacitance	C _{ob}	V _{CB} = -10V , f = 1MHz		60		pF
Collector-emitter saturation voltage	V _{CE(sat)}	I _C = -2A , I _B = -0.2A		-0.4	-1	V
Base-emitter voltage	V _{BE}	I _{CE} = -5V , I _C = -0.5A		-0.7	-1	V
Collector-to-base breakdown voltage	V _{(BR)CBO}	I _C = -1mA , I _E = 0	-60			V
Collector-to-emitter breakdown voltage	V _{(BR)CEO}	I _C = -5mA , R _{BE} = ∞	-60			V
Emitter-to-base breakdown voltage	V _{(BR)EBO}	I _E = -1mA , I _C = 0	-6			V

■ hFE Classification

Rank	Q	R	S
hFE	70~140	100~200	140~280