



Micro Commercial Components

Micro Commercial Components
20736 Marilla Street Chatsworth
CA 91311
Phone: (818) 701-4933
Fax: (818) 701-4939

2N6388

Features

- Lead Free Finish/RoHS Compliant (Note1) ("P" Suffix designates RoHS Compliant. See ordering information)
- Epoxy meets UL 94 V-0 flammability rating
- Moisture Sensitivity Level 1
- Marking: 2N6388

Maximum Ratings*

Symbol	Rating	Rating	Unit
V_{CEO}	Collector-Emitter Voltage	80	V
V_{CBO}	Collector-Base Voltage	80	V
V_{EBO}	Emitter-Base Voltage	5.0	V
I_C	Collector Current, Continuous Peak	10 15	A
I_B	Base Current	250	mA
T_J	Operating Junction Temperature	-55 to +150	°C
T_{STG}	Storage Temperature	-55 to +150	°C

Thermal Characteristics

Symbol	Rating	Max	Unit
P_D	Total Device Dissipation Derate above 25°C	65 0.52	W W/°C
P_D	Total Device Dissipation Derate above 25°C	2.0 0.016	W W/°C
R_{JC}	Thermal Resistance, Junction to Case	1.92	°C/W
R_{JA}	Thermal Resistance, Junction to Ambient	62.5	°C/W

Electrical Characteristics @ 25°C Unless Otherwise Specified

Symbol	Parameter	Min	Max	Units
--------	-----------	-----	-----	-------

OFF CHARACTERISTICS

$V_{CEO(sus)}$	Collector-Emitter Breakdown Voltage (Note 2) ($I_C=200mA$, $I_E=0$)	80	---	Vdc
I_{EO}	Collector Cutoff Current ($V_{CB}=80Vdc$, $I_E=0$)	---	1.0	mA
I_{EX}	Collector Cutoff Current ($V_{CE}=80Vdc$, $V_{EB(off)}=1.5Vdc$) ($V_{CE}=80Vdc$, $V_{EB(off)}=1.5Vdc$, $T_C=125°C$)	---	300 3.0	uA mA
I_{EO}	Emitter Cutoff Current ($V_{EB}=5.0Vdc$, $I_C=0$)	---	5.0	mA

ON CHARACTERISTICS⁽¹⁾

h_{FE}	DC Current Gain ($V_{CE}=3.0Vdc$, $I_C=5.0A$) ($V_{CE}=3.0Vdc$, $I_C=10A$)	1000 100	20000 ---	---
$V_{CE(sat)}$	Collector-Emitter Saturation Voltage ($I_C=5.0A$, $I_B=0.01A$) ($I_C=10A$, $I_B=0.1A$)	---	2.0 3.0	Vdc
$V_{BE(on)}$	Base-Emitter On Voltage ($I_C=5.0A$, $V_{CE}=3.0Vdc$) ($I_C=10A$, $V_{CE}=3.0Vdc$)	---	2.8 4.5	Vdc

*Indicates JEDEC Registered Data

Notes: 1. High Temperature Solder Exemption Applied, see EU Directive Annex 7.
2. Pulse Test: Pulse Width<300us, Duty Cycle<2.0%

NPN Darlington Power Transistor

TO-220

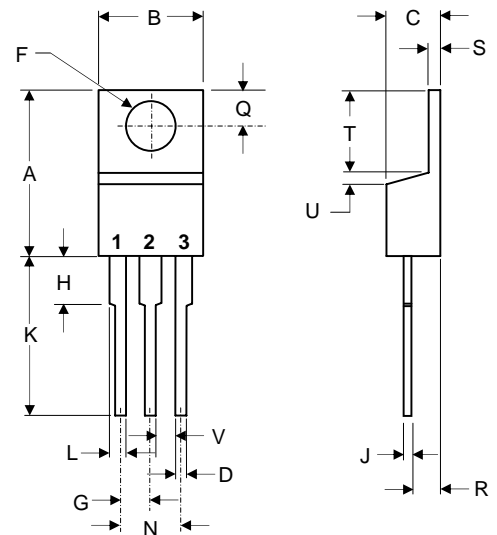

PIN 1. BASE
PIN 2. COLLECTOR
PIN 3. EMITTER

DIM	DIMENSIONS				NOTE
	INCHES		MM		
A	.560	.625	14.22	15.88	
B	.380	.420	9.65	10.67	
C	.140	.190	3.56	4.82	
D	.020	.045	0.51	1.14	
F	.139	.161	3.53	4.09	∅
G	.190	.110	2.29	2.79	
H	---	.250	---	6.35	
J	.012	.025	0.30	0.64	
K	.500	.580	12.70	14.73	
L	.045	.060	1.14	1.52	
N	.190	.210	4.83	5.33	
Q	.100	.135	2.54	3.43	
R	.080	.115	2.04	2.92	
S	.045	.055	1.14	1.39	
T	.230	.270	5.84	6.86	
U	---	.050	---	1.27	
V	.045	---	1.15	---	

2N6388

Symbol	Parameter	Min	Max	Units
DYNAMIC CHARACTERISTICS				
C_{cb}	Output Capacitance ($V_{CB}=10Vdc, f=1.0MHz$)	---	200	pF
h_{fe}	Small-Signal Current Gain ($I_C=1.0A_{dc}, V_{CE}=5.0Vdc, f=1.0MHz$)	1000	---	---
$ h_{fe} $	Small-Signal Current Gain ($I_C=1.0A_{dc}, V_{CE}=5.0Vdc, f=1.0KHz$)	20	---	---

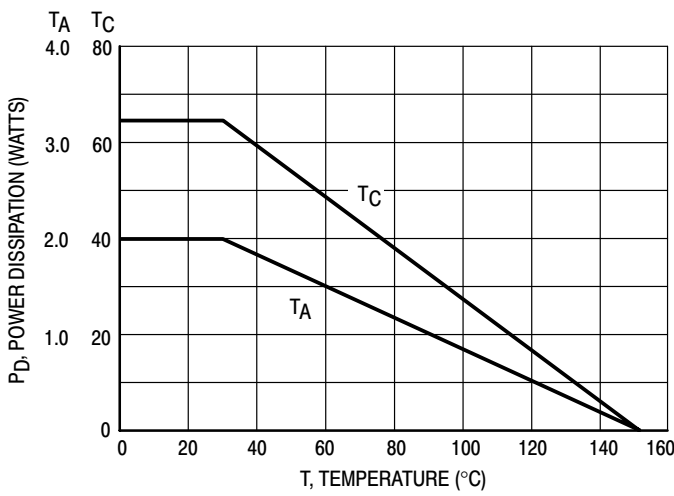

Figure 1. Power Derating

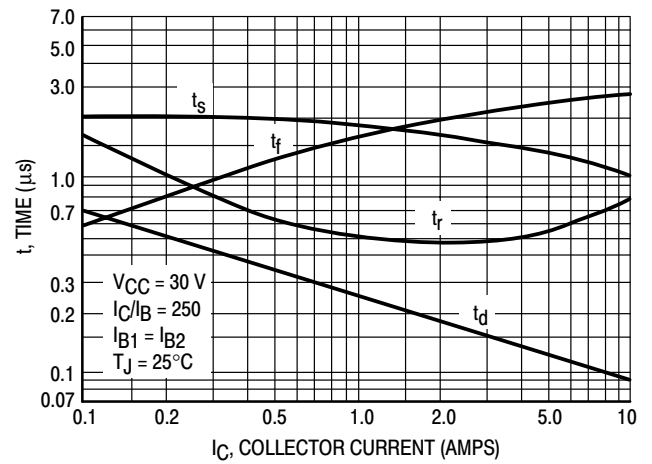

Figure 2. Switching Times

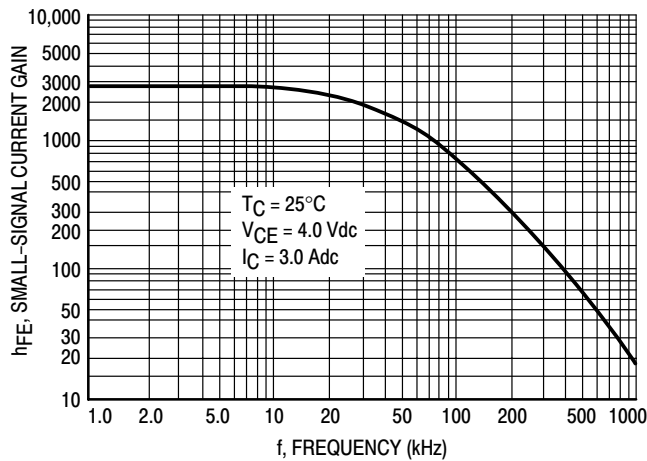

Figure 3. Small-Signal Current Gain

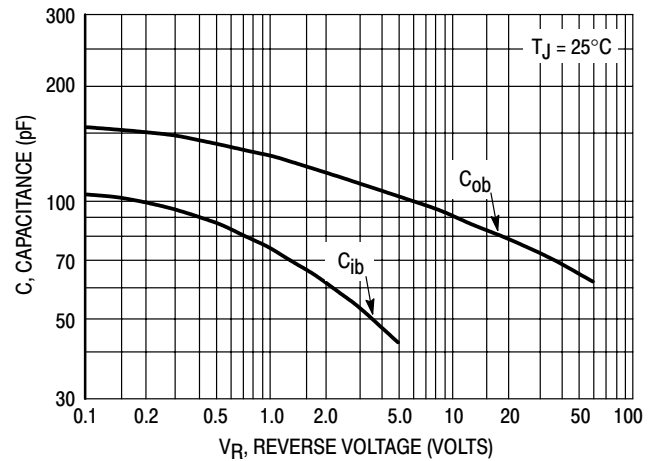

Figure 4. Capacitance

2N6388

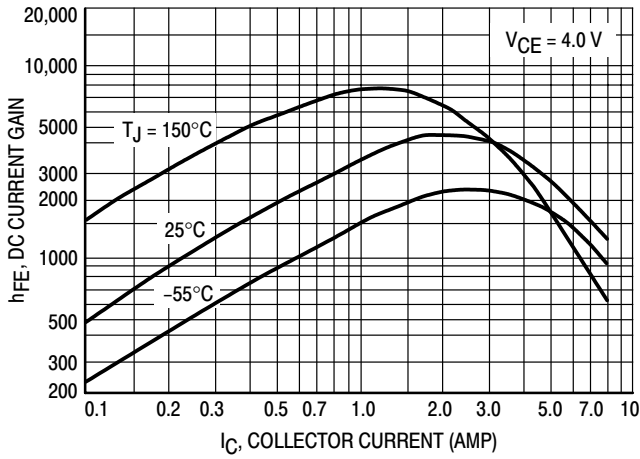

Figure 5. DC Current Gain

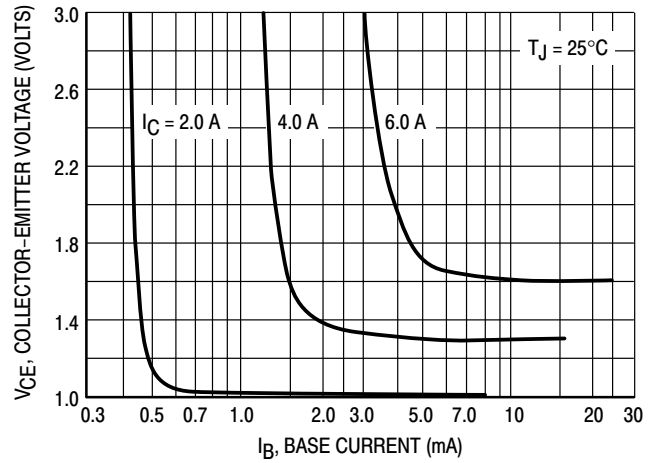

Figure 6. Collector Saturation Region

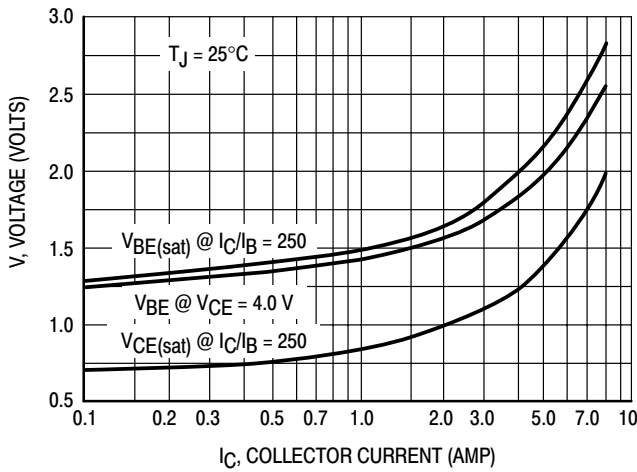

Figure 7. "On" Voltages

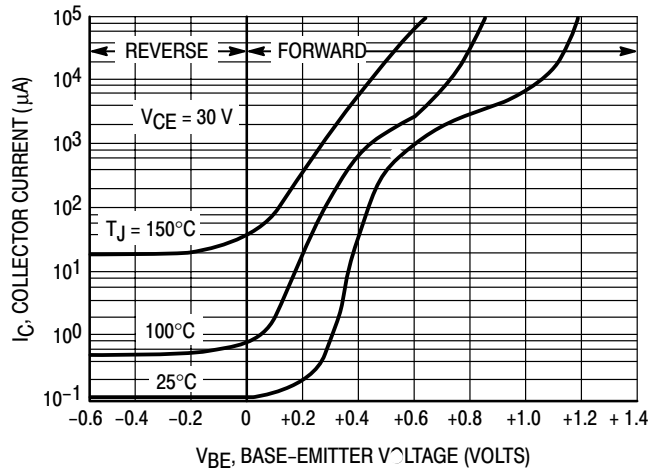

Figure 8. Collector Cut-Off Region



Micro Commercial Components

Ordering Information :

Device	Packing
Part Number-BP	Bulk; 1Kpcs/Box

*****IMPORTANT NOTICE*****

Micro Commercial Components Corp. reserves the right to make changes without further notice to any product herein to make corrections, modifications, enhancements, improvements, or other changes. **Micro Commercial Components Corp.** does not assume any liability arising out of the application or use of any product described herein; neither does it convey any license under its patent rights, nor the rights of others. The user of products in such applications shall assume all risks of such use and will agree to hold **Micro Commercial Components Corp.** and all the companies whose products are represented on our website, harmless against all damages.

*****LIFE SUPPORT*****

MCC's products are not authorized for use as critical components in life support devices or systems without the express written approval of Micro Commercial Components Corporation.

*****CUSTOMER AWARENESS*****

Counterfeiting of semiconductor parts is a growing problem in the industry. Micro Commercial Components (MCC) is taking strong measures to protect ourselves and our customers from the proliferation of counterfeit parts. MCC strongly encourages customers to purchase MCC parts either directly from MCC or from Authorized MCC Distributors who are listed by country on our web page cited below. Products customers buy either from MCC directly or from Authorized MCC Distributors are genuine parts, have full traceability, meet MCC's quality standards for handling and storage. **MCC will not provide any warranty coverage or other assistance for parts bought from Unauthorized Sources.** MCC is committed to combat this global problem and encourage our customers to do their part in stopping this practice by buying direct or from authorized distributors.