



NPN 2N6249 – 2N6250 – 2N6251

HIGH VOLTAGE SILICON POWER TRANSISTORS

The 2N6249 – 2N6250 – 2N6251 are NPN silicon transistors in Jedec TO-3 metal case. They are designed for high voltage inverters, switching regulators and line operated amplifier applications. Especially well suited for switching power supply applications. Compliance to RoHS.

- High Voltage Breakdown Rating
- Low Saturation Voltages
- Fast Switching Capability
- High Es/b Energy Handling Capability

ABSOLUTE MAXIMUM RATINGS

Symbol	Ratings	Value	Unit	
V_{CEO}	Collector-Emitter Voltage (*)	2N6249	200	V
		2N6250	275	
		2N6251	350	
V_{CER}	Collector-Emitter Voltage (*) $R_{BE}=50 \Omega$	2N6249	225	V
		2N6250	300	
		2N6251	375	
V_{CB}	Collector-Base Voltage (*)	2N6249	300	V
		2N6250	375	
		2N6251	450	
V_{EB}	Emitter-Base Voltage	6	V	
I_C	Collector Current	10	A	
I_{CM}	Collector Current Peak	30		
I_B	Base Current	10	A	
P_t	Total Power Dissipation @ $T_C = 25^\circ$	175	W	
T_J	Junction Temperature (*)	200	°C	
T_{stg}	Storage Temperature (*)	-65 to +200		



NPN 2N6249 – 2N6250 – 2N6251

ELECTRICAL CHARACTERISTICS

TC=25°C unless otherwise noted

Symbol	Ratings	Test Condition(s)	Min	Typ	Max	Unit	
$V_{CE(SUS)}$	Collector-Emitter Sustaining Voltage	$I_C=200\text{ mA}, I_B=0$	2N6249	200	-	-	V
			2N6250	275	-	-	
			2N6251	350	-	-	
$V_{CE(SUS)}$	Collector-Emitter Sustaining Voltage	$I_C=0.2\text{ A}, R_{BE}=50\ \Omega$	2N6249	225	-	-	V
			2N6250	300	-	-	
			2N6251	375	-	-	
I_{CEO}	Collector-Emitter Current	$V_{CE}=150\text{ V}, I_B=0$	2N6249	-	-	5	mA
		$V_{CE}=225\text{ V}, I_B=0$	2N6250				
		$V_{CE}=300\text{ V}, I_B=0$	2N6251				
I_{CEX}	Collector Cutoff Current	$V_{CE}=200\text{ V}, V_{EB}=-1.5\text{ V}$	2N6249	-	-	5	mA
		$V_{CE}=200\text{ V}, V_{EB}=-1.5\text{ V}$ $T_C=150^\circ\text{C}$		-	-	10	
		$V_{CE}=275\text{ V}, V_{EB}=-1.5\text{ V}$	2N6250	-	-	5	
		$V_{CE}=275\text{ V}, V_{EB}=-1.5\text{ V}$ $T_C=150^\circ\text{C}$		-	-	10	
		$V_{CE}=350\text{ V}, V_{EB}=-1.5\text{ V}$	2N6251	-	-	5	
		$V_{CE}=350\text{ V}, V_{EB}=-1.5\text{ V}$ $T_C=150^\circ\text{C}$		-	-	10	
I_{EBO}	Emitter Cutoff Current	$V_{BE}=6\text{ V}, I_C=0$	2N6249	-	-	1	mA
			2N6250				
			2N6251				
h_{FE}	Dc Current Gain	$I_C=10\text{ A}, V_{CE}=3\text{ V}$	2N6249	10	-	50	-
			2N6250	8	-	50	
			2N6251	6	-	50	
$V_{CE(SAT)}$	Collector-Emitter Saturation Voltage (*)	$I_C=10\text{ A}, I_B=1\text{ A}$	2N6249	-	-	1.5	V
		$I_C=10\text{ A}, I_B=1.25\text{ A}$	2N6250				
		$I_C=10\text{ A}, I_B=1.67\text{ A}$	2N6251				
$V_{BE(SAT)}$	Base-Emitter Saturation Voltage (*)	$I_C=10\text{ A}, I_B=1\text{ A}$	2N6249	-	-	2.25	V
		$I_C=10\text{ A}, I_B=1.25\text{ A}$	2N6250				
		$I_C=10\text{ A}, I_B=1.67\text{ A}$	2N6251				
$I_{s/b}$	Second Breakdown Collector Current With Base Forward Biased	$V_{CE}=30\text{ V}$ $t=1\text{ s}, \text{non-repetitive}$		5.8	-	-	A
f_T	Transition Frequency	$V_{CE}=10\text{ V}, I_C=1\text{ A}, f=1.0\text{ MHz}$		2.5	-	-	MHz



NPN 2N6249 – 2N6250 – 2N6251

SWITCHING TIMES

Symbol	Ratings	Test Condition(s)	Min	Typ	Max	Unit	
t_r	Rise Time	$V_{CC}= 200\text{ V}, I_C= 10\text{ A}$ $I_{B1} = -I_{B2}=1\text{ A}$	2N6249	-	-	2	μs
t_s	Storage Time	$V_{CC}= 200\text{ V}, I_C= 10\text{ A}$ $I_{B1} = -I_{B2}=1.25\text{ A}$	2N6250	-	-	3.5	
t_f	Fall Time	$V_{CC}= 200\text{ V}, I_C= 10\text{ A}$ $I_{B1} = -I_{B2}=1.67\text{ A}$	2N6251	-	-	1	

THERMAL CHARACTERISTICS

Symbol	Ratings	Value	Unit
R_{thJC}	Thermal Resistance, Junction to Case	1	°C/W



NPN 2N6249 – 2N6250 – 2N6251

MECHANICAL DATA CASE TO-3

DIMENSIONS (mm)		
	min	max
A	11	13.10
B	0.97	1.15
C	1.5	1.65
D	8.32	8.92
F	19	20
G	10.70	11.1
N	16.50	17.20
P	25	26
R	4	4.09
U	38.50	39.30
V	30	30.30

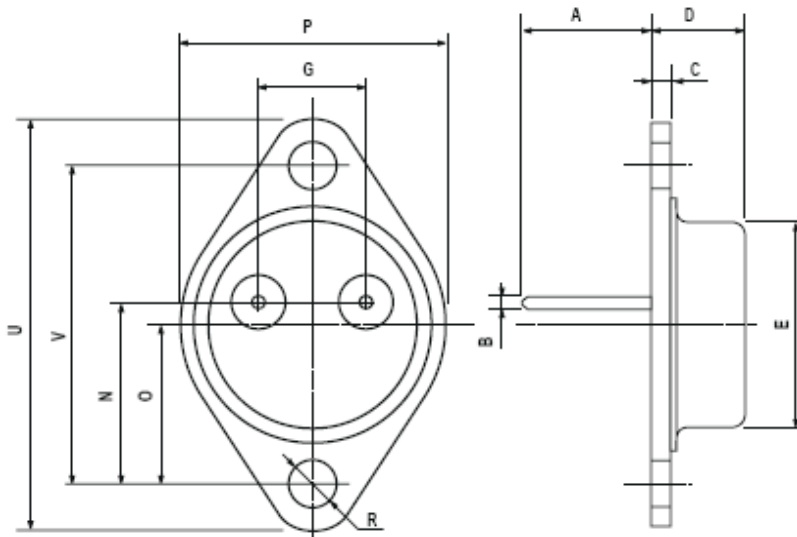

Pin 1 :	Base
Pin 2 :	Emitter
Case :	Collector

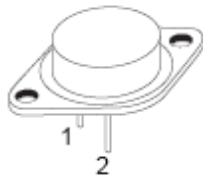

Revised October 2012

Information furnished is believed to be accurate and reliable. However, Comset Semiconductors assumes no responsibility for the consequences of use of such information nor for any infringement of patents or other rights of third parties which may results from its use. Data are subject to change without notice. Comset Semiconductors makes no warranty, representation or guarantee regarding the suitability of its products for any particular purpose, nor does Comset Semiconductors assume any liability arising out of the application or use of any product and specifically disclaims any and all liability, including without limitation consequential or incidental damages. Comset Semiconductors' products are not authorized for use as critical components in life support devices or systems.