

TO-92 Plastic-Encapsulate Transistors

TRANSISTOR(NPN)

Features

- General Purpose Switching Application

Limiting Values (Absolute Maximum Rating)

Symbol	Parameter	Value	Unit
V_{CB0}	Collector-Base Voltage	180	V
V_{CE0}	Collector-Emitter Voltage	160	V
V_{EB0}	Emitter-Base Voltage	6	V
I_C	Collector Current	0.6	A
P_C	Collector Power Dissipation	625	mW
$R_{\theta JA}$	Thermal Resistance From Junction To Ambient	200	°C/W
T_j	Junction Temperature	150	°C
T_{stg}	Storage Temperature	-55~+150	°C

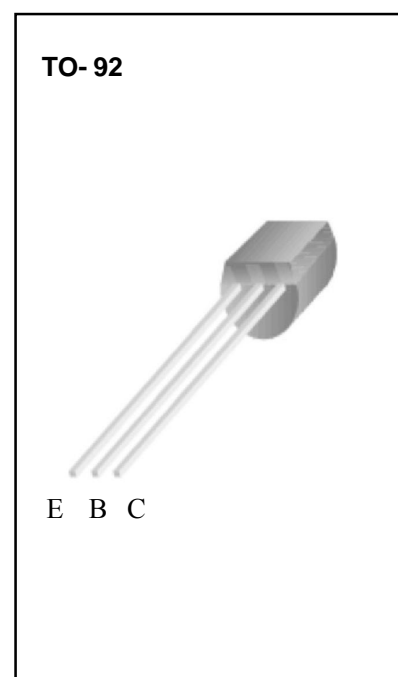

Electrical Characteristics (Ta=25°C Unless otherwise specified)

Parameter	Symbol	Test conditions	Min	Typ	Max	Unit
Collector-base breakdown voltage	$V_{(BR)CBO}$	$I_C=100\mu A, I_E=0$	180			V
Collector-emitter breakdown voltage	$V_{(BR)CEO}$ *	$I_C=1mA, I_B=0$	160			V
Emitter-base breakdown voltage	$V_{(BR)EBO}$	$I_E=10\mu A, I_C=0$	6			V
Collector cut-off current	I_{CBO}	$V_{CB}=120V, I_E=0$			50	nA
Emitter cut-off current	I_{EBO}	$V_{EB}=4V, I_C=0$			50	nA
DC current gain	$h_{FE(1)}$	$V_{CE}=5V, I_C=1mA$	80			
	$h_{FE(2)}$	$V_{CE}=5V, I_C=10mA$	80		300	
	$h_{FE(3)}$	$V_{CE}=5V, I_C=50mA$	50			
Collector-emitter saturation voltage	$V_{CE(sat) (1)}$	$I_C=10mA, I_B=1mA$			0.15	V
	$V_{CE(sat) (2)}$	$I_C=50mA, I_B=5mA$			0.2	V
Base-emitter saturation voltage	$V_{BE(sat) (1)}$	$I_C=10mA, I_B=1mA$			1	V
	$V_{BE(sat) (2)}$	$I_C=50mA, I_B=5mA$			1	V
Collector output capacitance	C_{ob}	$V_{CB}=10V, I_E=0, f=1MHz$			6	pF
Emitter input capacitance	C_{ib}	$V_{BE}=0.5V, I_C=0, f=1MHz$			20	pF
Transition frequency	f_T	$V_{CE}=10V, I_C=10mA, f=100MHz$	100		300	MHz

*Pulse test: pulse width $\leq 300\mu s$, duty cycle $\leq 2.0\%$.

CLASSIFICATION OF h_{FE}

RANK	A	B	C
RANGE	80-100	100-150	150-200

Typical Characteristics

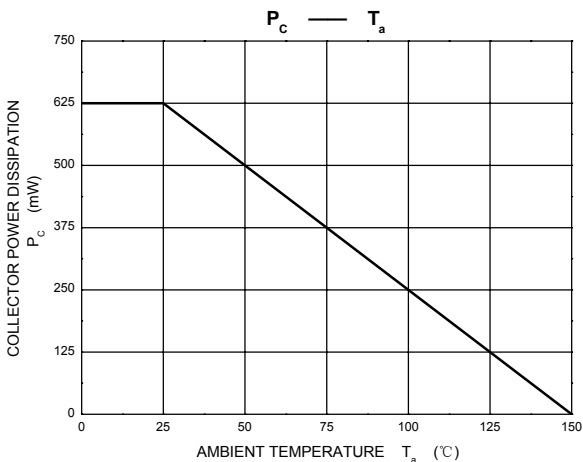
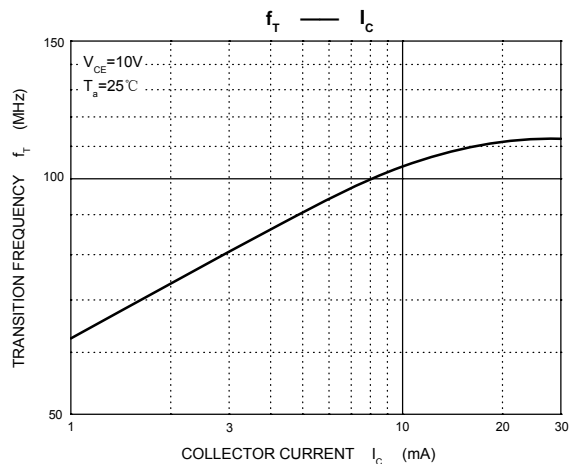
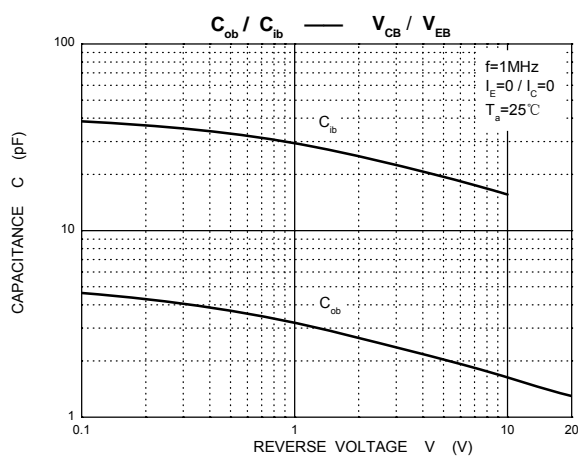
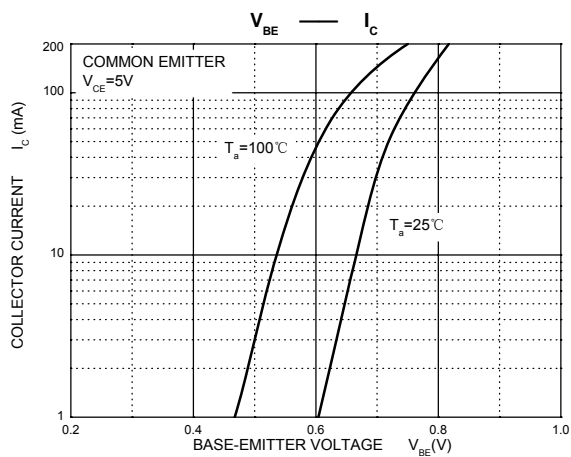
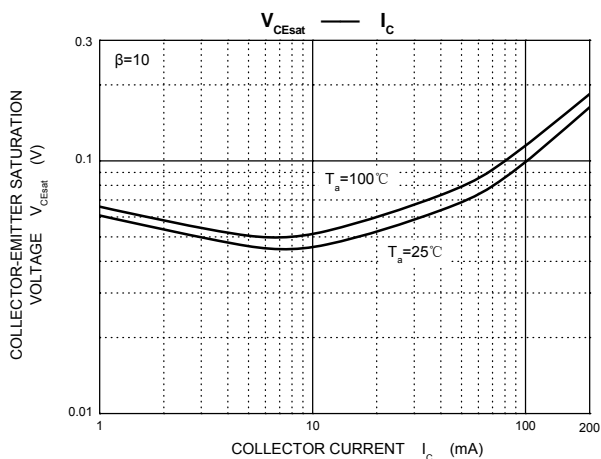
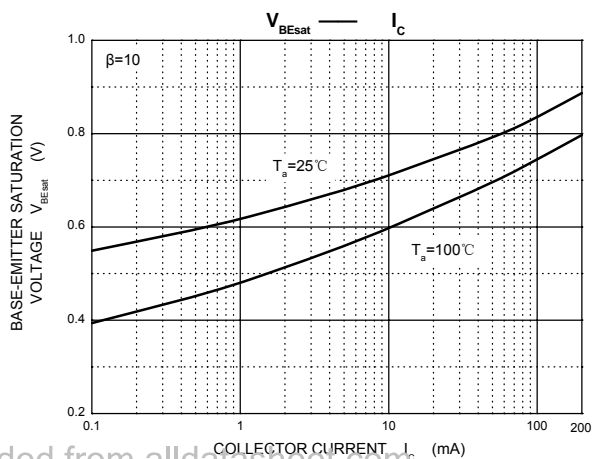
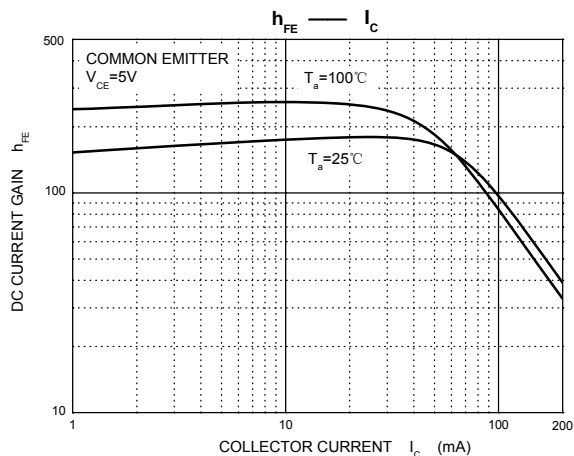
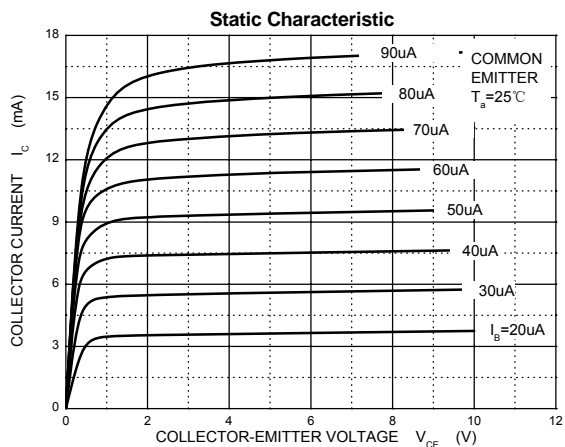

TO-92 Package Outline Dimensions

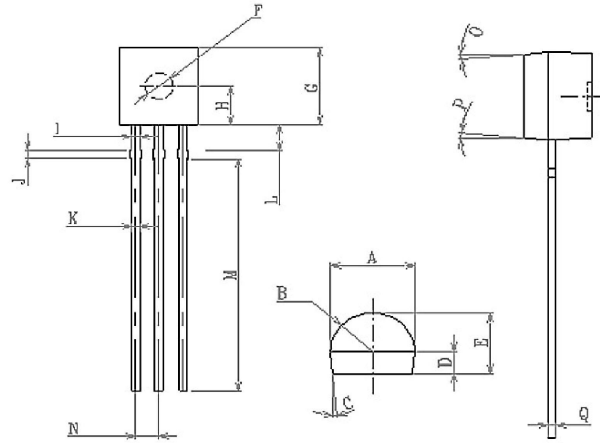

SYMBOL	MIN	MAX	SYMBOL	MIN	MAX
A	4.1	4.3	K	0.36	0.56
B	R2.0	R2.2	L	1.35	1.45
C	4.1		M	12.00	12.5
D	1.1	1.2	N	1.24	1.3
E	3.13	3.33	O	5°	
F	Φ1.48	Φ1.52	P	5°	
G	4.4	4.6	Q	0.37	0.39
H	2.2	2.3			
I	0.36	0.56			
J	0.5	0.6			

单位: mm

Downloaded from alldatasheet.com

TO-92 Suggested Pad Layout

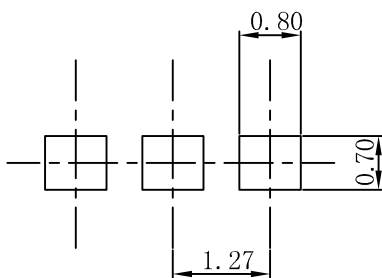

Note:

1. Controlling dimension: in millimeters.
2. General tolerance: ± 0.05 mm.
3. The pad layout is for reference purposes only.

NOTICE

JSHD reserve the right to make modifications, enhancements, improvements, corrections or other changes without further notice to any product herein. JSHD does not assume any liability arising out of the application or use of any product described herein.

TO-92 Tape and Reel

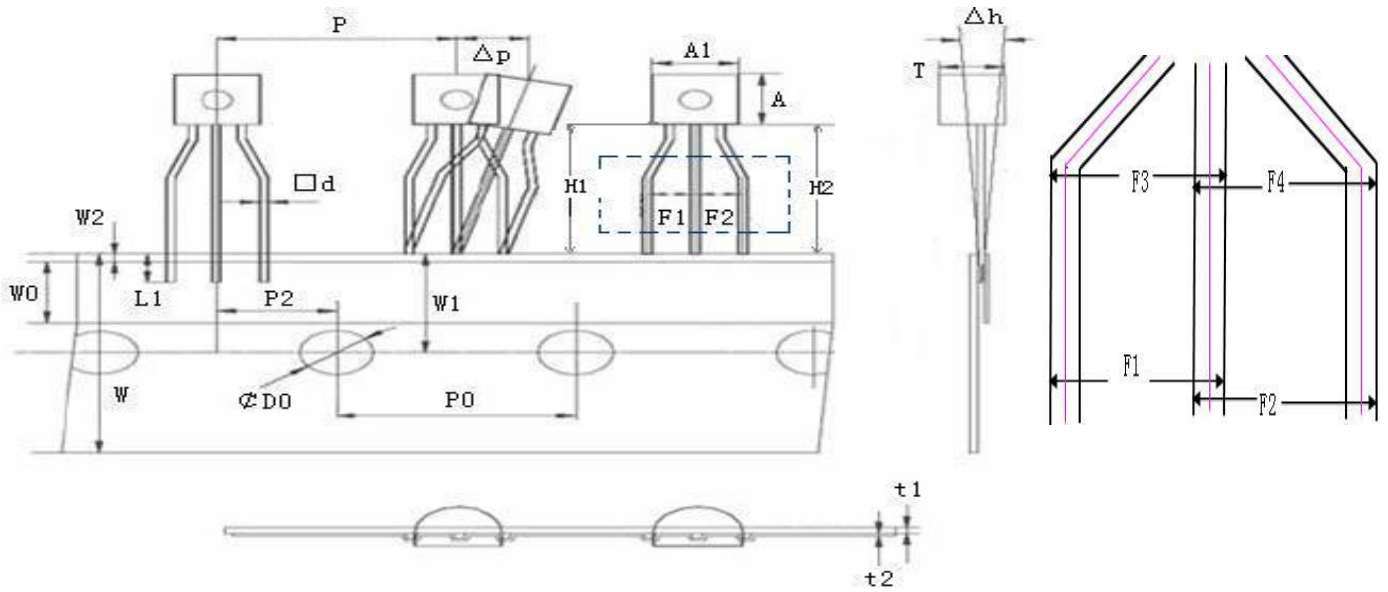

Symbol	mm			Inches		
	Min	Nom	Max	Min	Nom	Max
A1	4.1	4.2	4.3	0.171	0.176	0.180
A	4.4	4.5	4.6	0.184	0.188	0.192
F	3.13	3.23	3.33	0.131	0.134	0.139
□d	0.36	0.45	0.56	0.015	0.018	0.022
L1	2.5	—	—	0.098	—	—
P	12.4	—	13	0.488	—	0.512
P0	12.5	12.7	12.9	0.492	0.5	0.508
P2	6.05	6.35	6.65	0.238	0.25	0.262
F1,F2	2.75	3.00	3.25			
F3,F4	2.75	3.00	3.25			
F1-F2	—	—	0.4			

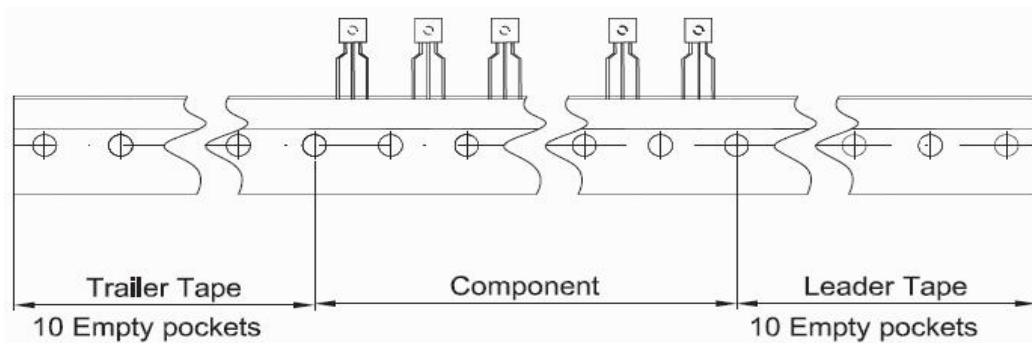

Package	Box	Box Size(mm)	Carton	Carton Size(mm)
TO-92	2000PCS	343×158×42	20000PCS	470×358×180