

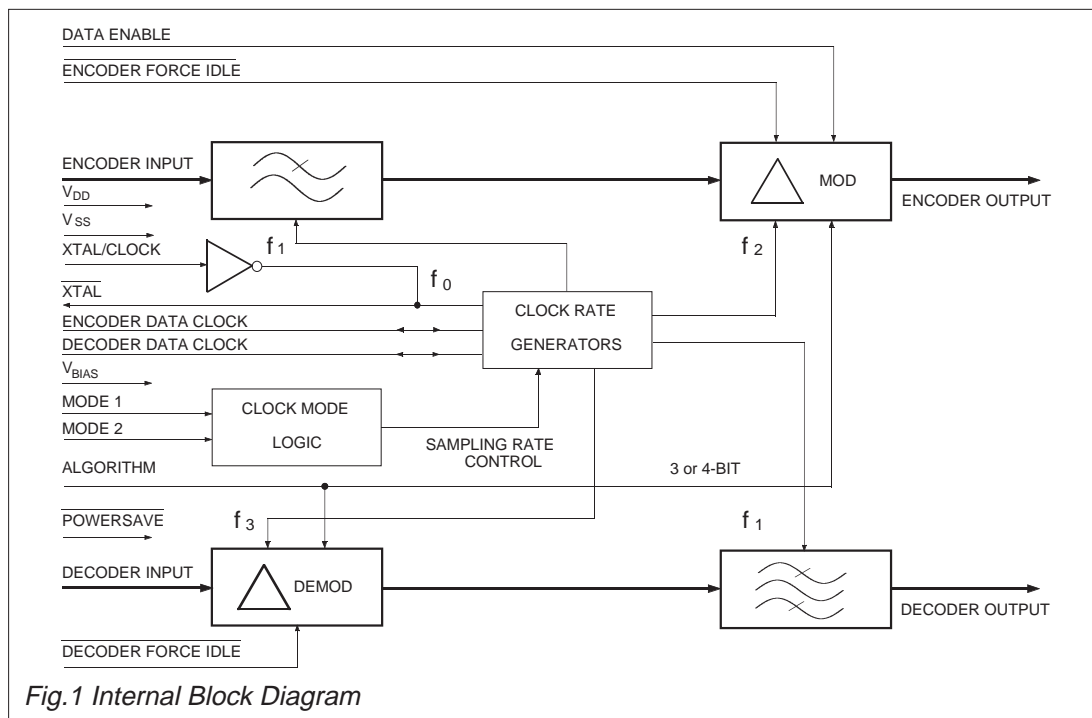

Features/Applications

- Designed to Meet Eurocom D1-IA8
- Meets Stanag 4209 and Stanag 4380
- Military Communications
- Delta MUX, Switch and Phone Applications
- Single Chip Full Duplex Codec
- On-Chip Input and Output Filters
- Programmable Sampling Clocks
- 3 or 4-bit Compand Algorithm
- Forced Idle Facility
- Powersave Facility
- Single 5V CMOS Process
- Full Duplex CVSD* Codec



FX619

Brief Description

The FX619 is an LSI circuit designed as a *Continuously Variable Slope Delta Codec and is intended for use in military communications systems.

Designed to meet Eurocom D1-IA8 with external components, the device is suitable for applications in military Delta Multiplexers, switches and phones.

Encoder input and decoder output filters are incorporated on-chip. Sampling clock rates can be programmed to 16, 32 or 64 k bits/second from an internal clock generator or may be externally applied in the range 8 to 64 k bits/second. Sampling clock frequencies are output for the synchronization of external circuits.

The encoder has an enable function for use in multiplexer applications. Encoder and Decoder forced idle facilities are provided forcing a 10101010..... pattern in encode and a $V_{DD}/2$ bias in decode. The companding circuits may be operated with a 3 or 4-bit algorithm which is externally selected. The device may be put in the standby mode by selection of the powersave facility. A reference 1.024MHz oscillator uses an external clock or Xtal. The FX619 is a low-power, 5 volt CMOS device and is available in 22-pin cerdip DIL, 24-lead/pin plastic and 28-lead ceramic leadless SMT packages.

Pin Number Function

FX619 J	FX619 L1/L2	FX619 M1													
1	1	1	Xtal/Clock : Input to the clock oscillator inverter. A 1.024MHz Xtal input or externally derived clock is injected here. See Clock Mode pins and Figure 3.												
	2	2	No connection												
2	3	3	Xtal : Output of clock oscillator inverter. Xtal circuitry shown is in accordance with CML application note D/XT/1 April 1986.												
3	4	4	No connection												
4	5	5	Encoder Data Clock : A logic I/O port. External encode clock input or internal data clock output. Clock frequency is dependant upon clock mode 1, 2 inputs and Xtal frequency (see Clock Mode pins).												
5	6	6	<p>Encoder Output : The encoder digital output, this is a three state output whose condition is set by Data Enable and Powersave inputs as shown :</p> <table border="1" style="margin-left: auto; margin-right: auto;"> <thead> <tr> <th>Data Enable</th> <th>Powersave</th> <th>Encoder Output</th> </tr> </thead> <tbody> <tr> <td>1</td> <td>1</td> <td>Enabled</td> </tr> <tr> <td>0</td> <td>1</td> <td>High Z (o/c)</td> </tr> <tr> <td>1</td> <td>0</td> <td>Vss</td> </tr> </tbody> </table>	Data Enable	Powersave	Encoder Output	1	1	Enabled	0	1	High Z (o/c)	1	0	Vss
Data Enable	Powersave	Encoder Output													
1	1	Enabled													
0	1	High Z (o/c)													
1	0	Vss													
		7, 8	No connection												
6	7	9	Encoder Force Idle : When this pin is a logical '0' the encoder is forced to an idle state and the encoder digital output is 0101..., a perfect idle pattern. When this pin is a logical '1' the encoder encodes as normal. Internal 1MΩ Pullup.												
7	8	10	Data Enable : Data is made available at the encoder output pin by control of this input. See Encoder Output pin. Internal 1MΩ Pullup.												
8	9	11	No connection												
9	10	12	Bias : Normally at $V_{DD}/2$ bias, this pin requires to be externally decoupled by a capacitor, C_4 . Internally pulled to V_{SS} when "Powersave" is a logical '0'.												
10	11	13	Encoder Input : The analogue signal input. Internally biased at $V_{DD}/2$, external components are required on this input. The source impedance should be less than 100Ω, output idle channel noise levels will improve with an even lower source impedance. See Fig. 3.												
11	12	14	V_{SS} : Negative Supply.												

Pin Number Function

FX619 J	FX619 L1/L2	FX619 M1																
12	13	15,16	No connection															
13	14	17	Decoder Output : The recovered analogue signal is output at this pin, it is the buffered output of a bandpass filter and requires external components. During "Powersave" this output is o/c.															
14	15	18,19	No connection															
15	16	20	Powersave : A logical '0' at this pin puts most parts of the codec into a quiescent non-operational state. When at a logical '1' the codec operates normally. Internal 1M Ω Pullup.															
	17	21	No connection															
16	18	22	Decoder Force Idle : A logical '0' at this pin gates a 0101...pattern internally to the decoder so that the decoder output goes to $V_{DD}/2$. When this pin is at a logical '1' the decoder operates as normal. Internal 1M Ω Pullup.															
17	19	23	Decoder Input : The received digital signal input. Internal 1M Ω Pullup.															
18	20	24	Decoder Data Clock : A Logic I/O port. External decode clock input or internal data clock output, dependant upon clock mode 1, 2 inputs, see Clock Mode pins.															
19	21	25	Algorithm : A logical '1' at this pin sets this device for a 3-bit companding algorithm. A logical '0' sets a 4-bit companding algorithm. Internal 1M Ω Pullup.															
20	22	26	<table border="1"> <thead> <tr> <th>Clock Mode 1</th> <th>Clock Mode 2</th> <th>Facility</th> </tr> </thead> <tbody> <tr> <td>0</td> <td>0</td> <td>External clocks</td> </tr> <tr> <td>0</td> <td>1</td> <td>Internal, 64kb/s = $f \div 16$</td> </tr> <tr> <td>1</td> <td>0</td> <td>Internal, 32kb/s = $f \div 32$</td> </tr> <tr> <td>1</td> <td>1</td> <td>Internal, 16kb/s = $f \div 64$</td> </tr> </tbody> </table>	Clock Mode 1	Clock Mode 2	Facility	0	0	External clocks	0	1	Internal, 64kb/s = $f \div 16$	1	0	Internal, 32kb/s = $f \div 32$	1	1	Internal, 16kb/s = $f \div 64$
Clock Mode 1	Clock Mode 2	Facility																
0	0	External clocks																
0	1	Internal, 64kb/s = $f \div 16$																
1	0	Internal, 32kb/s = $f \div 32$																
1	1	Internal, 16kb/s = $f \div 64$																
21	23	27	Clock Mode 1 : Internal 1M Ω Pullups.															
22	24	28	V_{DD} : Positive Supply. A single + 5 volt power supply is required.															

Codec Integration

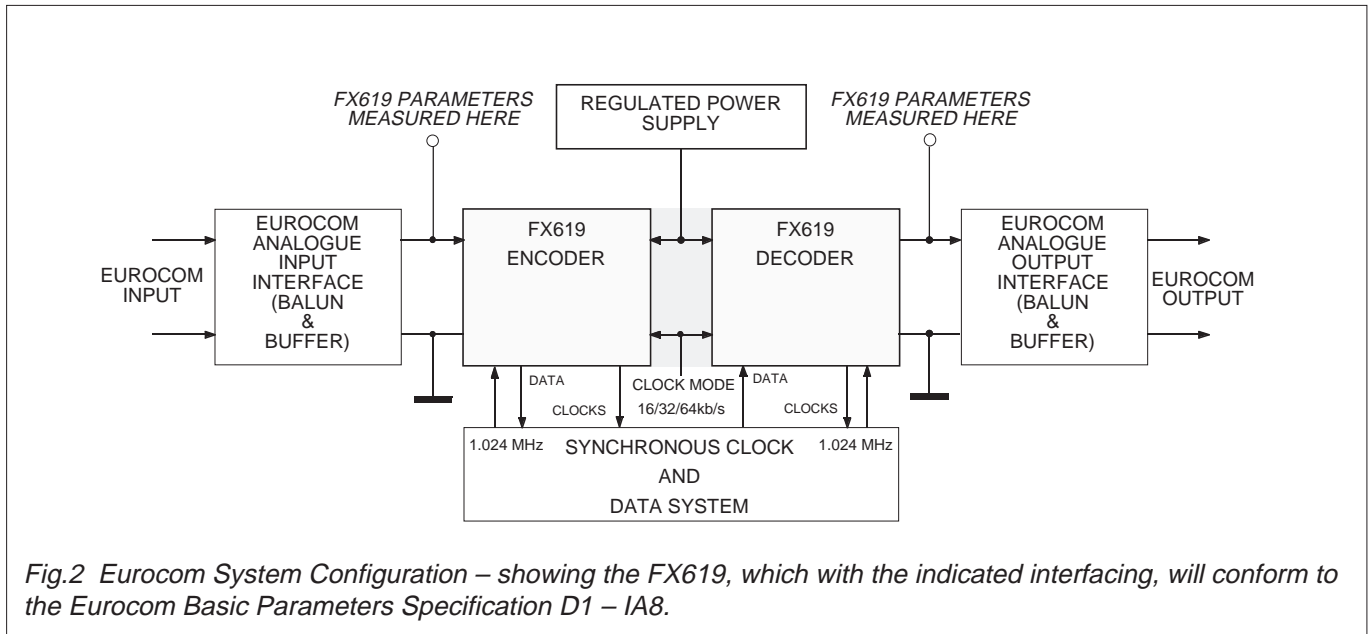

Fig.2 Eurocom System Configuration – showing the FX619, which with the indicated interfacing, will conform to the Eurocom Basic Parameters Specification D1 – IA8.

Component	Unit Value	Note – with reference to Figure 3 (below)
R ₁	1M	Oscillator Inverter bias resistor.
R ₂	Selectable	Xtal Drive limiting resistor.
C ₁	33p	Xtal Circuit drain capacitor.
C ₂	33p	Xtal Circuit gate capacitor.
C ₃	1.0μ	Encoder Input coupling capacitor – The drive source impedance to this input should be less than 100Ω. Output Idle channel noise levels will improve with an even lower source impedance.
C ₄	1.0μ	Bias decoupling capacitor.
C ₅	1.0μ	V _{DD} decoupling capacitor.
X ₁	1.024 MHz	A 1.024 MHz Xtal/clock input will yield exactly 16/32/64 kb/s data clock rates. Xtal circuitry shown is in accordance with CML application note D/XT/1 April 1986.

Tolerance :- Resistors ± 10% Capacitors ± 20%

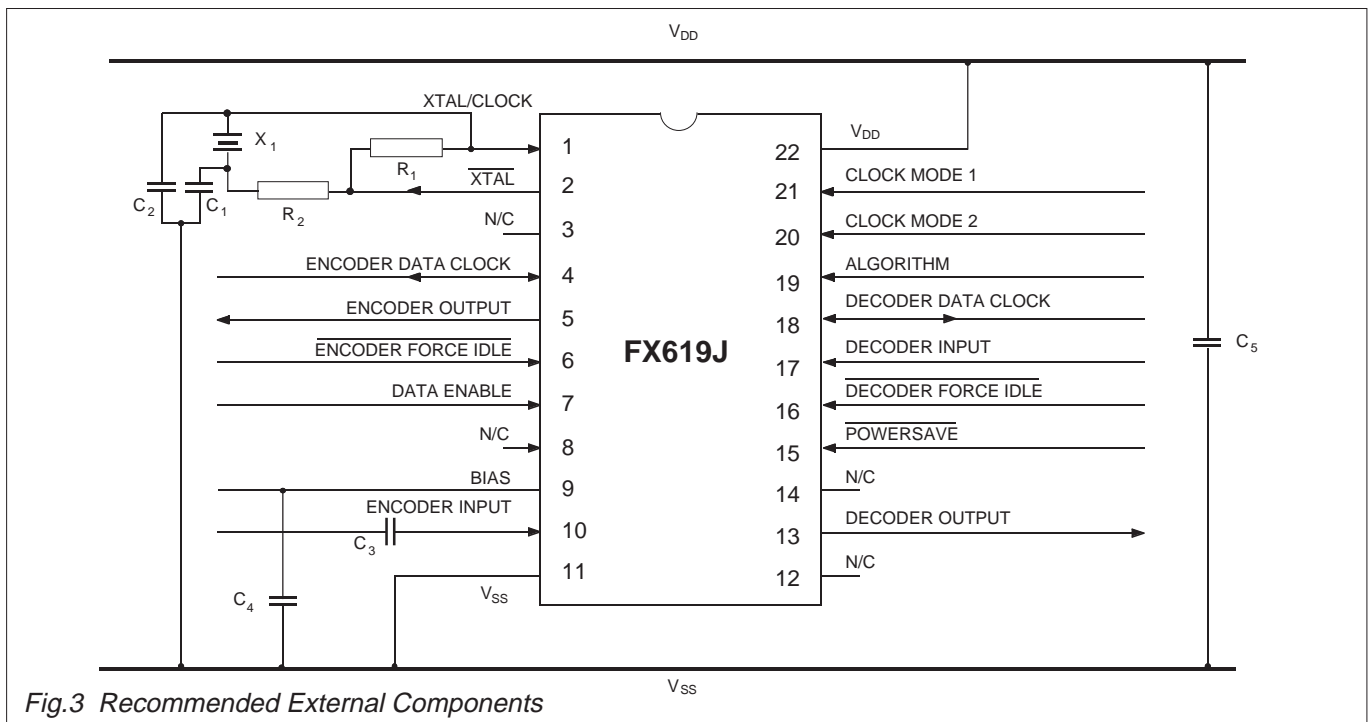

Fig.3 Recommended External Components

Codec Timing Information

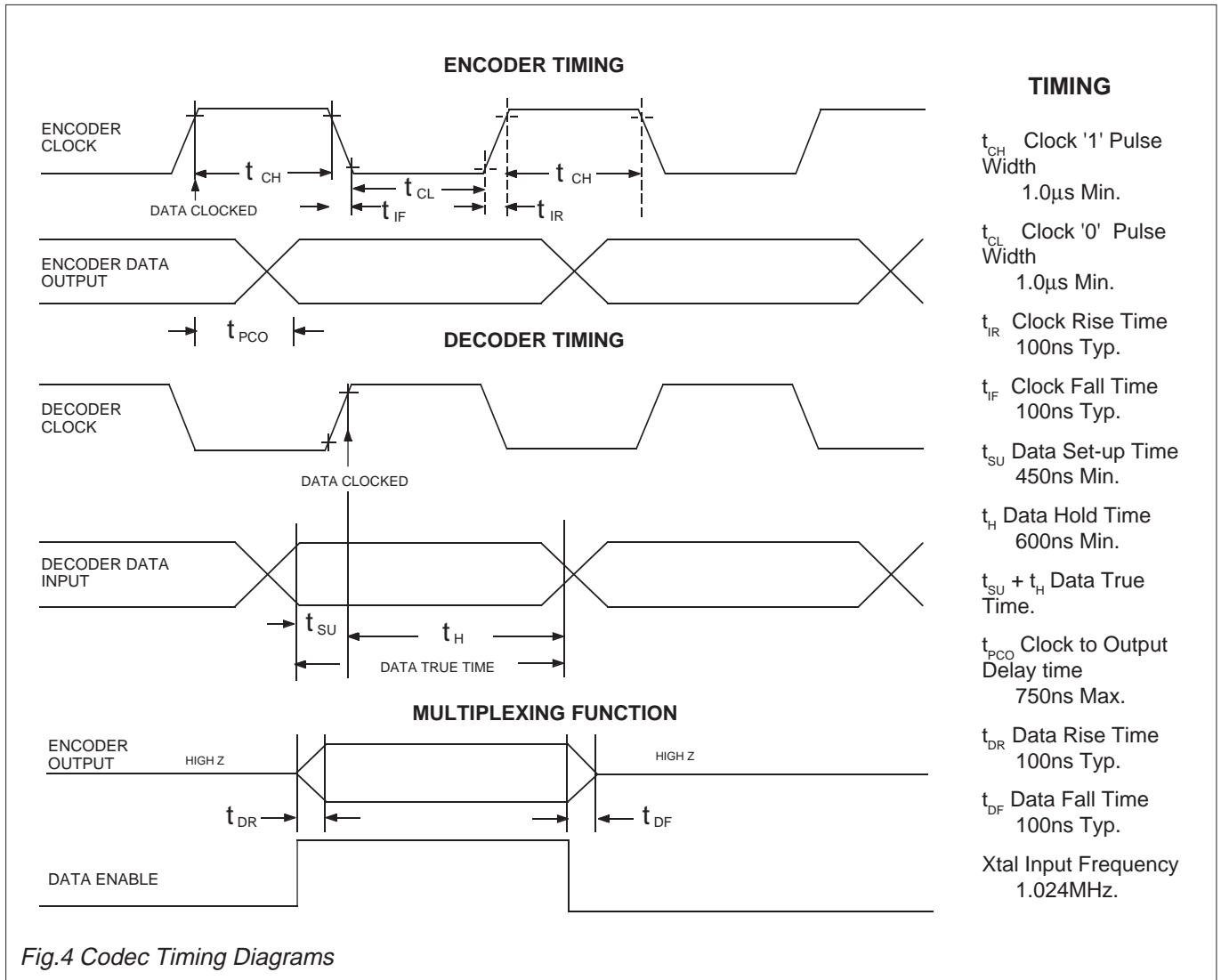

Fig.4 Codec Timing Diagrams

Codec Performance Using the Bit Sequence Tests (a to g) at the Decoder Input pin in accordance with the Eurocom Specification D1 – IA8, the decoder output is as shown in Table 1.

Test	Sample Rate	Bit Sequence at Decoder Input	MLA Duty cycle	Typical Output Level
a.	16kbit/s	10110100100100101101	0	- 41.5dBm0
	32kbit/s	1011011010101001001001001010101101101	0	- 42.0dBm0
b.	16kbit/s	11011001001001001101	0.05	- 25.0dBm0
	32kbits	1011011010101001001000100100101011011011	0.05	- 25.0dBm0
c.	16kbits	10110101000100101011	0.1	- 19.0dBm0
	32kbit/s	11011011101010010001000100100101011011101	0.1	- 18.5dBm0
d.	16kbit/s	11011001000010011011	0.2	- 11.0dBm0
	32kbit/s	1101110110010100010000100010011010111011	0.2	- 11.5dBm0
e.	16kbit/s	11011010000010010111	0.3	- 6.5dBm0
	32kbit/s	1110111011001000100000010001001101110111	0.3	- 6.5dBm0
f.	16kbit/s	11011010000001001111	0.4	- 3.0dBm0
	32kbit/s	1111011101010001000000001000101011101111	0.4	- 3.0dBm0
g.	16kbit/s	11101010000000101111	0.5	0dBm0
	32kbit/s	1111101110100010000000000100010111011111	0.5	0dBm0

Table 1 Bit Sequence Test Table

Codec Performance relative to the Eurocom Specification D1 - IA8

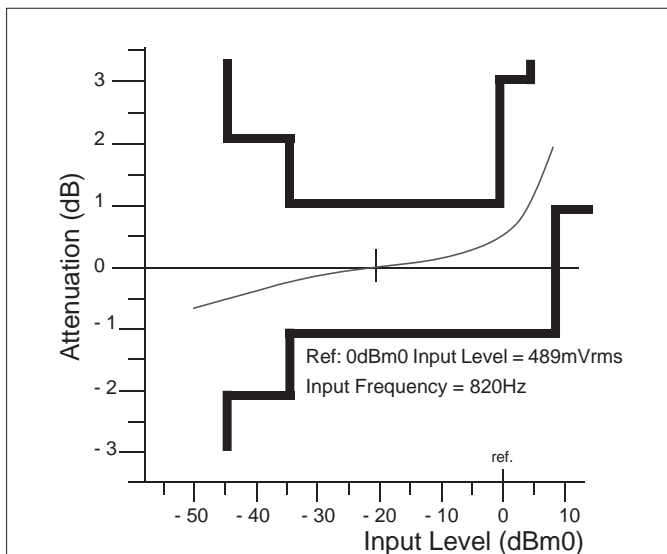

Fig.5 Gain vs Input Level (16kbit/s)

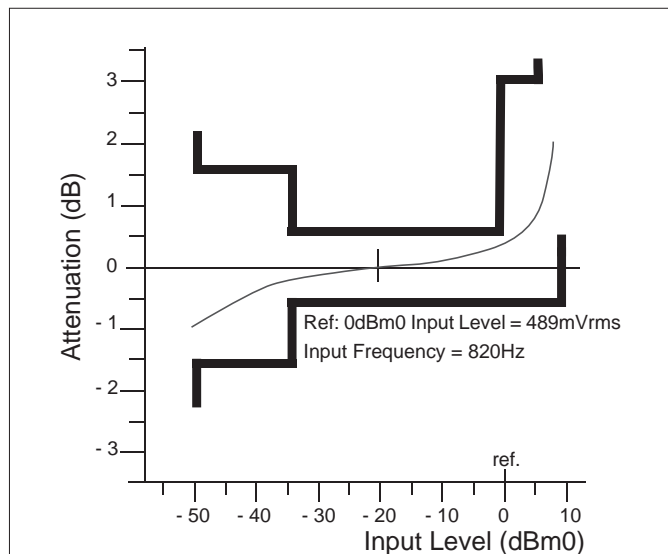

Fig.6 Gain vs Input Level (32kbit/s)

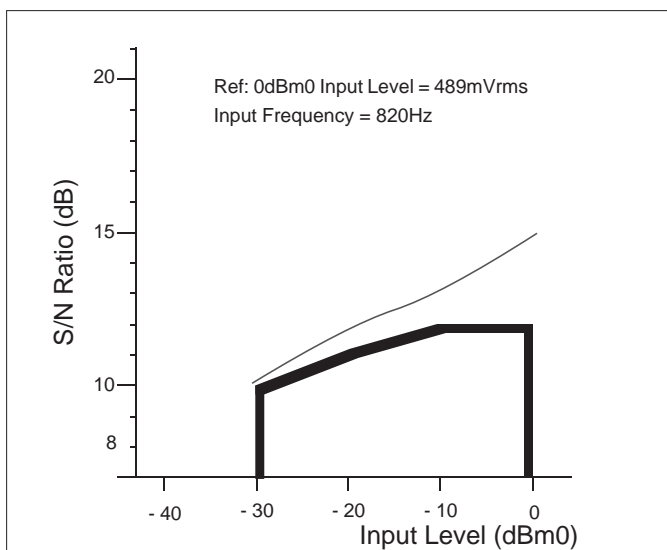

Fig.7 S/N vs Input Level (16kbit/s)

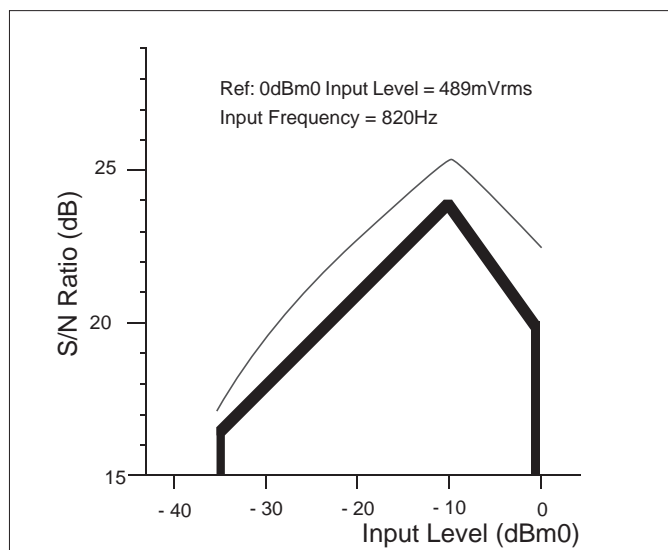

Fig.8 S/N vs Input Level (32kbit/s)

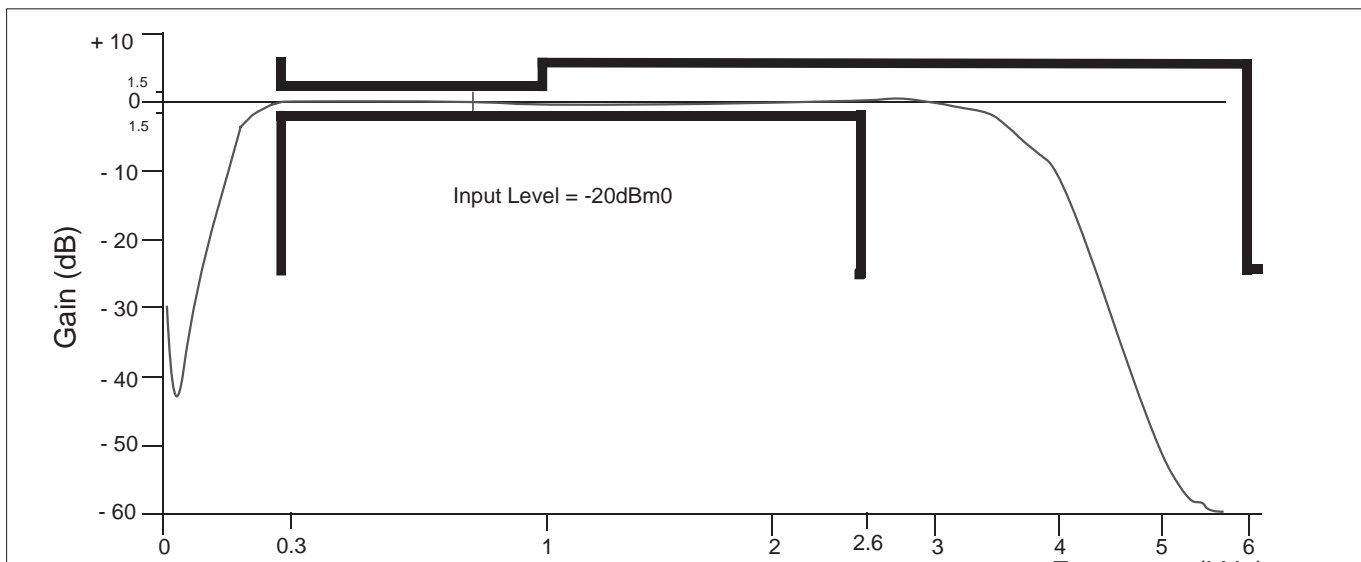
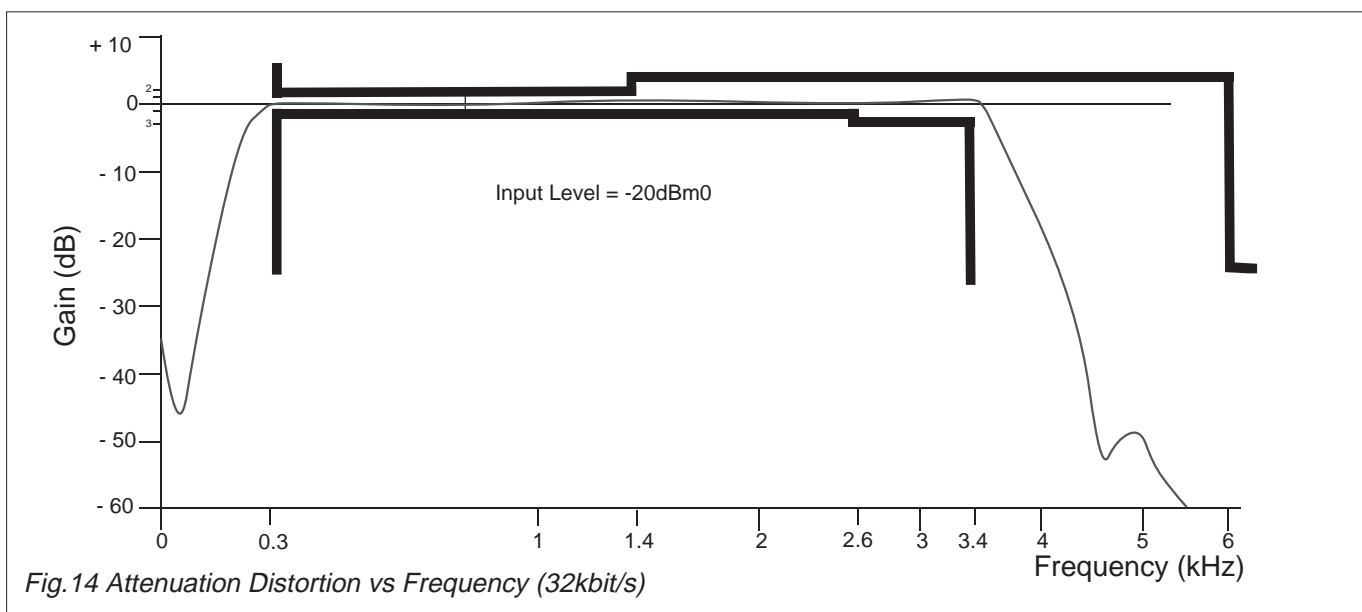
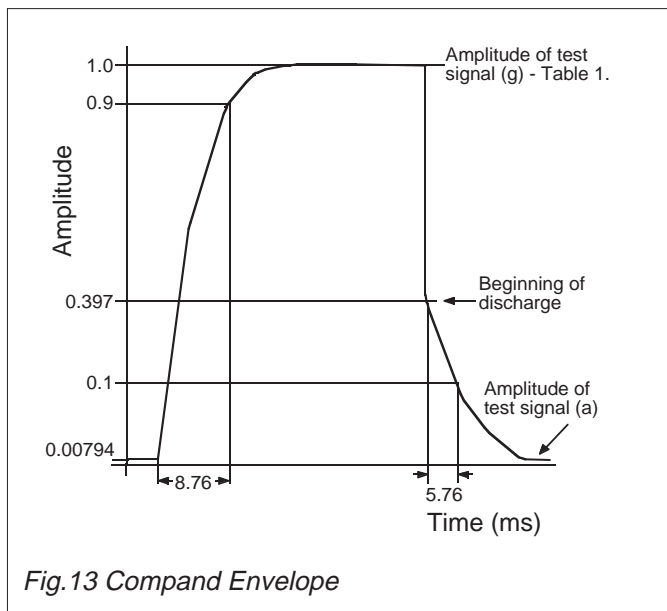
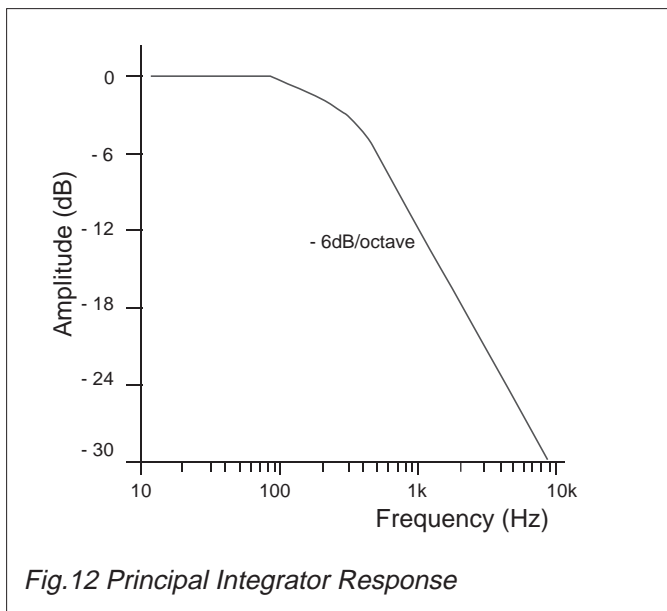
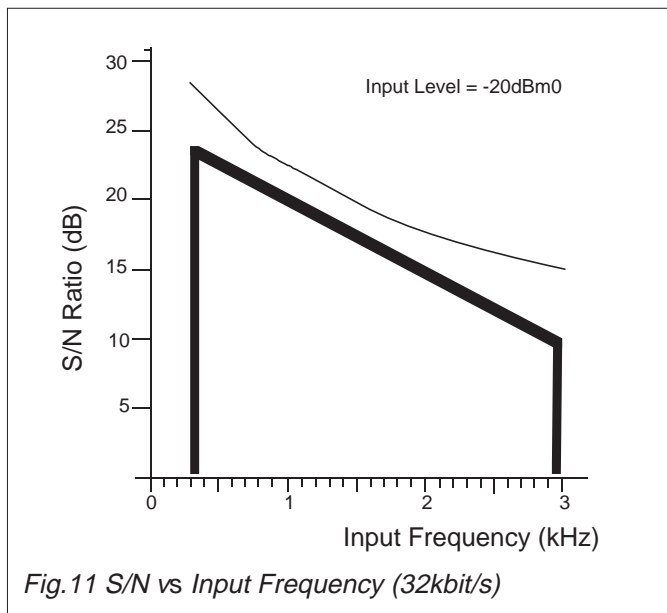
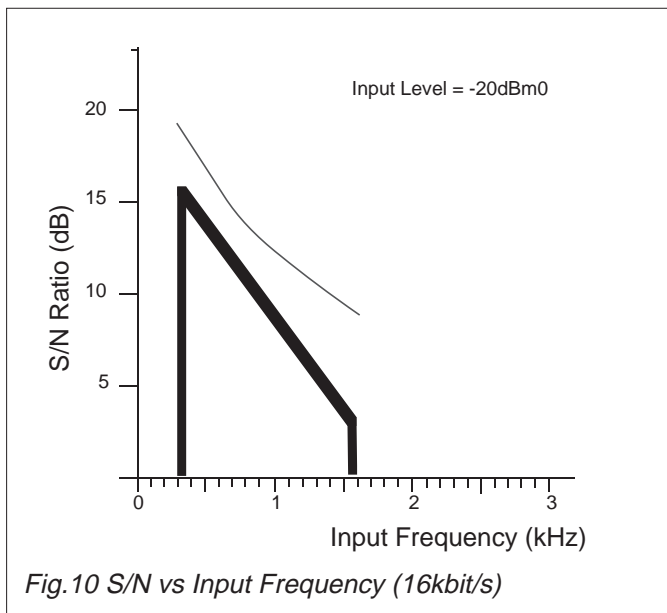

Fig.9 Attenuation Distortion vs Frequency (16kbit/s)

Codec Performance relative to the Eurocom Specification D1 - IA8



Specifications

Absolute Maximum Ratings

Exceeding the maximum rating can result in device damage. Operation of the device outside the operating limits is not implied.

Supply voltage	-0.3 to 7.0V
Input voltage at any pin (ref $V_{SS} = 0V$)	-0.3 to ($V_{DD} + 0.3V$)
Source/sink current (supply pins)	$\pm 30mA$
(other pins)	$\pm 20mA$
Total device dissipation @ 25°C	800mW Max.
Derating (J and M1 packages)	10mW/°C
Derating (L1 and L2 packages)	13mW/°C
Operating temperature range:	FX619J -40°C to +85°C (cerdip)
	FX619L1/L2 -40°C to +85°C (plastic)
	FX619M1 -40°C to +85°C (cerquad)
Storage temperature range:	FX619J -55°C to +125°C (cerdip)
	FX619L1/L2 -40°C to +85°C (plastic)
	FX619M1 -55°C to +125°C (cerquad)

Operating Limits

All characteristics are measured using the following parameters unless otherwise specified:

$V_{DD} = 5.0V$, $T_{AMB} = 25^\circ C$, Xtal/Clock $f_0 = 1.024MHz$, Audio Level 0dB ref (0dBm0) = 489 mV rms.

Audio Test Frequency = 820 Hz. Sample Clock Rate = 32kb/s. Compand Algorithm = 3-bit.

Characteristics	See Note	Min.	Typ.	Max.	Unit
Static Values					
Supply Voltage	1	4.5	5.0	5.5	V
Supply Current (Enabled)		–	4.5	–	mA
Supply Current (Powersave)		–	1.0	–	mA
Inputs Logic '1'	8	3.5	–	–	V
Inputs Logic '0'	8	–	–	1.5	V
Outputs Logic '1'	8	4.0	–	–	V
Outputs Logic '0'	8	–	–	1.0	V
Digital Input Impedance (Logic I/O pins)		1.0	10	–	MΩ
Digital Input Impedance (Logic input pins, pullup resistor)	2	300	–	–	kΩ
Digital Output Impedance		–	–	4	kΩ
Analogue Input Impedance	4	–	1	–	kΩ
Analogue Output Impedance	7	–	–	800	Ω
Three State Output Leakage Current (output disabled)		-4	–	+4	μA
Insertion Loss	3	-2	–	+2	dB
Dynamic Values					
Encoder:					
Analogue Signal Input Levels	5,9	-35	–	+6	dBm0
Principle Integrator Frequency		–	275	–	Hz
Encoder Passband		–	3400	–	Hz
Compand Time Constant		–	4	–	ms
Decoder:					
Analogue Signal Output Levels	5,9	-35	–	+6	dBm0
Decoder Passband		300	–	3400	Hz
Encoder Decoder (Full codec):					
Compression Ratio ($C_d = 0.5$ to $C_d = 0.0$)		–	50	–	
Passband		300	–	3400	Hz
Stopband		6	–	10	kHz
Stopband Attenuation		–	60	–	dB
Passband Gain		–	0	–	dB
Passband Ripple (300Hz – 1400Hz)		-1	–	+1	dB
(1400Hz – 2600Hz)		-1	–	+3	dB
(2600Hz – 3400Hz)		-2	–	+3	dB
Output Noise (Input short circuit)	9	–	–	-62	dBm0p
Perfect Idle Channel Noise (Encoder forced)	9	–	-63	–	dBm0p
Group Delay Distortion	6				
(1000Hz to 2600Hz)		–	–	450	μs
(600Hz to 2800Hz)		–	–	750	μs
(500Hz to 3000Hz)		–	–	1.5	ms
Xtal/Clock Frequency		500	1024	1500	kHz

– Notes to be used with these specifications are detailed on page 9 (overleaf)

>>>

Specifications

- Notes:**
1. Dynamic characteristics are specified at 5V unless otherwise specified.
 2. All logic inputs except, Encoder and Decoder Data Clocks.
 3. For an Encoder/Decoder combination, Insertion Loss contributed by a single component is half this figure.
 4. Driven with a source impedance of $<100\Omega$.
 5. Recommended values – See Figures 5, 6, 7 and 8.
 6. Group Delay Distortion for the full codec is relative to the delay with 820Hz, -20dB at the encoder input.
 7. An Emitter Follower output stage.
 8. $4V = 80\% V_{DD}$, $3.5V = 70\% V_{DD}$, $1.5V = 30\% V_{DD}$, $1V = 20\% V_{DD}$.
 9. Analogue Voltage Levels used in this Data Sheet: $0dBm0 = 489mV_{rms} = -4dBm = 0dB$.
 $-20dBm0 = 49mV_{rms} = -24dBm$.

Process Information

The following Table gives details of the process and test controls employed in the manufacture of the FX619 Eurocom Delta Codec in J and M1 packages only. L1 and L2 products are supplied without the process and test controls detailed below.

Function	Reference	Remarks
Hermeticity		
Fine Leak Test –	Mil Std 883C	using Method 1014 – test condition A1.
Coarse Leak Test –	Mil Std 883C	using Method 1014 – test condition C.
Burnin	Mil Std 883C	using Method 1015 – test condition E. 168 Hours @ 85°C with 5v power, and clocks applied.
Temperature Cycling	Mil Std 883C	using Method 1010 – test condition B. 10 cycles -55°C to +125°C.

The following mechanical assembly tests are Qualified to BS9450

Vibration	BS9450	Section 1.2.6.8.1 55Hz to 500Hz at 98 m/sec acceleration.
Shock	BS9450	Section 1.2.6.6 981 m/sec for 6 msec.
Low Pressure Transport and Storage – Operation –	BS9450	Section 1.2.6.12 225mmHg (altitude 9000m). 600mmHg (altitude 2400m).
Humidity	BS9450	Section 1.2.6.4 96 Hours @ 45°C, 95% relative humidity plus condensed water.

Application Recommendations

Due to the very low levels of signal and idle channel noise specified in the Eurocom Basic Parameters Specification D1 – IA8 – a noisy or badly regulated power supply could cause instability putting the overall system performance out of specification. Adherence to the points noted below will assist in minimizing this problem.

- | | |
|---|--|
| (a) Care should be taken on the design and layout of the printed circuit board. | (e) Inputs and outputs should be screened wherever possible. |
| (b) All external components (as recommended in Figure 3) should be kept close to the package. | (f) A "ground plane" connected to V_{SS} will assist in eliminating external pick-up on the input and output pins. |
| (c) Tracks should be kept short, particularly the Encoder Input capacitor and the V_{BIAS} capacitor. | (g) It is recommended that the power supply rails have less than 1mVrms of noise allowed. |
| (d) Xtal/clock tracks should be kept well away from analogue inputs and outputs. | (h) The source impedance to the Encoder Input pin must be less than 100Ω , Output Idle channel noise levels will improve with even lower source impedances. |

Package Outlines

The FX619 is available in the package styles outlined below. Mechanical package diagrams and specifications are detailed in Section 10 of this document. Pin 1 identification marking is shown on the relevant diagram and pins on all package styles number anti-clockwise when viewed from the top.

FX619J 22-pin cerdip DIL (J3)

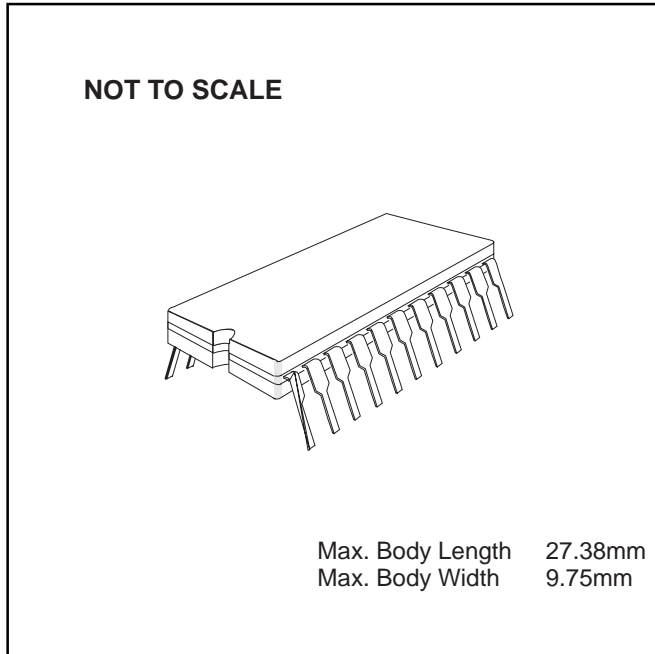

Handling Precautions

The FX619 is a CMOS LSI circuit which includes input protection. However precautions should be taken to prevent static discharges which may cause damage.

FX619L1 24-pin quad plastic encapsulated bent and cropped (LG)

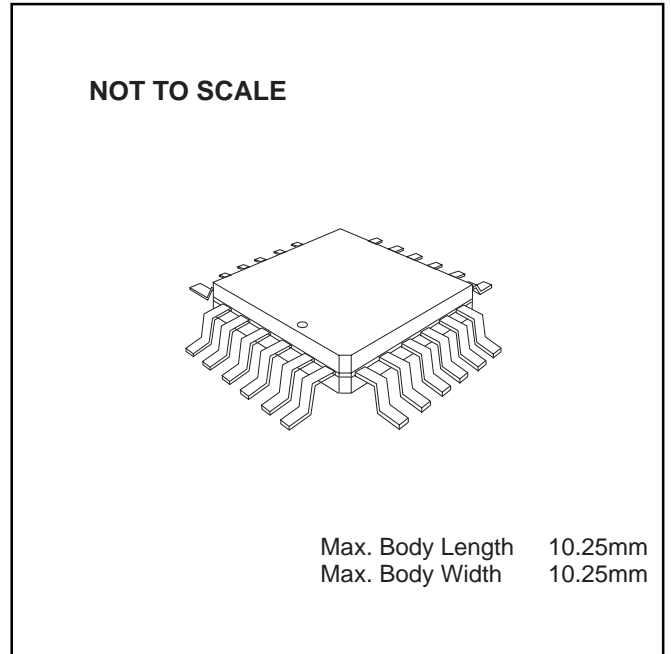

FX619L2 24-pin plastic leaded chip carrier (LS)

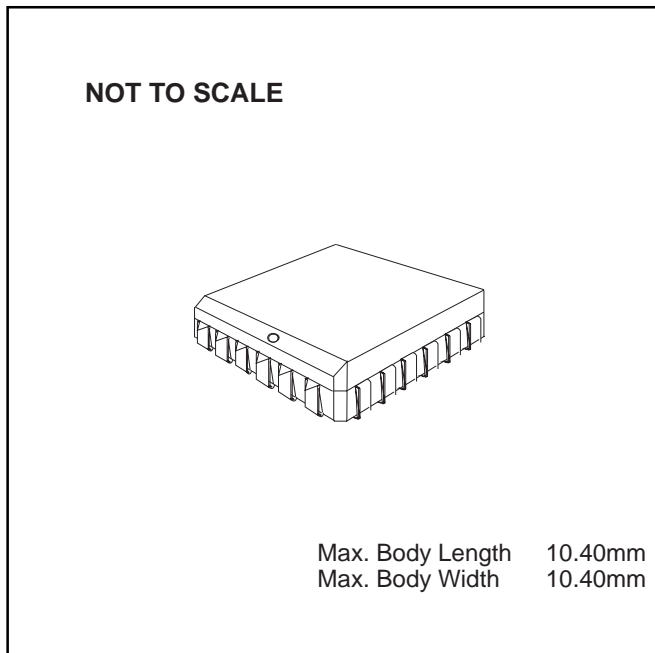

FX619M1 28-lead ceramic leaded chip carrier (M1)

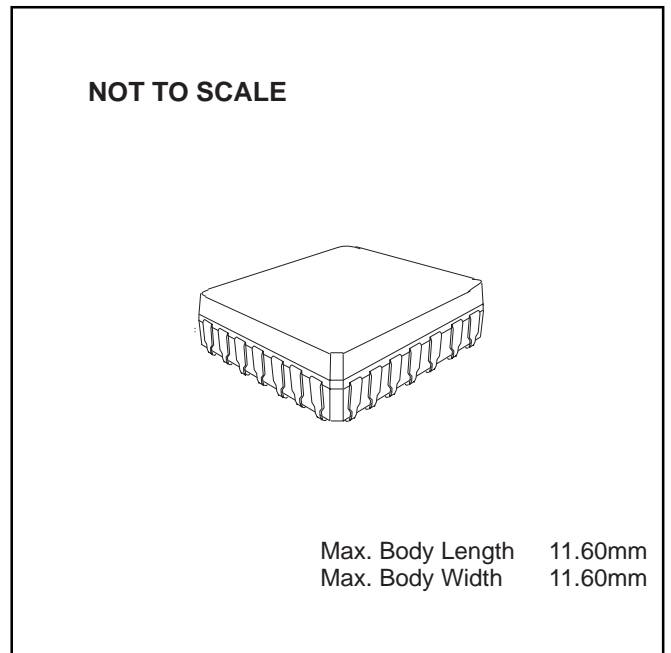

Ordering Information

FX619J 22-pin cerdip DIL (J3)

FX619L1 24-pin quad plastic encapsulated bent and cropped (LG)

FX619L2 24-pin plastic leaded chip carrier (LS)

FX619M1 28-lead ceramic leaded chip carrier (M1)

CML does not assume any responsibility for the use of any circuitry described. No circuit patent licences are implied and CML reserves the right at any time without notice to change the said circuitry.



CML Microcircuits

COMMUNICATION SEMICONDUCTORS

CML Product Data

In the process of creating a more global image, the three standard product semiconductor companies of CML Microsystems Plc (*Consumer Microcircuits Limited (UK)*, *MX-COM, Inc (USA)* and *CML Microcircuits (Singapore) Pte Ltd*) have undergone name changes and, whilst maintaining their separate new names (*CML Microcircuits (UK) Ltd*, *CML Microcircuits (USA) Inc* and *CML Microcircuits (Singapore) Pte Ltd*), now operate under the single title **CML Microcircuits**.

These companies are all 100% owned operating companies of the CML Microsystems Plc Group and these changes are purely changes of name and do not change any underlying legal entities and hence will have no effect on any agreements or contacts currently in force.

CML Microcircuits Product Prefix Codes

Until the latter part of 1996, the differentiator between products manufactured and sold from MXCOM, Inc. and Consumer Microcircuits Limited were denoted by the prefixes MX and FX respectively. These products use the same silicon etc. and today still carry the same prefixes. In the latter part of 1996, both companies adopted the common prefix: CMX.

This notification is relevant product information to which it is attached.

Company contact information is as below:



**CML Microcircuits
(UK) Ltd**

COMMUNICATION SEMICONDUCTORS

Oval Park, Langford, Maldon,
Essex, CM9 6WG, England
Tel: +44 (0)1621 875500
Fax: +44 (0)1621 875600
uk.sales@cmlmicro.com
www.cmlmicro.com



**CML Microcircuits
(USA) Inc.**

COMMUNICATION SEMICONDUCTORS

4800 Bethania Station Road,
Winston-Salem, NC 27105, USA
Tel: +1 336 744 5050,
0800 638 5577
Fax: +1 336 744 5054
us.sales@cmlmicro.com
www.cmlmicro.com



**CML Microcircuits
(Singapore) Pte Ltd**

COMMUNICATION SEMICONDUCTORS

No 2 Kallang Pudding Road, 09-05/
06 Mactech Industrial Building,
Singapore 349307
Tel: +65 7450426
Fax: +65 7452917
sg.sales@cmlmicro.com
www.cmlmicro.com