

Repeaters



R1910G In-Building PCS 1900 GSM Repeater

Holes in your PCS network can result in dropped calls, frustrated subscribers, and lost revenue. Solve your indoor coverage problems quickly and easily with Watkins-Johnson's R1910G in-building repeater. The "over the air" GSM repeater provides coverage to shopping malls, airports, multi-story buildings, small site applications, and other indoor locations that obstruct PCS signals.

Small, lightweight, and easy to install, the R1910G repeater provides in-building coverage in less than a day. One installer can mount the unit and connect it to the antennas with low cost coaxial cables. Simply plug it in and turn it on. Coverage is immediate and seamless. The R1910G also comes with software to monitor signal strength and control frequency channel and gain during the installation procedure.

The standard product is offered in a single channel configuration. Software running Windows 95 and Windows NT allows the installer to monitor alarm and signal information. The interface also allows control of the frequency channel and gain.

- *Covers Buildings up to 1 Million Square Feet*
- *Retail Stores & Shopping Malls*
- *Airport Terminals*
- *Easy Installation*
- *Low Cost*

The Communications Edge™

WJ WIRELESS COMMUNICATIONS PRODUCTS
1-800-WJ1-4401 • FAX: 650-813-2447 • e-mail: wireless.info@wj.com



WATKINS-JOHNSON

Repeaters

R1910G In-Building PCS 1900 GSM Repeater

Specifications	
Frequency Range	Models Available to Cover Bands A, B, C, D, E, F
Output Power	500 mWatts
Filter Bandwidth	200 kHz (contact factory for multicarrier bandwidths)
Noise Figure	4 dB Typical @ max gain, 6 dB Typical @ min gain
Gain Range	65 dB to 95 dB
Gain Steps	2 dB
Signal Delay	5 μ sec.
RF Connectors	Type N
Power supply	110 VAC, 60 Hz, 60 Watts
Alarms & Status	Input Overload, Synthesizers, Amplifiers, Power Amplifiers, Output Power, RSSI
Interface	RS-232, (Modem optional)
Control	Gain, Channel frequency
Cooling	Convection
Temperature	Operating: -10 to +45 C Storage: -40 to +85 C
Size	12" x 16" x 3"
Weight	19 lbs
Weather Resistance	NEMA 12
Approvals and Certification	FCC Type Certified, UL Approved

OUTLINE DRAWING

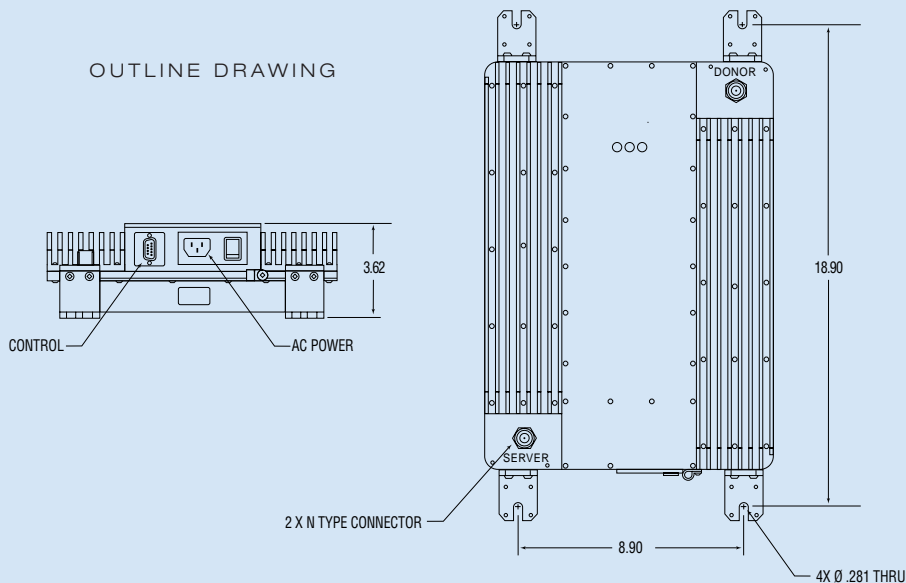

The Communications Edge™