



5.1V + 12V DISABLE VOLTAGE REGULATOR

- Output Currents up to 1A
- Fixed Precision Output 1 Voltage $5.1V \pm 2\%$
- Fixed Precision Output 2 Voltage $12V \pm 2\%$
- Output 1 with Disable by TTL Input
- Output 2 with Disable by TTL Input
- Short Circuit Protection at both Outputs
- Thermal Protection
- Low Drop Output Voltage

DESCRIPTION

The TDA8132 is a monolithic dual positive voltage regulator designed to provide fixed precision output voltages of 5.1V and 12V at currents up to 1A. Each output can be disabled separately by a TTL input.

Short circuit and thermal protections are included.

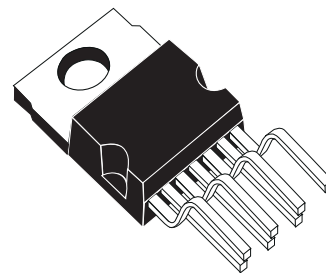

**HEPTAWATT
(Plastic Package)**

ORDER CODES: TDA8132

Figure 1. Pin Connections

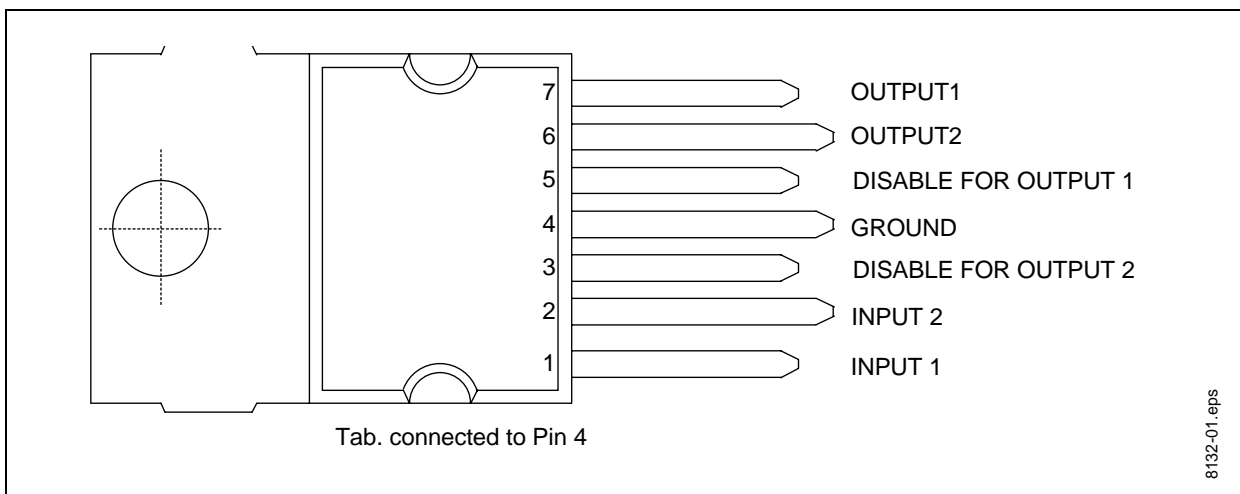
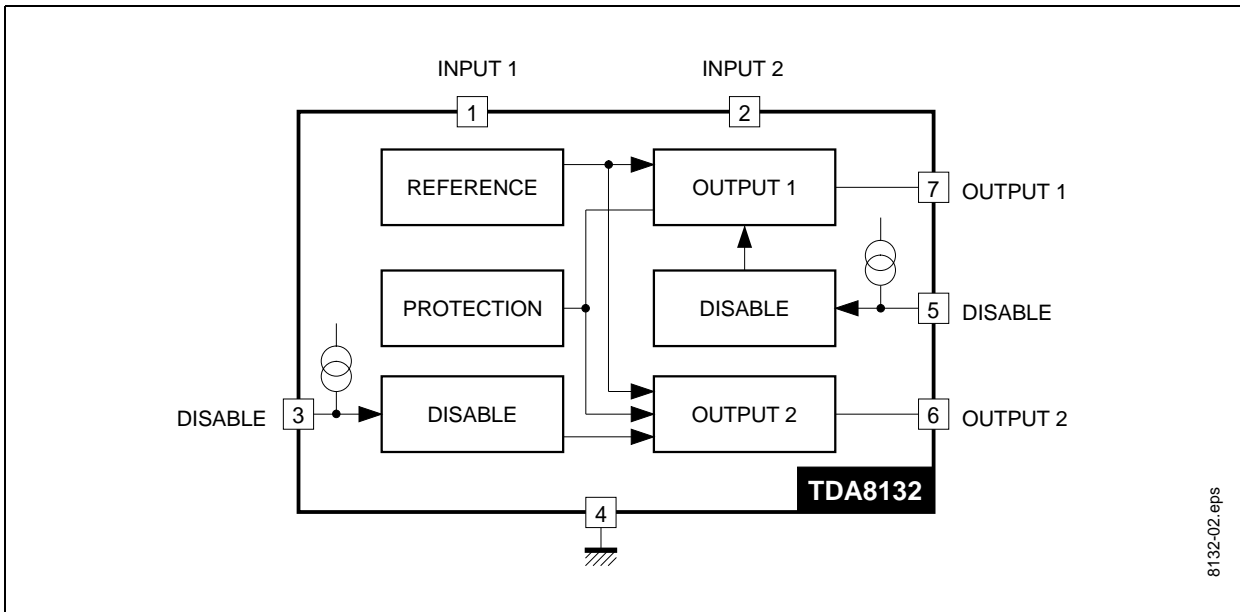

Figure 2. Block Diagram



CIRCUIT DESCRIPTION

The TDA8132 is a dual voltage regulator with separate Disable for each output.

The two regulation parts are supplied from one voltage reference circuit trimmed by zener zap during EWS test.

Since the supply voltage of this last is connected at Pin 1 (V_{IN1}), the regulator 2 will not work if Pin 1 is not supplied.

The outputs stage have been realized in darlington configuration with a drop typical 1.2V.

For each output a disable circuit switches-off this output if a voltage lower than 0.8V is applied at corresponding Pin (Pin 3 for output 2, Pin 5 for output 1).

ABSOLUTE MAXIMUM RATINGS

Symbol	Parameter	Value	Unit
V_{IN}	DC Input Voltage Pin 1	20	V
V_{DIS}	Disable Input Voltage Pin 3-5	20	V
$I_{O1,2}$	Output Currents	Internally Limited	
P_t	Power Dissipation	Internally Limited	
T_{STG}	Storage Temperature	- 65 to + 150	°C
T_J	unction Temperature	0 to + 150	°C

THERMAL DATA

Symbol	Parameter	Value	Unit
$R_{TH(j-c)}$	Thermal Resistance Junction-case	Max. 3	°C/W
T_J	Recommended Junction Temperature	Max. 130	°C

ELECTRICAL CHARACTERISTICS ($V_{IN1} = 7V$, $V_{IN2} = 14V$, $T_J = 25^\circ C$ unless otherwise specified)

Symbol	Parameter	Test Conditions	Min.	Typ.	Max.	Unit
V_{O1}	Output Voltage	$I_{O1} = 10mA$	5	5.1	5.2	V
V_{O2}	Output Voltage	$I_{O2} = 10mA$	11.76	12	12.24	V
V_{O1} V_{O2}	Output Voltage	$5mA < I_{O1,2} < 750mA$ $7V < V_{IN1} < 14V$ $10V < V_{IN2} < 14V$	4.9 11.5		5.3 12.5	V V
$V_{IO1,2}$	Dropout Voltage	$I_{O1,2} = 750mA$ $I_{O1,2} = 1A$			1.4 2	V V
$V_{O1,2LI}$	Line Regulation	$7V < V_{IN1} < 14V$ $10V < V_{IN2} < 14V$ $I_{O1,2} = 200mA$			50 120	mV mV
$V_{O1,2LO}$	Load Regulation	$5mA < I_{O1} < 0.6A$ $5mA < I_{O2} < 0.6A$			100 250	mV mV
I_Q	Quiescent Current	$I_{O1} = 10mA$ Output 2 Disabled			2	mA
$K_{O1,2}$	Output Voltage Thermal Drift	$K_0 = \frac{\Delta V_o \cdot 10^6}{\Delta T \cdot V_o}$ $T_J = 0 \text{ to } +125^\circ C$		100		ppm/ $^\circ C$
$I_{O1,2SC}$	Short Circuit Output Current	$V_{IN1} = 7V$, $V_{IN2} = 14V$ $V_{IN1,2} = 16V$ (see Note)			1.6 1	A A
V_{DISH}	Disable Voltage High (corresponding out active)		2			V
V_{DISL}	Disable Voltage Low (corresponding out disabled)				0.8	V
I_{DIS}	Disable Bias Current	$0V < V_{DIS} < 7V$	-30		2	μA
T_{jSD}	Junction Temperature for Thermal Shut Down			145		$^\circ C$

Note: Safe permanent short-circuit is only guaranteed for input voltages up to 16V.

Figure 3. Typical Application

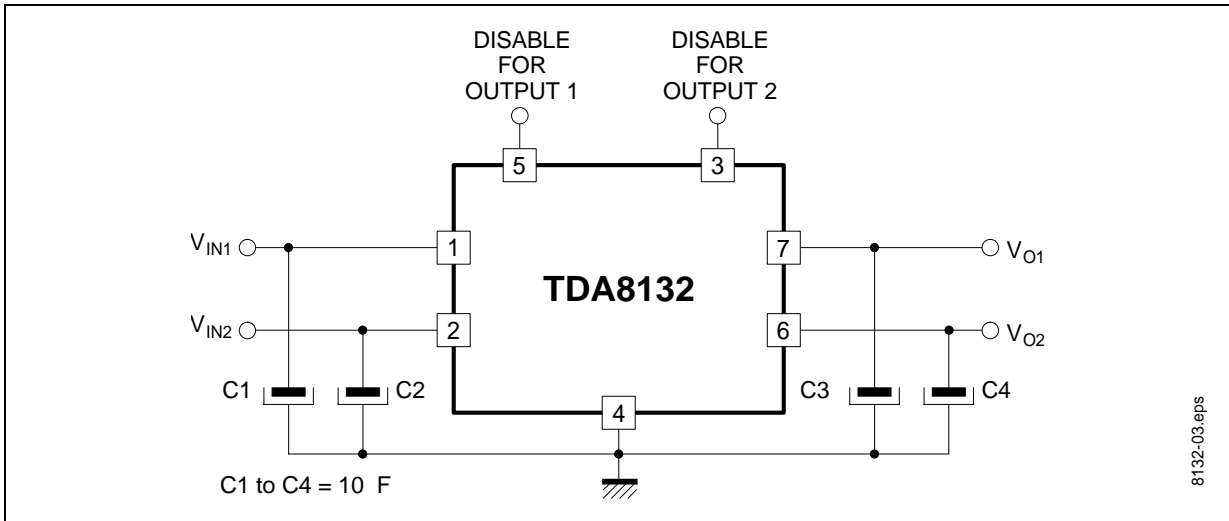

PACKAGE MECHANICAL DATA

9 PINS - PLASTIC HEPTAWATT

Figure 4. 9-Pin Package

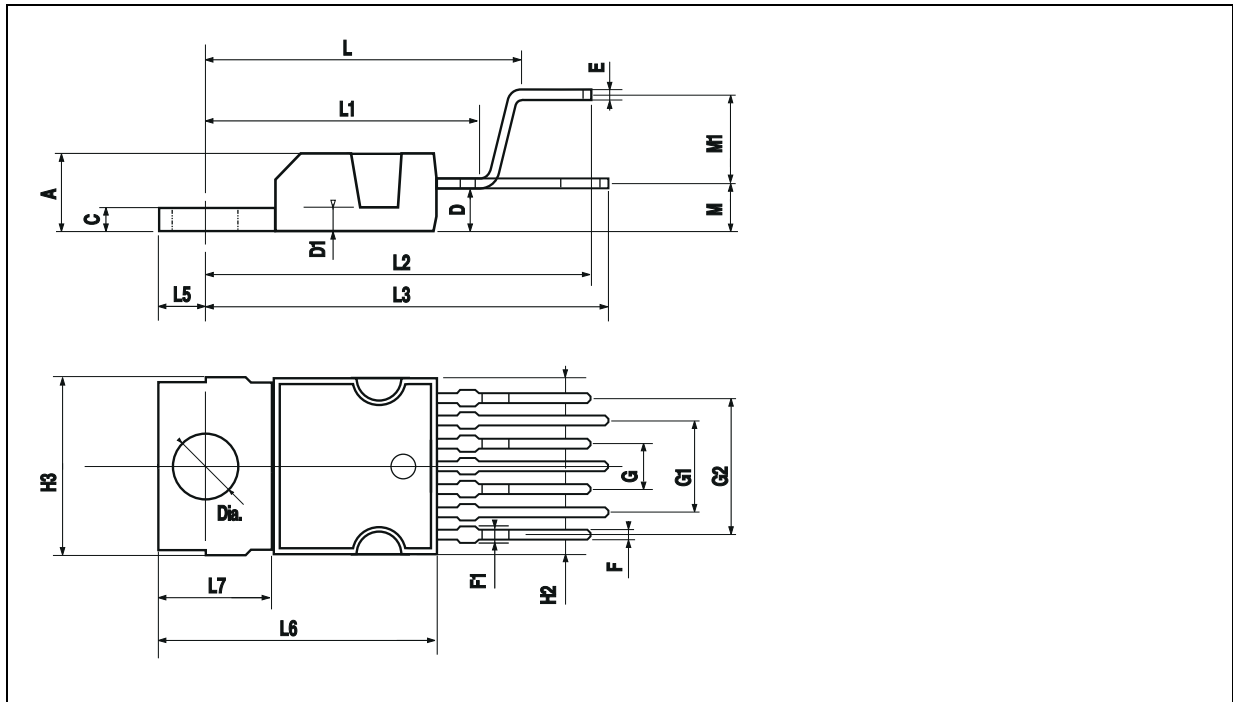

Information furnished is believed to be accurate and reliable. However, STMicroelectronics assumes no responsibility for the consequences of use of such information nor for any infringement of patents or other rights of third parties which may result from its use. No license is granted by implication or otherwise under any patent or patent rights of STMicroelectronics. Specifications mentioned in this publication are subject to change without notice. This publication supersedes and replaces all information previously supplied. STMicroelectronics products are not authorized for use as critical components in life support devices or systems without the express written approval of STMicroelectronics.

The ST logo is a registered trademark of STMicroelectronics

©2003 STMicroelectronics - All Rights Reserved.

Purchase of I²C Components by STMicroelectronics conveys a license under the Philips I²C Patent. Rights to use these components in an I²C system is granted provided that the system conforms to the I²C Standard Specification as defined by Philips.

STMicroelectronics Group of Companies

Australia - Brazil - China - Finland - France - Germany - Hong Kong - India - Italy - Japan - Malaysia - Malta - Morocco - Singapore - Spain
Sweden - Switzerland - United Kingdom - U.S.A.

<http://www.st.com>

This datasheet has been download from:

www.datasheetcatalog.com

Datasheets for electronics components.