

MS-215-3



MS-215-3
Standard Reed Sensor

Electrical Characteristics		@ 25 °C
Contact form		A
Contact rating max.	W / VA	10
Switching voltage max.	VDC	200
	VAC	140
Switching current max.	A	1
Carry current max.	A	1.2
Breakdown voltage min.	VDC	240
Total resistance max. (initial)	mΩ	200
Insulation resistance min.	Ω	10 ¹⁰

Features
➤ Compact size
➤ Mechanically protected
➤ Replaces various competitors types
➤ Customized types available

Magnetical Characteristics (of unmodified Reed Switch)		@ 25 °C
Pull in range available	AT	10 - 25
Drop out min.	AT	4
Test coil	TC	014
Test equipment tolerance	± AT	2

Approvals

Operating Characteristics (of unmodified Reed Switch)		@ 25 °C
Switching frequency max.	Hz	500
Resonant frequency typ.	Hz	4000
Operate time max. (incl. bounce)	ms	1
Release time max.	ms	0.4

Environmental Characteristics		
Operating temperature	°C	-20 to +85
Vibration (50-2000 Hz)	g	20
Shock (1/2 sin 11 ms)	g	100

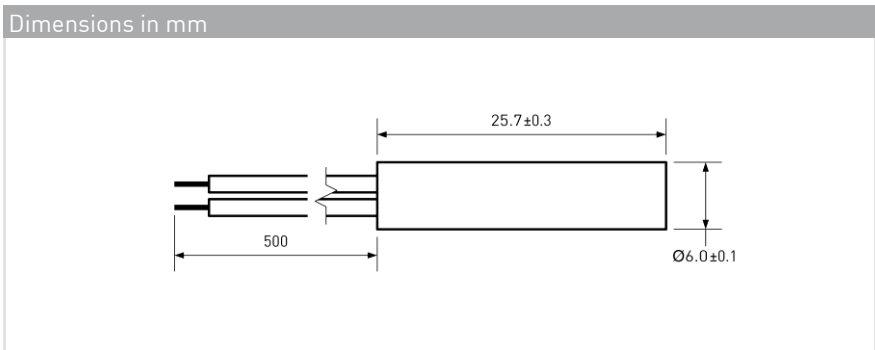

Ordering Information	
Packing Unit	50 pcs
Weight per piece	3.8 g
Weight per package	195 g
Standard AT Ranges	
1	= 10 to 15 AT
2	= 15 to 20 AT
3	= 20 to 25 AT
Ordering Example	
MS-215-3-2-0500 describes MS-215-3 with 15 to 20 AT.	

© PIC GmbH

MS-215-3



MS-215-3
Standard Reed Sensor

Material Information		
	Material	Colour
Housing	ABS	black
Cable	UL 1007/1569, AWG 24, 4 mm stripped and tinned	black
Potting compound	Epoxy	black

Test Procedure of final Reed Sensor

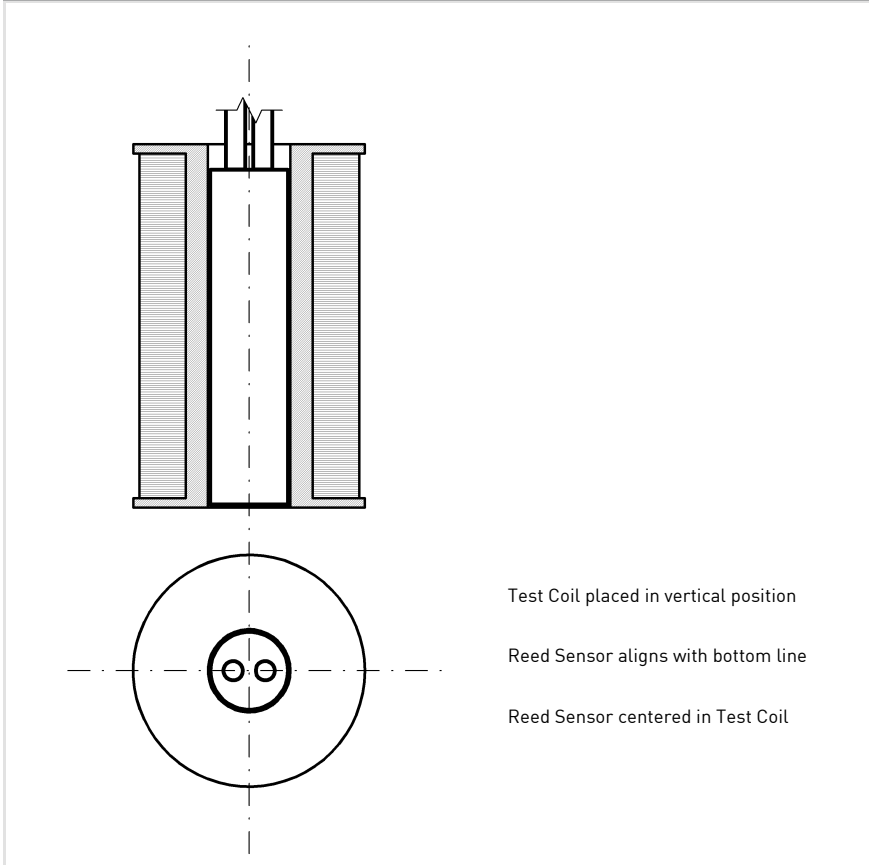

Test Parameters	
Test coil	TC- 093
Test programs	
AT range	Test program
1 =	MS-215-3-1
2 =	MS-215-3-2
3 =	MS-215-3-3

Remarks

When mounted onto ferromagnetic parts switching distance of MS-215-3 may reduce.
Electromagnetical influences and magnetic fields may change the switching behaviour of the sensor.