



HCS473

Data Sheet

Code Hopping Encoder and Transponder

Note the following details of the code protection feature on Microchip devices:

- Microchip products meet the specification contained in their particular Microchip Data Sheet.
- Microchip believes that its family of products is one of the most secure families of its kind on the market today, when used in the intended manner and under normal conditions.
- There are dishonest and possibly illegal methods used to breach the code protection feature. All of these methods, to our knowledge, require using the Microchip products in a manner outside the operating specifications contained in Microchip's Data Sheets. Most likely, the person doing so is engaged in theft of intellectual property.
- Microchip is willing to work with the customer who is concerned about the integrity of their code.
- Neither Microchip nor any other semiconductor manufacturer can guarantee the security of their code. Code protection does not mean that we are guaranteeing the product as "unbreakable."

Code protection is constantly evolving. We at Microchip are committed to continuously improving the code protection features of our products.

Information contained in this publication regarding device applications and the like is intended through suggestion only and may be superseded by updates. It is your responsibility to ensure that your application meets with your specifications. No representation or warranty is given and no liability is assumed by Microchip Technology Incorporated with respect to the accuracy or use of such information, or infringement of patents or other intellectual property rights arising from such use or otherwise. Use of Microchip's products as critical components in life support systems is not authorized except with express written approval by Microchip. No licenses are conveyed, implicitly or otherwise, under any intellectual property rights.

Trademarks

The Microchip name and logo, the Microchip logo, KEELOQ, MPLAB, PIC, PICmicro, PICSTART and PRO MATE are registered trademarks of Microchip Technology Incorporated in the U.S.A. and other countries.

FilterLab, microID, MXDEV, MXLAB, PICMASTER, SEEVAL and The Embedded Control Solutions Company are registered trademarks of Microchip Technology Incorporated in the U.S.A.

dsPIC, dsPICDEM.net, ECONOMONITOR, FanSense, FlexROM, fuzzyLAB, In-Circuit Serial Programming, ICSP, ICEPIC, microPort, Migratable Memory, MPASM, MPLIB, MPLINK, MPSIM, PICC, PICDEM, PICDEM.net, rPIC, Select Mode and Total Endurance are trademarks of Microchip Technology Incorporated in the U.S.A. and other countries.

Serialized Quick Turn Programming (SQTP) is a service mark of Microchip Technology Incorporated in the U.S.A.

All other trademarks mentioned herein are property of their respective companies.

© 2002, Microchip Technology Incorporated, Printed in the U.S.A., All Rights Reserved.

 Printed on recycled paper.



Microchip received QS-9000 quality system certification for its worldwide headquarters, design and wafer fabrication facilities in Chandler and Tempe, Arizona in July 1999 and Mountain View, California in March 2002. The Company's quality system processes and procedures are QS-9000 compliant for its PICmicro® 8-bit MCUs, KEELOQ® code hopping devices, Serial EEPROMs, microperipherals, non-volatile memory and analog products. In addition, Microchip's quality system for the design and manufacture of development systems is ISO 9001 certified.

KEELOQ[®] 3-Axis Transcoder

FEATURES

Encoder Security

- Read protected 64-bit encoder key
- 69-bit transmission length
- 60-bit, read protected seed for secure learning
- Programmable 32-bit serial number
- Non-volatile 16/20-bit synchronization counter

Encoder Operation

- 2.05V to 5.5V operation
- Four switch inputs – up to 15 functions codes
- PWM or Manchester modulation
- Selectable Baud Rate (416 - 5,000 bps)
- Transmissions include button queuing information
- PLL interface

Transponder Security

- 2 read protected 64-bit Challenge/Response keys
- Two IFF encryption algorithms
- 16/32-bit Challenge/Response
- Separate Vehicle ID and Token ID
- 2 vehicles supported
- CRC on all communication

Transponder Operation

- Three sensitive transponder inputs
- Bi-directional transponder communication
- Transponder in/RF out operation
- Anticollision of multiple transponders
- Intelligent damping for high Q-factor LC-circuits
- Low battery operation
- Passive proximity activation
- 64-bit secure user EEPROM
- Fast reaction time

Peripherals

- Low Voltage Detector
- On-board RC oscillator with $\pm 10\%$ variation

Package Types

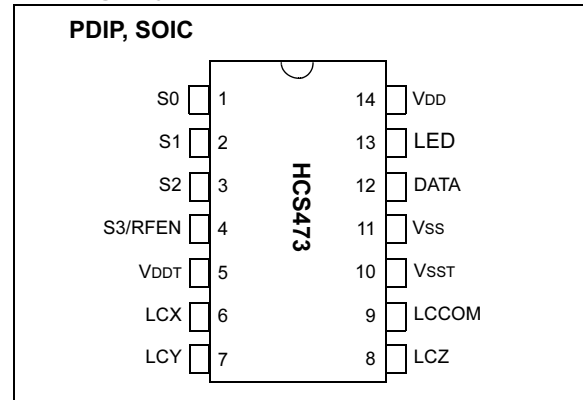

Block Diagram

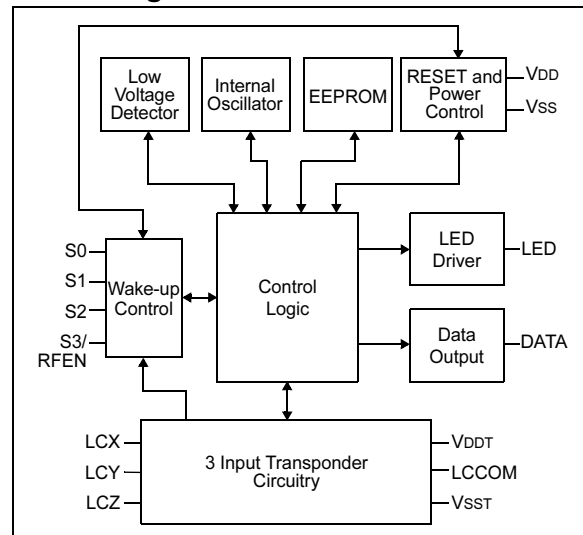

Typical Applications

- Passive entry systems
- Automotive remote entry systems
- Automotive alarm systems
- Automotive immobilizers
- Gate and garage openers
- Electronic door locks (Home/Office/Hotel)
- Burglar alarm systems
- Proximity access control
- Passive proximity authentication

HCS473

Table of Contents

1.0	General Description	3
2.0	Device Description	5
3.0	Device Operation	11
4.0	Programming Specification	37
5.0	Integrating the HCS473 Into A System	39
6.0	Development Support.....	43
7.0	Electrical Characteristics	49
8.0	Packaging Information.....	57
	INDEX	61
	On-Line Support.....	62
	Systems Information and Upgrade Hot Line	62
	Reader Response	63
	Product Identification System.....	64

TO OUR VALUED CUSTOMERS

It is our intention to provide our valued customers with the best documentation possible to ensure successful use of your Microchip products. To this end, we will continue to improve our publications to better suit your needs. Our publications will be refined and enhanced as new volumes and updates are introduced.

If you have any questions or comments regarding this publication, please contact the Marketing Communications Department via E-mail at docerrors@mail.microchip.com or fax the **Reader Response Form** in the back of this data sheet to (480) 792-4150. We welcome your feedback.

Most Current Data Sheet

To obtain the most up-to-date version of this data sheet, please register at our Worldwide Web site at:

<http://www.microchip.com>

You can determine the version of a data sheet by examining its literature number found on the bottom outside corner of any page. The last character of the literature number is the version number, (e.g., DS30000A is version A of document DS30000).

Errata

An errata sheet, describing minor operational differences from the data sheet and recommended workarounds, may exist for current devices. As device/documentation issues become known to us, we will publish an errata sheet. The errata will specify the revision of silicon and revision of document to which it applies.

To determine if an errata sheet exists for a particular device, please check with one of the following:

- Microchip's Worldwide Web site; <http://www.microchip.com>
- Your local Microchip sales office (see last page)
- The Microchip Corporate Literature Center; U.S. FAX: (480) 792-7277

When contacting a sales office or the literature center, please specify which device, revision of silicon and data sheet (include literature number) you are using.

Customer Notification System

Register on our web site at www.microchip.com/cn to receive the most current information on all of our products.

1.0 GENERAL DESCRIPTION

The HCS473 combines the patented KEELOQ code hopping technology and bi-directional transponder challenge-and-response security into a single chip solution for logical and physical access control.

The three-input transponder interface allows the combination of three orthogonal transponder antennas, eliminating the directionality associated with traditional single antenna transponder systems.

When used as a code hopping encoder, the HCS473 is well suited to keyless entry systems; vehicle and garage door access in particular. The same HCS473 can also be used as a secure bi-directional transponder for contactless authentication. These capabilities make the HCS473 ideal for combined secure access control and identification applications, dramatically reducing the cost of hybrid transmitter/transponder solutions.

1.1 System Overview

1.1.1 KEY TERMS

The following is a list of key terms used throughout this data sheet. For additional information on terminology, please refer to the KEELOQ introductory Technical Brief (TB003).

- **AGC** - Automatic Gain Control.
- **Anticollision** - A scheme whereby transponders in the same field can be addressed individually, preventing simultaneous response to a command (Section 3.2.1.4).
- **Button Status** - Indicates what button input(s) activated the transmission. Encompasses the 4 button status bits S3, S2, S1 and S0 (Figure 3-2).
- **Code Hopping** - A method by which a code, viewed externally to the system, appears to change unpredictably each time it is transmitted (Section 1.2.3).
- **Code word** - A block of data that is repeatedly transmitted upon button activation (Figure 3-2).
- **Crypto key** - A unique and secret 64-bit number used to encrypt and decrypt data. In a symmetrical block cipher such as the KEELOQ algorithm, the encryption and decryption keys are equal and will therefore be referred to generally as the crypto key.
- **Decoder** - A device that decodes data received from an encoder.
- **Decryption algorithm** - A recipe whereby data scrambled by an encryption algorithm can be unscrambled using the same crypto key.
- **Device Identifier** - 16-bit value used to uniquely select one of multiple transponders for communication.
- **Encoder** - A device that generates and encodes data.
- **Encryption Algorithm** - A recipe whereby data is scrambled using a crypto key. The data can only be interpreted by the respective decryption algorithm using the same crypto key.
- **IFF** - Identify Friend or Foe, a classic authentication method (Section 3.2.3.3).
- **Learn** - Learning involves the receiver calculating the transmitter's appropriate crypto key, decrypting the received hopping code and storing the serial number, synchronization counter value and crypto key in EEPROM (Section 5.1). The KEELOQ product family facilitates several learning strategies to be implemented on the decoder. The following are examples of what can be done.
- **Simple Learning**
The receiver uses a fixed crypto key, common to all components of all systems by the same manufacturer, to decrypt the received code word's encrypted portion.
- **Normal Learning**
The receiver uses information transmitted during normal operation to derive the crypto key and decrypt the received code word's encrypted portion.
- **Secure Learn**
The transmitter is activated through a special button combination to transmit a stored 60-bit seed value used to derive the transmitter's crypto key. The receiver uses this seed value to calculate the same crypto key and decrypt the received code word's encrypted portion.
- **LF** - Low Frequency. For HCS473 purposes, LF refers to a typical 125 kHz frequency.
- **Manufacturer's code** - A unique and secret 64-bit number used to generate unique encoder crypto keys. Each encoder is programmed with a crypto key that is a function of the manufacturer's code. Each decoder is programmed with the manufacturer code itself.
- **Proximity Activation** - A method whereby an encoder automatically initiates a transmission in response to detecting an inductive field (Section 3.1.1.2).
- **PKE** - Passive Keyless Entry.
- **RKE** - Remote Keyless Entry.
- **Transmission** - A data stream consisting of repeating code words.
- **Transcoder** - Device combining unidirectional transmitter capabilities with bi-directional authentication capabilities.
- **Transponder** - A transmitter-receiver activated for transmission by reception of a predetermined signal.

- **Transponder Reader (Reader, for short)** - A device that authenticates a transponder using bi-directional communication.
- **Transport code** - An access code, 'password' known only by the manufacturer, allowing write access to certain secure device memory areas (Section 3.2.3.2).

1.2 Encoder Overview

The HCS473 code hopping transcoder is designed specifically for passive entry systems; particularly vehicle access. The transcoder portion of a passive entry system is integrated into a fob, carried by the user and operated to gain access to a vehicle or restricted area. The HCS473 is meant to be a cost-effective yet secure solution to such systems, requiring very few external components (Figure 2-1).

1.2.1 LOW-END SYSTEM SECURITY RISKS

Most low-end keyless entry transmitters are given a fixed identification code that is transmitted every time a button is pushed. The number of unique identification codes in a low-end system is usually a relatively small number. These shortcomings provide an opportunity for a sophisticated thief to create a device that 'grabs' a transmission and retransmits it later, or a device that quickly 'scans' all possible identification codes until the correct one is found.

1.2.2 HCS473 SECURITY

The HCS473, on the other hand, employs the KEELOQ code hopping technology coupled with a transmission length of 69 bits to virtually eliminate the use of code 'grabbing' or code 'scanning'. The high security level of the HCS473 is based on the patented KEELOQ technology. A block cipher based on a block length of 32 bits and a key length of 64 bits is used. The algorithm obscures the information in such a way that even if the transmission's pre-encrypted information differs by only one bit from that of the previous transmission, statistically greater than 50 percent of the transmission's encrypted result will change.

1.2.3 HCS473 HOPPING CODE

The 16-bit synchronization counter is the basis behind the transmitted code word changing for each transmission; it increments each time a button is pressed.

Once the device detects a button press, it reads the button inputs and updates the synchronization counter. The synchronization counter and crypto key are input to the encryption algorithm and the output is 32 bits of encrypted information. This encrypted data will change with every button press, its value appearing externally to 'randomly hop around', hence it is referred to as the hopping portion of the code word. The 32-bit hopping code is combined with the button information and serial number to form the code word transmitted to the receiver. The code word format is explained in greater detail in Section 3.1.2.

1.3 Identify Friend or Foe (IFF) Overview

Validation of a transponder first involves an authenticating device sending a random challenge to the device. The transponder then replies with a calculated response that is a function of the received challenge and its stored crypto key. The authenticating device, transponder reader, performs the same calculation and compares it to the transponder's response. If they match, the transponder is identified as valid and the transponder reader can take appropriate action.

The HCS473's IFF response is generated using one of two possible crypto keys. The authenticating device precedes the challenge with a three bit field dictating which key to use in calculating the response.

The bi-directional communication path required for IFF is typically inductive for short range (<10cm) transponder applications with an inductive challenge and inductive response. Longer range (~1.5m) passive entry applications still transmit using the LF inductive path but the response is transmitted RF.

2.0 DEVICE DESCRIPTION

The HCS473 is designed for small package outline, cost-sensitive applications by minimizing the number of external components required for RKE and PKE applications.

Figure 2-1 shows a typical 3-axis HCS473 RKE/PKE application.

- The switch inputs have internal pull-down resistors and integrated debouncing allowing a switch to be directly connected to the inputs.

The transponder circuitry requires only the addition of external LC-resonant circuits for inductive communication capability.

- The open-drain LED output allows an external resistor for customization of LED brightness - and current consumption.
- The DATA output can be directly connected to the RF circuit or connected in conjunction with S3/RFEN to a PLL.

2.1 Pinout Overview

A description of pinouts for the HCS473 can be found in Table 2-1.

TABLE 2-1: PINOUT SUMMARY

Pin Name	Pin Number	Description
S0	1	Button input pin with Schmitt Trigger detector and internal pull-down resistor (Figure 2-3).
S1	2	Button input pin with Schmitt Trigger detector and internal pull-down resistor (Figure 2-3).
S2	3	Button input pin with Schmitt Trigger detector and internal pull-down resistor (Figure 2-3).
S3/RFEN	4	Multi-purpose input/output pin (Figure 2-4). <ul style="list-style-type: none"> • Button input pin with Schmitt Trigger detector and internal pull-down resistor. • RFEN output driver.
VDDT	5	Transponder supply voltage. Regulated voltage output for strong inductive field.
LCX	6	Sensitive transponder input X (Figure 2-7). A strong signal on this pin is internally regulated and supplied on VDD for low-battery operation/recharging.
LCY	7	Sensitive transponder input Y (Figure 2-7)
LCZ	8	Sensitive transponder input Z (Figure 2-7)
LCCOM	9	Transponder bias output (Figure 2-7)
VsST	10	Transponder ground reference, must be connected to VSS.
Vss	11	Ground reference
DATA	12	Transmission data output (Figure 2-5)
LED	13	Open drain LED output (Figure 2-6)
VDD	14	Positive supply voltage

2.2 LF Antenna Considerations

A typical magnetic low frequency sensor (receiving antenna) consists of a parallel inductor-capacitor circuit that is sensitive to an externally applied magnetic signal. This LC circuit is tuned to resonate at the source signal's base frequency. The real-time voltage across the sensor represents the presence and strength of the surrounding magnetic field. By amplitude modulating the source's magnetic field, it is possible to transfer data over short distances. This communication approach is successfully used with distances up to 1.8 meters, depending on transmission strengths and sensor sensitivity. Two key factors that greatly affect communication range are:

1. Sensor tuning
2. A properly tuned sensor's relative sensitivity

An LC antenna's component values may be initially calculated using the following equation. "Initially" because there are many factors affecting component selection.

$$2\pi F = \frac{1}{\sqrt{LC}}$$

It is not this data sheet's purpose to present in-depth details regarding LC antenna and their tuning. Please refer to "Low Frequency Magnetic Transmitter Design Application Note", AN232, for appropriate LF antenna design details.

Note: Microchip also has a confidential Application Note on Magnetic Sensors (AN832C). Contact Microchip for a Non-Disclosure Agreement in order to obtain this application note.

HCS473

FIGURE 2-1: HCS473 3-AXIS APPLICATION

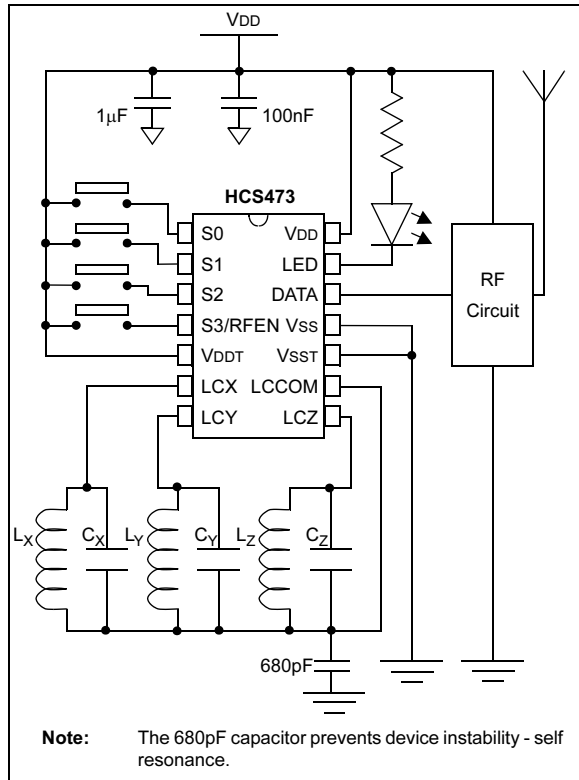

FIGURE 2-2: HCS473 1-AXIS APPLICATION

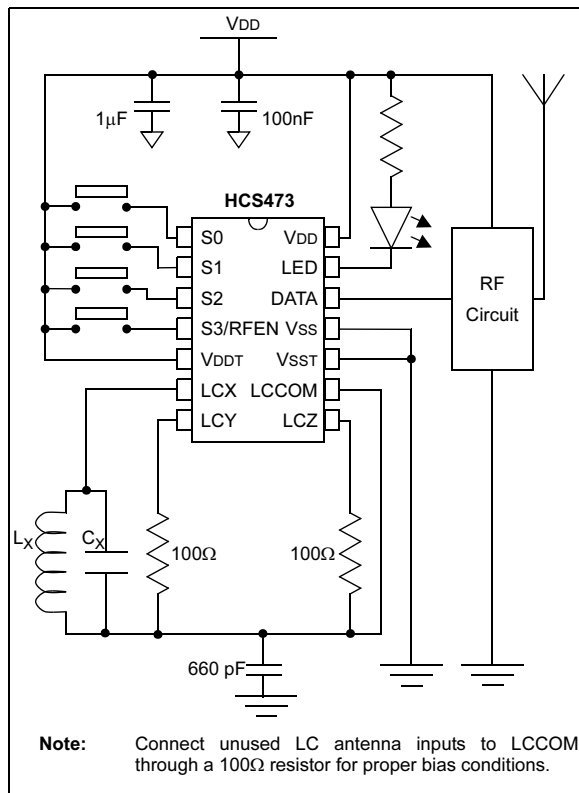

FIGURE 2-3: S0/S1/S2 PIN DIAGRAM

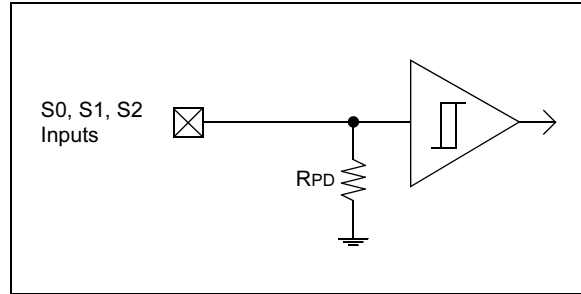

FIGURE 2-4: S3/RFEN PIN DIAGRAM

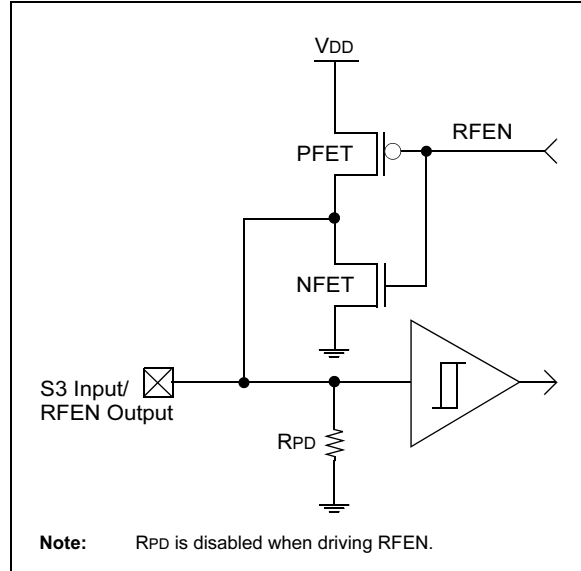

FIGURE 2-5: DATA PIN DIAGRAM

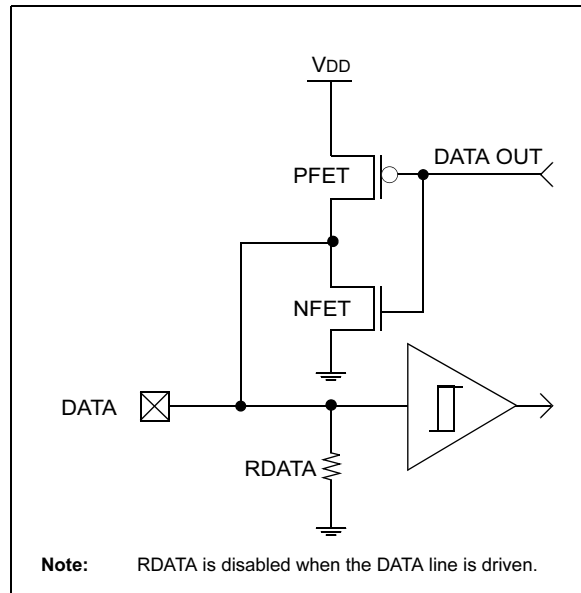

FIGURE 2-6: LED PIN DIAGRAM

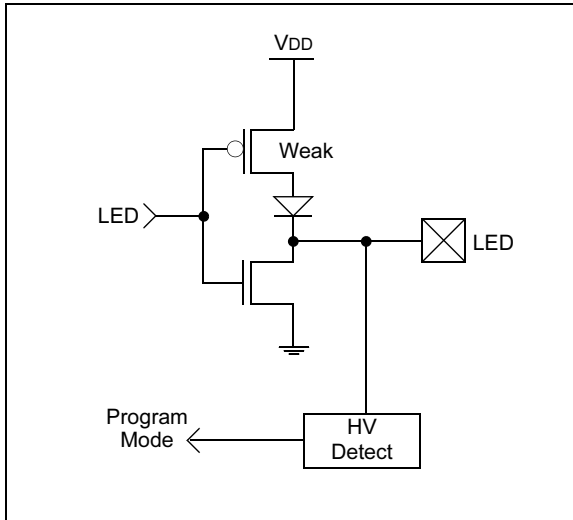
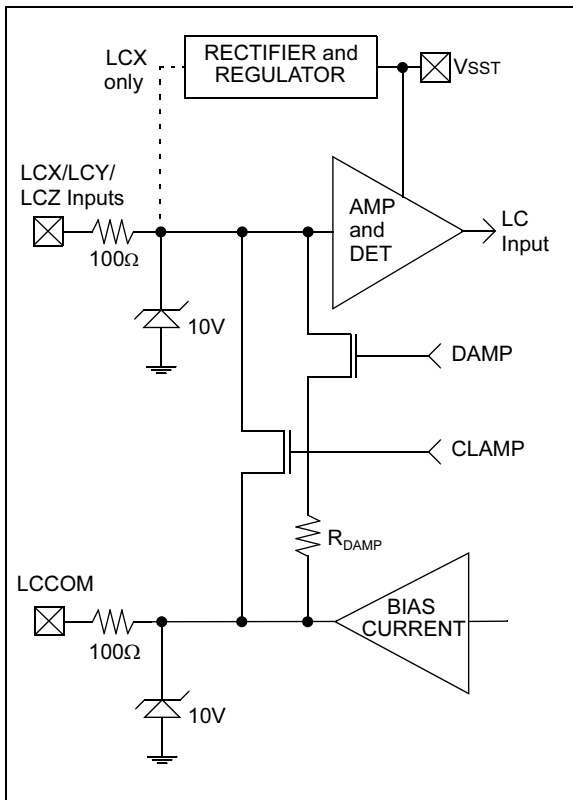

FIGURE 2-7: LCCOM/LCX/LCY/LCZ/ VSST PIN DIAGRAM



2.3 Architectural Overview

2.3.1 WAKE-UP LOGIC

The HCS473 automatically goes into a low-power Standby mode once connected to a supply voltage. Power is supplied to the minimum circuitry required to detect a wake-up condition; button activation or LC signal detection.

The HCS473 will wake from Low-power mode when a button input is pulled high or a signal is detected on a LC low frequency antenna input pin. Waking involves powering the main logic circuitry that controls device operation. The button and transponder inputs are then sampled to determine which input activated the device.

A button input activation places the device into Encoder mode. A signal detected on the transponder input places the device into Transponder mode. Encoder mode has priority over Transponder mode such that communication on the transponder input would be ignored or perhaps interrupted if it occurred simultaneously to a button activation; ignored until the button input is released.

2.3.2 ENCODER INTERFACE

Using the four button inputs, up to 15 unique control codes may be transmitted.

Note: S3 may not be used as a button input if the RFEN option is enabled.

HCS473

2.3.3 TRANSPONDER INTERFACE

The transponder interface on the HCS473 consists of the following:

- The internal transponder circuitry has separate power supply (VDDT) and ground (VSST) connections.
 - The VDDT pin supplies power to the transponder circuitry and also outputs a regulated voltage if the LCX antenna input is receiving a strong signal; transponder is placed in a strong LF field.
 - The VSST pin supplies the ground reference to the transponder circuitry and must be connected to the Vss pin.
- LF input amplifier and envelope detector to detect and shape the incoming low frequency excitation signal.
- Three sensitive transponder inputs with over-voltage protection (LCX, LCY, LCZ).
- Incoming LF energy rectification and regulation on the LCX input to supplement the supply voltage in low-battery transponder instances.
- 10V zener input protection from excessive antenna voltage resulting when proximate to very strong magnetic fields.
- LCCOM pin used to bias the transponder resonant circuits for best sensitivity.
- LF antenna clamping transistors for inductive responses back to the transponder reader. The antenna ends are shorted together, 'clamped', dissipating the oscillatory energy. The reader detects this as a momentary load on its excitation antenna.
- Damping transistors to increase LF communication reliability when using high Q-factor LC antennae.

The LCCOM pin functions to bias the LCX, LCY, and LCZ AGC amplifier inputs. The amplifier gain control sets the optimum level of amplification in respect to the incoming signal strength. The signal then passes through an envelope detector before interpretation in the logic circuit.

A block diagram of the transponder circuit is shown in Figure 2-8.

FIGURE 2-8: HCS473 TRANSPONDER CIRCUIT

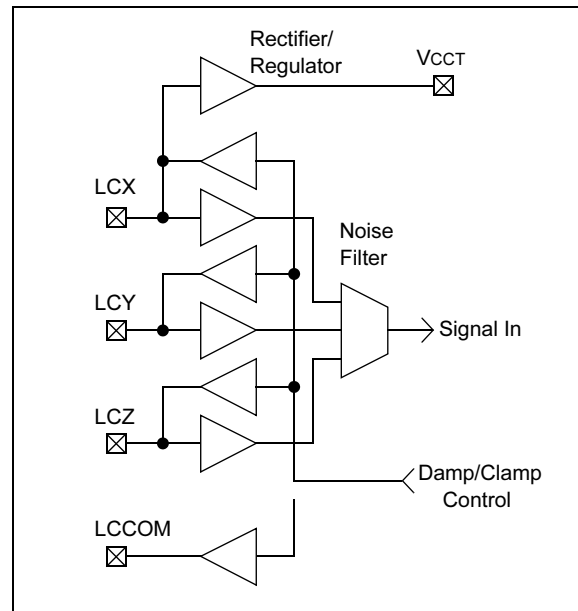

2.3.4 INTERNAL EEPROM

The HCS473 has an on-board non-volatile EEPROM which is used to store:

- configuration options
 - encryption keys
 - serial number
 - vehicle ID's
 - baud rates
 - ... see Section 3.1.4 and Section 3.2.1
- 64 bits of user memory
- synchronization counter.

All options are programmable during production, but many of the security related options are programmable only during production and are further read protected.

The user area allows storage of general purpose information and is accessible only through the transponder communication path.

During every EEPROM write, the device ensures that the internal programming voltage is at an acceptable level prior to performing the EEPROM write.

2.3.5 INTERNAL RC OSCILLATOR

The HCS473 runs on an internal RC oscillator. The internal oscillator may vary $\pm 10\%$ over the device's rated voltage and temperature range for commercial temperature devices. A certain percentage of industrial temperature devices vary further on the slow side, -20%, when used at higher voltages ($V_{DD} > 3.5V$) and cold temperature. The LF and RF communication timing values are subject to these variations.

2.3.6 LOW VOLTAGE DETECTOR

The HCS473's battery voltage detector detects when the supply voltage drops below a predetermined value. The value is selected by the Low Voltage Trip Point Select (VLOWSEL) configuration option (Section 3.3).

The low voltage detector result is included in encoder transmissions (VLOW) allowing the receiver to indicate when the transmitter battery is low (Section 3.1.4.6).

The HCS473 also indicates a low battery condition by changing the LED operation (Section 3.1.5).

2.3.7 THE S3/RFEN PIN

The S3/RFEN pin may be used as a button input or RF enable output to a compatible PLL. Select between S3 button input and RFEN functionality with the RFEN configuration option (Table 2-2).

TABLE 2-2: RFEN OPTION

RFEN	Resulting S3/RFEN Configuration
0	S3 button input pin with Schmitt Trigger detector and internal pull-down resistor.
1	RFEN output driver. S3 may not be used as a button input if the RFEN option is enabled

HCS473

NOTES:

3.0 DEVICE OPERATION

HCS473 operation depends on how the device is activated. The device exits Low-power mode either when a switch input is pulled high or when a signal is detected on an LC antenna input pin. Once activated, the device determines the source of the activation and enters Encoder mode or Transponder mode.

A button input activation places the device into Encoder mode. A signal detected on the transponder input places the device into Transponder mode. Encoder mode has priority over Transponder mode such that communication on the transponder input would be ignored or perhaps interrupted if it occurred simultaneously to a button activation; ignored until the button input is released.

3.1 Encoder mode

3.1.1 ENCODER ACTIVATION

3.1.1.1 Button Activation

The main way to enter Encoder mode is when the wake-up circuit detects a button input activation; button input transition from GND to VDD. The HCS473 control logic wakes and delays a nominal switch debounce time (TDB) prior to sampling the button inputs. The button input states, cumulatively called the button status, determine whether the HCS473 transmits a code hopping or seed transmission.

The transmission begins a time TPU after activation. It consists of a stream of code words transmitted as long as the switch input is held high or until a selectable TSEL timeout occurs (see Section 3.1.4.16 for TSEL options). A timeout returns the device to Low-power mode, protecting the battery in case a button is stuck.

Additional button activations during a transmission will immediately reset the HCS473, perhaps leaving the current code word incomplete. The device will start a new transmission which includes the updated button status value.

Buttons removed during a transmission will have no effect unless no buttons remain activated. If no button activations remain, the minimum number of complete code words will be completed (see Section 3.1.4.15 for MTX options) and the device will return to Low Power mode.

3.1.1.2 Proximity Activation

A second way to enter Encoder mode is if the proximity activation option (PXMA) is enabled and the wake-up circuit detects a wake-up sequence on an LC antenna input pin. This form of activation is called Proximity Activation as a code hopping transmission would be initiated when the device was proximate to a LF field.

3.1.2 TRANSMITTED CODE WORD

The HCS473 transmits a 69-bit code word in response to a button activation or proximity activation, Figure 3-1. The code word content varies with the two unique transmission types; Hopping or Seed.

3.1.2.1 Hopping Code Word

Hopping code words are those transmitted during normal operation. Each Hopping code word contains a preamble, header, 32 bits of encrypted data and up to 37 bits of fixed value data followed by a guard period before another code word begins.

- The 32 bits of **Encrypted Data** include button status bits, discrimination bits and the synchronization counter value. The inclusion/omission of overflow bits and size of both synchronization counter and discrimination bit fields vary with the CNTSEL option, Figure 3-2 and Section 3.1.4.5.
- The 37 bits of **Fixed Code Data** include queue bits (if enabled), CRC bits, low voltage status and serial number. The inclusion/omission of button status and size of the serial number field vary with the XSER option, Figure 3-2 and Section 3.1.4.3.

3.1.2.2 Seed Code Word

Seed code words are required when the system implements secure key generation. Seed transmissions are activated when the button inputs match the value specified by the seed button code configuration option (SDBT), Section 3.1.4.9.

Each Seed code word contains a preamble, header and up to 69 bits of fixed data followed by a guard period before another code word begins.

- The 69 bits of **Fixed Code Data** include queue bits (if enabled), CRC bits, low voltage status, button status and the 60-bit seed value, Figure 3-2.

<p>Note: For additional information on KEELOQ theory and implementation, please refer to the KEELOQ introductory Technical Brief (TB003).</p>
--

HCS473

FIGURE 3-1: GENERAL CODE WORD FORMAT

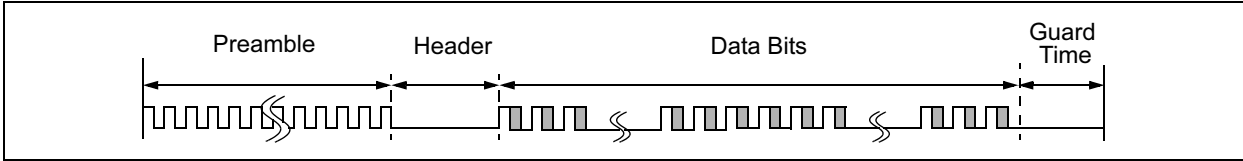
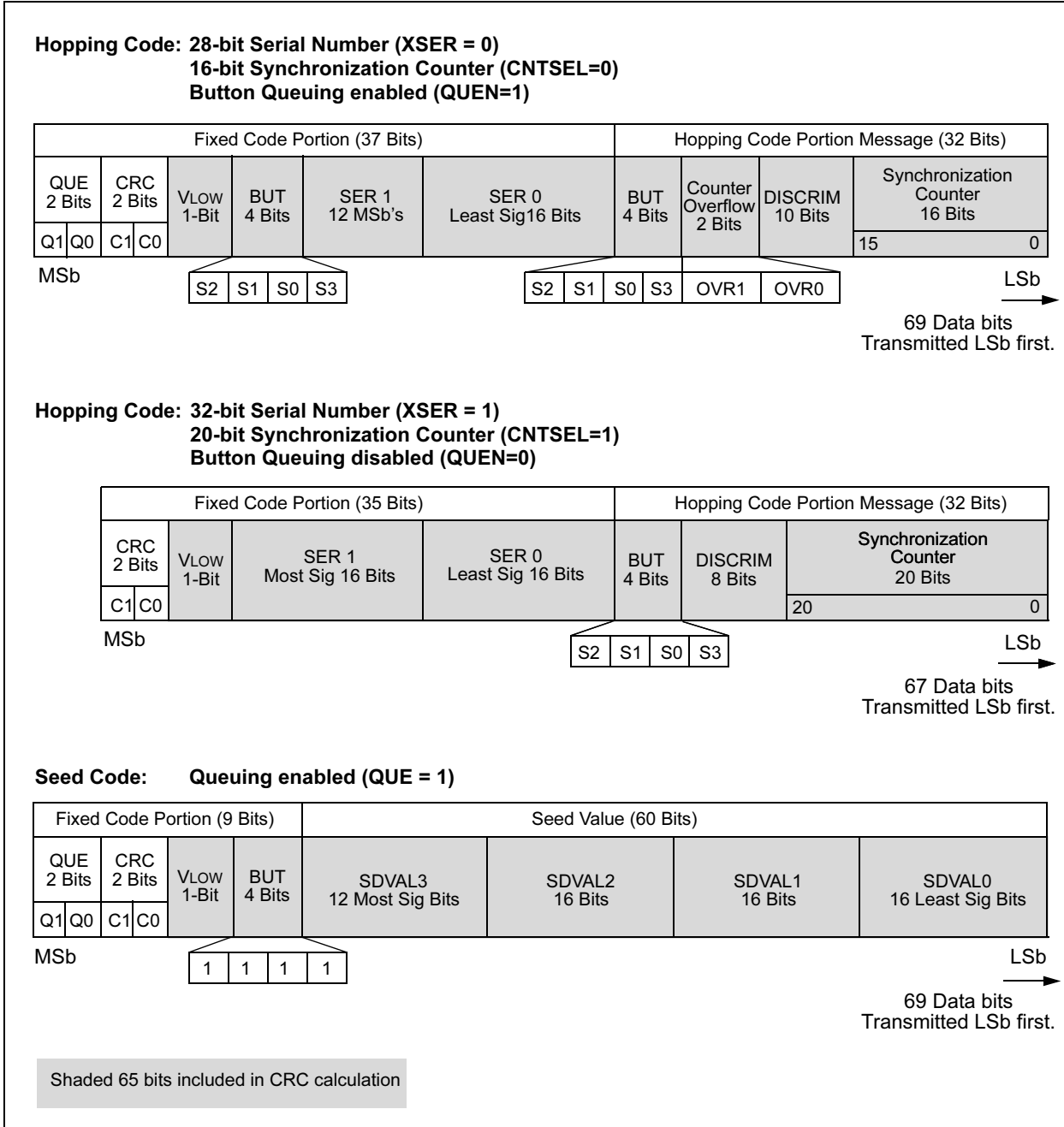

FIGURE 3-2: CODE WORD ORGANIZATION



3.1.3 CODE HOPPING MODULATION FORMAT

The data modulation format is selectable between Pulse Width Modulation (PWM) and Manchester using the modulation select (MSEL) configuration option.

Regardless of the modulation format, each code word contains a leading preamble and a synchronization header to wake the receiver and provide synchronization events for the receive routine. Each code word also contains a trailing guard time to separate code words. Manchester encoding further includes a leading data '1' START pulse and closing 1 RFTE STOP pulse around each data block.

The same code word repeats as long as the same input pins remain active, until a timeout occurs or a delayed seed transmission is activated.

The modulated data timing is typically referred to in multiples of a basic Timing Element (RFTE). 'RF' TE because the DATA pin output is typically sent through a RF transmitter to the decoder or transponder reader.

RFTE may be selected using the RF Transmission Baud Rate (RFBSL) configuration option (Section 3.1.4.13).

FIGURE 3-3: PWM TRANSMISSION FORMAT (MSEL = 0)

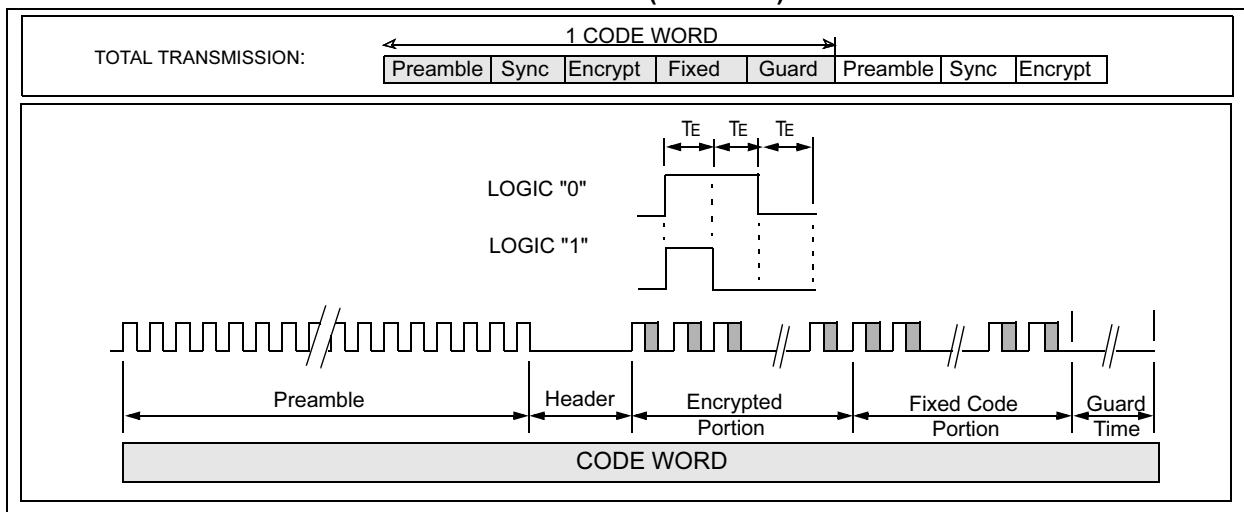
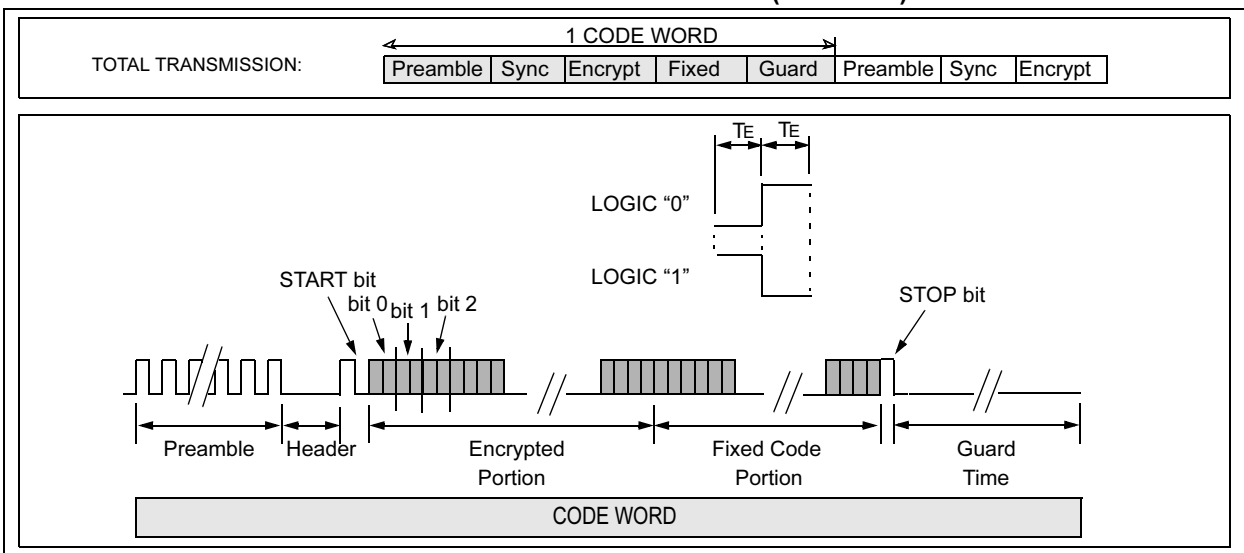

FIGURE 3-4: MANCHESTER TRANSMISSION FORMAT (MSEL = 1)



3.1.4 ENCODER MODE OPTIONS

The following HCS473 configuration options configure transmission characteristics of the information exiting the DATA pin:

- Modulation select (MSEL)
- Header select (HSEL)
- Extended serial number (XSER)
- Queue counter enable (QUEN)
- Counter select (CNTSEL)
- Low voltage trip point (VLOWSEL)
- PLL interface select (AFSK)
- RF enable output (RFEN)
- Seed button code (SDBT)
- Time before Seed (SDTM)
- Limited Seed (SDLM)
- Seed mode (SDMD)
- RF baud rate select (RFBSL)
- Guard time select (GSEL)
- Minimum code words (MTX)
- Timeout select (TSEL)
- Long preamble enable (LPRE)
- Long preamble length (LPRL)
- Preamble duty cycle (PRD)

The following sections detail each configuration's available options. All timing values specified are subject to the specified oscillator variation.

3.1.4.1 Modulation Format (MSEL)

The Modulation format option selects the modulation format for data output from the DATA pin; most often transmitted via RF.

MSEL options:

- Pulse Width Modulation (PWM), Figure 3-3
- Manchester Modulation, Figure 3-4

3.1.4.2 Header Select (HSEL)

The synchronization header is typically used by the receiver to adjust bit sampling appropriate to the transmitter's current speed; as the transmitter's RC oscillator varies with temperature and voltage, so will the transmission's timing.

HSEL options:

- 4 RFTE
- 10 RFTE

3.1.4.3 Extended Serial Number (XSER)

The Extended Serial Number option determines whether the HCS473 transmits a 28 or 32-bit serial number.

When configured for a 28-bit serial number, the Most Significant nibble of the 32 bits reserved for the serial number is replaced with a copy of the 4-bit button status, Figure 3-2.

XSER options:

- 28-bit serial number
- 32-bit serial number

3.1.4.4 Queue Counter (QUEN)

The QUE counter can be used to request secondary decoder functions using only a single transmitter button. Typically a decoder must keep track of incoming transmissions to determine when a double button press occurs, perhaps an unlock all doors request. The QUE counter removes this burden from the decoder by counting multiple button presses and including the QUE counter value in the last two bits of the 69-bit code word, (Figure 3-2). If QUEN is disabled, the transmission will consist only of 67 bits as the QUE bits field is not transmitted.

Que counter functionality is enabled with the QUEN configuration option. The 2-bit QUE counter is incremented each time an active button input is released for at least the Debounce Time (TDB), then re-activated (button pressed again) within the Queue Time (TQUE), Figure 3-5. The counter increments up from 0 to a maximum of 3, returning to 0 only after a different button activation or after button activations spaced greater than the Queue Time (TQUE) apart.

The current transmission aborts, after completing the minimum number of code words (Section 3.1.4.15), when the active button inputs are released. A button re-activation within the queue time (TQUE) then initiates a new transmission (new synchronization counter, encrypted data) using the updated QUE value. Button combinations are queued the same as individual buttons.

FIGURE 3-5: QUE COUNTER TIMING DIAGRAM

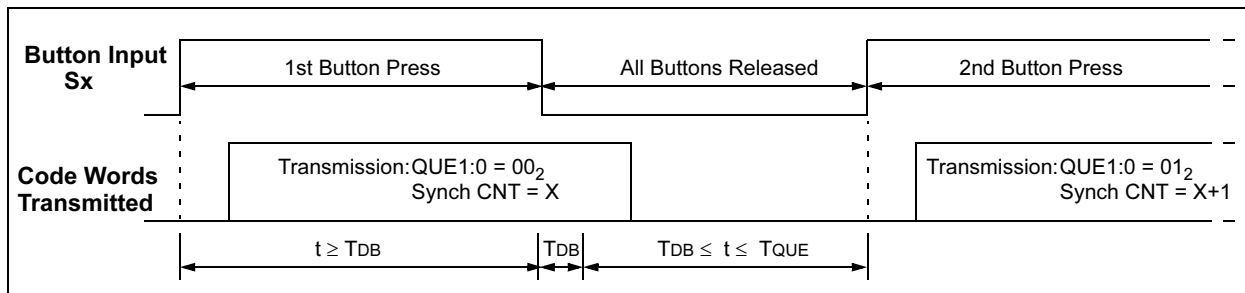

3.1.4.5 Counter Select (CNTSEL)

The counter select option selects between a 16-bit or 20-bit counter. This option changes the way the 32-bit hopping portion is constructed, as indicated in Figure 3-2. The 16-bit counter format additionally includes two overflow bits for increasing the synchronization counter range, see Section 3.1.7.

CNTSEL options:

- 16-bit synchronization counter
- 20-bit synchronization counter

3.1.4.6 Low Voltage Trip Point Select (VLOWSEL)

The HCS473's battery voltage detector detects when the supply voltage drops below a predetermined value. The value is selected by the Low Voltage Trip Point Select (VLOWSEL) configuration option (Table 3-6).

VLOWSEL options:

- 2.2V trip point
- 3.3V trip point

The low voltage detector result (VLOW) is included in Hopping code transmissions allowing the receiver to indicate when the transmitter battery is low (Figure 3-2). The HCS473 also indicates a low battery condition by changing the LED operation (Section 3.1.5).

The HCS473 samples the internal low voltage detector at the end of each code word's first preamble bit. The transmitted VLOW status will be a '0' as long as the low voltage detector indicates VDD is above the selected low voltage trip point. VLOW will change to a '1' if VDD drops below the selected low voltage trip point.

TABLE 3-1: VLOW STATUS BIT

VLOW	Description
0	VDD is above selected trip voltage
1	VDD is below selected trip voltage

3.1.4.7 PLL Interface Select (PLLSEL)

The S3/RFEN pin may be configured as an RF enable output to an RF PLL. The pin's behavior is coordinated with the DATA pin to activate a typical PLL in either ASK or FSK mode.

The PLL Interface (PLLSEL) configuration option controls the output as shown for Encoder operation in Figure 3-6. Please refer to Section 3.2.8 for RFEN behavior during LF communication.

PLLSEL options:

- ASK PLL Setup
- FSK PLL Setup

3.1.4.8 RF Enable Output (RFEN)

The S3/RFEN pin of the HCS473 can be configured to function as an RF enable output signal. When enabled, the pin is driven high whenever data is transmitted through the DATA pin; the S3/RFEN pin can therefore not be used as an input in this configuration. The RF enable option bit functions in conjunction with the PLL interface select option, PLLSEL.

RFEN options:

- S3/RFEN pin functions as S3 switch input only
- S3/RFEN pin functions as RFEN output only

FIGURE 3-6: ENCODER OPERATION: RF ENABLE/ASK/FSK OPTIONS

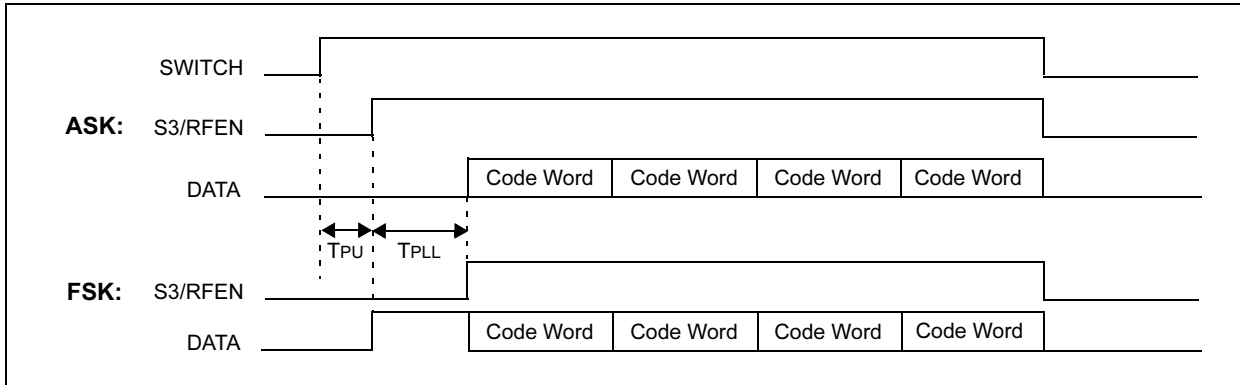

3.1.4.9 SEED Button Code (SDBT)

SDBT selects which switch input(s) activate a seed transmission. Seed transmissions are disabled by clearing all 4 bits. If a button combination is pressed that matches the 4-bit SDBT value, a seed code word is transmitted as configured by the SDTM, SDLM and SDMD options (see following sections).

The binary bit order is S3-S2-S1-S0. For example, if you want the combination of S2 and S0 to activate a seed transmission, use SDBT=0101₂.

SDBT options:

- Seed is transmitted when SDBT flags match the button input flags
- SDBT = 0000₂ disables seed capability.

Note: Configuring S3/RFEN as RFEN (see Section 3.1.4.8) prevents the use of S3 to trigger a seed transmission.

3.1.4.10 Time Before Seed (SDTM)

The time before seed option selects the delay from device activation until the seed code words are transmitted. If the delay is not zero, the HCS473 transmits hopping code words until the selected time, then transmits seed code words.

As code words are always completed, the seed code word begins the first code word after the specified time.

SDTM options:

- 0s - seed code words begin immediately
- 0.8s
- 1.6s
- 3.2s

3.1.4.11 Limited Seed (SDLM)

The limited seed option may be used to disable seed transmission capability after a configurable number of transmitter activations; limiting a transmitter's ability to be learned into a receiver. Specifically, seed transmissions are disabled when the synchronization counter's LSB increments from 7Fh to 80h.

SDLM options:

- unlimited seed capability
- limited seed capability - counter value dependent

3.1.4.12 SEED Mode (SDMD)

The Seed mode option selects between User and Production seed modes. Production mode functions as a special time before seed case (SDTM).

With Production mode enabled, a seed button code activation triggers MTX hopping code words followed by MTX seed code words. Production mode functionality is disabled when the synchronization counter's LSB increments from 7Fh to 80h.

SDMD options:

- User
- Production

3.1.4.13 RF Baud Rate Select (RFBSL)

The timing of code word data modulated on the DATA pin is referred to in multiples of a basic Timing Element RFTE. 'RF' TE because the DATA pin output is typically sent through a RF transmitter to the decoder or transponder reader.

RFTE may be selected using the RF Baud Rate Select (RFBSL) configuration option. RFTE accuracy is subject to the oscillator variation over temperature and voltage.

RFBSL options:

- 100 μ s RFTE
- 200 μ s RFTE
- 400 μ s RFTE
- 800 μ s RFTE

3.1.4.14 Guard Time Select (GSEL)

The guard time (T_G) select option determines the time between consecutive code words when no data is transmitted. The guard time may be selected in conjunction with the RF baud rate and preamble duty cycle to control time-averaged power output for transmitter certification.

GSEL options:

- 3 $RFTE$
- 6.4 ms
- 51.2 ms
- 102.4 ms

3.1.4.15 Minimum Code Words (MTX)

The Minimum Code Words (MTX) configuration option determines the minimum number of code words transmitted when a momentary switch input is taken high for more than TPU, or when a proximity activation occurs.

MTX options:

- 1 code word
- 2 code words
- 4 code words
- 8 code words

3.1.4.16 Timeout Select (TSEL)

The HCS473's Timeout function prevents battery drain should a switch input remain high (stuck button) longer than the selectable TSEL time. After the TSEL time, the device will return to Low-power mode.

The device will stop transmitting in Low-power mode but there will be leakage across the stuck button input's internal pull-down resistor. The current draw will therefore be higher than if no button were stuck.

TSEL options:

- 4s
- 8s
- 16s
- 32s

3.1.4.17 Long Preamble Enable (LPRE)

Enabling the Long Preamble configuration option extends the first code word's preamble to a 'long' preamble time LPRL; allowing the receiver more time to wake and bias before the data bits arrive. The longer preamble will be a square wave at the selected $RFTE$. Subsequent code words begin with the standard preamble length.

LPRE options:

- Standard 16 high pulse preamble
- Long preamble, duration defined by LPRL

3.1.4.18 Long Preamble Length (LPRL)

The long preamble length option selects the first code word's preamble length when the long preamble option (LPRE) is enabled. Only the first code word begins with the long preamble, subsequent code words begin with the standard 16 high pulses preamble.

LPRL options:

- 75 ms
- 100 ms

3.1.4.19 Preamble Duty Cycle (PRD)

The preamble duty cycle can be set to either 33% or 50% to limit the average power transmitted, Figure 3-7.

PRD options:

- 50% Duty Cycle
- 33% Duty Cycle

FIGURE 3-7: PREAMBLE FORMATS

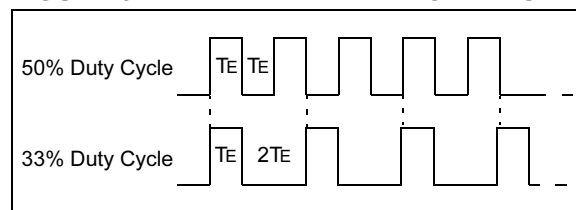

3.1.5 LED OPERATION

The LED pin output varies depending on whether the device V_{DD} is greater than V_{LOWSEL} (a good battery) or below V_{LOWSEL} (a flat battery).

The LED pin will periodically be driven low as long as the device is transmitting and the battery is good. If the supply voltage drops below the specified V_{LOWSEL} trip point, the LED pin will be driven low only once for any given device activation so long as the low battery condition remains (Figure 3-8). If the battery voltage recovers during the transmission, the LED will begin blinking again.

FIGURE 3-8: LED OPERATION

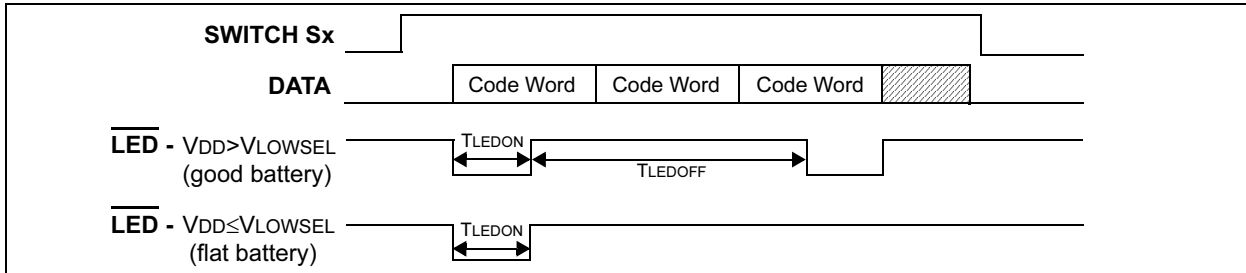

3.1.6 CYCLE REDUNDANCY CHECK (CRC)

The decoder can use the CRC bits to check the data integrity before processing begins. The CRC is calculated on the previously transmitted bits (Figure 3-2), detecting all single bit and 66% of all double bit errors.

EQUATION 3-1: CRC CALCULATION

$$CRC[I]_{n+1} = CRC[0]_n \oplus Di_n$$

and

$$CRC[0]_{n+1} = (CRC[0]_n \oplus Di_n) \oplus CRC[I]_n$$

with

$$CRC[I, 0]_0 = 0$$

and Di_n the n th transmission bit $0 \leq n \leq 64$

3.1.7 COUNTER OVERFLOW BITS (OVR1, OVR0)

The Counter Overflow Bits may be utilized to increase the 16-bit synchronization counter range from the nominal 65,535 to 131,070 or 196,605. The bits do not exist when the device is configured for 20-bit counter operation.

The bits must be programmed during production as '1's to be utilized. OVR0 is cleared the first time the synchronization counter wraps from FFFFh to 0000h. OVR1 is cleared the second time the synchronization counter wraps to zero. The two bits remain at '0' after all subsequent counter wraps.

Note: See Section 4.0, Programming Specs, for information on programming OVR bits.

3.1.8 DISCRIMINATION VALUE (DISC)

The Discrimination Value is typically used by the decoder in a post-decryption check. It may be any value, but in a typical system it will be programmed equal to the Least Significant bits of the serial number.

The discrimination bits are part of the information that form the encrypted portion of the transmission (Figure 3-2). After the receiver has decrypted a transmission, the discrimination bits are checked against the receiver's stored value to verify that the decryption process was valid; appropriate decryption key was used. If the discrimination value was programmed as the LSB's of the serial number then it may merely be compared to the respective bits of the received serial number.

The discrimination bit field size varies with the counter select (CNTSEL) option (Figure 3-2).

3.2 Transponder Mode

The HCS473's Transponder mode allows it to function as a bi-directional communication transponder. Commands are received on the LC pins, responses may be returned on either the LC pins or DATA pin for short range LF or long range RF responses, respectively.

Transponder mode capabilities include:

- A bi-directional challenge and response sequence for IFF validation.
- Read selected EEPROM areas.
- Write selected EEPROM areas.
- Request a code hopping transmission.
- Proximity Activation of a code hopping transmission.
- Address an individual transponder when multiple units are within the LF field; device selection for anticollision communication purposes.

3.2.1 TRANSPONDER OPTIONS

The following HCS473 configuration options influence the device behavior when in Transponder mode:

- Preamble length select (TPRLS)
- LF Demodulator (LFDEMOD)
- LF Baud rate select (LFBSL)
- Anticollision (ACOL)
- Proximity Activation (PXMA)
- Intelligent Damping (DAMP)
- LC response Enable (LCRSP)
- RF response Enable (RFRSP)
- Skip Field Acknowledge (SKIPACK)

The following sections describe these options in detail.

3.2.1.1 Transponder Preamble Length Select (TPRLS)

Data responses through the DATA pin use the format determined by the Encoder mode options, with one exception/option to shorten the response time. The response's preamble can be reduced to 4 high pulses by setting the transponder preamble length select option. This only affects the responses as a result of transponder communication (proximity activation transmissions included), not responses resulting from button input activations. The 4 high pulse short preamble will be at the same duty cycle defined by the preamble duty cycle Encoder mode option (PRD).

Note: The long preamble enable Encoder mode option (LPRE) holds priority over the transponder preamble length option.

TABLE 3-2: TRANSPONDER PREAMBLE LENGTH SELECT (TPRLS)

TPLS	LPRE	Description
0	0	Normal - 16 high pulses
X	1	Long - LPRL determines length
1	0	Short - 4 high pulses

3.2.1.2 LF Demodulator (LFDEMOD)

The HCS473 has a LF Demodulator mode useful for debugging antenna hardware.

Enabling LFDEMOD limits the device to demodulator only mode. After receiving an appropriate wake-up sequence, the device enters a loop demodulating the signal on the LC pins and outputting the resulting digital representation on the LED pin. The HCS473 remains in this mode until no edges are detected on the LC pins for TDEMOM, upon which it will return to Low-power mode; requiring another wake-up sequence to further demodulate data.

The demodulated signal on the LED pin is accurate to within +/-10µs of the signal on the LC pins. The injected signal will have baud rate limitations based on the HCS473's internal filter charge and discharge times, Section 3.2.6.

The filter times discussed in Section 3.2.6 will be easily seen in Demodulator mode. The internal filter delay may be isolated by communicating to the HCS473 inputting the digital signal into LCX and observing the signal plus internal filter delays on the LED pin.

LFDEMOD options:

- Disabled - device functions normally
- Enabled - device demodulates signal on LC pins, outputting digital result on the LED pin.

Note: Damping is disabled when in Demodulator mode.

3.2.1.3 LF Baud Rate Select (LFBSL)

The LF Baud rate select option allows the user to adjust the basic pulse width element (LFTE) used for transponder communication.

LFBSL options:

- 100 µs LFTE
- 200 µs LFTE
- 400 µs LFTE
- 800 µs LFTE

All communication to and from the HCS473 through the LC transponder pins will use the selected LFTE. RF acknowledges to LF communication, through the DATA pin, will also use the selected LFTE.

3.2.1.4 Anticollision (ACOL)

Multiple transponders in the same inductive field will simultaneously respond to inductive commands. Enabling anticollision prevents multiple HCS473 responses from 'colliding'. Hence the term 'anticollision.'

When anticollision (ACOL) is enabled, the first command received after the device wakes must be either the SELECT TRANSPONDER or ANTICOLLISION OFF command before the HCS473 will respond to any other command.

The ANTICOLLISION OFF command may be used to temporarily bypass anticollision requirements for a single communication sequence. It allows communication with an anticollision enabled HCS473 if the VID and TID are not known (perhaps during a learning sequence). See Section 3.2.3.7 for further anticollision off details.

The SELECT TRANSPONDER command allows the addressing of and communication to an individual HCS473, regardless if multiple devices are in the field (Section 3.2.3.1).

HCS473

The HCS473 anticollision method is that all devices trained to a given vehicle will have the same 12-bit vehicle identifier (VID); Most Significant 12 bits of the device identifier, Table 3-3. The device identifier of up to 16 transponders trained to access a given vehicle will differ only in the 4 LSB's. These 4 bits are referred to as the token identifier (TID).

TABLE 3-3: DEVICE ID

16-bit Device ID (DEVID)															
15	14	13	12	11	10	9	8	7	6	5	4	3	2	1	0
VID												TID			
11	10	9	8	7	6	5	4	3	2	1	0	3	2	1	0

The vehicle ID associates the HCS473 with a given vehicle and the token ID makes it a uniquely addressable (selectable) 1 of 16 possible devices authorized to access the vehicle.

Two unique device identifiers are available allowing the HCS473 to be used with two different vehicles. The HCS473 responds if the presented VID and TID match either of the two programmed identifiers.

SELECT TRANSPONDER may still be performed on devices not configured to require anticollision; communication can still be isolated to one of multiple devices in the field. Equally, the same devices will respond to all command sequences not preceded by the SELECT TRANSPONDER sequence.

3.2.1.5 Proximity Activation (PXMA)

Enabling the Proximity Activation configuration option allows the HCS473 to transmit a hopping code transmission in response to detecting an appropriate wake-up pulse on an LC input pin.

The HCS473 sends a wake-up sequence Acknowledge in response to detecting the LF field (Figure 3-11). The device then waits T_{CMD} for the LF field's falling edge followed by the normal T_{CMD} window waiting for a transponder command to begin. If no command is received, a code hopping transmission is generated and the minimum code words (set with MTX option) are transmitted. When the transmission completes, the HCS473 waits a T_{CMD} window for a new command to begin. If no command is received the device returns to SLEEP.

Proximity activations are not repeatedly activated when the device is in the presence of a continuous LF field (computer monitor, tv,...). The HCS473 must receive an appropriate wake-up sequence to activate each transmission.

The button status used in the proximity activated code hopping transmission clears the S0, S1, S2 and S3 button status flags.

3.2.1.6 Intelligent Damping (DAMP)

A high Q-factor LC antenna circuit connected to the HCS473 will continue to resonate after a strong LF field is removed, slowly decaying. The slow decay makes fast communication near the reader difficult as the resulting extended high time makes the following low time disappear.

The Intelligent damping option enables a pulsed, resistive short from the LC pins to LCCOM when the HCS473 is expecting the incoming LC signal level to go low. These pulses damp the antenna, dissipating resonant energy for a quicker decay time when the field is switched off.

The damping pulses are applied between the LCCOM pin and the individual LC pins, starting 1.2 LFTE from detecting the bit's rising edge and repeating until the LC input goes low. Damp pulse width is 6 μ s, beginning every 44 μ s as shown in Figure 3-9.

Note: Damping will not reduce the HCS473 internal LF analog filter discharge time, T_{FILTF} (Section 3.2.6).

FIGURE 3-9: INTELLIGENT DAMPING

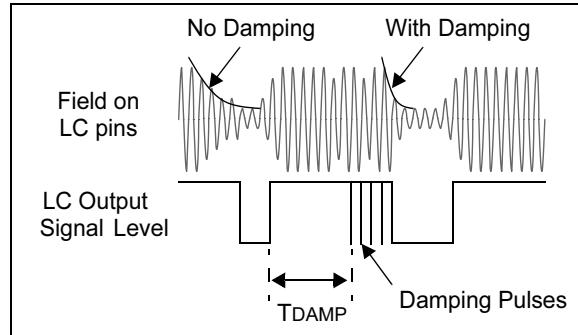

3.2.1.7 Response Options (RFRSP, LCRSP)

HCS473 responses may optionally be returned on the DATA pin for long-range RF responses and/or LC pins for short-range LF responses (Table 3-4). Responses include both Acknowledge sequences and data responses.

The options controlling the response path are:

- LC response option (LCRSP)
- RF response option (RFRSP)

If both RF and LF responses are enabled, Acknowledge pulses will occur simultaneously on the DATA and LC pins; using the LFTE baud rate (Figure 3-11, Figure 3-19). Data responses will not occur simultaneously. The RF response on the DATA pin will occur first (following the designated Encoder mode format), immediately followed by the LF response on the LC pins (Figure 3-20).

TABLE 3-4: HCS473 RESPONSE OPTIONS

RFRSP	LCRSP	Description
0	0	No response
0	1	Response over the LC pins
1	0	Response through the DATA pin
1	1	Response through the DATA pin first and then the LC pins

3.2.1.8 Skip Field Acknowledge (SKIPACK)

The initial Field Acknowledge sequence, occurring during the wake-up pulse, may be disabled by enabling the Skip Field Acknowledge configuration option (SKIPACK=1). Omitting the ACK slightly minimizes a HCS473's average communication current draw, but conversely will increase average authentication time as the wake-up pulse must then be the maximum start-up filter charge time, $T_{SF_{MAX}}$.

3.2.2 TRANSPONDER COMMUNICATION

Data to and from the HCS473 is always sent Least Significant bit first. The data length and modulation format vary with the particular command sequence and the transmission path.

3.2.2.1 LC Communication Format

Commands from the transponder reader to the HCS473 as well as the responses from the HCS473 over the low frequency path (LC pins) are Pulse Position Modulated (PPM) according to Figure 3-10.

Communication from the transponder reader to a HCS473 is via the reader amplitude shifting a 125kHz low frequency (LF) field.

LF responses back to the transponder reader are achieved by the HCS473 applying a low-resistance short from the LC pins to LCCOM (configuration option LCRSP enables LF talkback). This short across the antenna inputs is detected by the reader as a load on its 125kHz transmitting antenna.

See Section 5.4 for further details on inductive communication principles.

FIGURE 3-10: LC PIN PULSE POSITION MODULATION (PPM)

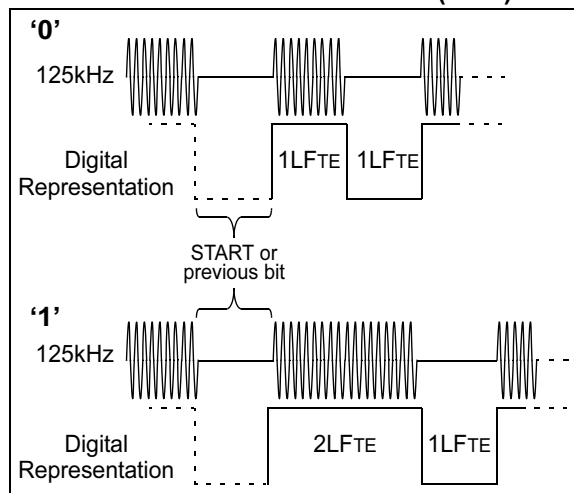

3.2.2.2 RF DATA Communication Format

The RF responses on the DATA pin vary with the information being returned.

- Acknowledge responses are based on the LFTE.
- Data code words responses are based on the RFTE, using the format determined by the Encoder mode options, Section 3.1.4.

3.2.2.3 Wake-up Sequence

The transponder reader initiates each communication sequence by turning on the low frequency field, then waits for a HCS473 to Acknowledge the field.

The HCS473 enters Transponder Mode after detecting a signal on any LC low frequency antenna input pin that has remained high for at least the start-up filter time T_{SF} , Table 7-5. The device then responds with a Field Acknowledge sequence indicating that it has detected the LF field, is in Transponder Mode and is ready to receive commands (Figure 3-11). The wake-up pulse's falling edge must then occur within T_{CMD} of the end of the Field Acknowledge sequence.

The Field Acknowledge sequence may optionally be disabled by enabling the Skip Field ACK configuration option, Section 3.2.1.8.

In both cases, the first command bit must begin within T_{CMD} of the wake-up pulse's falling edge or the HCS473 will return to Low Power mode.

HCS473

3.2.2.4 Command Sequence

The transponder reader follows the HCS473's Field Acknowledge by sending the desired 3-bit command, 3-bit option or address, associated data and CRC; each as required. LF commands are Pulse Position Modulated (PPM) as shown in Figure 3-10. The last bit (CRC bit) should be followed by leaving the field on for T_{FINH}.

T_{FINH} should be appropriately adjusted to receive consecutive commands or LF responses. See Section 3.2.4 and Section 3.2.5 for LF response and consecutive command considerations.

FIGURE 3-11: HCS473 TRANSPONDER WAKE-UP SEQUENCE

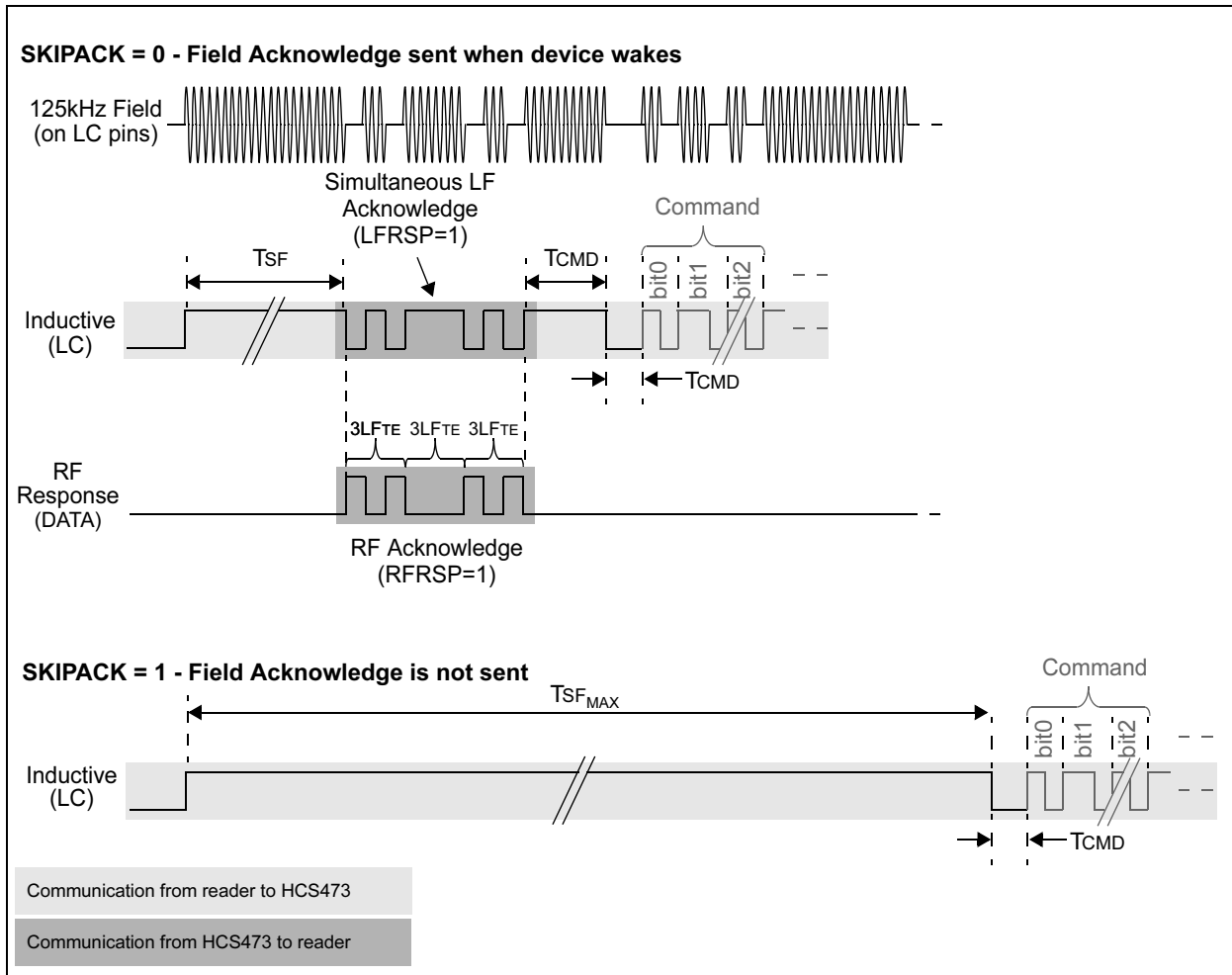

3.2.3 TRANSPONDER COMMANDS

TABLE 3-5: LIST OF AVAILABLE TRANSPONDER COMMANDS

Command	Option	Description
Select Transponder (Section 3.2.3.1)		
000 ₂	-	Select HCS473, used to isolate communication to a single HCS473
Present Transport Code (1) (Section 3.2.3.2)		
001 ₂	-	Used to gain write access to the device EEPROM memory locations
Identify Friend or Foe (IFF) (1) (Section 3.2.3.3)		
010 ₂	000 ₂	32-bit IFF using the Transponder Key
	001 ₂	16-bit IFF using the Transponder Key
	010 ₂	32-bit IFF using the Encoder Key
	011 ₂	16-bit IFF using the Encoder Key
Read EEPROM (1) (Section 3.2.3.4)		
100 ₂	000 ₂	Read 16-bit User EEPROM 0
	001 ₂	Read 16-bit User EEPROM 1
	010 ₂	Read 16-bit User EEPROM 2
	011 ₂	Read 16-bit User EEPROM 3
	100 ₂	Read Most Significant 16 bits of the Serial Number
	101 ₂	Read Least Significant 16 bits of the Serial Number
	110 ₂	Read 16-bit Device Identifier #1 (12-bit Vehicle ID #1 and 4-bit Token ID #1)
	111 ₂	Read 16-bit Device Identifier #2 (12-bit Vehicle ID #2 and 4-bit Token ID #1)
Write EEPROM (1) (2) (Section 3.2.3.5)		
101 ₂	000 ₂	Write 16-bit User EEPROM 0
	001 ₂	Write 16-bit User EEPROM 1
	010 ₂	Write 16-bit User EEPROM 2
	011 ₂	Write 16-bit User EEPROM 3
	100 ₂	Write Most Significant 16 bits of the Serial Number
	101 ₂	Write Least Significant 16 bits of the Serial Number
	110 ₂	Write 16-bit Device Identifier #1 (12-bit Vehicle ID #1 and 4-bit Token ID #1)
	111 ₂	Write 16-bit Device Identifier #2 (12-bit Vehicle ID #2 and 4-bit Token ID #1)
Request Hopping Code (1) (Section 3.2.3.6)		
110 ₂	-	Request Hopping Code transmission
Anticollision OFF (Section 3.2.3.7)		
111 ₂	-	Temporarily bypass a HCS473's anticollision requirements.
<p>Note 1: Command must be preceded by successful Select Transponder or Anticollision Off sequence if anticollision is enabled.</p> <p>2: A successful Present Transport Code sequence must first occur to gain write access.</p>		

HCS473

3.2.3.1 SELECT TRANSPONDER

The SELECT TRANSPONDER sequence must immediately follow the HCS473 wake-up. A 12-bit Vehicle ID (VID) follows the 3-bit command. The 4-bit Token ID (TID) is sent by pulsing the field to identify which transponder should respond.

The HCS473 counts each time the field is pulsed (6 LFTE period), the first pulse setting the counter equal to 0. If the VID matched, the HCS473 will send an Acknowledge when the TID matches the counter. Any further TID pulses after the Acknowledge occurs will deselect the device, putting it back to SLEEP - again requires a wake-up sequence to communicate.

Any HCS473 that did not match both the presented VID and TID will return to SLEEP, unselected, remaining that way until the next wake-up pulse occurs.

The next command must begin TTSCMD after the Acknowledge. If the LC input is high a point $TTSCMD_{MIN}$ after the Acknowledge ends, the HCS473 will return to SLEEP, unselected, assuming the transponder reader is sending additional TID pulse(s) to select a different device. A device of any TID value may therefore be uniquely selected, regardless if a device with lower TID has already acknowledged.

FIGURE 3-12: TRANSPONDER SELECT SEQUENCE (RF RESPONSE EXAMPLE)

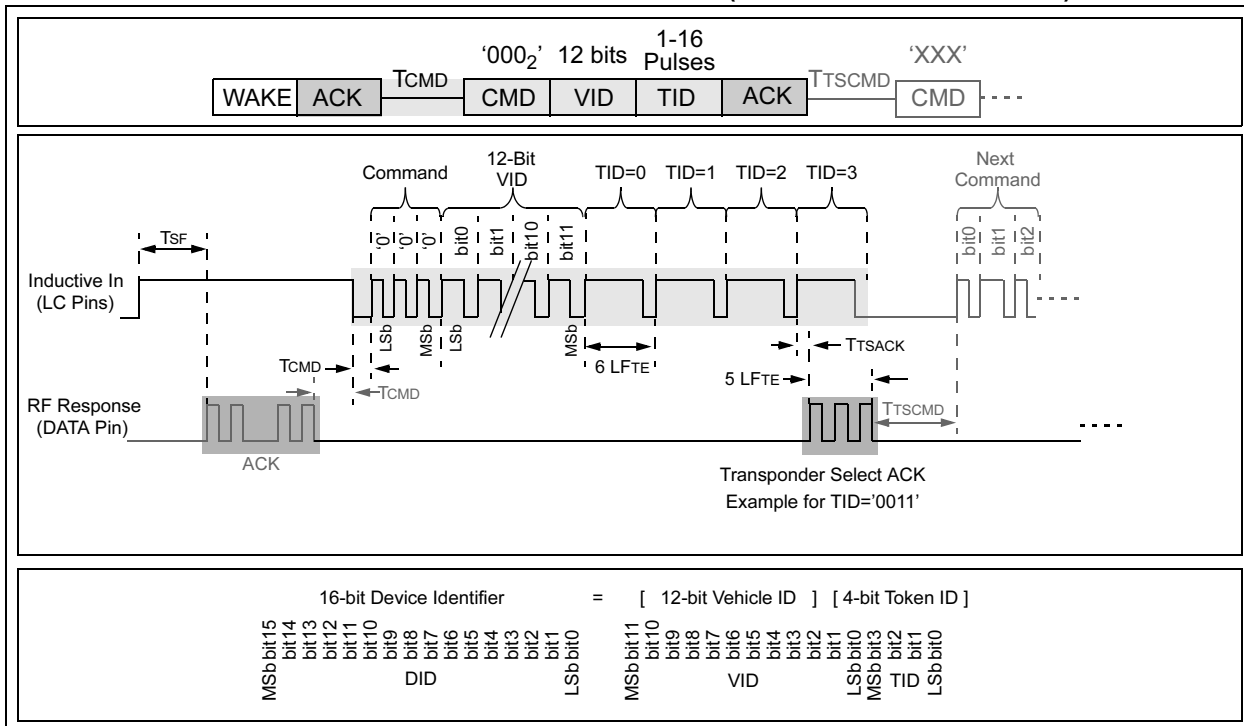

3.2.3.2 PRESENT TRANSPORT CODE

Prior to modifying the device EEPROM, the correct 32-bit transport code (password) must be presented to gain write access. This is done with the PRESENT TRANSPORT CODE command followed by the 32-bit transport code and CRC calculated on the 3-bit command and 32 bits of data.

The HCS473 will return an Acknowledge if the transport code matches the value programmed in production; write access has been granted.

The next command (usually a write) must begin TCMD after the Acknowledge, Figure 3-13.

The present transport code sequence must precede a write sequence but not necessarily immediately. Perhaps all four user memory locations will be written and verified. The present transport code sequence must precede only the first write to gain write access. The system may then alternately write and read (verify) multiple memory locations. Write access remains until the next time the device returns to Low Power mode - communication error or TCMD time out without receiving another command.

FIGURE 3-13: PRESENT TRANSPORT CODE SEQUENCE (RF RESPONSE EXAMPLE)

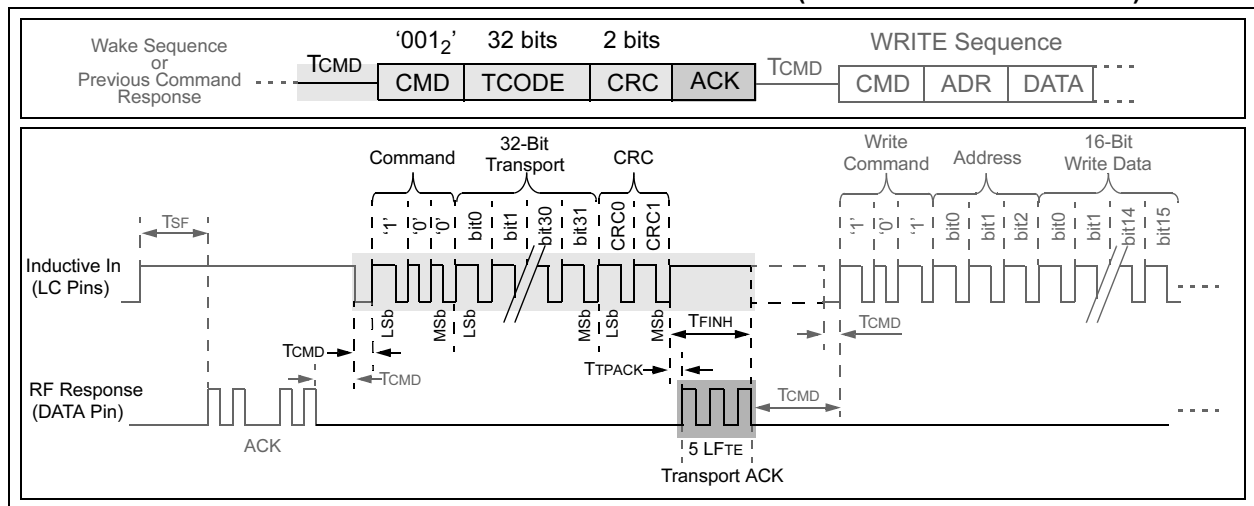

HCS473

3.2.3.3 IFF CHALLENGE AND RESPONSE

The HCS473 can perform a 16-bit or 32-bit challenge and response (IFF) based on the KEELOQ encryption algorithm.

The transponder reader follows the 3-bit IFF command with one of four possible options indicating a 16 or 32-bit challenge and whether to use the encoder or transponder crypto key to create the response (Table 3-5).

The 3-bit option is followed by the appropriate 16 or 32-bit challenge; typically a random number. The sequence ends with a CRC calculated over the command, option and challenge bits, (Figure 3-14).

The HCS473 encrypts the challenge using the designated crypto key and responds with a 32-bit result. The reader authenticates the response by decrypting it and verifying it matches the original challenge.

If 16-bit IFF is selected, the 32-bit response consists of two copies of the 16-bit challenge.

RFRSP determines if the response will be transmitted on the DATA pin. If enabled, the response will follow the selected Encoder mode code hopping format with the hopping code replaced with the 32-bit response. The transmissions will contain a button code of '0000'.

LFRSP determines if the response will be transmitted on the LC pins. The LC pin response will be the 32-bit result, modulated PPM format.

If both RFRSP and LFRSP are enabled, the HCS473 will send the response on the DATA pin immediately followed by the PPM response on the LC pins. Refer to Section 3.2.1.7 for further response path details.

The next command must begin TCMD after the response.

FIGURE 3-14: IFF SEQUENCE (RF RESPONSE EXAMPLE)

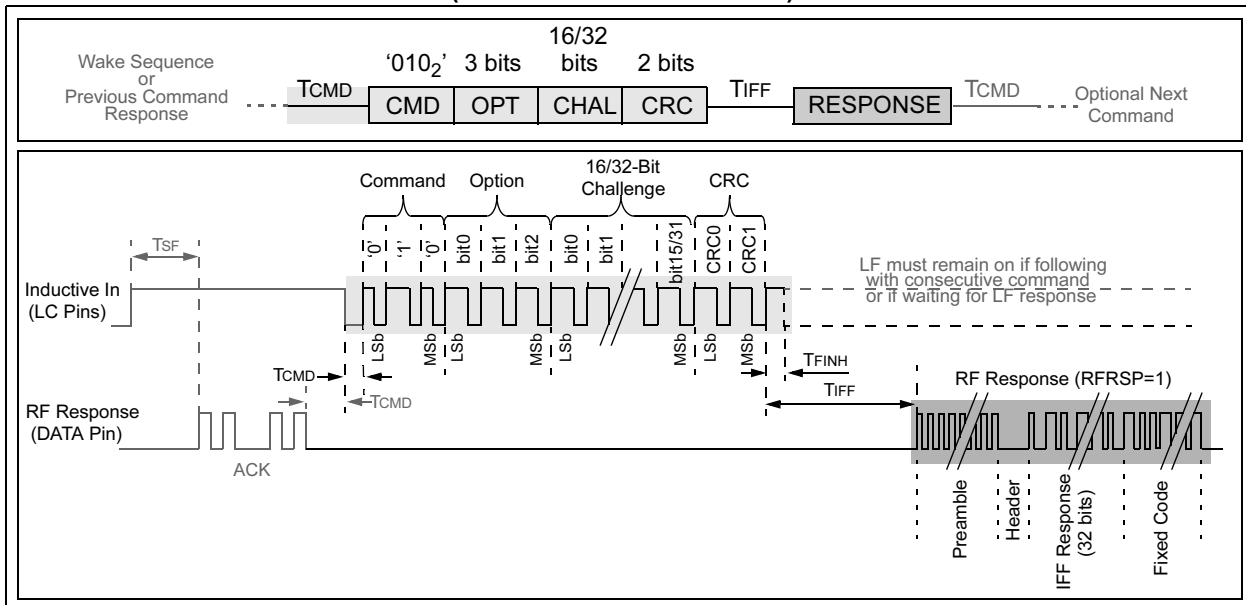

3.2.3.4 READ Command

The transponder reader follows the 3-bit READ command with one of eight possible 3-bit address options indicating which 16-bit EEPROM word to retrieve (Table 3-5) and a 2-bit CRC calculated over the command and address bits.

The HCS473 retrieves the data and returns the 16-bit response by creating a 32-bit value containing two copies of the response (Figure 3-15).

RFRSP determines if the response will be transmitted on the DATA pin. If enabled, the response will follow the selected Encoder mode code hopping format with the hopping code replaced with the 32-bit response. The transmissions will contain a button code of '0000'.

LFRSP determines if the response will be transmitted on the LC pins. The LC pin response will be the 32-bit result, modulated PPM format.

If both RFRSP and LFRSP are enabled, the HCS473 will send the response on the DATA pin immediately followed by the PPM response on the LC pins. Refer to Section 3.2.1.7 for further response path details.

The following locations are available to read:

- The 64-bit general purpose user EEPROM.
- The 32-bit serial number. The serial number is also transmitted in each code hopping transmission.
- The 16-bit device identifiers #1 and #2.

The next command must begin TCMD after the read response.

FIGURE 3-15: READ SEQUENCE (RF RESPONSE EXAMPLE)

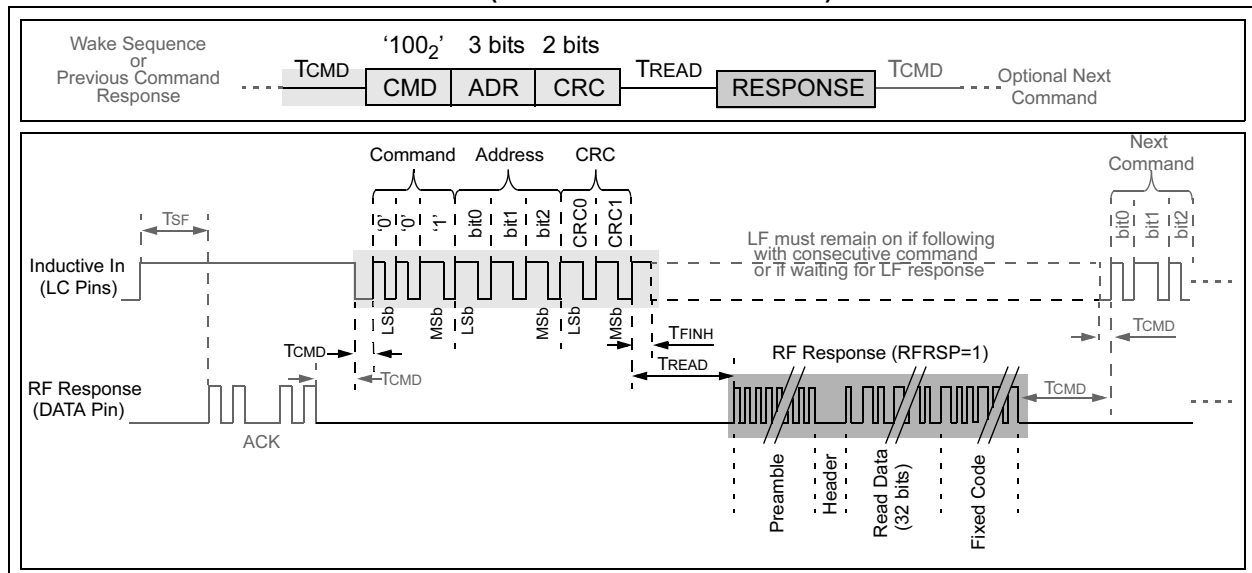

HCS473

3.2.3.5 WRITE Command

The transponder reader follows the 3-bit WRITE command with one of eight possible 3-bit address options indicating which 16-bit EEPROM word to write to (Table 3-5) and a 2-bit CRC calculated over the command, address and data bits.

The HCS473 will attempt to write the value into EEPROM, responding with an Acknowledge sequence if successful (Figure 3-15).

The following locations are available to write:

- The 64-bit general purpose user EEPROM.
- The 32-bit serial number.
- The 16-bit Device Identifiers #1 and #2.

A Transport Code, write access password, protects the memory locations from undesired modification. The reader must precede the Write sequence with a suc-

cessful PRESENT TRANSPORT CODE sequence. Only a correct match with the transport code programmed during production will allow write access to the memory locations.

The next command must begin TcMD after the write Acknowledge.

The PRESENT TRANSPORT CODE sequence must precede a WRITE sequence but not necessarily immediately. Perhaps all four user memory locations will be written and verified. The PRESENT TRANSPORT CODE sequence must precede only the first write. The system may then alternately write and read (verify) multiple memory locations. Write access status remains until the next time the device returns to sleep - communication error or TcMD without receiving another command.

FIGURE 3-16: WRITE SEQUENCE (RF RESPONSE EXAMPLE)

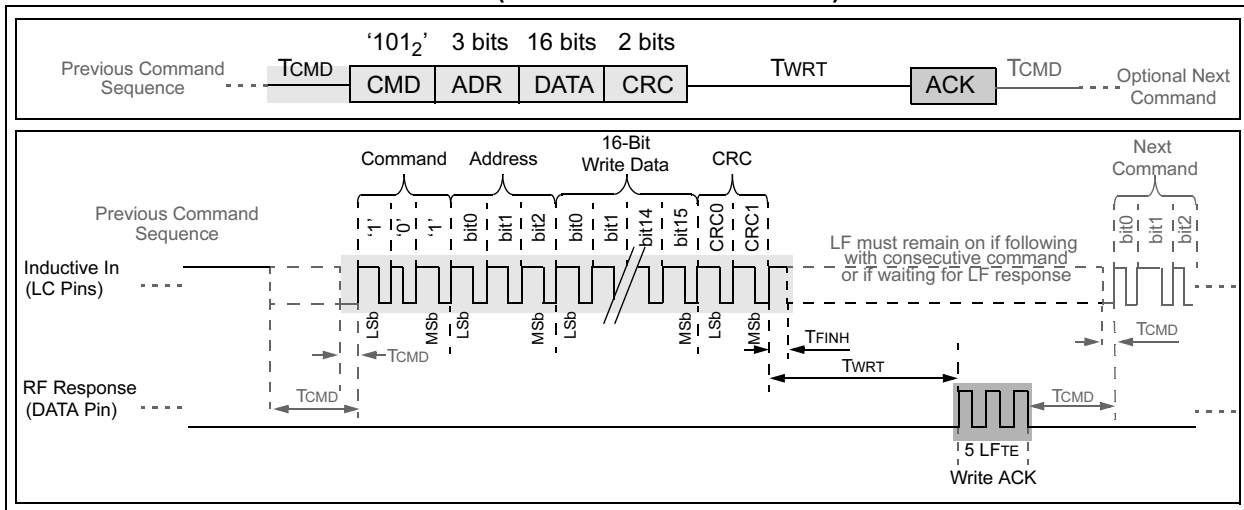

3.2.3.6 REQUEST HOPPING CODE COMMAND

The REQUEST HOPPING CODE command tells the HCS473 to increment the synchronization counter and build the 32-bit code hopping portion of the encoder code word.

A delay of THOP occurs while the HCS473 increments the counter (updating EEPROM values) and encrypts the response.

RFRSP determines if the response will be transmitted on the DATA pin. If enabled, the response will be a single KEELOQ code hopping code word, based on

Encoder mode options. The code word will contain a button code of '0000₂', indicating the transmission did not result from a button press.

LFRSP determines if the response will be transmitted on the LC pins. The LC pin response will be the 32-bit hopping portion of the code word, modulated PPM format.

If both RFRSP and LFRSP are enabled, the HCS473 will send the response on the DATA pin immediately followed by the PPM response on the LC pins. Refer to Section 3.2.1.7 for further response path details.

The next command must begin TCMD after the code hopping response.

FIGURE 3-17: REQUEST HOPPING CODE SEQUENCE (RF RESPONSE EXAMPLE)

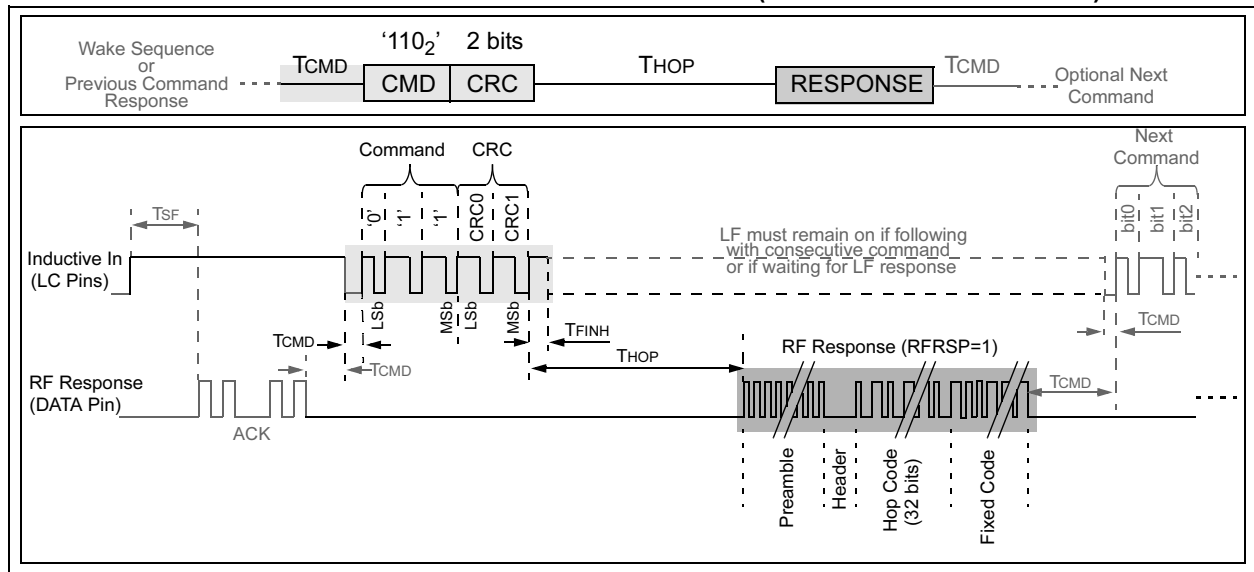

HCS473

3.2.3.7 ANTI-COLLISION OFF

Anticollision is enabled/disabled for a given device by the ACOL configuration option. The ANTICOLLISION OFF command may be used to temporarily bypass anticollision requirements for a single communication sequence. It allows communication to an anticollision enabled HCS473 if the VID and TID are not known (perhaps during a learning sequence).

The command must immediately follow the wake-up sequence, Figure 3-18. The HCS473 acknowledges the command receipt, then reacts to all commands

even if the anticollision (ACOL) configuration option is enabled and a SELECT TRANSPONDER sequence has not been performed.

The next command must begin TcMD after the Acknowledge.

The HCS473 remains in this anticollision off state until the next time the device returns to SLEEP - communication error or TcMD without receiving another command. Multiple commands may therefore be sent without sending the ANTICOLLISION OFF command prior to each command.

FIGURE 3-18: ANTICOLLISION OFF SEQUENCE (RF RESPONSE EXAMPLE)

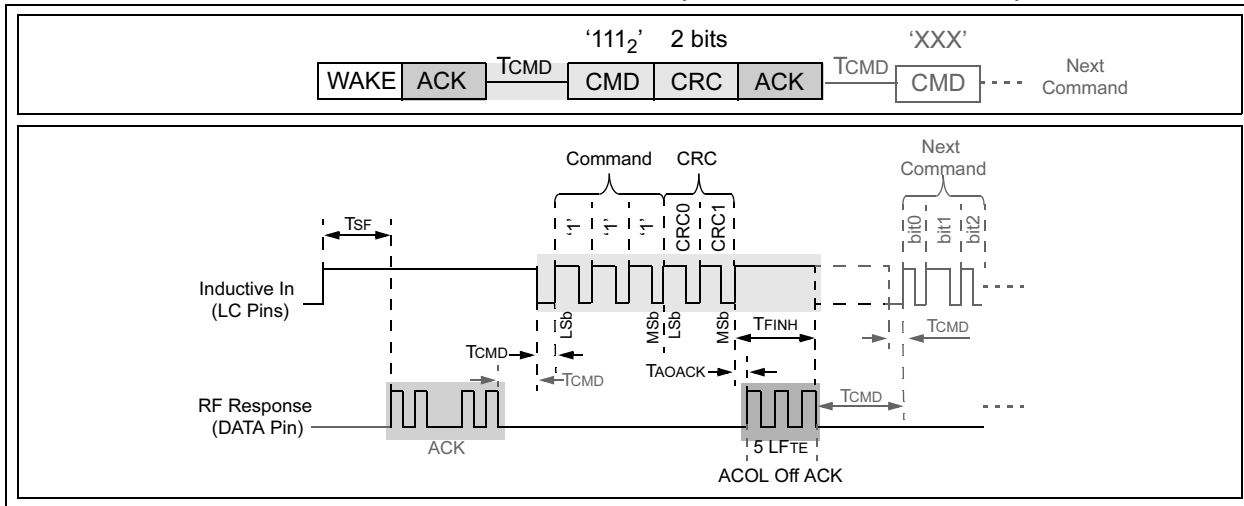

3.2.4 LF RESPONSE CONSIDERATIONS

As LF responses are transmitted by the HCS473 placing a short across the LC antenna inputs, dissipating the antenna resonance, the transponder reader must still be sending the 125 kHz field for LF responses to work. The low frequency field on-time (T_{FINH}) must therefore be appropriately adjusted to receive an LF Acknowledge sequence or LF data response, Figure 3-19 and Figure 3-20.

3.2.5 CONSECUTIVE COMMAND CONSIDERATIONS

Transponder commands may consecutively follow one another to minimize communication time as the wake-up sequence, device selection, anticollision off and transport code presentation need not be repeated for every command.

Consideration must be given to how long the transponder reader keeps the LF signal on after the last data bit's rising edge (T_{FINH}) when a command sequence...

- will be followed by another command sequence
- will result in a LF response

The reason is that the HCS473's analog LF antenna input circuitry will return to Low-power mode when the 125 kHz field remains absent; requiring a new wake-up sequence to continue communication.

The HCS473's analog section will never return to Low-power mode during any TcMD window waiting for an LC input communication edge, so long as the LF signal existed up to the beginning of the TcMD window.

Please refer to Figure 3-19 and Figure 3-20 for examples on adjusting T_{FINH} for consecutive commands and LF responses.

3.2.6 LF COMMUNICATION ANALOG DELAYS

LF communication edge delays result from the HCS473's internal analog circuit as well as the external LC resonant antennas, Figure 3-21.

The rising and falling edge delays inherent to the HCS473's internal filtering are known and specified in Table 7-5, T_{FILTR} and T_{FILTF}.

The cumulative rising and falling edge delays inherent to both the series LC transmitting antenna and parallel LC receiving antennas are design dependent, not a HCS473 specification.

Table 7-5 timing values are compensated only for HCS473 internal filter delays. The transponder reader designer must compensate communication timing accordingly for the cumulative antenna delays.

Use LF Demodulator mode to see the effects of the internal filters and the LC antennae, Section 3.2.1.2.

It must be clearly understood that the HCS473 core does not see the LF field immediately upon the base station turning it on, nor does it immediately detect its removal. If the internal analog delay and cumulative antenna delays are greater than a given low time, the HCS473 will obviously never "see" the low.

FIGURE 3-19: LF ACK RESPONSE ADJUSTMENTS (LFRSP=1)

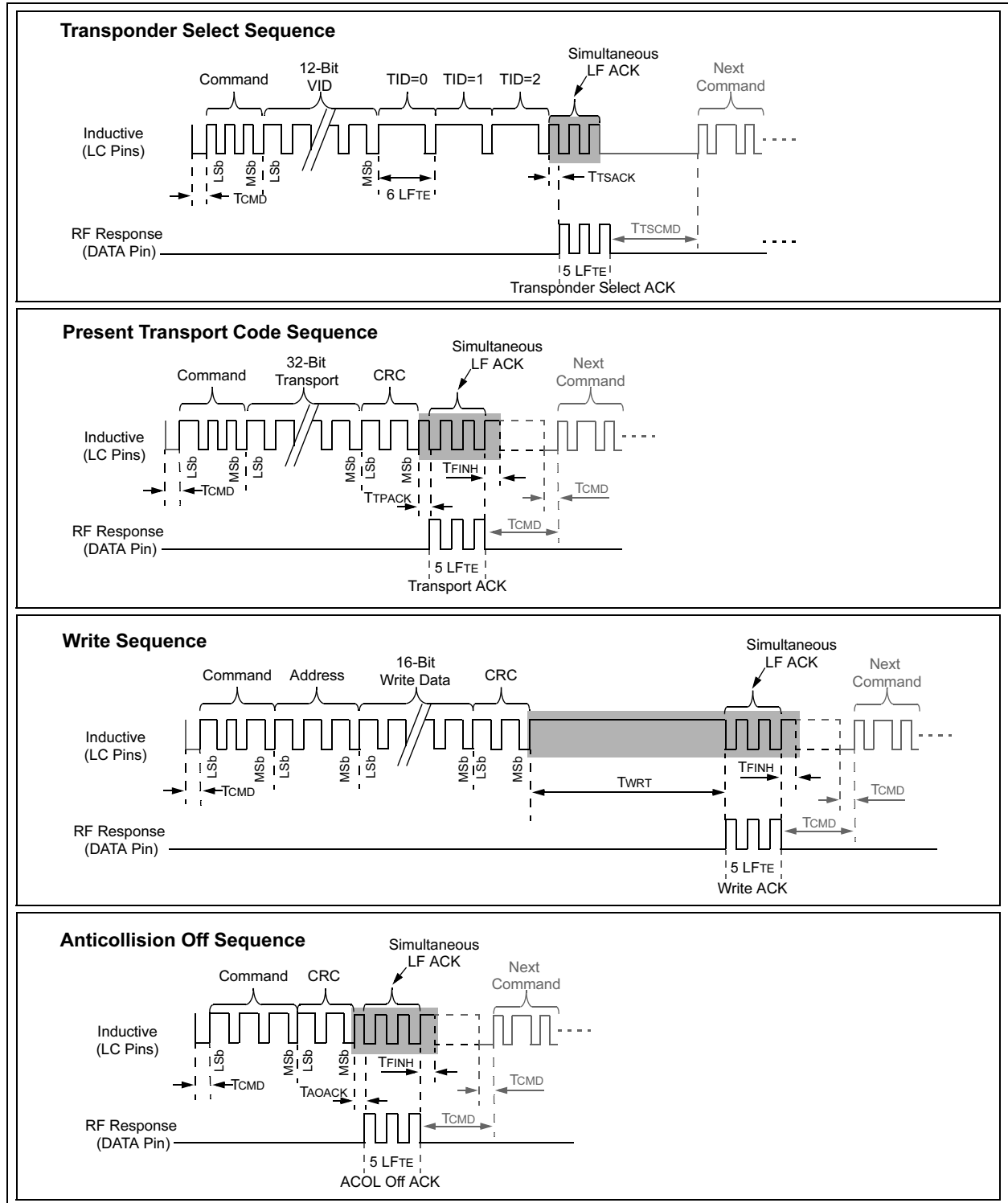

FIGURE 3-20: LF DATA RESPONSE ADJUSTMENTS (LFRSP=1)

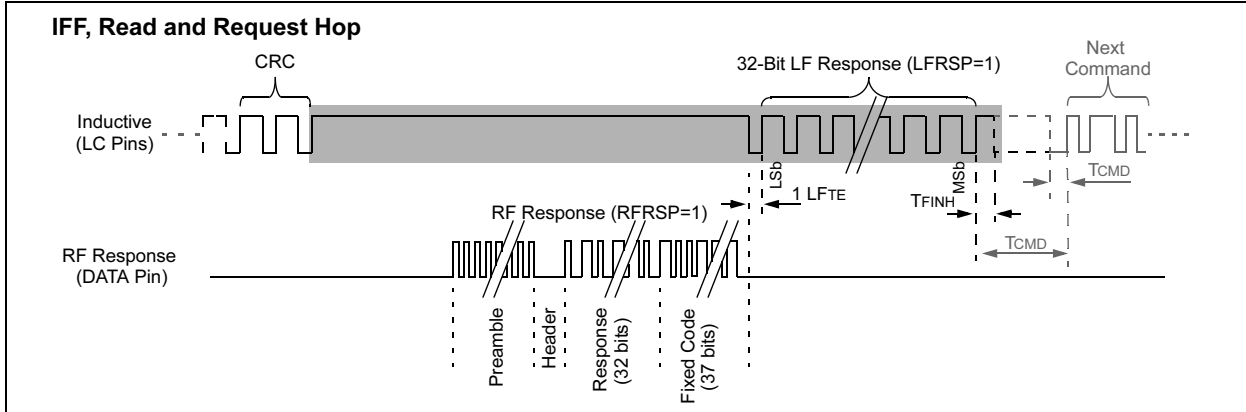
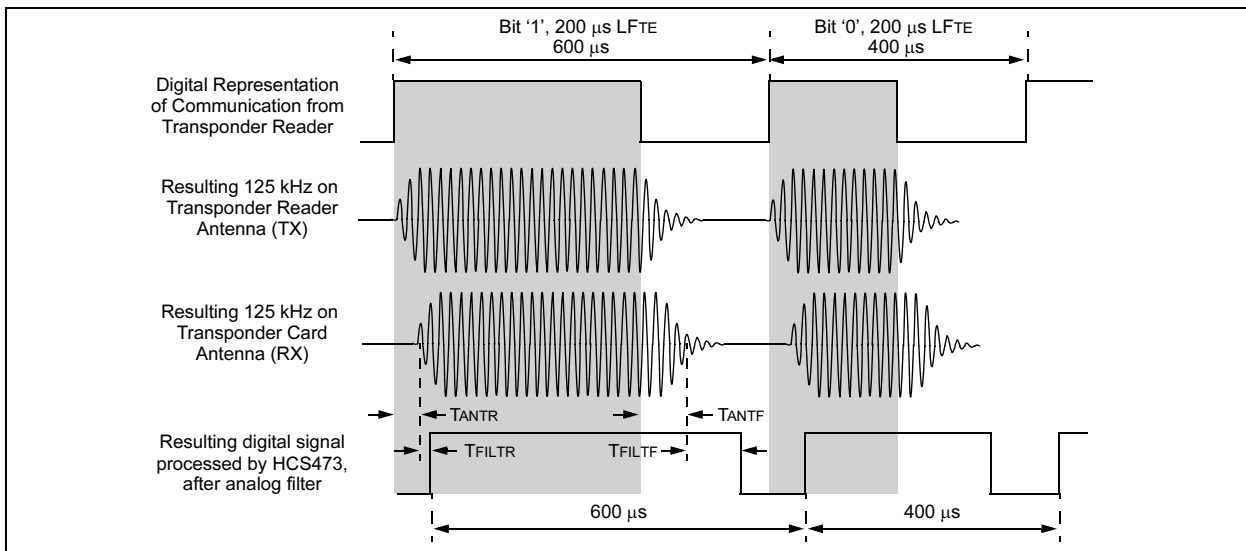

FIGURE 3-21: LF COMMUNICATION ANALOG DELAYS



3.2.7 RECEIVE STABILITY - CALCULATING COMMUNICATION T_E

The HCS473's internal oscillator may vary $\pm 10\%$ over the device's rated voltage and temperature range for commercial temperature devices. A certain percentage of industrial temperature devices vary further on the slow side, -20% , when used at higher voltages ($V_{DD} > 3.5V$) and cold temperature. When the internal oscillator varies, both its transmitted T_E and expected T_E when receiving will vary.

The HCS473 receive capability is ensured over a $\pm 10\%$ oscillator variance, with receive capability no longer robust as oscillator variance approaches $\pm 15\%$. Industrial devices operating at V_{DD} voltages greater than 3.5V (and cold temperature) are therefore not guaranteed to be able to properly receive when communicated to using an exact T_E . When designing for these specific operating conditions, the system designer must implement a method to adjust communication timing to the speed of the HCS473.

Communication reliability with the transponder may be improved by the transponder reader calculating the HCS473's T_E from the Field Acknowledge sequence and using this exact time element in communication to and in reception routines from the transponder.

Always begin and end the time measurement on rising edges. Whether LF or RF, the falling edge decay rates may vary but the rising edge relationships should remain consistent. A common T_E calculation method would be to time an $8T_E$ sequence from the first Field Acknowledge, then divide the value down to determine the single T_E value. An $8T_E$ measurement will give good resolution and may be easily right-shifted (divide by 2) three times for the math portion of the calculation (Figure 3-22).

FIGURE 3-22: Calculating Communication Te

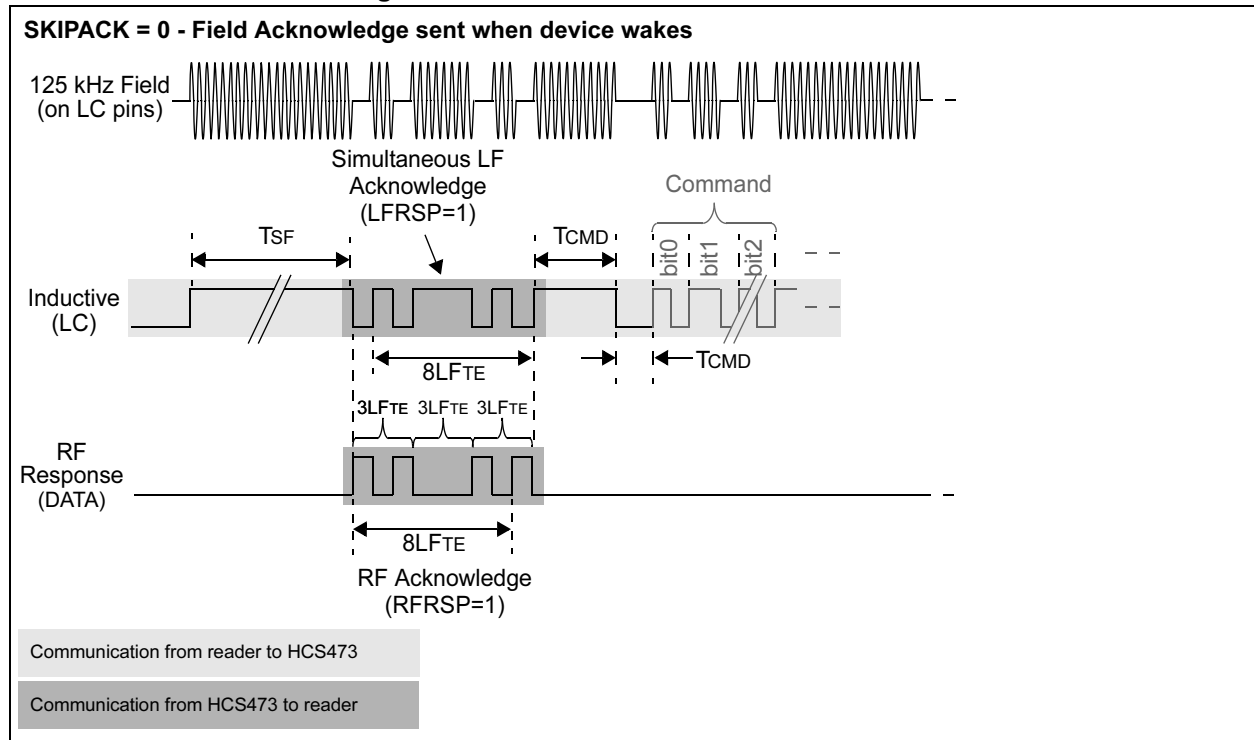

3.2.8 RFEN DURING LF COMMUNICATION (Figure 3-23)

3.2.8.1 Wake-up Sequence

The wake-up Acknowledge sequence has the shortest, but fixed, PLL setup time, 1LFTE.

3.2.8.2 Transponder Select Sequence

PLL setup occurs on the rising edge of the first VID bit in anticipation of the TID Acknowledge. The setup time before the ACK begins is therefore a function of...

- LF baud rate
- VID value
- TID value

3.2.8.3 ACK Response Sequences Concluding with CRC

Command sequences ending with CRC bits and expecting an Acknowledge response have a similar PLL setup sequence. This includes "Present Transport Code", "Write" and "Anticollision Off".

PLL setup occurs on the rising edge of the first CRC bit in anticipation of the Acknowledge. The setup time is therefore a function of...

- LF baud rate
- CRC value
- Response time: TPACK, TWRT, TAOACK.

3.2.8.4 Data Response Sequences Concluding with CRC

Command sequences ending with CRC bits and expecting data response (code hopping word) have a similar PLL setup sequence. This includes "IFF", "Read" and "Request Hopping Code".

PLL setup occurs on the rising edge of the first CRC bit in anticipation of the data transmission. The setup time is therefore a function of...

- LF baud rate
- CRC value
- Response time: TUFF, TREAD, THOP.

FIGURE 3-23: RFEN BEHAVIOR DURING LF COMMUNICATION

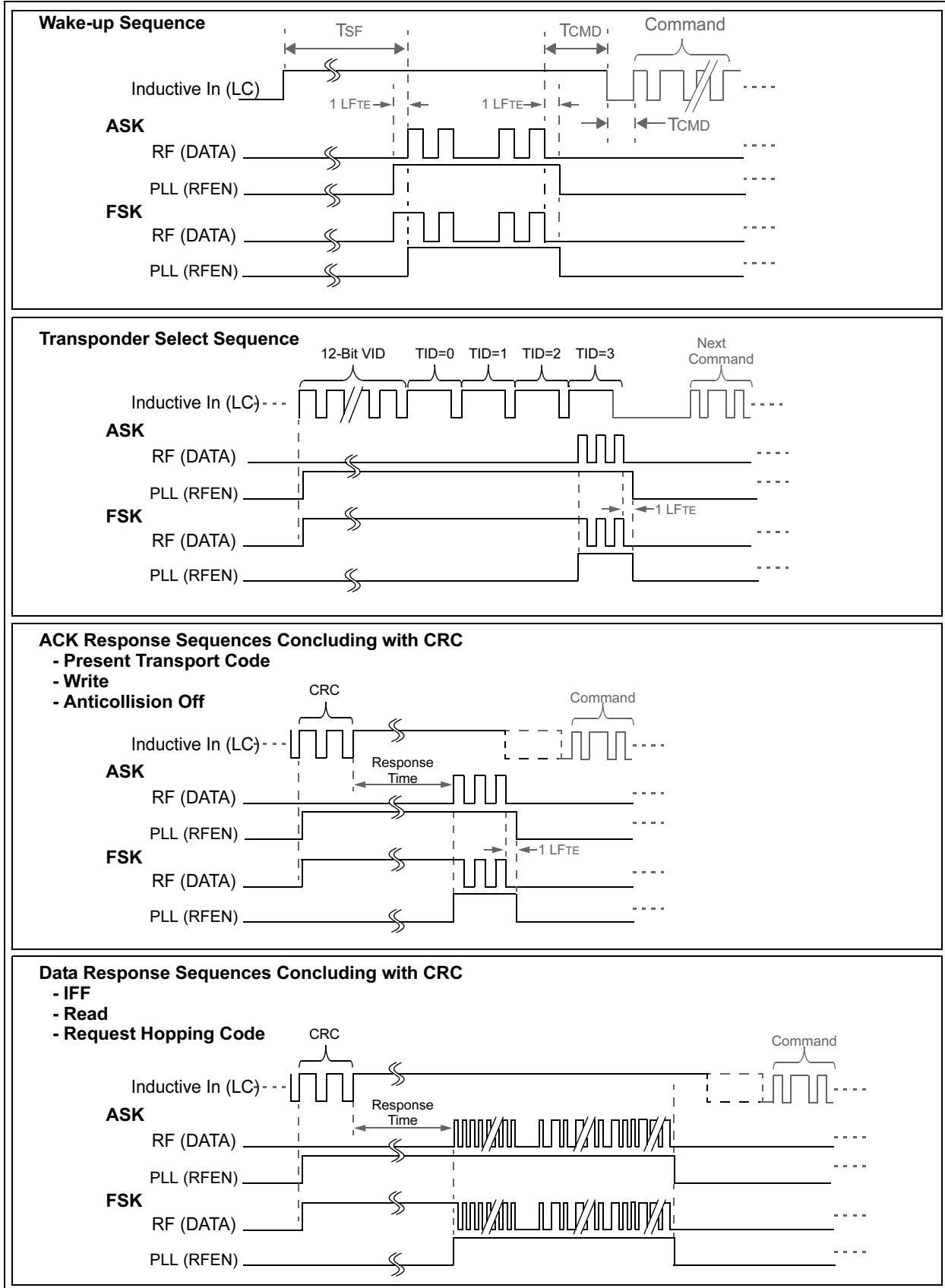

3.3 CONFIGURATION SUMMARY

TABLE 3-6: CONFIGURATION SUMMARY

Symbol	Address: Bits	Description ⁽¹⁾			Reference Section
USR 0	00: 16 bits	User EEPROM Area			3.2.3.4, 3.2.3.5
USR 1	02: 16 bits	User EEPROM Area			
USR 2	04: 16 bits	User EEPROM Area			
USR 3	06: 16 bits	User EEPROM Area			
SER	08: 32 bits	Encoder Serial Number			
DEVID 1	0C: 16 bits	Device Identifier #1 - Vehicle/Token ID Number #1			3.2.1.4
DEVID 2	0E: 16 bits	Device Identifier #2 - Vehicle/Token ID Number #2			
IFF KEY	10: 64 bits	IFF Key			3.2.3.3
COUNT	18: 64 bits	Encoder Synchronization Counter and Checksum			1.2.3
KEY	20: 64 bits	Encoder Key			
SEED	28: 60 bits	Encoder Seed Value			3.1.2.2
TCODE	30: 32 bits	Transport Code			3.2.3.2
DISC	34: 10 bits	Encoder Discrimination Value			3.1.8
RFEN	36: 7 - - - - -	RF Enable Pin	0 - S3	1 - RF Enable	3.1.4.8
PLLSEL	36: - 6 - - - - -	PLL Interface Select	0 - ASK	1 - FSK	3.1.4.7
VLOWSEL	36: - - 5 - - - - -	Low Voltage Trip Point Select ⁽²⁾	0 - 2.2V	1 - 3.3V	3.1.4.6
CNTSEL	36: - - - 4 - - - -	Counter Select	0 - 16 bits	1 - 20 bits	3.1.4.5
QUEN	36: - - - - 3 - - -	Queue Counter Enable	0 - Disable	1 - Enable	3.1.4.4
XSER	36: - - - - - 2 - -	Extended Serial Number	0 - 28 bits	1 - 32 bits	3.1.4.3
HSEL	36: - - - - - 1 -	Header Select ⁽¹⁾	0 - 4 TE	1 - 10 TE	3.1.4.2
MSEL	36: - - - - - 0	Modulation Format	0 - PWM	1 - Manchester	3.1.4.1
SDMD	37: 7 - - - - -	Seed Mode	0 - User	1 - Production	3.1.4.12
SDLM	37: - 6 - - - - -	Limited Seed	0 - Unlimited	1 - Limited	3.1.4.11
SDTM	37: - - 5 4 - - - -	Time Before Seed code word ⁽¹⁾	<i>Value</i>	<i>Time (s)</i>	3.1.4.10
			00 ₂	0.0	
			01 ₂	0.8	
			10 ₂	1.6	
			11 ₂	3.2	
SDBT	37: - - - - 3 2 1 0	Seed Button Code	Bit order = S3-S2-S1-S0		3.1.4.9
TSEL	38: 7 6 - - - - -	Timeout Select ⁽¹⁾	<i>Value</i>	<i>Time (s)</i>	3.1.4.16
			00 ₂	4	
			01 ₂	8	
			10 ₂	16	
			11 ₂	32	
MTX	38: - - 5 4 - - - -	Minimum Code Words	<i>Value</i>	<i>Value</i>	3.1.4.15
			00 ₂	1	
			01 ₂	2	
			10 ₂	4	
			11 ₂	8	

HCS473

TABLE 3-6: CONFIGURATION SUMMARY

Symbol	Address: Bits	Description ⁽¹⁾			Reference Section
GSEL	38: - - - - 3 2 - -	Guard Time Select ⁽¹⁾	<i>Value</i>	<i>Time (ms)</i>	3.1.4.14
			00 ₂	0.0	
			01 ₂	6.4	
			10 ₂	51.2	
			11 ₂	102.4	
RFBSL	38: - - - - - 1 0	RF Transmission Baud Rate Select ⁽¹⁾	<i>Value</i>	<i>TE (μs)</i>	3.1.4.13
			00 ₂	100	
			01 ₂	200	
			10 ₂	400	
			11 ₂	800	
LFDEMOD	39: 7 - - - - -	LF Demodulator	0 - Normal	1 - Demod	3.2.1.2
TPLS	39: - - - - 3 - - -	Transponder Preamble Length	0 - Normal	1 - Short	3.2.1.1
PRD	39: - - - - - 2 - -	Preamble Duty Cycle ⁽¹⁾	0 - 33%	1 - 50%	3.1.4.19
LPRL	39: - - - - - 1 -	Long Preamble Length ⁽¹⁾	0 - 75ms	1 - 100ms	3.1.4.18
LPRE	39: - - - - - 0	Long Preamble Enable	0 - Disable	1 - Enable	3.1.4.17
SKIPACK	3A: 7 - - - - -	Skip First ACK	0 - Disable	1 - Enable	3.2.1.8
RFRSP	3A: - 6 - - - - -	RF Response	0 - Disable	1 - Enable	3.2.1.7
LCRSP	3A: - - 5 - - - - -	LC Response	0 - Disable	1 - Enable	3.2.1.7
DAMP	3A: - - - 4 - - - -	Intelligent LC Damping	0 - Disable	1 - Enable	3.2.1.6
PXMA	3A: - - - - 3 - - -	Proximity Activation	0 - Disable	1 - Enable	3.2.1.5
ACOL	3A: - - - - - 2 - -	Anticollision	0 - Disable	1 - Enable	3.2.1.4
LFBSL	3A: - - - - - 1 0	LF Transmission Baud Rate Select ⁽¹⁾	<i>Value</i>	<i>TE (μs)</i>	3.2.1.3
			00 ₂	100	
			01 ₂	200	
			10 ₂	400	
			11 ₂	800	
END	3F 01011010	Unused, always set = 5A			

Note 1: All Timing values vary ±10%. Industrial temperature devices operating at cold and 3.5V < VDD < 5.5V vary +10%, -20%.

2: Voltage thresholds should be ±250 mV for the low voltage range and ±400 mV for the high voltage range.

4.0 PROGRAMMING SPECIFICATION

The HCS473 programming specification is extensively covered in document DS41163 and will not be duplicated here.

HCS473

NOTES:

5.0 INTEGRATING THE HCS473 INTO A SYSTEM

Use of the HCS473 in a system requires a compatible decoder. This decoder is typically a microcontroller with a low frequency coil antenna and radio frequency receiver. Example firmware routines that accept and decrypt KEELOQ transmissions can be found in Application Notes and the KEELOQ license disk.

5.1 Training the Receiver

In order for a transmitter to be used with a decoder, the transmitter must first be 'learned'. When a decoder learns a transmitter, it is suggested that the decoder stores the serial number and current synchronization value in EEPROM. Some learning strategies have been patented and care must be taken not to infringe on them. The decoder must keep track of these values for every transmitter that is learned (see Figure 5-1).

The maximum number of transmitters that can be learned is limited only by the available EEPROM memory. The decoder must also store the manufacturer's code in order to learn a transmitter. This value will not change in a typical system, so it is usually stored as part of the microcontroller ROM code. Storing the manufacturer's code as part of the ROM code improves security by keeping it off the external bus to the EEPROM.

FIGURE 5-1: TYPICAL LEARN SEQUENCE

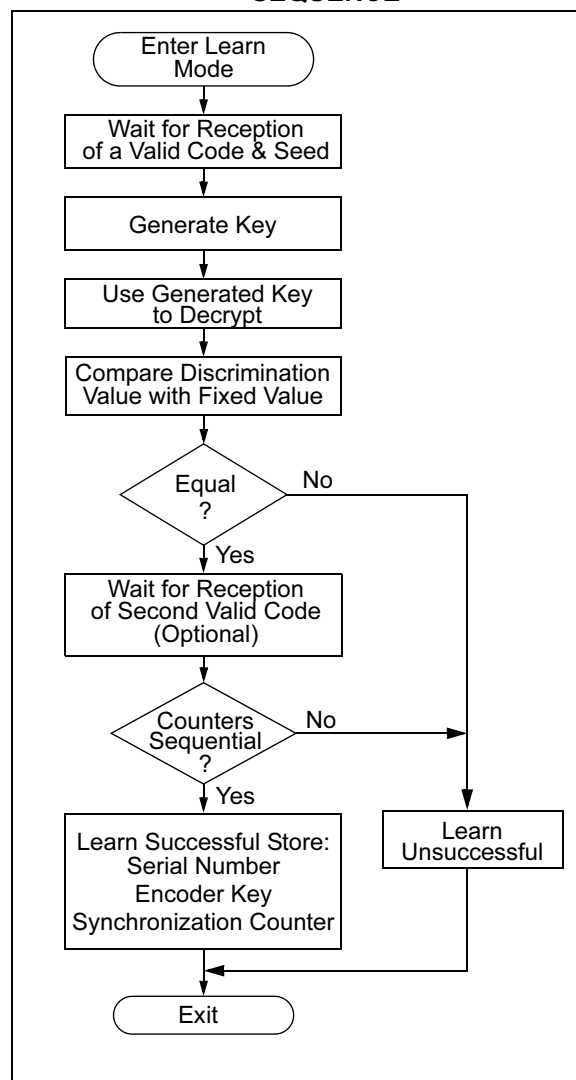

5.2 Decoder Operation

In a typical decoder operation (Figure 5-2), the key generation on the decoder side is performed by taking the serial number from a transmission and combining that with the manufacturer's code to create the same secret key that was used by the transmitter. Once the secret key is obtained, the rest of the transmission can be decrypted. The decoder waits for a transmission and immediately can check the serial number to determine if it is a learned transmitter. If it is, the encrypted portion of the transmission is decrypted using the stored key. It uses the discrimination bits to determine if the decryption was valid. If everything up to this point is valid, the synchronization value is evaluated.

FIGURE 5-2: TYPICAL DECODER OPERATION

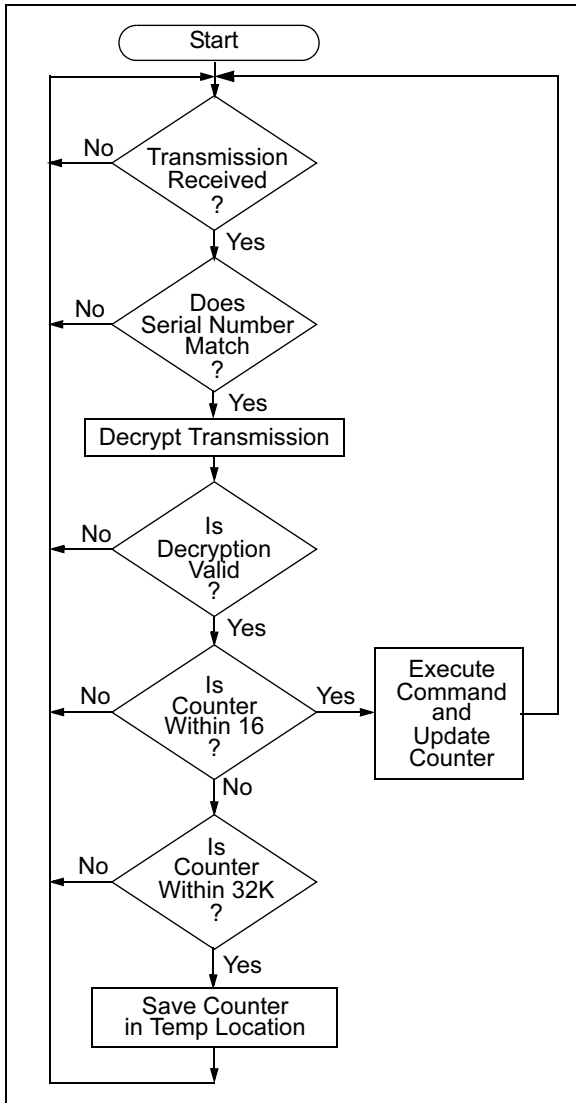

5.3 Synchronization with Decoder

The technology features a sophisticated synchronization technique (Figure 5-3) which does not require the calculation and storage of future codes. If the stored counter value for that particular transmitter and the counter value that was just decrypted are within a window of 16 codes, the counter is stored and the command is executed. If the counter value was not within the single operation window, but is within the double operation window of 32K codes (when using a 16-bit counter), the transmitted synchronization value is stored in temporary location and it goes back to waiting for another transmission.

When the next valid transmission is received, it will check the new value with the one in temporary storage. If the two values are sequential, it is assumed that the

counter had just gotten out of the single operation 'window'. Since it is now back in sync, the new synchronization value is stored and the command executed.

If a transmitter has somehow gotten out of the double operation window, the transmitter will not work and must be relearned. Since the entire window rotates after each valid transmission, codes that have been used are part of the 'blocked' (32K) codes and are no longer valid. This eliminates the possibility of grabbing a previous code and retransmitting to gain entry.

Note: The synchronization method described in this section is only a typical implementation and because it is usually implemented in firmware, it can be altered to fit the needs of a particular system

FIGURE 5-3: SYNCHRONIZATION WINDOW (16-BIT COUNTER)

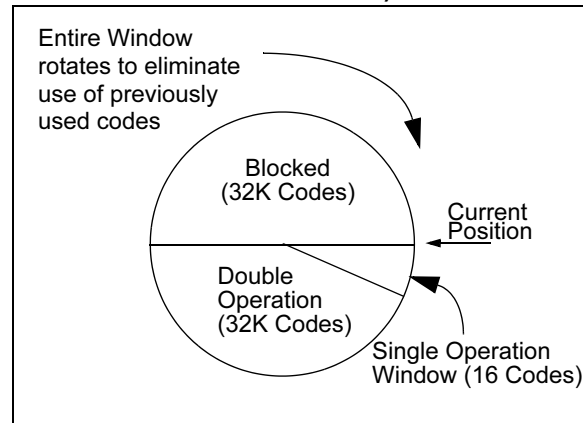

5.4 Inductive Communication

Communication between a base station and a HCS473 transponder occurs via magnetic coupling between the transponder coil and base station coil. The base station coil forms part of a series RLC circuit. The base station communicates to the transponder by switching the 125 kHz signal to the series RLC circuit on and off. Thus, the base station magnetic field is switched on and off. The transponder coil is connected in parallel with a resonating capacitor (125 kHz) and the HCS473.

When the transponder is brought into the base station magnetic field, it magnetically couples with this field and draws energy from it. This loading effect can be observed as a decrease in voltage across the base station resonating capacitor. The KEELQ transponder communicates to the base station by "shorting out" its parallel LC circuit. This detunes the transponder and removes the load, which is observed as an increase in voltage across the base station resonating capacitor. The base station capacitor voltage is the input to the base station AM demodulator circuit. The demodulator extracts the transponder data for further processing by the base station software.

5.5 Transponder Design

You must initially decide if a ferrite core or an air core antenna will be used. There are advantages and disadvantages to using each. One advantage of using a ferrite core is that the coil can have a larger inductance for a given volume. Volume will usually be the primary constraint as it will need to fit into a:

- key fob
- credit card
- other small package.

First step: choose the transponder coil external dimensions because packaging places large constraints on antenna design.

Second step: properties of the core, coil windings, as well as the equivalent load placed across the coil must be determined. Calculations from the first two steps will fix the initial coil specification. The initial coil specification includes:

- Minimum number of wire turns on the coil
- Wire diameter
- Wire resistance
- Coil inductance
- Required resonating capacitor.

Note: The exact number of turns may be tweaked such that a standard value resonant capacitor may be used.

Build the initial coil and take appropriate measurements to determine the coil quality factor. The data gathered to this point may then be used to calculate an Optimum Coil Specification.

It is not this data sheet's purpose to present in-depth details regarding LC antennae and their tuning. Please refer to "Low Frequency Magnetic Transmitter Design Application Note", AN232, for appropriate LF antenna design details.

Note: Microchip also has a confidential Application Note on Magnetic Sensors (AN832C). Contact Microchip for a Non-Disclosure Agreement in order to obtain this application note.

5.6 Security Considerations

The strength of this security is based on keeping a secret inside the transmitter that can be verified by encrypted transmissions to a trained receiver. The transmitter's secret is the manufacturer's key, not the encryption algorithm. If that key is compromised, then a smart transceiver can:

- capture any serial number
- create a valid code word
- trick all receivers trained with that serial number.

The key cannot be read from the EEPROM without costly die probing, but it can be calculated by brute force decryption attacks on transmitted code words. The cost for these attacks should exceed what you would want to protect.

To protect the security of other receivers with the same manufacturer's code, you need to use the random seed for secure learn. It is a second secret that is unique for each transmitter. It's transmission on a special button press combination can be disabled if the receiver has another way to find it, or is limited to the first 127 transmissions for the receiver to learn it. This way it is very unlikely to ever be captured. Now if a manufacturer's key is compromised, new transmitters can be created. But without the unique seed, they must be relearned by the receiver. In the same way, if the transmissions are decrypted by brute force on a computer, the random seed hides the manufacturer's key and prevents more than one transmitter from being compromised.

The length of the code word at these baud rates makes brute force attacks that guess the hopping code require years to perform. To make the receiver less susceptible to this attack, make sure that you test all the bits in the decrypted code for the correct value. Do not just test low counter bits for sync and the bit for the button input of interest.

The main benefit of hopping codes is to prevent the retransmission of captured code words. This works very well for code words that the receiver decodes. Its weakness is if a code is captured when the receiver misses it, the code may trick the receiver once if it is used before the next valid transmission. To make the receiver more secure it could increment the counter on questionable code word receptions. To make the transmitter more secure it could use separate buttons for lock and unlock functions. Another way would be to require two different buttons in sequence to gain access.

There are other ways to make KEELOQ systems more secure, but these are all trade-offs. You need to find a balance between:

- Security
- Design effort
- Usability (particularly in failure modes).

For example, if a button sticks or someone plays with it, the counter should not end up in the blocked code window, rendering the transmitter useless or requiring the receiver to relearn the transmitter.

HCS473

NOTES:

6.0 DEVELOPMENT SUPPORT

The PICmicro[®] microcontrollers are supported with a full range of hardware and software development tools:

- Integrated Development Environment
 - MPLAB[®] IDE Software
- Assemblers/Compilers/Linkers
 - MPASM[™] Assembler
 - MPLAB C17 and MPLAB C18 C Compilers
 - MPLINK[™] Object Linker/
MPLIB[™] Object Librarian
- Simulators
 - MPLAB SIM Software Simulator
- Emulators
 - MPLAB ICE 2000 In-Circuit Emulator
 - ICEPIC[™] In-Circuit Emulator
- In-Circuit Debugger
 - MPLAB ICD
- Device Programmers
 - PRO MATE[®] II Universal Device Programmer
 - PICSTART[®] Plus Entry-Level Development Programmer
- Low Cost Demonstration Boards
 - PICDEM[™] 1 Demonstration Board
 - PICDEM 2 Demonstration Board
 - PICDEM 3 Demonstration Board
 - PICDEM 17 Demonstration Board
 - KEELOQ[®] Demonstration Board

6.1 MPLAB Integrated Development Environment Software

The MPLAB IDE software brings an ease of software development previously unseen in the 8-bit microcontroller market. The MPLAB IDE is a Windows[®]-based application that contains:

- An interface to debugging tools
 - simulator
 - programmer (sold separately)
 - emulator (sold separately)
 - in-circuit debugger (sold separately)
- A full-featured editor
- A project manager
- Customizable toolbar and key mapping
- A status bar
- On-line help

The MPLAB IDE allows you to:

- Edit your source files (either assembly or 'C')
- One touch assemble (or compile) and download to PICmicro emulator and simulator tools (automatically updates all project information)
- Debug using:
 - source files
 - absolute listing file
 - machine code

The ability to use MPLAB IDE with multiple debugging tools allows users to easily switch from the cost-effective simulator to a full-featured emulator with minimal retraining.

6.2 MPASM Assembler

The MPASM assembler is a full-featured universal macro assembler for all PICmicro MCU's.

The MPASM assembler has a command line interface and a Windows shell. It can be used as a stand-alone application on a Windows 3.x or greater system, or it can be used through MPLAB IDE. The MPASM assembler generates relocatable object files for the MPLINK object linker, Intel[®] standard HEX files, MAP files to detail memory usage and symbol reference, an absolute LST file that contains source lines and generated machine code, and a COD file for debugging.

The MPASM assembler features include:

- Integration into MPLAB IDE projects.
- User-defined macros to streamline assembly code.
- Conditional assembly for multi-purpose source files.
- Directives that allow complete control over the assembly process.

6.3 MPLAB C17 and MPLAB C18 C Compilers

The MPLAB C17 and MPLAB C18 Code Development Systems are complete ANSI 'C' compilers for Microchip's PIC17CXXX and PIC18CXXX family of microcontrollers, respectively. These compilers provide powerful integration capabilities and ease of use not found with other compilers.

For easier source level debugging, the compilers provide symbol information that is compatible with the MPLAB IDE memory display.

6.4 MPLINK Object Linker/ MPLIB Object Librarian

The MPLINK object linker combines relocatable objects created by the MPASM assembler and the MPLAB C17 and MPLAB C18 C compilers. It can also link relocatable objects from pre-compiled libraries, using directives from a linker script.

The MPLIB object librarian is a librarian for pre-compiled code to be used with the MPLINK object linker. When a routine from a library is called from another source file, only the modules that contain that routine will be linked in with the application. This allows large libraries to be used efficiently in many different applications. The MPLIB object librarian manages the creation and modification of library files.

The MPLINK object linker features include:

- Integration with MPASM assembler and MPLAB C17 and MPLAB C18 C compilers.
- Allows all memory areas to be defined as sections to provide link-time flexibility.

The MPLIB object librarian features include:

- Easier linking because single libraries can be included instead of many smaller files.
- Helps keep code maintainable by grouping related modules together.
- Allows libraries to be created and modules to be added, listed, replaced, deleted or extracted.

6.5 MPLAB SIM Software Simulator

The MPLAB SIM software simulator allows code development in a PC-hosted environment by simulating the PICmicro series microcontrollers on an instruction level. On any given instruction, the data areas can be examined or modified and stimuli can be applied from a file, or user-defined key press, to any of the pins. The execution can be performed in single step, execute until break, or Trace mode.

The MPLAB SIM simulator fully supports symbolic debugging using the MPLAB C17 and the MPLAB C18 C compilers and the MPASM assembler. The software simulator offers the flexibility to develop and debug code outside of the laboratory environment, making it an excellent multi-project software development tool.

6.6 MPLAB ICE High Performance Universal In-Circuit Emulator with MPLAB IDE

The MPLAB ICE universal in-circuit emulator is intended to provide the product development engineer with a complete microcontroller design tool set for PICmicro microcontrollers (MCUs). Software control of the MPLAB ICE in-circuit emulator is provided by the MPLAB Integrated Development Environment (IDE), which allows editing, building, downloading and source debugging from a single environment.

The MPLAB ICE 2000 is a full-featured emulator system with enhanced trace, trigger and data monitoring features. Interchangeable processor modules allow the system to be easily reconfigured for emulation of different processors. The universal architecture of the MPLAB ICE in-circuit emulator allows expansion to support new PICmicro microcontrollers.

The MPLAB ICE in-circuit emulator system has been designed as a real-time emulation system, with advanced features that are generally found on more expensive development tools. The PC platform and Microsoft® Windows environment were chosen to best make these features available to you, the end user.

6.7 ICEPIC In-Circuit Emulator

The ICEPIC low cost, in-circuit emulator is a solution for the Microchip Technology PIC16C5X, PIC16C6X, PIC16C7X and PIC16CXXX families of 8-bit One-Time-Programmable (OTP) microcontrollers. The modular system can support different subsets of PIC16C5X or PIC16CXXX products through the use of interchangeable personality modules, or daughter boards. The emulator is capable of emulating without target application circuitry being present.

6.8 MPLAB ICD In-Circuit Debugger

Microchip's In-Circuit Debugger, MPLAB ICD, is a powerful, low cost, run-time development tool. This tool is based on the FLASH PICmicro MCUs and can be used to develop for this and other PICmicro microcontrollers. The MPLAB ICD utilizes the in-circuit debugging capability built into the FLASH devices. This feature, along with Microchip's In-Circuit Serial Programming™ protocol, offers cost-effective in-circuit FLASH debugging from the graphical user interface of the MPLAB Integrated Development Environment. This enables a designer to develop and debug source code by watching variables, single-stepping and setting break points. Running at full speed enables testing hardware in real-time.

6.9 PRO MATE II Universal Device Programmer

The PRO MATE II universal device programmer is a full-featured programmer, capable of operating in Stand-alone mode, as well as PC-hosted mode. The PRO MATE II device programmer is CE compliant.

The PRO MATE II device programmer has programmable VDD and VPP supplies, which allow it to verify programmed memory at VDD min and VDD max for maximum reliability. It has an LCD display for instructions and error messages, keys to enter commands and a modular detachable socket assembly to support various package types. In Stand-alone mode, the PRO MATE II device programmer can read, verify, or program PICmicro devices. It can also set code protection in this mode.

6.10 PICSTART Plus Entry Level Development Programmer

The PICSTART Plus development programmer is an easy-to-use, low cost, prototype programmer. It connects to the PC via a COM (RS-232) port. MPLAB Integrated Development Environment software makes using the programmer simple and efficient.

The PICSTART Plus development programmer supports all PICmicro devices with up to 40 pins. Larger pin count devices, such as the PIC16C92X and PIC17C76X, may be supported with an adapter socket. The PICSTART Plus development programmer is CE compliant.

6.11 PICDEM 1 Low Cost PICmicro Demonstration Board

The PICDEM 1 demonstration board is a simple board which demonstrates the capabilities of several of Microchip's microcontrollers. The microcontrollers supported are: PIC16C5X (PIC16C54 to PIC16C58A), PIC16C61, PIC16C62X, PIC16C71, PIC16C8X, PIC17C42, PIC17C43 and PIC17C44. All necessary hardware and software is included to run basic demo programs. The user can program the sample microcontrollers provided with the PICDEM 1 demonstration board on a PRO MATE II device programmer, or a PICSTART Plus development programmer, and easily test firmware. The user can also connect the PICDEM 1 demonstration board to the MPLAB ICE in-circuit emulator and download the firmware to the emulator for testing. A prototype area is available for the user to build some additional hardware and connect it to the microcontroller socket(s). Some of the features include an RS-232 interface, a potentiometer for simulated analog input, push button switches and eight LEDs connected to PORTB.

6.12 PICDEM 2 Low Cost PIC16CXX Demonstration Board

The PICDEM 2 demonstration board is a simple demonstration board that supports the PIC16C62, PIC16C64, PIC16C65, PIC16C73 and PIC16C74 microcontrollers. All the necessary hardware and software is included to run the basic demonstration programs. The user can program the sample microcontrollers provided with the PICDEM 2 demonstration board on a PRO MATE II device programmer, or a PICSTART Plus development programmer, and easily test firmware. The MPLAB ICE in-circuit emulator may also be used with the PICDEM 2 demonstration board to test firmware. A prototype area has been provided to the user for adding additional hardware and connecting it to the microcontroller socket(s). Some of the features include a RS-232 interface, push button switches, a potentiometer for simulated analog input, a serial EEPROM to demonstrate usage of the I²C™ bus and separate headers for connection to an LCD module and a keypad.

6.13 PICDEM 3 Low Cost PIC16CXXX Demonstration Board

The PICDEM 3 demonstration board is a simple demonstration board that supports the PIC16C923 and PIC16C924 in the PLCC package. It will also support future 44-pin PLCC microcontrollers with an LCD Module. All the necessary hardware and software is included to run the basic demonstration programs. The user can program the sample microcontrollers provided with the PICDEM 3 demonstration board on a PRO MATE II device programmer, or a PICSTART Plus development programmer with an adapter socket, and easily test firmware. The MPLAB ICE in-circuit emulator may also be used with the PICDEM 3 demonstration board to test firmware. A prototype area has been provided to the user for adding hardware and connecting it to the microcontroller socket(s). Some of the features include a RS-232 interface, push button switches, a potentiometer for simulated analog input, a thermistor and separate headers for connection to an external LCD module and a keypad. Also provided on the PICDEM 3 demonstration board is a LCD panel, with 4 commons and 12 segments, that is capable of displaying time, temperature and day of the week. The PICDEM 3 demonstration board provides an additional RS-232 interface and Windows software for showing the demultiplexed LCD signals on a PC. A simple serial interface allows the user to construct a hardware demultiplexer for the LCD signals.

6.14 PICDEM 17 Demonstration Board

The PICDEM 17 demonstration board is an evaluation board that demonstrates the capabilities of several Microchip microcontrollers, including PIC17C752, PIC17C756A, PIC17C762 and PIC17C766. All necessary hardware is included to run basic demo programs, which are supplied on a 3.5-inch disk. A programmed sample is included and the user may erase it and program it with the other sample programs using the PRO MATE II device programmer, or the PICSTART Plus development programmer, and easily debug and test the sample code. In addition, the PICDEM 17 demonstration board supports downloading of programs to and executing out of external FLASH memory on board. The PICDEM 17 demonstration board is also usable with the MPLAB ICE in-circuit emulator, or the PICMASTER emulator and all of the sample programs can be run and modified using either emulator. Additionally, a generous prototype area is available for user hardware.

6.15 KEELOQ Evaluation and Programming Tools

KEELOQ evaluation and programming tools support Microchip's HCS Secure Data Products. The HCS evaluation kit includes a LCD display to show changing codes, a decoder to decode transmissions and a programming interface to program test transmitters.

TABLE 6-1: DEVELOPMENT TOOLS FROM MICROCHIP

Tool	PIC12CXX	PIC14000	PIC16C5X	PIC16C6X	PIC16CXX	PIC16C7X	PIC16C7XX	PIC16C8X	PIC16F8XX	PIC16G9XX	PIC17C4X	PIC17C7XX	PIC18CXX2	PIC18FXX	24CXX/ 25CXX/ 93CXX	HCSXX	MCRFXX	MCP2510
Software Tools																		
MPLAB® Integrated Development Environment	✓	✓	✓	✓	✓	✓	✓	✓	✓	✓	✓	✓	✓	✓	✓	✓	✓	✓
MPLAB® C17 C Compiler																		
MPLAB® C18 C Compiler																		
MPASM™ Assembler/ MPLINK™ Object Linker	✓	✓	✓	✓	✓	✓	✓	✓	✓	✓	✓	✓	✓	✓	✓	✓	✓	✓
MPLAB® ICE In-Circuit Emulator	✓	✓	✓	✓	✓	✓	✓	✓	✓	✓	✓	✓	✓	✓	✓	✓	✓	✓
ICEPIC™ In-Circuit Emulator	✓		✓	✓	✓	✓	✓	✓	✓	✓	✓	✓	✓	✓	✓	✓	✓	✓
Debugger																		
MPLAB® ICD In-Circuit Debugger				✓*					✓									
Programmers																		
PICSTART® Plus Entry Level Development Programmer	✓	✓	✓	✓	✓	✓	✓	✓	✓	✓	✓	✓	✓	✓	✓	✓	✓	✓
PRO MATE® II Universal Device Programmer	✓	✓	✓	✓	✓	✓	✓	✓	✓	✓	✓	✓	✓	✓	✓	✓	✓	✓
Demo Boards and Eval Kits																		
PICDEM™ 1 Demonstration Board			✓								✓							
PICDEM™ 2 Demonstration Board				✓†									✓					
PICDEM™ 3 Demonstration Board										✓								
PICDEM™ 14A Demonstration Board		✓																
PICDEM™ 17 Demonstration Board											✓							
KEELOQ® Evaluation Kit																✓		
KEELOQ® Transponder Kit																✓		
microID™ Programmer's Kit																	✓	
125 kHz microID™ Developer's Kit																	✓	
125 kHz Anticollision microID™ Developer's Kit																	✓	
13.56 MHz Anticollision microID™ Developer's Kit																	✓	
MCP2510 CAN Developer's Kit																	✓	✓

* Contact the Microchip Technology Inc. web site at www.microchip.com for information on how to use the MPLAB® ICD In-Circuit Debugger (DV164001) with PIC16C62, 63, 64, 65, 72, 73, 74, 76, 77.
 ** Contact Microchip Technology Inc. for availability date.
 † Development tool is available on select devices.

HCS473

NOTES:

7.0 ELECTRICAL CHARACTERISTICS

7.1 Absolute Maximum Ratings †

Ambient temperature under bias.....	-40°C to +125°C
Storage temperature	-65°C to +150°C
Voltage on \overline{VDD} w/respect to V_{SS}	-0.3V to +7.5V
Voltage on \overline{LED} w/respect to V_{SS}	-0.3V to +11V
Voltage on all other pins w/respect to V_{SS}	-0.3V to $V_{DD}+0.3V$
Total power dissipation ⁽¹⁾	500 mW
Maximum current out of V_{SS} pin	100 mA
Maximum current into V_{DD} pin	100 mA
Input clamp current, I_{IK} ($V_I < 0$ or $V_I > V_{DD}$).....	± 20 mA
Output clamp current, I_{OK} ($V_O < 0$ or $V_O > V_{DD}$).....	± 20 mA
Maximum output current sunk by any Output pin.....	25 mA
Maximum output current sourced by any Output pin	25 mA

Note 1: Power dissipation is calculated as follows: $P_{DIS} = V_{DD} \times \{I_{DD} - \hat{A} I_{OH}\} + \hat{A} \{(V_{DD} - V_{OH}) \times I_{OH}\} + \hat{A} (V_{OL} \times I_{OL})$.

† NOTICE: Stresses above those listed under “Absolute Maximum Ratings” may cause permanent damage to the device. This is a stress rating only and functional operation of the device at those or any other conditions above those indicated in the operation listings of this specification is not implied. Exposure to maximum rating conditions for extended periods may affect device reliability.

HCS473

TABLE 7-1: DC CHARACTERISTICS: HCS473

DC Characteristics All pins except power supply pins			Standard Operating Conditions (unless otherwise stated) Operating Temperature 0°C ≤ TA ≤ +70°C (Commercial) -20°C ≤ TA ≤ +85°C (Industrial)				
Param No.	Sym	Characteristic	Min	Typ†	Max	Units	Conditions
D001	VDD	Supply Voltage	2.05 ⁽²⁾	—	5.5	V	
D003	VPOR	VDD Start Voltage to ensure internal Power-on Reset signal	—	VSS	—	V	Cold RESET
D004	SVDD	VDD Rise Rate to ensure internal Power-on Reset signal	0.05*	—	—	V/ms	
D005	VBOR	Brown-out Reset Voltage	—	1.9	2	V	
	IDD	Supply Current⁽²⁾					
D010			—	1.0	5	mA	FOSC = 4 MHz, VDD = 5.5V ⁽³⁾
D010B			—	—	2.0	mA	FOSC = 4 MHz, VDD = 3.5V ⁽³⁾
D021A	ISS	Shutdown Current	—	0.1	1.0	μA	VDD = 5.5V
	ΔIDD	Transponder Current					
D022			—	4.2	8	μA	VDD = VDDT = 5.5V, no LC signals
D022A				3.5	6	μA	VDD = VDDT = 3.0V, no LC signals
				7.5	25	μA	VDD = VDDT = 3V, Active LC signals
	VIL	Input Low Voltage					
D030		Input Pins					
D030A		With TTL Buffer	VSS	—	0.8	V	4.5V ≤ VDD ≤ 5.5V
			VSS	—	0.15V _D	V	Otherwise
D031		With Schmitt Trigger Buffer	VSS	—	0.2VDD	V	
	VIH	Input High Voltage					
D040		Input Pins					
D040A		With TTL Buffer	2.0 (0.25 VDD+0.8)	— —	VDD VDD	V V	4.5V ≤ VDD ≤ 5.5V Otherwise
D041		With Schmitt Trigger Buffer	0.8 VDD	—	VDD	V	
	VTOL	Input Threshold Voltage					
D053		VLOW detect tolerance	—	—	±250	mV	VLOWSEL = 2.2V
			—	—	±400	mV	VLOWSEL = 3.3V
	IIL	Input Leakage Current					
D060		Input Pins	—	—	±1	μA	VSS ≤ VPIN ≤ VDD, Pin at Hi-impedance, no pull-downs enabled
D061		LED	—	—	±5	μA	VSS ≤ VPIN ≤ VDD
	VOL	Output Low Voltage					
D080		Output Pins	—	—	0.6	V	IOL = 8.5 mA, VDD = 4.5V
	VOH	Output High Voltage					
D090		Output Pins	VDD-0.7	—	—	V	IOH = -3.0 mA, VDD = 4.5V
D091		LED	1.5	—	—	V	IOH = -0.5 mA, VDD = 4.5V

TABLE 7-1: DC CHARACTERISTICS: HCS473 (CONTINUED)

DC Characteristics		Standard Operating Conditions (unless otherwise stated)					
All pins except power supply pins		Operating Temperature 0°C ≤ TA ≤ +70°C (Commercial) -20°C ≤ TA ≤ +85°C (Industrial)					
Param No.	Sym	Characteristic	Min	Typ†	Max	Units	Conditions
D100	RPD	Internal Pull-down Resistance					
		S0 - S3	40	75	100	KΩ	If enabled
D120	Ed	Data EEPROM Memory					
		Endurance	200K	1000K	—	E/W	25°C at 5V
D121	VDRW	VDD for Read/Write	2.05	—	5.5	V	
D122	TDEW	Erase/Write Cycle Time ⁽¹⁾	—	4	10	ms	

* These parameters are characterized but not tested.

† "Typ" column data is at 5.0V, 25°C unless otherwise stated. These parameters are for design guidance only and are not tested.

- Note 1:** The supply current is mainly a function of the operating voltage and frequency. Other factors such as I/O pin loading and switching rate, oscillator type, internal code execution pattern, and temperature also have an impact on the current consumption.
- 2:** Should operate down to VBOR but not tested below 2.0V.
- 3:** The test conditions for all IDD measurements in active Operation mode are: all I/O pins tristated, pulled to VDD. MCLR = VDD; WDT enabled/disabled as specified. The power-down/shutdown current in SLEEP mode does not depend on the oscillator frequency. Power-down current is measured with the part in SLEEP mode, with all I/O pins in hi-impedance state and tied to VDD or VSS. The Δ current is the additional current consumed when the WDT is enabled. This current should be added to the base IDD or IPD measurement.

TABLE 7-2: TRANSPONDER CHARACTERISTICS

DC Characteristics		Standard Operating Conditions (unless otherwise stated)				
All pins except power supply pins		Operating Temperature 0°C ≤ TA ≤ +70°C (Commercial) -20°C ≤ TA ≤ +85°C (Industrial)				
Symbol	Symbol	2.05V < VDD < 5.5V			Unit	Conditions
		Min	Typ ⁽¹⁾	Max		
V _{lcc}	LC input clamp voltage	—	10	—	V	ILC < 1mA
VDDTV	LC induced output voltage	—	3.5	—	V	10 V < VLCC, IDD = 2 mA
f _c	Carrier frequency	—	125	—	kHz	
VLCS	LC Input Sensitivity	—	15	30	mVRMS	VDD = 5.5V VDD = 3.0V
		—	18	35		
VLCC	LCCOM Output Voltage	—	600	—	mV	ILCCOM = 0 mA

Note: These parameters are characterized but not tested.

HCS473

TABLE 7-3: AC CHARACTERISTICS, Fosc = 4 MHz⁽¹⁾

AC Characteristics		Fosc = 4 MHz ⁽¹⁾ The min and max values below are due to HCS473 algorithm tolerances, not variations due to supply voltage and temperature.		
Symbol	Min	Typ	Max	Description
General HCS473 Timing				
TDB	—	10 ms	—	Debounce Time
TQUE	—	2s	—	Que Window
TPU	—	10.9 ms	—	Power-up Delay Time (includes button debounce)
TPLL	—	19 ms	—	Encoder Mode PLL activation to first code word
TLEDON	—	100 ms	—	LED ON Time
TLEDOFF	—	500 ms	—	LED OFF Time
Communication from Transponder Reader to HCS473				
TCMD	1LFTE+100 μs	—	10.2 ms	
TTSCMD	1LFTE+100 μs	—	10.2 ms	Delay from Transponder Select ACK to next command
TFINH	100 μs	1LFTE	—	Time to leave LF on after last data bit's rising edge
Response from HCS473 to Transponder Reader				
TSF	1ms+1LFTE	3.5ms+1LFTE	10ms+1LFTE	Delay to wake-up Acknowledge sequence
TTSACK	1LFTE+16 μs 1LFTE-11 μs	1LFTE+30 μs 1 LFTE	1LFTE+44 μs 1LFTE+11 μs	Delay from TID pulse rising edge to TID Acknowledge TID = 0 TID > 0
TTPACK	157 μs	179 μs	212 μs	Delay to Transport Code Acknowledge
TWRT	—	4 ms	10 ms	Delay to Write Acknowledge
TAOACK	67 μs	89 μs	122 μs	Delay to anticollision off Acknowledge
TIFF	—	5.64ms	—	Delay to IFF response - RF or LF response
TREAD	205 μs	227 μs	260 μs	Delay to read response - RF or LF response
THOP	—	19 ms	—	Delay to hopping code response - RF or LF response
TDAMP	—	1.2 LFTE	—	Delay from detecting LC rising edge to first damp pulse
TDEMOD	—	16.4 ms	—	Demodulator mode window looking for edge on LC pin
Timing Element Te				
TE	90 180 360 720	100 200 400 800	110 220 440 880	RFTE or LFTE RFBSL = LFBSL = 00 ₂ RFBSL = LFBSL = 01 ₂ RFBSL = LFBSL = 10 ₂ RFBSL = LFBSL = 11 ₂
Analog delays				
TFILTR	—	15 μs	—	HCS473 analog LF filter charge time
TFILTF	—	70 μs	—	HCS473 analog LF filter discharge time
TANTR	<i>Hardware design dependent</i>			Cumulative LF antenna delay when field is turned on
TANTF	<i>Hardware design dependent</i>			Cumulative LF antenna delay when field is turned off

- Note**
- 1: Fosc = 4 MHz may be centered at the designer's choice of supply voltage (VDD) and temperature.
 - 2: LFTE is based on the HCS473's timing, not the timing of the transponder reader. Therefore LFTE is subject to HCS473 oscillator variation.
 - 3: Response timing accounts for TFILTR but not for TANTR or TANTF, as they are design dependent. The system designer must compensate communication accordingly for TANTR and TANTF.
 - 4: Timing parameters are characterized but not tested.

TABLE 7-4: AC CHARACTERISTICS, Commercial Temperature Devices

AC Characteristics			T _{amb} = 0°C to 70°C, 2.05V < V _{DD} < 5.5V F _{OSC} = 4 MHz ±10%	
Symbol	Min	Typ ⁽¹⁾	Max	Description
General HCS473 Timing				
TDB	9 ms	10 ms	11 ms	Debounce Time
TQUE	1.8s	2s	2.2s	Que Window
TPU	9.81 ms	10.9 ms	12 ms	Power-up Delay Time (includes button debounce)
TPLL	17.1 ms	19 ms	20.9 ms	Encoder Mode PLL activation to first code word
TLEDON	90 ms	100 ms	110 ms	LED ON Time
TLEDOFF	450 ms	500 ms	550 ms	LED OFF Time
Communication from Transponder Reader to HCS473				
TCMD	1.1 LFTE+100 μs	—	9.18 ms	
TTSCMD	1.1 LFTE+100 μs	—	9.18 ms	Delay from Transponder Select ACK to next command
TFINH	100 μs	1 LFTE	—	Time to leave LF on after last data bit's rising edge
Response from HCS473 to Transponder Reader				
TSF	1 ms+.9 LFTE	3.5 ms+1 LFTE	10 ms+1. 1LFTE	Delay to wake-up Acknowledge sequence
TTSACK	.9 LFTE+14 μs .9 LFTE-12 μs	1 LFTE+30 μs 1 LFTE	1.1 LFTE+49 μs 1.1 LFTE+12 μs	Delay from TID pulse rising edge to TID acknowledge TID = 0 TID > 0
TTPACK	141 μs	179 μs	234 μs	Delay to Transport Code Acknowledge
TWRT	—	4 ms	10ms	Delay to Write Acknowledge
TAOACK	60 μs	89 μs	135 μs	Delay to anticollision off Acknowledge
TIFF	5.07 ms	5.64 ms	6.2 ms	Delay to IFF response - RF or LF response
TREAD	184 μs	227 μs	286 μs	Delay to read response - RF or LF response
THOP	17.1 ms	19 ms	20.9 ms	Delay to hopping code response - RF or LF response
TDAMP	1.08 LFTE	1.2 LFTE	1.32 LFTE	Delay from detecting LC rising edge to first damp pulse
TDEMOD	14.76 ms	16.4 ms	18 ms	Demodulator mode window looking for edge on LC pin
Timing Element T_E				
T _E	90 180 360 720	100 200 400 800	110 220 440 880	RFTE or LFTE RFBSL = LFBSL = 00 ₂ RFBSL = LFBSL = 01 ₂ RFBSL = LFBSL = 10 ₂ RFBSL = LFBSL = 11 ₂
Analog delays				
TFILTR	—	15 μs	—	HCS473 analog LF filter charge time
TFILTF	—	70 μs	—	HCS473 analog LF filter discharge time
TANTR	<i>Hardware design dependent</i>			Cumulative LF antenna delay when field is turned on
TANTF	<i>Hardware design dependent</i>			Cumulative LF antenna delay when field is turned off

- Note**
- 1: F_{osc} = 4 MHz. F_{osc} = 4 MHz may be centered at the designer's choice of supply voltage (V_{DD}) and temperature.
 - 2: LFTE is based on the HCS473's timing, not the timing of the transponder reader. Therefore LFTE is subject to HCS473 oscillator variation.
 - 3: Response timing accounts for TFILTR but not for TANTR or TANTF, as they are design dependent. The system designer must compensate communication accordingly for TANTR and TANTF.
 - 4: Timing parameters are characterized but not tested.

HCS473

TABLE 7-5: AC CHARACTERISTICS, Industrial Temperature Devices⁽⁴⁾

AC Characteristics			Tamb = -20°C to 85°C, 2.05V < VDD ≤ 3.5V unless stated otherwise Fosc = 4 MHz ±10%	
Symbol	Min	Typ ⁽¹⁾	Max	Description
General HCS473 Timing				
TDB	9 ms 9 ms	10 ms 10 ms	11 ms 12 ms	Debounce Time 3.5V < VDD < 5.5V ⁽⁴⁾
TQUE	1.8s 1.8s	2s 2s	2.2s 2.4s	Que Window 3.5V < VDD < 5.5V ⁽⁴⁾
TPU	9.81 ms 9.81 ms	10.9 ms 10.9 ms	12 ms 13.08 ms	Power-up Delay Time (includes button debounce) 3.5V < VDD < 5.5V ⁽⁴⁾
TPLL	17.1 ms 17.1 ms	19 ms 19 ms	20.9 ms 22.8 ms	Encoder Mode PLL activation to first code word 3.5V < VDD < 5.5V ⁽⁴⁾
TLEDON	90 ms 90 ms	100 ms 100 ms	110 ms 120 ms	LED ON Time 3.5V < VDD < 5.5V ⁽⁴⁾
TLEDOFF	450 ms 450 ms	500 ms 500 ms	550 ms 600 ms	LED OFF Time 3.5V < VDD < 5.5V ⁽⁴⁾
Communication from Transponder Reader to HCS473				
TCMD	1.1 LFTE+100 μs 1.2 LFTE+100 μs	— —	9.18 ms 9.18 ms	3.5V < VDD < 5.5V ⁽⁴⁾
TTSCMD	1.1 LFTE+100 μs 1.2 LFTE+100 μs	— —	9.18 ms 9.18 ms	Delay from Transponder Select ACK to next command 3.5V < VDD < 5.5V ⁽⁴⁾
TFINH	100 μs	1LFTE	—	Time to leave LF on after last data bit's rising edge
Response from HCS473 to Transponder Reader				
TSF	1 ms+9 LFTE 1 ms+9 LFTE	3.5 ms+1 LFTE 3.5 ms+1 LFTE	10 ms+1.1 LFTE 10 ms+1.2 LFTE	Delay to wake-up ACK ⁽⁴⁾
TTSACK	.9 LFTE+14 μs .9 LFTE+14 μs	1 LFTE+30 μs 1 LFTE+30 μs	1.1 LFTE+49 μs 1.2 LFTE+53 μs	Delay from TID pulse rising edge to TID Acknowledge TID = 0 3.5V < VDD < 5.5V ⁽⁴⁾
	.9 LFTE-10 μs .9 LFTE-10 μs	1 LFTE 1 LFTE	1.1 LFTE+12 μs 1.2 LFTE+13.2 μs	TID > 0 3.5V < VDD < 5.5V ⁽⁴⁾
TPACK	141 μs 141 μs	179 μs 179 μs	234 μs 255 μs	Delay to Transport Code Acknowledge 3.5V < VDD < 5.5V ⁽⁴⁾
TWRT	—	4 ms	10 ms	Delay to Write Acknowledge
TAOACK	60 μs 60 μs	89 μs 89 μs	135 μs 147 μs	Delay to anticollision off Acknowledge 3.5V < VDD < 5.5V ⁽⁴⁾
TIFF	5.07 ms 5.07 ms	5.64 ms 5.64 ms	6.2 ms 6.8 ms	Delay to IFF response - RF or LF response 3.5V < VDD < 5.5V ⁽⁴⁾
TREAD	184 μs 184 μs	227 μs 227 μs	286 μs 312 μs	Delay to read response - RF or LF response 3.5V < VDD < 5.5V ⁽⁴⁾
THOP	17.1 ms 17.1 ms	19 ms 19 ms	20.9 ms 22.8 ms	Delay to hopping code response - RF or LF response 3.5V < VDD < 5.5V ⁽⁴⁾
TDAMP	1.08 LFTE 1.08 LFTE	1.2 LFTE 1.2 LFTE	1.32 LFTE 1.44 LFTE	Delay from detecting LC rising edge to first damp pulse 3.5V < VDD < 5.5V ⁽⁴⁾
TDEMOD	14.76 ms 14.76 ms	16.4 ms 16.4 ms	18 ms 19.7 ms	Demodulator mode window looking for edge on LC pin 3.5V < VDD < 5.5V ⁽⁴⁾
Timing Element Te				
TE	90 180 360 720	100 200 400 800	110 220 440 880	RFTE or LFTE RFBSL = LFBSL = 00 ₂ RFBSL = LFBSL = 01 ₂ RFBSL = LFBSL = 10 ₂ RFBSL = LFBSL = 11 ₂

Analog delays				
TFILTR	—	15 μ s	—	HCS473 analog LF filter charge time
TFILTF	—	70 μ s	—	HCS473 analog LF filter discharge time
TANTR	<i>Hardware design dependent</i>			Cumulative LF antenna delay when field is turned on
TANTF	<i>Hardware design dependent</i>			Cumulative LF antenna delay when field is turned off

- Note 1:** Fosc = 4 MHz. FOSC = 4 MHz may be centered at the designer's choice of supply voltage (VDD) and temperature.
- 2:** LFTE is based on the HCS473's timing, not the timing of the transponder reader. Therefore LFTE is subject to HCS473 oscillator variation.
- 3:** Response timing accounts for TFILTR but not for TANTR or TANTF, as they are design dependent. The system designer must compensate communication accordingly for TANTR and TANTF.
- 4:** Min and Max values modified for FOSC = 4 MHz + 10%, -20%. Timing parameters are characterized but not tested. Very Important: Refer to Section 3.2.7 for communication requirements when using an Industrial temperature device at 3.5V < VDD < 5.5V.

HCS473

NOTES:

8.0 PACKAGING INFORMATION

8.1 Package Marking Information

14-Lead PDIP (300 mil)



Example



14-Lead SOIC (150 mil)

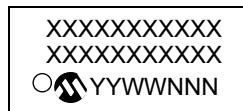

Example

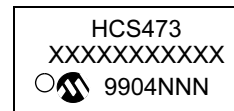

Legend: XX...X Customer specific information*
 YY Year code (last 2 digits of calendar year)
 WW Week code (week of January 1 is week '01')
 NNN Alphanumeric traceability code

Note: In the event the full Microchip part number cannot be marked on one line, it will be carried over to the next line thus limiting the number of available characters for customer specific information.

- * Standard marking consists of Microchip part number, year code, week code, facility code, mask rev#, and assembly code. For marking beyond this, certain price adders apply. Please check with your Microchip Sales Office. For SQTP devices, any special marking adders are included in SQTP price.

HCS473

14-Lead Plastic Dual In-line (P) – 300 mil (PDIP)

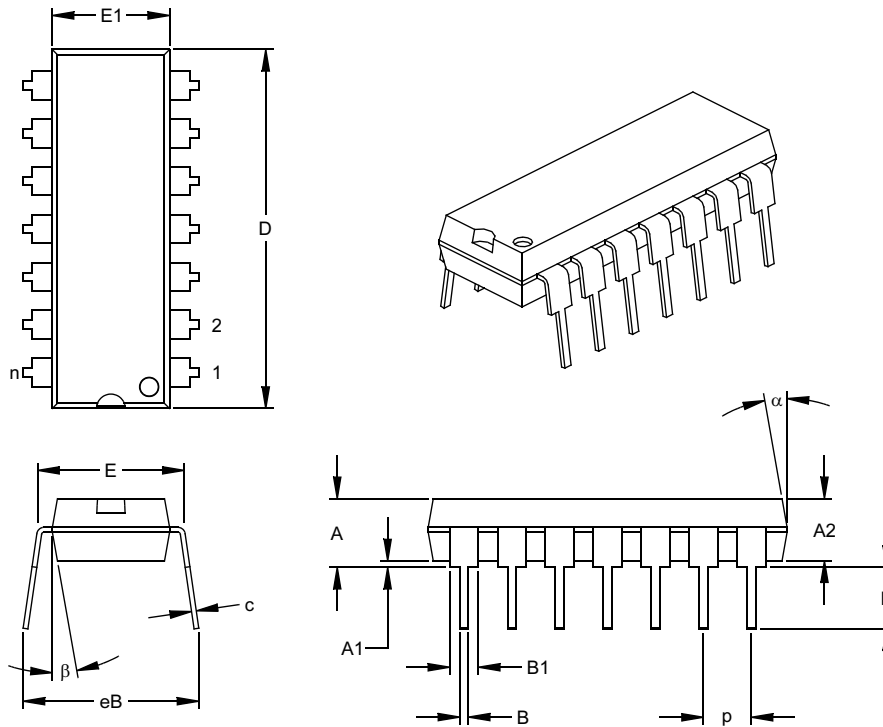

Dimension Limits	Units	INCHES*			MILLIMETERS		
		MIN	NOM	MAX	MIN	NOM	MAX
Number of Pins	n		14			14	
Pitch	p		.100			2.54	
Top to Seating Plane	A	.140	.155	.170	3.56	3.94	4.32
Molded Package Thickness	A2	.115	.130	.145	2.92	3.30	3.68
Base to Seating Plane	A1	.015			0.38		
Shoulder to Shoulder Width	E	.300	.313	.325	7.62	7.94	8.26
Molded Package Width	E1	.240	.250	.260	6.10	6.35	6.60
Overall Length	D	.740	.750	.760	18.80	19.05	19.30
Tip to Seating Plane	L	.125	.130	.135	3.18	3.30	3.43
Lead Thickness	c	.008	.012	.015	0.20	0.29	0.38
Upper Lead Width	B1	.045	.058	.070	1.14	1.46	1.78
Lower Lead Width	B	.014	.018	.022	0.36	0.46	0.56
Overall Row Spacing	§ eB	.310	.370	.430	7.87	9.40	10.92
Mold Draft Angle Top	α	5	10	15	5	10	15
Mold Draft Angle Bottom	β	5	10	15	5	10	15

* Controlling Parameter

§ Significant Characteristic

Notes:

Dimensions D and E1 do not include mold flash or protrusions. Mold flash or protrusions shall not exceed .010" (0.254 mm) per side.

JEDEC Equivalent: MS-001

Drawing No. C04-005

14-Lead Plastic Small Outline (SL) – Narrow, 150 mil (SOIC)

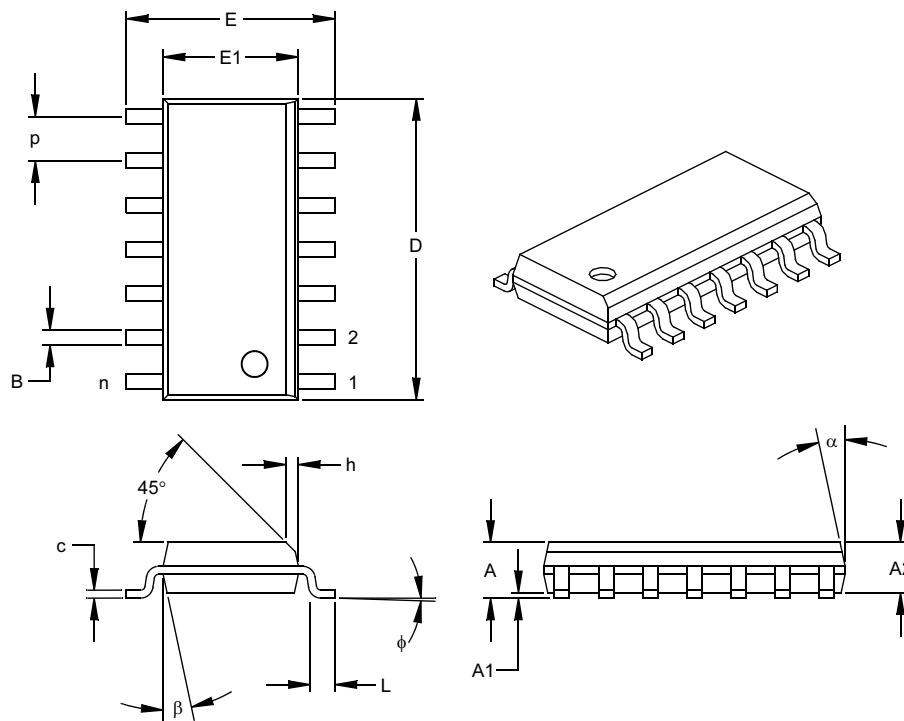

Dimension Limits	Units	INCHES*			MILLIMETERS		
	n	MIN	NOM	MAX	MIN	NOM	MAX
Number of Pins	n		14			14	
Pitch	p		.050			1.27	
Overall Height	A	.053	.061	.069	1.35	1.55	1.75
Molded Package Thickness	A2	.052	.056	.061	1.32	1.42	1.55
Standoff§	A1	.004	.007	.010	0.10	0.18	0.25
Overall Width	E	.228	.236	.244	5.79	5.99	6.20
Molded Package Width	E1	.150	.154	.157	3.81	3.90	3.99
Overall Length	D	.337	.342	.347	8.56	8.69	8.81
Chamfer Distance	h	.010	.015	.020	0.25	0.38	0.51
Foot Length	L	.016	.033	.050	0.41	0.84	1.27
Foot Angle	φ	0	4	8	0	4	8
Lead Thickness	c	.008	.009	.010	0.20	0.23	0.25
Lead Width	B	.014	.017	.020	0.36	0.42	0.51
Mold Draft Angle Top	α	0	12	15	0	12	15
Mold Draft Angle Bottom	β	0	12	15	0	12	15

* Controlling Parameter

§ Significant Characteristic

Notes:

Dimensions D and E1 do not include mold flash or protrusions. Mold flash or protrusions shall not exceed .010" (0.254 mm) per side.

JEDEC Equivalent: MS-012

Drawing No. C04-065

HCS473

NOTES:

INDEX

A

AC Characteristics	52
Anti-Collision Off	30
Assembler	
MPASM Assembler	43

C

CODE HOPPING COMMAND ('110')	29
Code Hopping Modulation Format	13
Configuration Summary	35
Consecutive Command Considerations	30
Counter Overflow Bits (OVR1, OVR0)	18
Cycle Redundancy Check (CRC)	18

D

DATA	6
DC Characteristics	50
Development Support	43
Device Description	5
Device Operation	11
Discrimination Value (DISC)	18

E

Electrical Characteristics	
Absolute Maximum Ratings	49
Encoder Activation	11
Encoder Interface	7
Encoder Mode Options	14
Encoder Operation	1
Encoder Security	1
Errata	2

G

General Description	3
---------------------------	---

H

HCS473 Hopping Code	4
HCS473 Security	4
HCS473 Transponder Start Sequence	22

I

ICEPIC In-Circuit Emulator	44
IFF Challenge and Response	26
Integrating the HCS473 Into A System	39
Internal RC Oscillator	9

K

KEELOQ Evaluation and Programming Tools	46
Key Terms	3

L

lccom	7
LED	7
LED Operation	17
LF Communication Analog Delays	30
LF Response Considerations	30
Low Voltage Detector	9
Low-End System Security Risks	4

M

MPLAB C17 and MPLAB C18 C Compilers	43
MPLAB ICD In-Circuit Debugger	45

MPLAB ICE High Performance Universal In-Circuit Emulator with MPLAB IDE	44
MPLAB Integrated Development Environment Software	43
MPLINK Object Linker/MPLIB Object Librarian	44

P

Packaging Information	57
Peripherals	1
PICDEM 1 Low Cost PICmicro Demonstration Board	45
PICDEM 17 Demonstration Board	46
PICDEM 2 Low Cost PIC16CXX Demonstration Board	45
PICDEM 3 Low Cost PIC16CXXX Demonstration Board	46
PICSTART Plus Entry Level Development Programmer	45
Present Transport Code	25
PRO MATE II Universal Device Programmer	45
Product Identification System	64
Programming Specification	37

R

Read Sequence	27
Receive Stability - Calculating Communication	32
Request Hopping Code Command	29
RFEN During LF Communication	33

S

S0	6
s3	6
Select Transponder	24
Software Simulator (MPLAB SIM)	44

T

Transmitted Code Word	11
Transponder Characteristics	51
Transponder Commands	23
Transponder Communication	21
Transponder Interface	8
Transponder Mode	18
Transponder Operation	1
Transponder Options	19
Transponder Security	1
Typical Applications	1

W

Wake-Up Logic	7
WWW, On-Line Support	2

ON-LINE SUPPORT

Microchip provides on-line support on the Microchip World Wide Web site.

The web site is used by Microchip as a means to make files and information easily available to customers. To view the site, the user must have access to the Internet and a web browser, such as Netscape® or Microsoft® Internet Explorer. Files are also available for FTP download from our FTP site.

Connecting to the Microchip Internet Web Site

The Microchip web site is available at the following URL:

www.microchip.com

The file transfer site is available by using an FTP service to connect to:

<ftp://ftp.microchip.com>

The web site and file transfer site provide a variety of services. Users may download files for the latest Development Tools, Data Sheets, Application Notes, User's Guides, Articles and Sample Programs. A variety of Microchip specific business information is also available, including listings of Microchip sales offices, distributors and factory representatives. Other data available for consideration is:

- Latest Microchip Press Releases
- Technical Support Section with Frequently Asked Questions
- Design Tips
- Device Errata
- Job Postings
- Microchip Consultant Program Member Listing
- Links to other useful web sites related to Microchip Products
- Conferences for products, Development Systems, technical information and more
- Listing of seminars and events

SYSTEMS INFORMATION AND UPGRADE HOT LINE

The Systems Information and Upgrade Line provides system users a listing of the latest versions of all of Microchip's development systems software products. Plus, this line provides information on how customers can receive the most current upgrade kits. The Hot Line Numbers are:

1-800-755-2345 for U.S. and most of Canada, and

1-480-792-7302 for the rest of the world.

092002

READER RESPONSE

It is our intention to provide you with the best documentation possible to ensure successful use of your Microchip product. If you wish to provide your comments on organization, clarity, subject matter, and ways in which our documentation can better serve you, please FAX your comments to the Technical Publications Manager at (480) 792-4150.

Please list the following information, and use this outline to provide us with your comments about this document.

To: Technical Publications Manager
RE: Reader Response
From: Name _____
Company _____
Address _____
City / State / ZIP / Country _____
Telephone: (_____) _____ - _____ FAX: (_____) _____ - _____

Application (optional):

Would you like a reply? ___Y ___N

Device: HCS473

Literature Number: DS40035C

Questions:

1. What are the best features of this document?

2. How does this document meet your hardware and software development needs?

3. Do you find the organization of this document easy to follow? If not, why?

4. What additions to the document do you think would enhance the structure and subject?

5. What deletions from the document could be made without affecting the overall usefulness?

6. Is there any incorrect or misleading information (what and where)?

7. How would you improve this document?

HCS473

PRODUCT IDENTIFICATION SYSTEM

To order or obtain information, e.g., on pricing or delivery, refer to the factory or the listed sales office.

<u>PART NO.</u>	X	XX	XXX
Device	Temperature Range	Package	Pattern
Device	HCS473		
Temperature Range	- = 0°C to +70°C I = -20°C to +85°C		
Package	P = PDIP SL = SOIC		
Pattern	QTP, SQTP, ROM Code (factory specified) or Special Requirements . Blank for OTP and Windowed devices.		

Examples:
a) To be supplied.

* JW Devices are UV erasable and can be programmed to any device configuration. JW Devices meet the electrical requirement of each oscillator type.

Sales and Support

Data Sheets

Products supported by a preliminary Data Sheet may have an errata sheet describing minor operational differences and recommended workarounds. To determine if an errata sheet exists for a particular device, please contact one of the following:

1. Your local Microchip sales office
2. The Microchip Corporate Literature Center U.S. FAX: (480) 792-7277
3. The Microchip Worldwide Site (www.microchip.com)

Please specify which device, revision of silicon and Data Sheet (include Literature #) you are using.

New Customer Notification System

Register on our web site (www.microchip.com/cn) to receive the most current information on our products.

NOTES:



MICROCHIP

WORLDWIDE SALES AND SERVICE

AMERICAS

Corporate Office

2355 West Chandler Blvd.
Chandler, AZ 85224-6199
Tel: 480-792-7200 Fax: 480-792-7277
Technical Support: 480-792-7627
Web Address: <http://www.microchip.com>

Rocky Mountain

2355 West Chandler Blvd.
Chandler, AZ 85224-6199
Tel: 480-792-7966 Fax: 480-792-4338

Atlanta

500 Sugar Mill Road, Suite 200B
Atlanta, GA 30350
Tel: 770-640-0034 Fax: 770-640-0307

Boston

2 Lan Drive, Suite 120
Westford, MA 01886
Tel: 978-692-3848 Fax: 978-692-3821

Chicago

333 Pierce Road, Suite 180
Itasca, IL 60143
Tel: 630-285-0071 Fax: 630-285-0075

Dallas

4570 Westgrove Drive, Suite 160
Addison, TX 75001
Tel: 972-818-7423 Fax: 972-818-2924

Detroit

Tri-Atria Office Building
32255 Northwestern Highway, Suite 190
Farmington Hills, MI 48334
Tel: 248-538-2250 Fax: 248-538-2260

Kokomo

2767 S. Albright Road
Kokomo, Indiana 46902
Tel: 765-864-8360 Fax: 765-864-8387

Los Angeles

18201 Von Karman, Suite 1090
Irvine, CA 92612
Tel: 949-263-1888 Fax: 949-263-1338

San Jose

Microchip Technology Inc.
2107 North First Street, Suite 590
San Jose, CA 95131
Tel: 408-436-7950 Fax: 408-436-7955

Toronto

6285 Northam Drive, Suite 108
Mississauga, Ontario L4V 1X5, Canada
Tel: 905-673-0699 Fax: 905-673-6509

ASIA/PACIFIC

Australia

Microchip Technology Australia Pty Ltd
Suite 22, 41 Rawson Street
Epping 2121, NSW
Australia
Tel: 61-2-9868-6733 Fax: 61-2-9868-6755

China - Beijing

Microchip Technology Consulting (Shanghai)
Co., Ltd., Beijing Liaison Office
Unit 915
Bei Hai Wan Tai Bldg.
No. 6 Chaoyangmen Beidajie
Beijing, 100027, No. China
Tel: 86-10-85282100 Fax: 86-10-85282104

China - Chengdu

Microchip Technology Consulting (Shanghai)
Co., Ltd., Chengdu Liaison Office
Rm. 2401, 24th Floor,
Ming Xing Financial Tower
No. 88 TIDU Street
Chengdu 610016, China
Tel: 86-28-86766200 Fax: 86-28-86766599

China - Fuzhou

Microchip Technology Consulting (Shanghai)
Co., Ltd., Fuzhou Liaison Office
Unit 28F, World Trade Plaza
No. 71 Wusi Road
Fuzhou 350001, China
Tel: 86-591-7503506 Fax: 86-591-7503521

China - Shanghai

Microchip Technology Consulting (Shanghai)
Co., Ltd.
Room 701, Bldg. B
Far East International Plaza
No. 317 Xian Xia Road
Shanghai, 200051
Tel: 86-21-6275-5700 Fax: 86-21-6275-5060

China - Shenzhen

Microchip Technology Consulting (Shanghai)
Co., Ltd., Shenzhen Liaison Office
Rm. 1315, 13/F, Shenzhen Kerry Centre,
Renminnan Lu
Shenzhen 518001, China
Tel: 86-755-82350361 Fax: 86-755-82366086

China - Hong Kong SAR

Microchip Technology Hongkong Ltd.
Unit 901-6, Tower 2, Metroplaza
223 Hing Fong Road
Kwai Fong, N.T., Hong Kong
Tel: 852-2401-1200 Fax: 852-2401-3431

India

Microchip Technology Inc.
India Liaison Office
Divyasree Chambers
1 Floor, Wing A (A3/A4)
No. 11, O'Shaugnessey Road
Bangalore, 560 025, India
Tel: 91-80-2290061 Fax: 91-80-2290062

Japan

Microchip Technology Japan K.K.
Benex S-1 6F
3-18-20, Shinyokohama
Kohoku-Ku, Yokohama-shi
Kanagawa, 222-0033, Japan
Tel: 81-45-471- 6166 Fax: 81-45-471-6122

Korea

Microchip Technology Korea
168-1, Youngbo Bldg. 3 Floor
Samsung-Dong, Kangnam-Ku
Seoul, Korea 135-882
Tel: 82-2-554-7200 Fax: 82-2-558-5934

Singapore

Microchip Technology Singapore Pte Ltd.
200 Middle Road
#07-02 Prime Centre
Singapore, 188980
Tel: 65-6334-8870 Fax: 65-6334-8850

Taiwan

Microchip Technology (Barbados) Inc.,
Taiwan Branch
11F-3, No. 207
Tung Hua North Road
Taipei, 105, Taiwan
Tel: 886-2-2717-7175 Fax: 886-2-2545-0139

EUROPE

Austria

Microchip Technology Austria GmbH
Durisolstrasse 2
A-4600 Wels
Austria
Tel: 43-7242-2244-399
Fax: 43-7242-2244-393

Denmark

Microchip Technology Nordic ApS
Regus Business Centre
Lautrup hoj 1-3
Ballerup DK-2750 Denmark
Tel: 45 4420 9895 Fax: 45 4420 9910

France

Microchip Technology SARL
Parc d'Activite du Moulin de Massy
43 Rue du Saule Trapu
Batiment A - 1er Etage
91300 Massy, France
Tel: 33-1-69-53-63-20 Fax: 33-1-69-30-90-79

Germany

Microchip Technology GmbH
Steinheilstrasse 10
D-85737 Ismaning, Germany
Tel: 49-89-627-144 0 Fax: 49-89-627-144-44

Italy

Microchip Technology SRL
Centro Direzionale Colleoni
Palazzo Taurus 1 V. Le Colleoni 1
20041 Agrate Brianza
Milan, Italy
Tel: 39-039-65791-1 Fax: 39-039-6899883

United Kingdom

Microchip Ltd.
505 Eskdale Road
Winnersh Triangle
Wokingham
Berkshire, England RG41 5TU
Tel: 44 118 921 5869 Fax: 44-118 921-5820

10/18/02