



SPEAKER ELEVATION AUDIO PROCESSOR with A/V Focus Filter

■ GENERAL DESCRIPTION

The **NJM2189** is a speaker elevation audio processor with A/V Focus Filter, based on SRS Focus technology. It is capable of raising sound image.

In addition, the **NJM2189** includes the A/V Focus Filter to reduce harsh sound when speakers are directly put on hard-surface floor.

The Bypass and Focus Mode inputs are separate to be the same sound volume in both Bypass and Focus mode.

The **NJM2189** is suitable for almost all car audio, Projection TV, radio cassette, and then.

■ PACKAGE OUTLINE

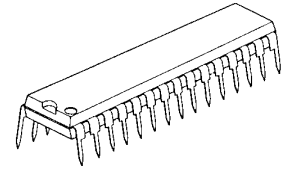

NJM2189L

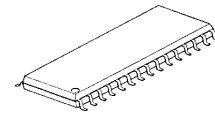

NJM2189M

■ FEATURES

- Operating Voltage (4.7 to 13V)
- Low Operating Current (7.0mA typ.)
- Low Output Noise (15 μ Vrms typ.)
- Adjusted by LF/HF Elevation, and Bass Compensation Volume
- Internal A/V Focus Filter
- Independent Audio Input for Bypass Mode
- Bipolar Technology
- Package Outline SDIP30, SDMP30

The FOCUS technology rights incorporated in the NJM2189 are owned by SRS Labs, a U.S. Corporation and licensed to New Japan Radio Co., Ltd. FOCUS are protected under U.S. and foreign patents issued and/or pending. FOCUS and the  are trademarks of SRS Labs, Inc. in the United States and selected foreign countries. Neither the purchase of the NJM2189, nor the corresponding sale of audio enhancement equipment conveys the right to sell commercialized recordings made with any SRS technology.

SRS Labs requires that all users of the NJM2189 must enter into a license agreement directly with SRS Labs if the royalty is not included in the purchase price. SRS Labs also requires any users to comply with all rules and regulations as outlined in the SRS Trademark Usage Manual.

For further information, please contact:
 SRS Labs, Inc.
 2909 Daimler Street, Santa Ana, CA 92705 USA
 Tel:949-442-1070 Fax:949-852-1099 <http://www.srslabs.com>

■ ABSOLUTE MAXIMUM RATING (Ta=25°C)

PARAMETER	SYMBOL	RATING	UNIT
Supply Voltage	V ⁺	15	V
Power Dissipation	P _D	(SDIP30)700 (SDMP30)700	mW
Operating Temperature Range	T _{opr}	-40 to +85	°C
Storage Temperature Range	T _{stg}	-40 to +125	°C

■ ELECTRICAL CHARACTERISTICS (V₊=12V, Ta=25°C, Connect Bypass Mode input and Focus Mode input)

PARAMETER	SYMBOL	TEST CONDITION		MIN.	TYP.	MAX.	UNIT
Operating Voltage	V ⁺			4.7	12.0	13.0	V
Supply Current	I _{CC}	No Signal		-	7.0	10.5	mA
Reference Voltage	V _{REF}	V ₊ /2		5.8	6.0	6.2	V
Maximum Input Voltage	V _{INMAX}	f=1kHz at T.H.D.=3%	Bypass Mode	7.79 (2.45)	11.8 (3.88)	-	dBV (V _{rms})
			Focus Mode	-4.71 (0.58)	-1.21 (0.87)	-	
			A/V Focus Mode	-5.21 (0.55)	-1.71 (0.82)	-	
		f=70Hz at T.H.D.=3% Controls ∞	Bypass Mode	-	11.8 (3.88)	-	
			Focus Mode	-	0.77 (1.1)	-	
			A/V Focus Mode	-	0.77 (1.1)	-	
		f=10kHz at T.H.D.=3% Controls ∞	Bypass Mode	-	11.8 (3.88)	-	
			Focus Mode	-	-8.71 (0.37)	-	
			A/V Focus Mode	-	-8.71 (0.37)	-	
Output Noise	V _{NOISE}	Vin=V _{REF} A-weight Controls ∞	Focus Mode	-	-94.0 (20.0)	-88.0 (40.0)	dBV (μV _{rms})
			A/V Focus Mode	-	-94.0 (20.0)	-88.0 (40.0)	
		Vin=V _{REF} A-weight Controls Center	Focus Mode	-	-96.5 (15.0)	-	
			A/V Focus Mode	-	-96.5 (15.0)	-	
		Vin=V _{REF} A-weight Controls 0	Focus Mode	-	-96.5 (15.0)	-	
			A/V Focus Mode	-	-96.5 (15.0)	-	

■ ELECTRICAL CHARACTERISTICS ($V^+ = 12V, T_a = 25^\circ C$)

PARAMETER	SYMBOL	TEST CONDITION		MIN.	TYP.	MAX.	UNIT
Output Noise	V_{NOISE}	$V_{in} = V_{REF}$ DIN-AUDIO Controls ∞	Focus Mode	-	-90.1 (30.0)	-	dBV (μV_{rms})
			A/V Focus Mode	-	-90.1 (30.0)	-	
		$V_{in} = V_{REF}$ DIN-AUDIO Controls Center	Focus Mode	-	-94.0 (20.0)	-	
			A/V Focus Mode	-	-94.0 (20.0)	-	
		$V_{in} = V_{REF}$ DIN-AUDIO Controls 0	Focus Mode	-	-94.0 (20.0)	-	
			A/V Focus Mode	-	-96.5 (15.0)	-	
Channel Balance	CH_{BAL}	$V_{in} = -17.2dBV$ $f = 1kHz$ Controls ∞	Focus Mode	-1.0	0.0	1.0	dB
			A/V Focus Mode	-1.0	0.0	1.0	
Total Harmonic Distortion	THD	$V_{in} = -17.2dBV$ Lch $f = 1kHz$ Controls ∞	Focus Mode	-	0.05	0.20	%
			A/V Focus Mode	-	0.09	0.30	
BYPASS Gain	G_{BYP}	$V_{in} = -17.2dBV$ $f = 1kHz$	Bypass Mode	-1.0	0.0	1.0	dB
FOCUS Gain1	G_{FOC1}	$V_{in} = -17.2dBV$ $f = 70Hz$ Controls ∞	Focus Mode	8.5	10.5	12.5	dB
FOCUS Gain2	G_{FOC2}	$V_{in} = -17.2dBV$ $f = 20kHz$ Controls ∞	Focus Mode	19.0	21.0	23.0	dB
AVF Gain	G_{AVF}	$V_{in} = -17.2dBV$ $f = 800Hz$ Controls 0	A/V Focus Mode	-12.0	-10.0	-8.0	dB
MODE Select Control Voltage	V_{MODE}	$V_{in} = \text{High Level}$		2.0	-	V^+	V
		$V_{in} = \text{Low Level}$		0.0	-	0.7	

■ MODE SWITCH

	MODE1	MODE2
Bypass Mode	L	-
Focus Mode	H	L
A/V Focus Mode	H	H

■ PIN FUNCTION

Bypass Mode Lch Input	1	Lin1	Rin1	30	Bypass Mode Rch Input
FOCUS Mode Lch Input	2	Lin2	Rin2	29	FOCUS Mode Rch Input
Lch LF Elevation Control Output	3	LFoutL	LFoutR	28	Rch LF Elevation Control Output
Lch LF Elevation Control Input	4	LFinL	LFinR	27	Rch LF Elevation Control Input
Lch HF Elevation Control Input 1	5	HFinL1	HFinR1	26	Rch HF Elevation Control Input 1
Lch HF Elevation Control Input 2	6	HFinL2	HFinR2	25	Rch HF Elevation Control Input 2
Bass Compensation Control Output	7	BCout	LPFout	24	LPF Output
Bass Compensation Control Input	8	BCin	LPFin	23	LPF Input
Lch Focus Output	9	FoutL	FoutR	22	Rch Focus Output
Lch A/V Focus filter Input	10	AVFFinL	AVFFinR	21	Rch A/V Focus filter Input
Lch A/V Focus filter Output	11	AVFFoutL	AVFFoutR	20	Rch A/V Focus filter Output
Lch Output	12	Lout	Rout	19	Rch Output
Vref Input	13	REFin	MODE1	18	Focus/Bypass Mode Select
V+/2	14	Vref	MODE2	17	A/V Focus filter ON/OFF select
Ground	15	GND	V+	16	4.7 to 13.0V Supply

■ BLOCK DIAGRAM

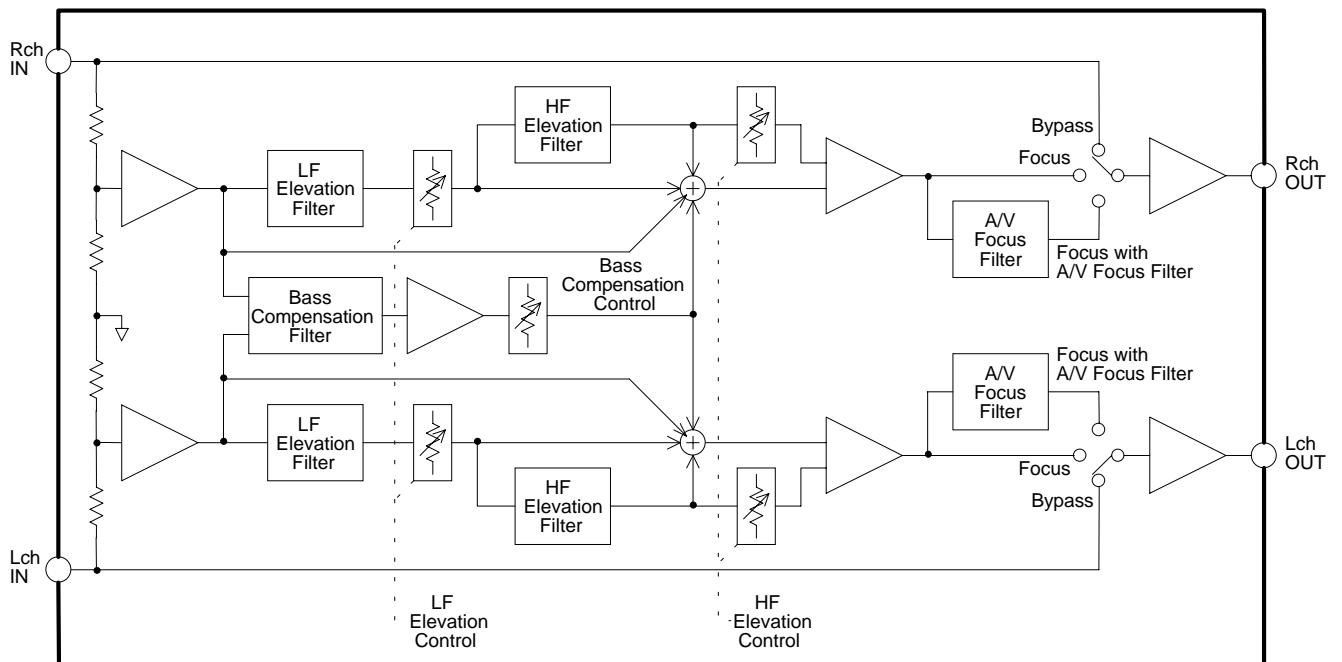

■PIN DESCRIPTION

Lin1, Rin1

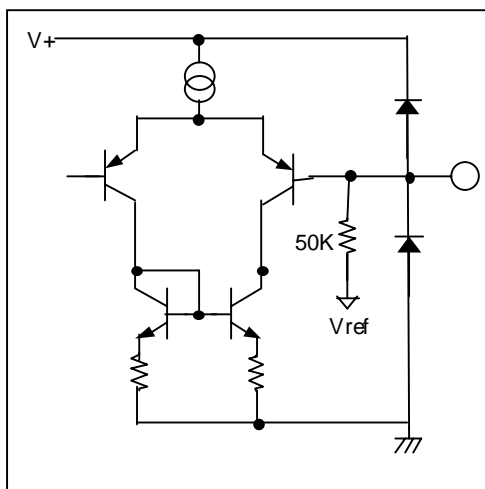

Lin2, Rin2

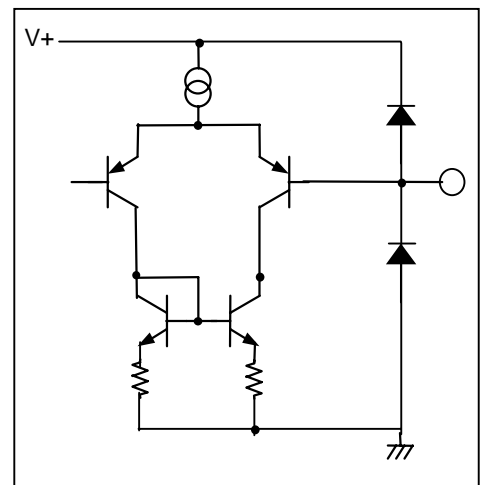

MODE1, MODE2

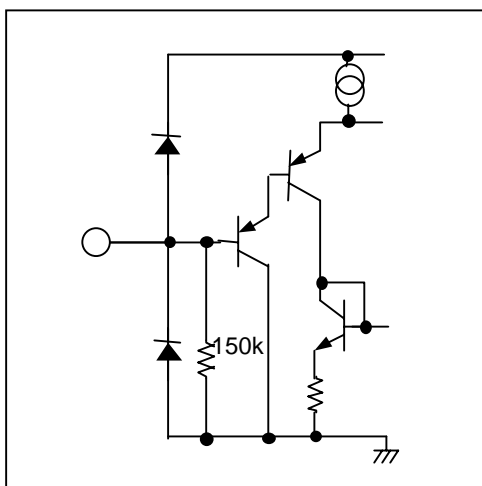

REFin

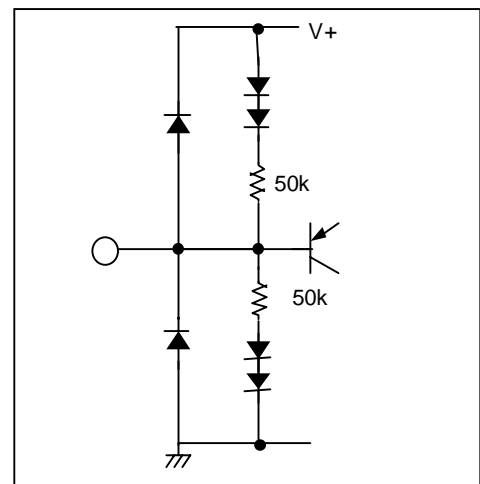

Lout,Rout,Vref

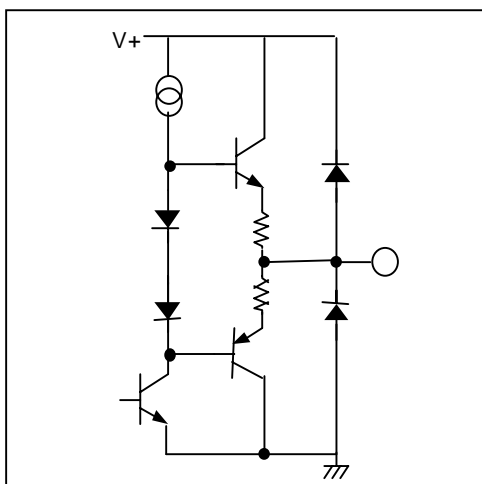

APPLICATION CIRCUIT

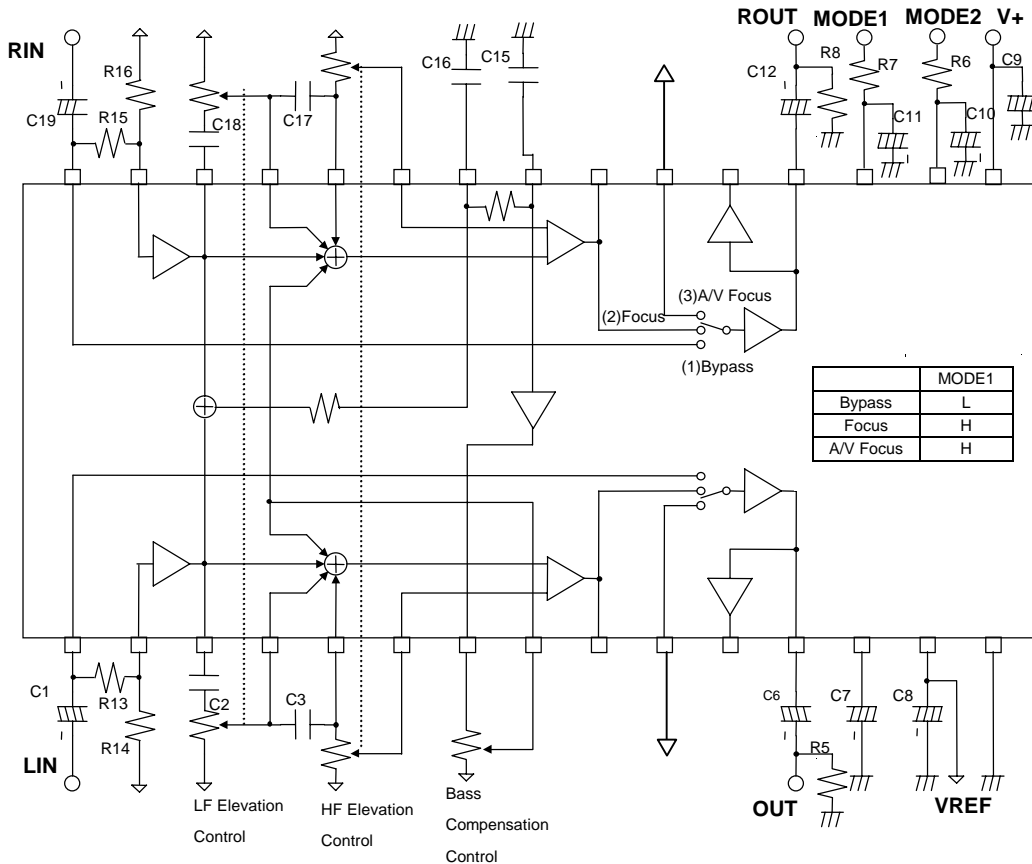

PART No.	VALUE	Tolerance	PART No.	VALUE	Tolerance
C1,C6,C7	10uF		R5,R6,R8	10kΩ	
C10,C11,C12,C19	10uF		R7	22kΩ	±5%
C8	33uF				
C9	100uF				
C2,C18	0.22uF	±5%			
C3,C17	3900uF	±5%			
C15	0.01uF	±5%			
C16	0.1uF	±5%			

- R13(R15), R14(R16)
The R13 (R15) and R14(R16) control sound pressure level when between Bypass and Focus MODE switch.
 $R13+R14 \geq 20k\Omega$
 $R13=R15, R14=R16$
- LF Elevation Control: 1kB Single-shaft Dual-unit
- HF Elevation Control: 10kB Single-shaft Dual-unit
- Bass Compensation Control: 1kB Single-shaft Single-unit

APPLICATION CIRCUIT (Without AV Focus filter)

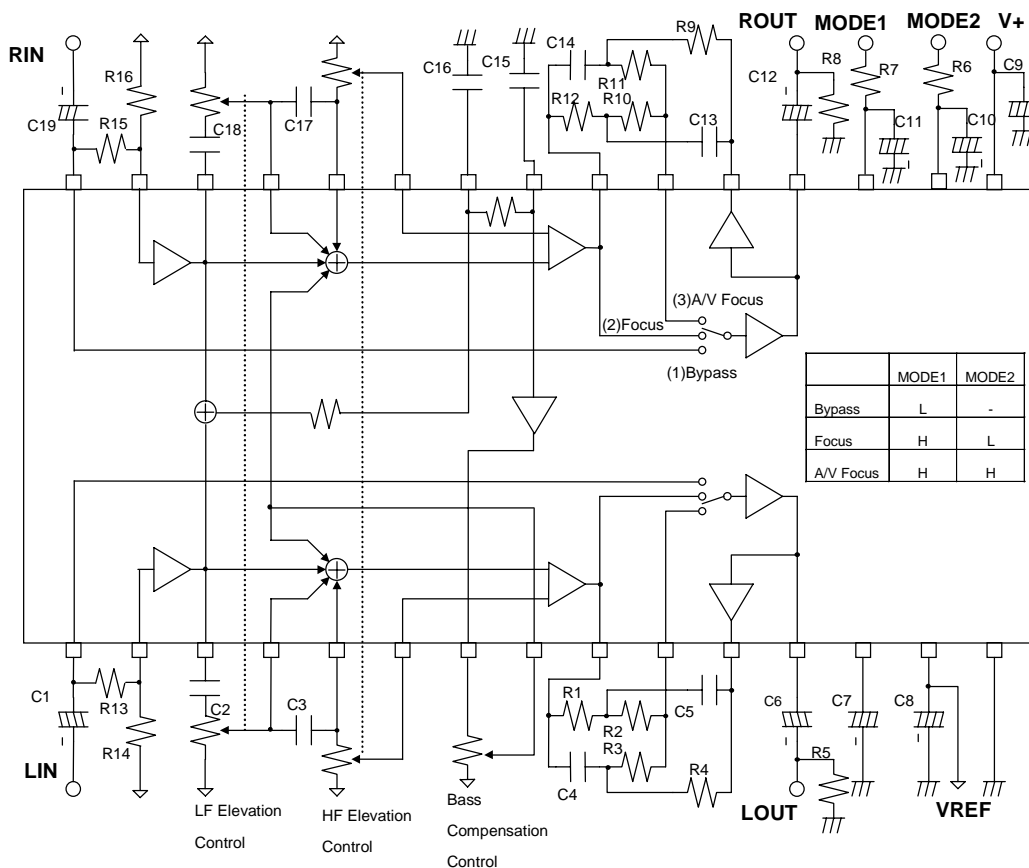

PART No.	VALUE	Tolerance	PART No.	VALUE	Tolerance
C1,C6,C7	10uF		R5,R6,R8	10kΩ	
C10,C11,C12,C19	10uF		R1,R12	1.8kΩ	±5%
C8	33uF		R2,R3,R7,R10,R11	22kΩ	±5%
C9	100uF		R4,R9	5.6kΩ	±5%
C2,C18	0.2uF	±5%			
C3,C17	3900pF	±5%			
C4,C14,C15	0.01uF	±5%			
C5,C13	0.47uF	±5%			
C16	0.1uF	±5%			

- R13(R15), R14(R16)
The R13(R15) and R14(R16) control sound pressure level when between Bypass and Focus MODE switch.
R13+R14 ≥ 20kΩ
R13=R15, R14=R16
- LF Elevation Control: 1kB Single-shaft Dual-unit
- HF Elevation Control: 10kB Single-shaft Dual-unit
- Bass Compensation Control: 1kB Single-shaft Single-unit

CHARACTERISTICS

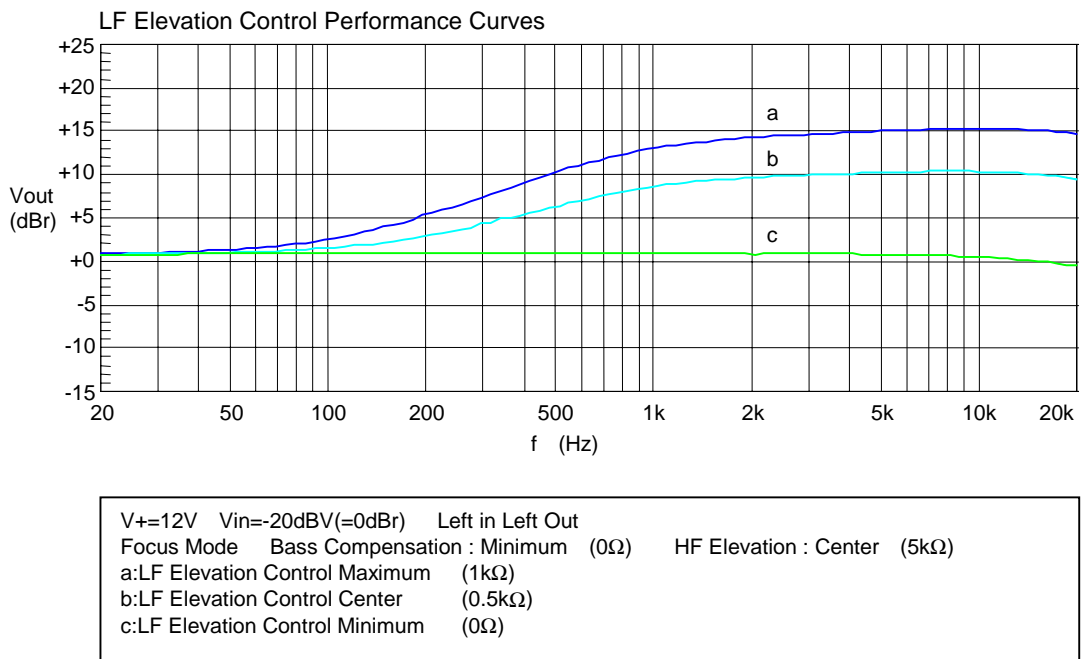
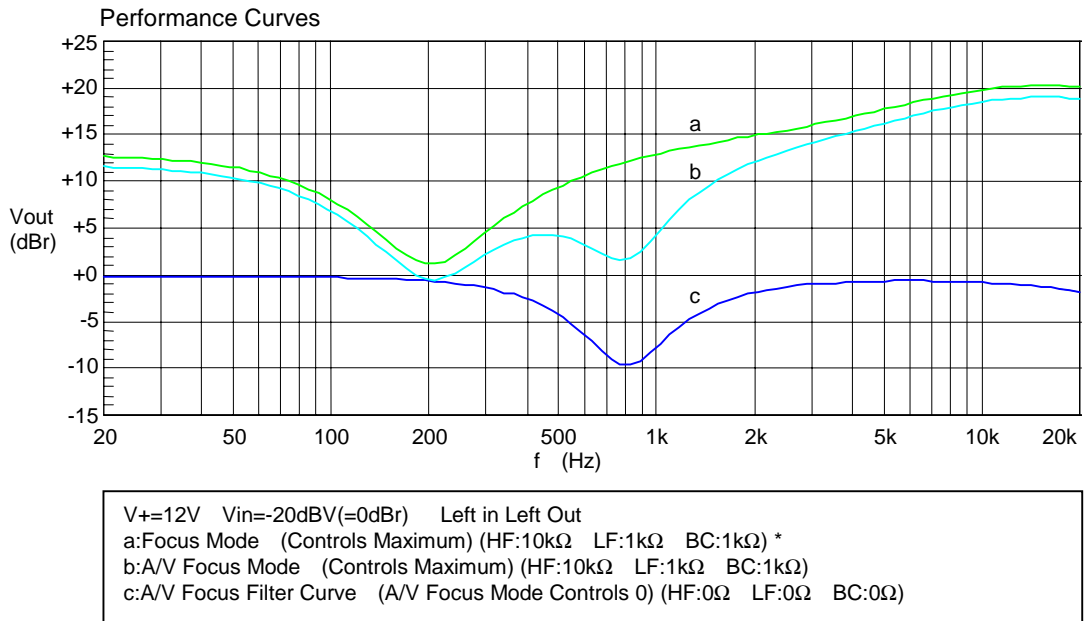

* HF:HF Elevation
 LF:LF Elevation
 BC:Bass Compensation

CHARACTERISTICS

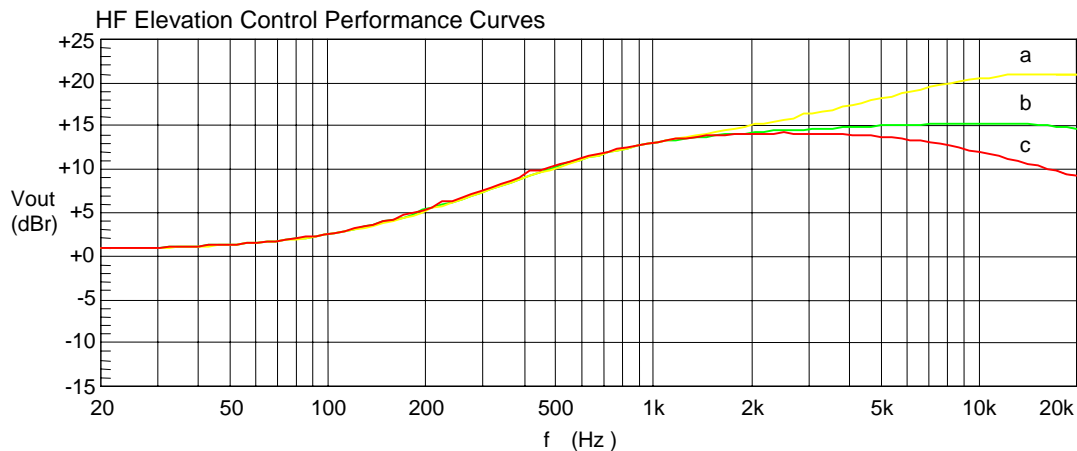

$V_{+}=12V$ $V_{in}=-20dBV(=0dBr)$ Left in Left Out
 Focus Mode bass Compensation : Minimum (0Ω) LF Elevation : Maximum ($1k\Omega$)
 a:HF Elevation Control Maximum ($10k\Omega$)
 b:HF Elevation Control Center ($5k\Omega$)
 c:HF Elevation Control Minimum (0Ω)

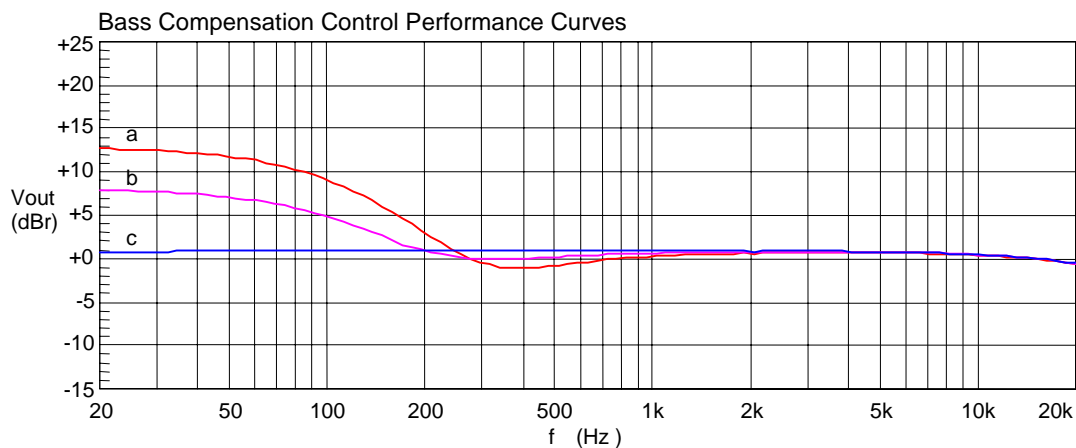

$V_{+}=12V$ $V_{in}=-20dBV(=0dBr)$ Left in Left Out
 Focus Mode LF Elevation : Minimum (0Ω)
 a:Bass Compensation Control Maximum ($1k\Omega$)
 b:Bass Compensation Control Center ($0.5k\Omega$)
 c:Bass Compensation Control Minimum (0Ω)

CHARACTERISTIC

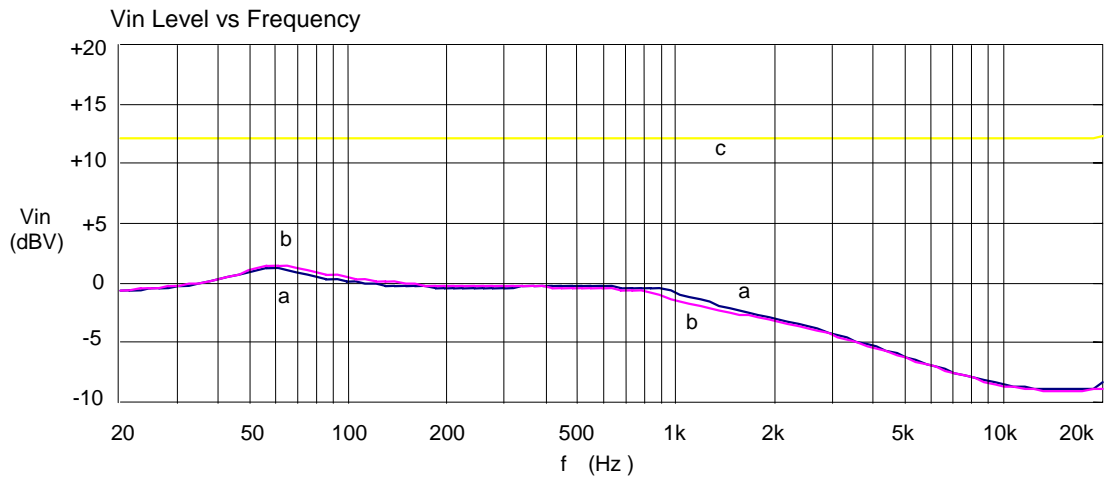

V+=12V , THD=3%
 a:Focus Mode (Controls Maximum) (HF:10kΩ LF:1kΩ BC:1kΩ)
 b:A/V Focus Mode (Controls Maximum) (HF:10kΩ LF:1kΩ BC:1kΩ)
 c:Bypass Mode

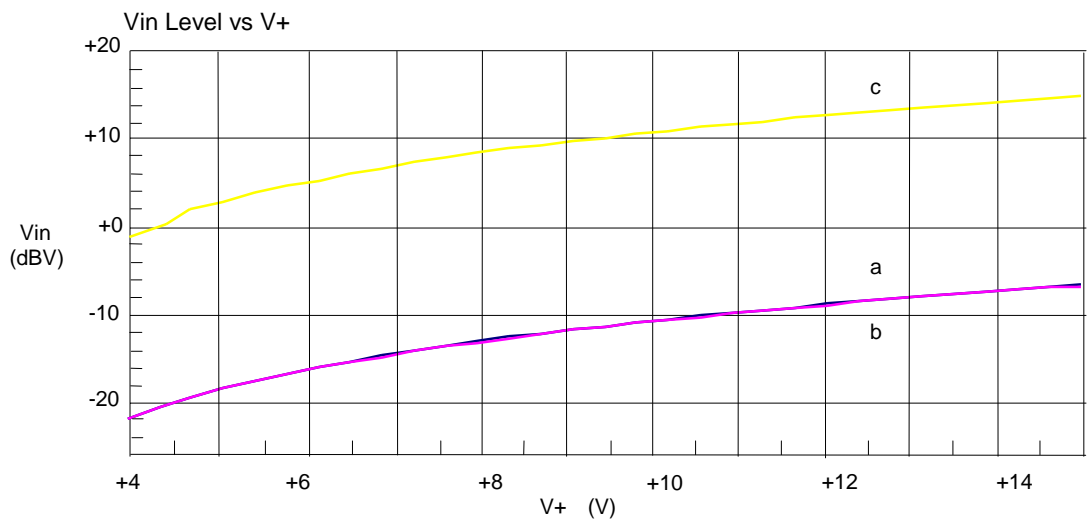

f=20kHz , fin=20kHz , THD=3%
 a:Focus Mode (Controls Maximum) (HF:10kΩ LF:1kΩ BC:1kΩ)
 b:A/V Focus Mode (Controls Maximum) (HF:10kΩ LF:1kΩ BC:1kΩ)
 c:Bypass Mode

[CAUTION]
 The specifications on this databook are only given for information , without any guarantee as regards either mistakes or omissions. The application circuits in this databook are described only to show representative usages of the product and not intended for the guarantee or permission of any right including the industrial rights.