

Surface Mount Rectifiers

RS2AA--RS2MA

FEATURES

- Low profile package
- For surface mounted applications
- Built-in strain relief, ideal for automated placement
- Plastic package has underwriters, laborator flammability classification 94V-0
- High temperature soldering: 250°C/10 seconds at terminals



Lead-free



MECHANICAL DATA

- Case :JEDEC SMA, molded plastic over passivated chip
- Terminals: Solder plated, solderable per MIL-STD-750, Method 2026
- Polarity: color band denotes cathode end
- Weight: 0.002 ounces, 0.064 gram

Maximum Ratings (@TA = 25°C unless otherwise specified)

Characteristic	Symbol	RS2AA	RS2BA	RS2DA	RS2GA	RS2JA	RS2KA	RS2MA	UNITS
Maximum recurrent peak reverse voltage	V_{RRM}	50	100	200	400	600	800	1000	V
Maximum RMS voltage	V_{RMS}	35	70	140	280	420	560	700	V
Maximum DC blocking voltage	V_{DC}	50	100	200	400	600	800	1000	V
Maximum average forward rectified current $T_L=90^\circ\text{C}$	$I_{F(AV)}$	2.0							A
Peak forward surge current @ $T_L = 110^\circ\text{C}$ 8.3ms single half-sine-wave superimposed on rated load	I_{FSM}	50							A

Thermal Characteristics

Characteristic	Symbol	RS2AA	RS2BA	RS2DA	RS2GA	RS2JA	RS2KA	RS2MA	UNITS
Typical junction capacitance (Note2)	C_J	18							p F
Typical thermal resistance (Note3)	$R_{\theta JA}$	40							°C/W
	$R_{\theta JL}$	15							
Operating junction and storage temperature range	$T_J T_{STG}$	- 55 ----- + 150							°C

Electrical Characteristics (@TA = 25°C unless otherwise specified)

Characteristic	Symbol	RS2AA	RS2BA	RS2DA	RS2GA	RS2JA	RS2KA	RS2MA	UNITS
Maximum instantaneous forward voltage at 2.0 A	V_F	1.30							V
Maximum reverse current @ $T_A=25^\circ\text{C}$ at rated DC blocking voltage @ $T_A=125^\circ\text{C}$	I_R	5.0 200							μA
Typical reverse recovery time (Note1)	t_{rr}	150				250	500		ns

 NOTE: 1.Reverse recovery time test conditions: $I_F=0.5\text{A}$, $I_R=1.0\text{A}$, $I_{rr}=0.25\text{A}$

2. Measured at 1.0MHz and applied reverse voltage of 4.0 Volts

 3. Thermal resistance from junction to ambient and junction to lead P.C.B. mounted on 0.2"X0.2"(5.0X5.0mm²) copper pad areas

Surface Mount Rectifiers

RS2AA--RS2MA

PACKAGE OUTLINE DIMENSIONS

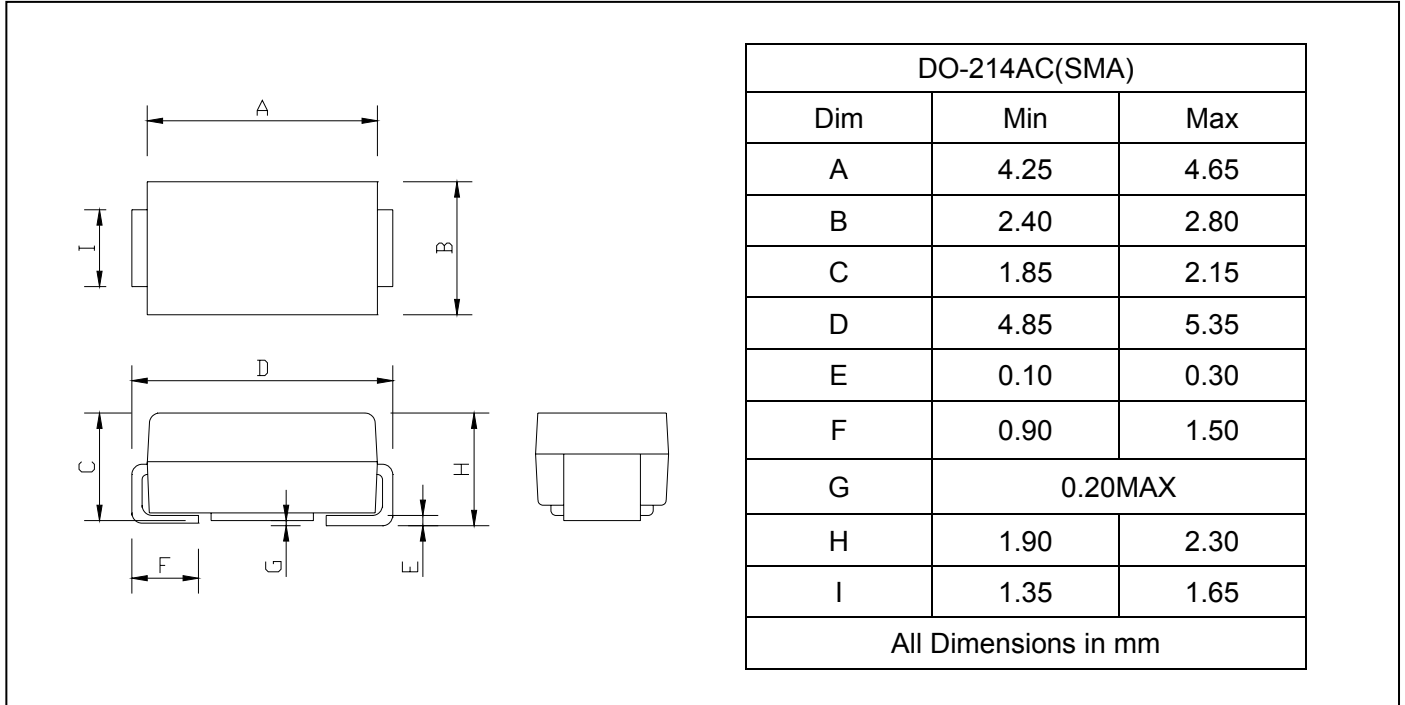

SOLDERING FOOTPRINT

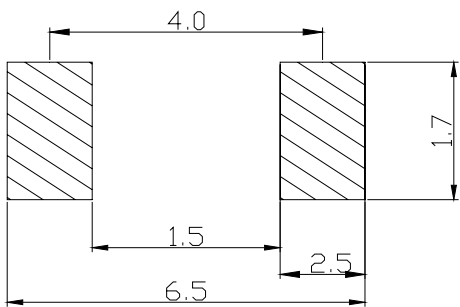

Unit : mm

PACKAGE INFORMATION

Device	Package	Shipping
RS2AA--RS2MA	DO-214AC(SMA)	5000/Tape&Reel



Surface Mount Rectifiers

RS2AA--RS2MA

FIG.1 -- FORWARD DERATING CURVE

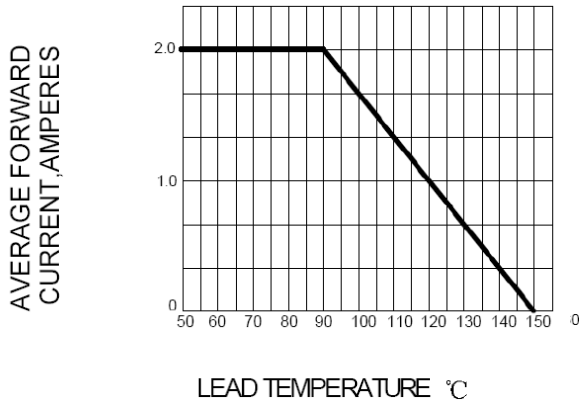

FIG.2 PEAK FORWARD SURGE CURRENT

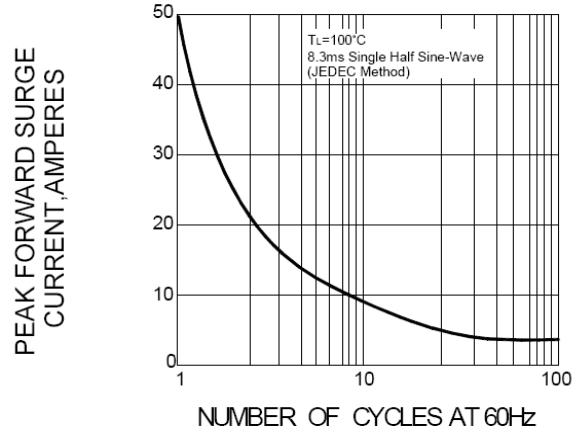

FIG.3 -- TYPICAL FORWARD CHARACTERISTICS

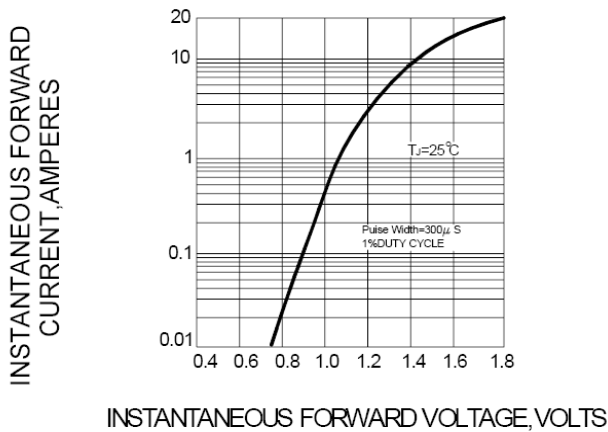

FIG.4 -- TYPICAL REVERSE CHARACTERISTICS

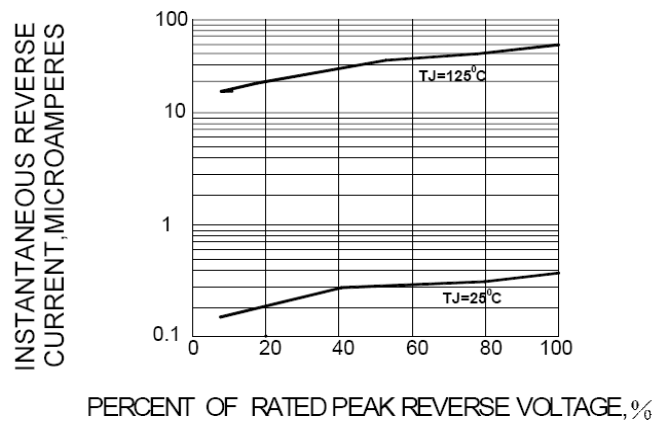

FIG.5-TYPICAL JUNCTION CAPACITANCE

